



Kawasaki

ZXR400



**Motorcycle
Service Manual
Supplement**

Quick Reference Guide

General Information	1
Fuel System	2
Cooling System	3
Engine Top End	4
Clutch	5
Engine Lubrication System	6
Engine Removal / Installation	7
Crankshaft / Transmission	8
Wheels/Tires	9
Final Drive	10
Brakes	11
Suspension	12
Steering	13
Frame	14
Electrical System	15
Appendix	16
Supplement-1999 Model	17

This quick reference guide will assist you in locating a desired topic or procedure.

- Bend the pages back to match the black tab of the desired chapter number with the black tab on the edge at each table of contents page.
- Refer to the sectional table of contents for the exact pages to locate the specific topic required.



ZXR400

Motorcycle Service Manual Supplement

All rights reserved. No parts of this publication may be reproduced, stored in a retrieval system, or transmitted in any form or by any means, electronic mechanical photocopying, recording or otherwise, without the prior written permission of Quality Assurance Department/Consumer Products & Machinery Group/Kawasaki Heavy Industries, Ltd., Japan.

No liability can be accepted for any inaccuracies or omissions in this publication, although every possible care has been taken to make it as complete and accurate as possible.

The right is reserved to make changes at any time without prior notice and without incurring an obligation to make such changes to products manufactured previously. See your Motorcycle dealer for the latest information on product improvements incorporated after this publication.

All information contained in this publication is based on the latest product information available at the time of publication. Illustrations and photographs in this publication are intended for reference use only and may not depict actual model component parts.

LIST OF ABBREVIATIONS

A	ampere(s)	lb	pound(s)
ABDC	after bottom dead center	m	meter(s)
AC	alternating current	min	minute(s)
ATDC	after top dead center	N	newton(s)
BBDC	before bottom dead center	Pa	pascal(s)
BDC	bottom dead center	PS	horsepower
BTDC	before top dead center	psi	pound(s) per square inch
°C	degree(s) Celsius	r	revolution
DC	direct current	rpm	revolution(s) per minute
F	farad(s)	TDC	top dead center
°F	degree(s) Fahrenheit	TIR	total indicator reading
ft	foot, feet	V	volt(s)
g	gram(s)	W	watt(s)
h	hour(s)	Ω	ohm(s)
L	liter(s)		



**WARNING
CONTAINS
ASBESTOS**

Breathing asbestos
dust is dangerous
to health

Follow safety
instructions

This warning may apply to any of the following components or any assembly containing one or more of these components:-

- Brake Shoes or Pads
- Clutch Friction Material
- Gaskets
- Insulators

SAFETY INSTRUCTIONS

- Operate if possible out of doors or in a well ventilated place.
- Preferably use hand tools or low speed tools equipped, if necessary, with an appropriate dust extraction facility. If high speed tools are used, they should always be so equipped.
- If possible, dampen before cutting or drilling.
- Dampen dust and place it in properly closed receptacle and dispose of it safely.

Read OWNER'S MANUAL before operating.

Foreword

This ZX400L Service Manual Supplement is designed to be used in conjunction with the ZX400H Motorcycle Service Manual (P/N 99924-1137-01). The maintenance and repair procedures described in this supplement are only those that are unique to the ZX400L motorcycle. Most service operation are described in the base Service Manual. Complete and proper servicing of the ZX400L motorcycle therefore requires both this supplement and the base Service Manual.

The base Service Manual and this Supplement are designed primarily for use by trained mechanics in a properly equipped shop. However, they contain enough detail and basic information to make them useful to the owner who desires to perform his own basic maintenance and repair work. A basic knowledge of mechanics, the proper use of tools, and workshop procedures must be understood in order to carry out maintenance and repair satisfactorily. Whenever the owner has insufficient experience or doubts his ability to do the work, all adjustments, maintenance, and repair should be carried out only by qualified mechanics.

In order to perform the work efficiently and to avoid costly mistakes, read the text, thoroughly familiarize yourself with the procedures before starting work, and then do the work carefully in a clean area. Whenever special tools or equipment are specified, do not use makeshift tools or equipment. Precision measurements can only be made if the proper instruments are used, and the use of substitute tools may adversely affect safe operation.

For the duration of your warranty period, especially, we recommend that all repairs and scheduled maintenance be performed in accordance with this service manual. Any owner maintenance or repair procedure not performed in accordance with this manual may void the warranty.

To get the longest life out of your Motorcycle:

- Follow the Periodic Maintenance Chart in the Service Manual.
- Be alert for problems and non-scheduled maintenance.
- Use proper tools and genuine Kawasaki Motorcycle parts. Special tools, gauges, and testers that are necessary when servicing Kawasaki Motorcycles are introduced by the Special Tool Manual. Genuine parts provided as spare parts are listed in the Parts Catalog.
- Follow the procedures in this manual carefully. Don't take shortcuts.

- Remember to keep complete records of maintenance and repair with dates and any new parts installed.

How to Use this Manual

In preparing this manual, we divided the product into its major systems. These systems became the manual's chapters. All information for a particular system from adjustment through disassembly and inspection is located in a single chapter.

The Quick Reference Guide shows you all of the product's system and assists in locating their chapters. Each chapter in turn has its own comprehensive Table of Contents.

The Periodic Maintenance Chart is located in the General Information chapter. The chart gives a time schedule for required maintenance operations.

If you want spark plug information, for example, go to the Periodic Maintenance Chart first. The chart tells you how frequently to clean and gap the plug. Next, use the Quick Reference Guide to locate the Electrical System chapter. Then, use the Table of Contents on the first page of the chapter to find the Spark Plug section.

Whenever you see these WARNING and CAUTION symbols, heed their instructions! Always follow safe operating and maintenance practices.

⚠ WARNING

This Warning symbol identifies special instructions or procedures which, if not correctly followed, could result in personal injury, or loss of life.

CAUTION

This caution symbol identifies special instructions or procedures which, if not strictly observed, could result in damage to or destruction of equipment.

This manual contains four more symbols (in addition to WARNING and CAUTION) which will help you distinguish different types of information.

NOTE

- *This note symbol indicates points of particular interest for more efficient and convenient operation.*
- Indicates a procedural step or work to be done.
- Indicates a procedural sub-step or how to do the work of the procedural step it follows. It also precedes the text of a WARNING, CAUTION, or NOTE.
- ★ Indicates a conditional step or what action to take based on the results of the test or inspection in the procedural step or sub-step it follows.

In most chapters an exploded view illustration of the system components follows the Table of Contents. In these illustrations you will find the instructions indicating which parts require specified tightening torque, oil, grease or a locking agent during assembly.

MODEL APPLICATION

Year	Model	Beginning Frame No.
1991	ZX400-L1	ZX400L-000001
1992	ZX400-L2	ZX400L-009001
1993	ZX400-L3	ZX400L-020001
1994	ZX400-L4	ZX400L-040001
1995	ZX400-L5	ZX400L-045001
1999	ZX400-L9	JKAZX400LLA060001

 **Kawasaki**
KAWASAKI HEAVY INDUSTRIES, LTD.
Consumer Product & Machinery Group

Part NO. 99924-1140-53

Printed in Japan

General Information

Table of Contents

Before Servicing.....	(1-2)
Model Identification.....	1-2
General Specifications.....	1-3
Periodic Maintenance Chart.....	1-5
Technical Information.....	1-7
Torque and Locking Agent.....	1-11
Cable, Wire, and Hose Routing.....	1-14

() : Refer to Base Manual

1-2 GENERAL INFORMATION

Model Identification

ZX400-L1 Left Side View:



ZX400-L1 Right Side View:



General Specifications

Item	ZX400-L1 ~ L5
Dimensions:	
Overall length	1 195 mm, (FG, NR, GR, SD) 2 090 mm
Overall width	700 mm
Overall height	1 080 mm
Wheelbase	1 385 mm
Road clearance	120 mm
Seat height	760 mm
Dry weight	159 kg
Curb weight:	
Front	93 kg
Rear	92 kg
Fuel tank capacity	16.0 L
Performance:	
Minimum turning radius	3.2 m
Engine:	
Type	4-stroke, DOHC, 4-cylinder
Cooling system	Liquid-cooled
Bore and stroke	57.0 × 39.0mm
Displacement	398 mL
Compression ratio	12.1
Maximum horsepower	47.8 kW (65 PS) @ 13 000 r/min (rpm) (UTAC's norm) (FR) 46.4 kW (- PS) @ 13 000 r/min (rpm),
Maximum Torque	36.3 N-m (3.7 kg-m, 26.8 ft-lb) @ 12 000 r/min (rpm)
Carburetion system	Carburetor, Keihin CVK-D32 × 4
Starting system	Electric starter
Ignition system	Battery and coil (transistorized)
Timing advance	Electronically advanced
Ignition timing	From 12.5° BTDC @ 1 200 r/min (rpm) to 45° BTDC @ 6 000 r/min (rpm),
Spark plug	NGK CR9EK or ND U27ETR
Cylinder numbering method	Left to right, 1-2-3-4
Firing order	1-2-4-3
Valve timing:	
Inlet:	Open 23° (BTDC)
	Close 65° (ABDC)
Duration	268°
Exhaust:	Open 57.5° (BBDC)
	Close 27.5° (ATDC)
Duration	265°
Lubrication system	Forced lubrication (wet sump with cooler)
Engine oil:	Grade SE, SF, or SG class
Viscosity	SAE 10W-40, 10W-50, 20W-40, or 20W-50
Capacity	3.0 L
Drive Train:	
Primary reduction system:	
Type	Gear
Reduction ratio	2.195 (90/41)

1-4 GENERAL INFORMATION

Items	ZX400-L1 ~ L5	
Clutch type	Wet multi disc	
Transmission:	Type	6-speed, constant mesh, return shift
	Gear ratios:	1st 2.846 (37/13)
		2nd 2.000 (38/19)
		3rd 1.578 (30/19)
		4th 1.318 (29/22)
		5th 1.200 (30/25)
		6th 1.111 (30/27)
Final drive system:	Type	Chain drive
	Reduction ratio	3.000 (45/15)
	Overall drive ratio	7.317 @Top gear
Frame:		
Type	Press, diamond	
Caster (rake angle)	23.5°	
Trail	82 mm	
Front tire:	Size, type	120/60 VR17, (FG) 120/60 ZR17 TUBELESS
	Mark	DUNLOP D202FA BRIDGESTONE CYROX-17
Rear tire:	Size, type	160/60 VR17, (FG) 160/60 ZR17 TUBELESS
	Mark	DUNLOP D202A BRIDGESTONE CYROX-20
Front suspension:	Type	Telescopic fork
	Wheel travel	120 mm
Rear suspension:	Type	Swingarm (uni-trak)
	Wheel travel	120 mm
Brake type:	Front	Dual discs
	Rear	Single disc
Electrical Equipment:		
Battery	12 V 8 Ah	
Headlight:	Type	Semi-sealed beam
	Bulb	Quartz-halogen 12 V 60/55 W, (UK) 12 V 60/35 W x 2
Tail/brake light	12 V 5/21 W x 2	
Alternator:	Type	Three-phase AC
	Rated output	23 A @10 000 r/min (rpm), 14 V

Specifications are subject to change without notice, and may not apply to every country.

(FG) : German Model

(GR) : Greek Model

(UK) : U.K. Model

(FR) : French Model

(NR) : Norwegian Model

(SD) : Swedish Model

1-6 GENERAL INFORMATION

OPERATION	FREQUENCY	† ODOMETER READING							See Page
		800 km	5,000 km	10,000 km	15,000 km	20,000 km	25,000 km	30,000 km	
Tire wear -- check *	Every	•	•	•	•	•	•	•	
Swing arm pivot, uni-trak linkage -- lubricate			•		•		•		
General lubrication -- perform		•	•	•	•	•	•	•	
Nut, bolt, and fastener tightness -- check *		•	•		•		•		
Coolant filter (B) -- clean *	year								

† : For higher odometer readings, repeat at the frequency interval established here.

* : Replace, add, adjust, clean, or torque if necessary.

Technical Information

Maintenance Free Battery

A maintenance free battery is installed in this model. The maintenance free battery is a sealed type, and so the electrolyte level check and topping-up cannot be performed.

(I) Construction

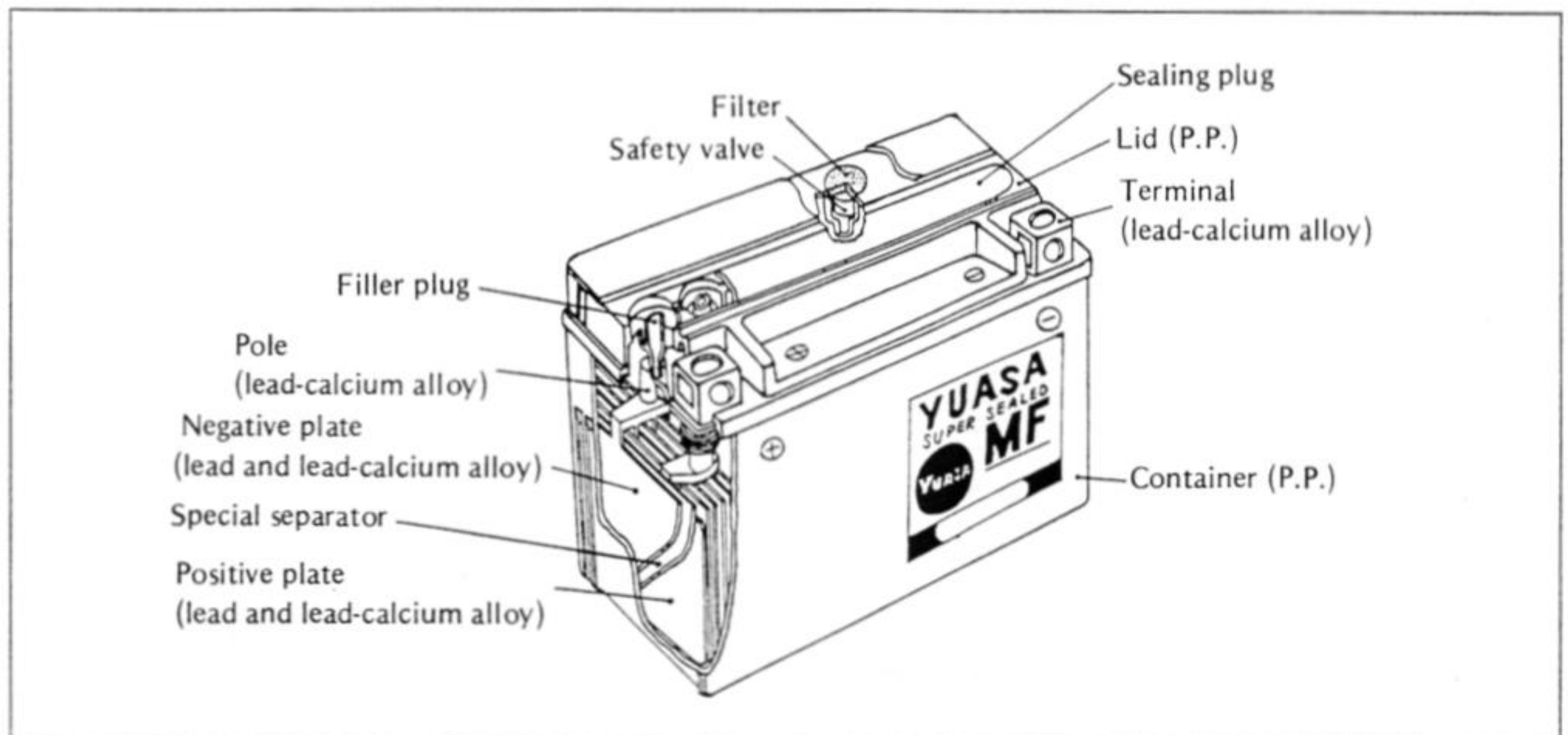

(II) Main Features

- 1) Maintenance free It is not necessary to check the electrolyte level and top-off the electrolyte.
- 2) No electrolyte leakage..... As the electrolyte is retained firmly in the special separators, there is no free electrolyte in the battery.
- 3) Instant activation system It can be used instantly after filling only the electrolyte without initial charge.
- 4) One-push motion electrolyte filling..... It is possible to fill the electrolyte by easy one-push motion.
- 5) Safety construction If the battery internal pressure rises abnormally high, the safety valve opens to release the gas inside the battery to restore the normal pressure and prevent the battery from rupturing. After restoring the normal pressure, the safety valve closes and the battery is sealed again. Moreover, a ceramic filter is disposed on top of the safety valve under the lid to remove risk of ignition or explosion caused by fire from outside.
- 6) Compact and high performance..... No presence of free electrolyte allows the battery made lower in height, thus resulting in enhanced volume efficiency. Moreover, gas being absorbed inside the battery eliminates the need for a gas exhaust tube.
- 7) Strong charge/discharge characteristics It can amply withstand deep charge/discharge cycles.

(III) Principle of Sealing Structure

A lead-acid battery operates under the following chemical reaction:

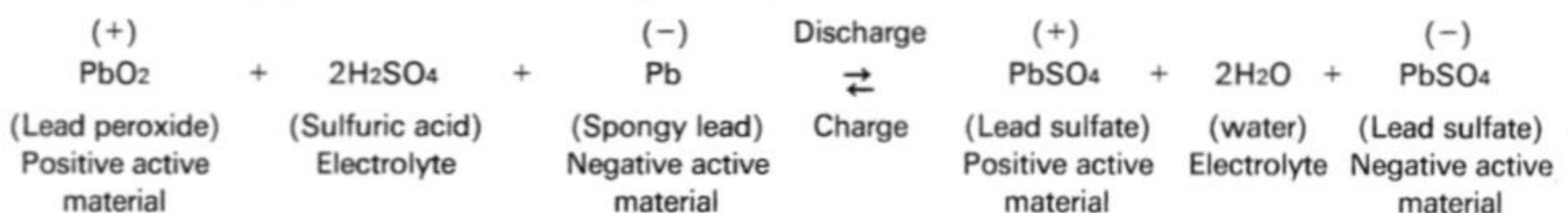

Normally in an ordinary lead-acid battery when it comes to an end of a charge, where the lead sulfate being a discharge product returns to lead peroxide and spongy lead, the charge current flowing thereafter is used exclusively to decompose electrolytically water from the electrolyte, thus resulting in generation of hydrogen gas from the negative plate and oxygen

1-8 GENERAL INFORMATION

gas from the positive plate. The gases so generated are released out of the battery, causing the amount of electrolyte decreased to require occasional water replenishment.

A maintenance free battery, however, is so designed that, when it is overcharged, even if the positive plate is fully charged, the negative plate remains not fully turned to spongy lead. Therefore, even when the positive plate is overcharged generating oxygen gas, the negative plate is not fully charged, hence generating no hydrogen gas.

Moreover, the oxygen gas generated from the positive plate immediately reacts with the charged active material on the negative plate, and returns to water, with the ultimate result of no water loss.

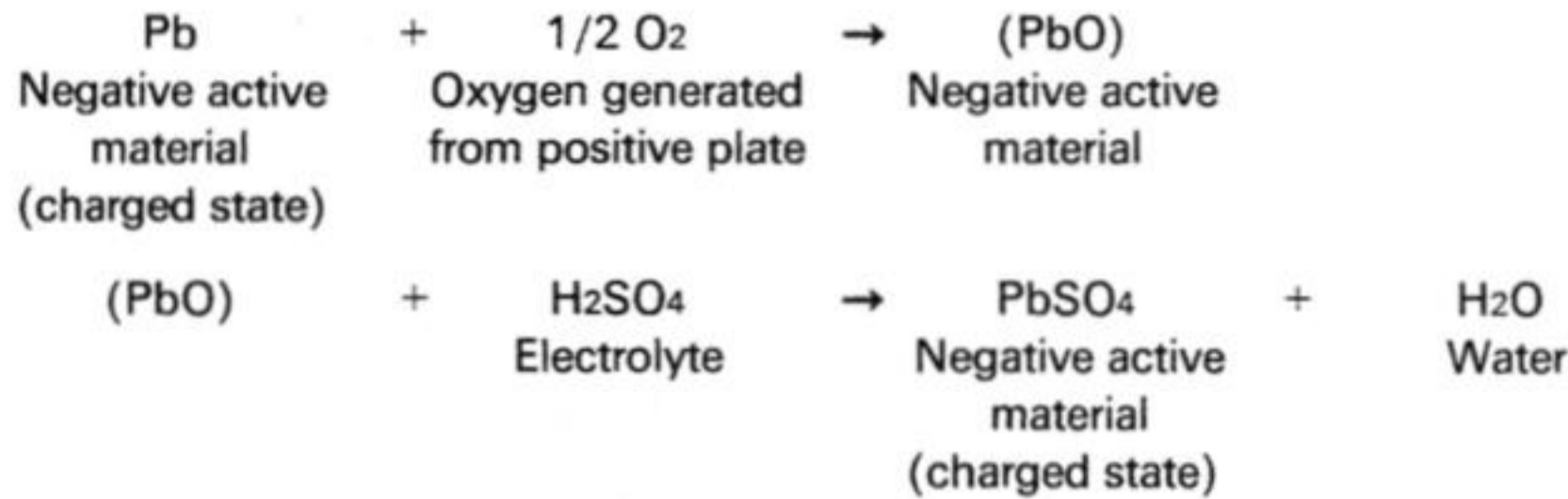

Thus, the negative plate is made as not to get fully charged. Even if the overcharge continues, the oxygen gas generated inside the battery is absorbed by the negative plate, a process called oxygen cycle, which theoretically prevents water loss, and allows the battery to be sealed.

(IV) Filling the Battery with Electrolyte

CAUTION

Do not remove the aluminum seal sheet sealing the filler ports until just before use.
Be sure to use the dedicated electrolyte container for correct electrolyte volume.

- Check to see that there is no peeling, tears or holes in the sealing sheet.
- Place the battery on a level surface.
- Remove the sealing sheet.
- When removing, check to hear an air-sucking sound "Shoosh!" from filler ports.

NOTE

- A battery whose sealing sheet has any peeling, tears, holes, or from which the air-sucking sound was not heard requires a refreshing charge (initial charge).

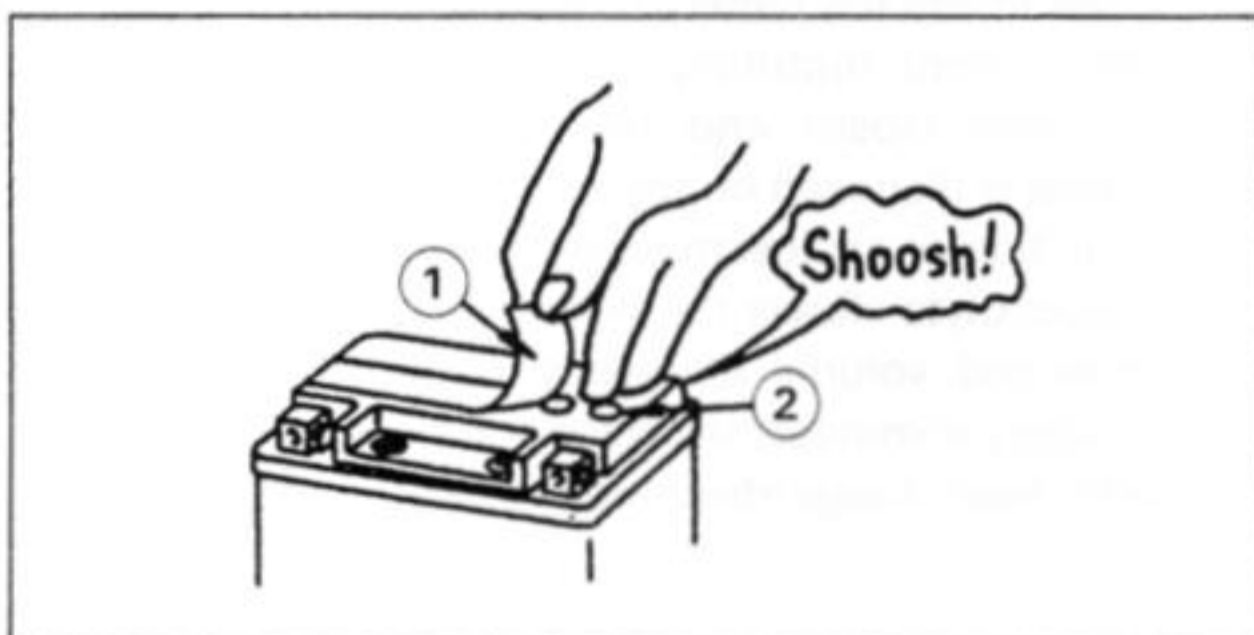

1. Sealing Sheet 2. Filler Ports

- Take the electrolyte container out of the vinyl bag.
- Detach the strip of caps from the container.

NOTE

- Do not discard the strip of caps because it is used as the battery plugs later.
- Do not peel back or pierce the sealed areas.

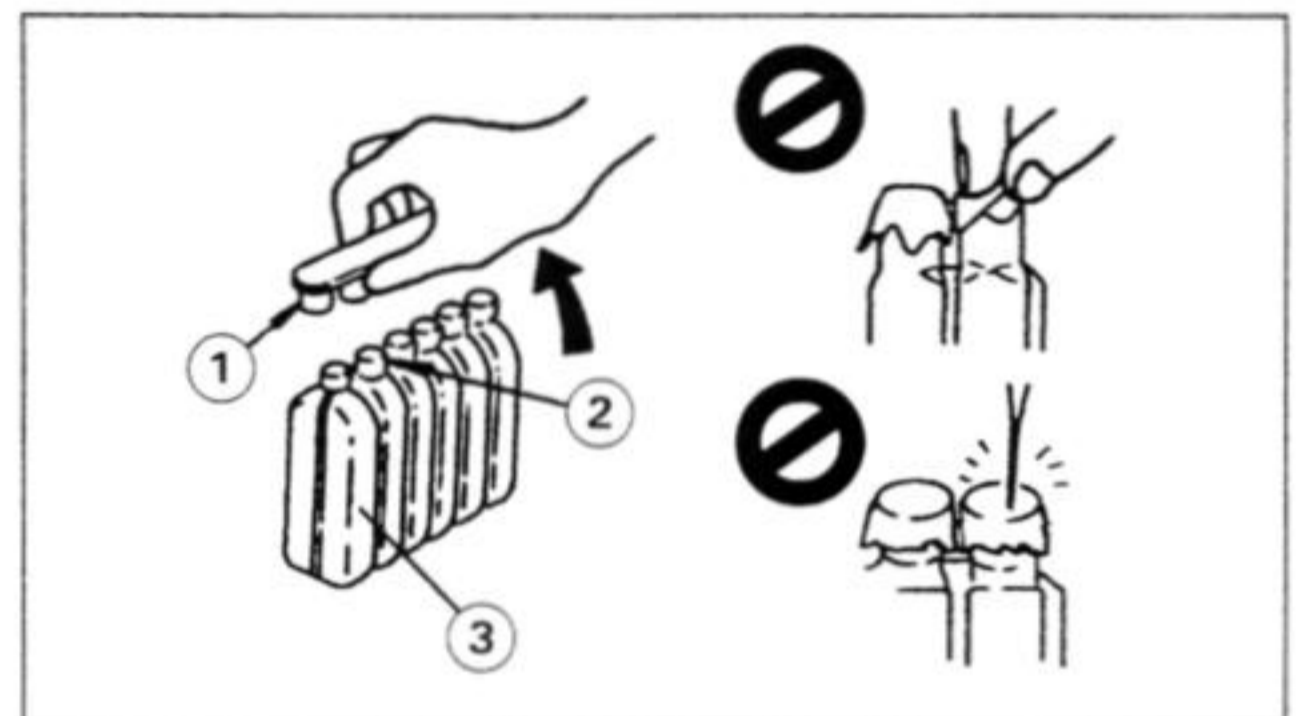

1. Strip of Caps 3. Container
2. Sealed Areas

- Place the electrolyte container upside down with the six sealed areas in line with the six battery filler ports.
- Push the container down strongly enough to break the seals. Now the electrolyte should start to flow into the battery.

NOTE

- Do not tilt the container as the electrolyte flow may be interrupted.

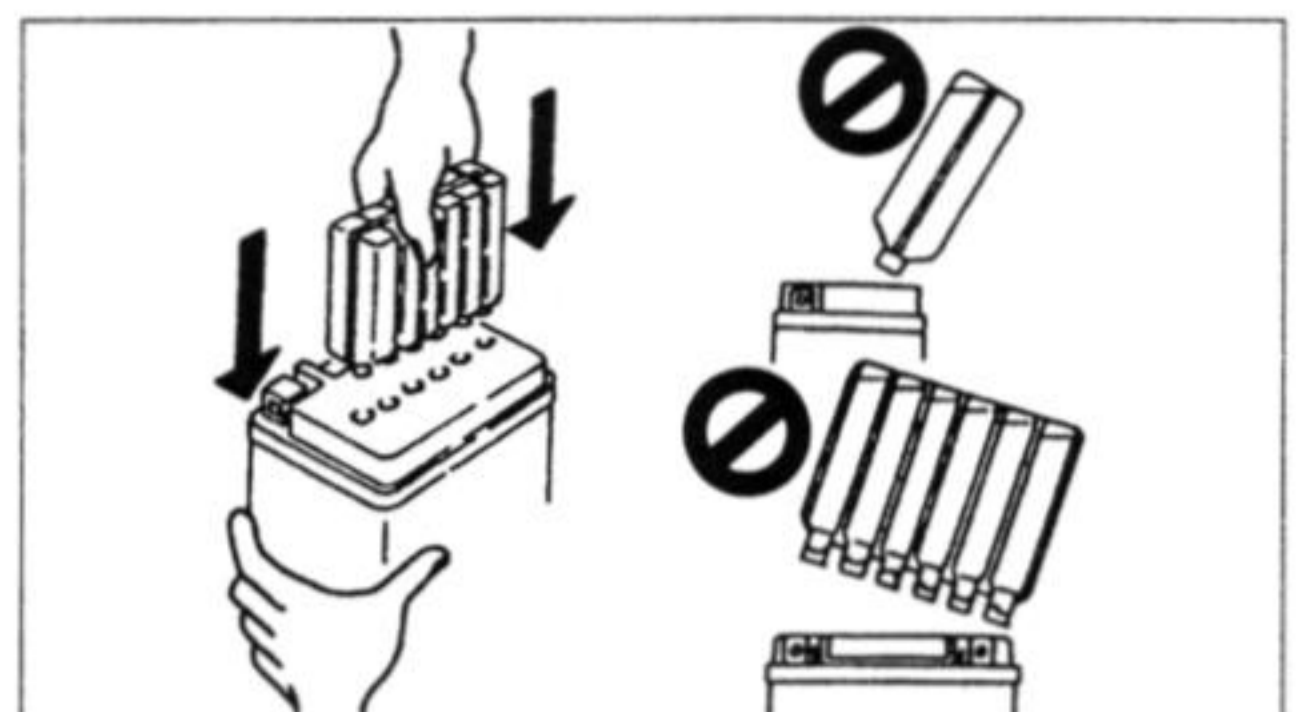

- Make sure air bubbles are coming up from all six filler ports.
- Leave the container this way for 5 minutes or longer.

GENERAL INFORMATION 1-9

NOTE

- If no air bubbles are coming up from a filler port, tap the bottom of the bottle two or three times. Never remove the container from the battery.

CAUTION

Fill until the container is completely emptied.

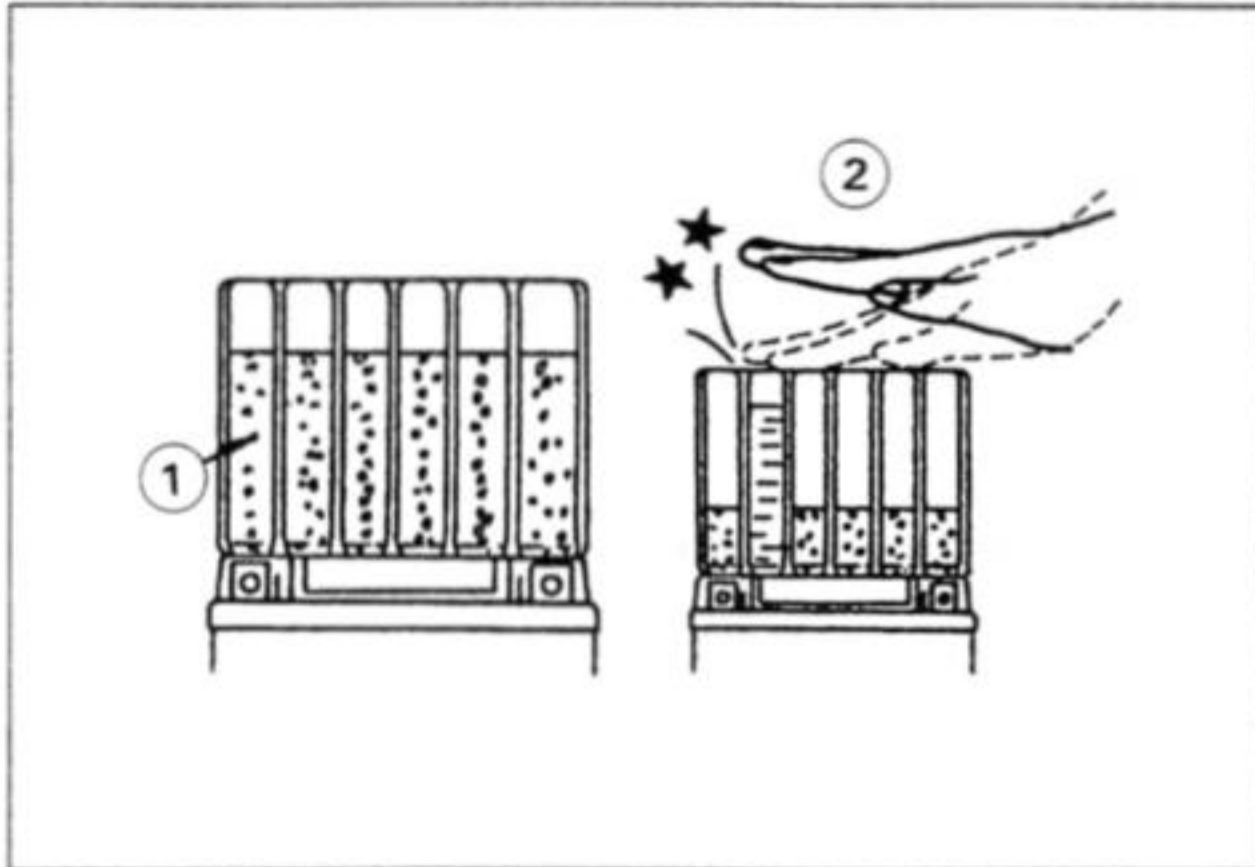

1. Air Bubble

2. Tap

- Be certain that all the electrolyte has flowed out.
- Tap the bottom the same way as above if there is any electrolyte left in the container.

(V) Initial Charge

While a maintenance free battery can be used after only filling with electrolyte, a battery may not be able to sufficiently move a starter motor to start an engine in the cases shown in the table below, where an initial charge is required before use. However, if a battery shows a terminal voltage of higher than 12.5 V after 10 minutes of filling (Note 1), no initial charge is necessary.

Condition requiring initial charge	Charging method
At low temperatures (lower than 0°C)	0.9 A × 2 ~ 3 hours
Battery has been stored in high temperature and humidity.	0.9 A × 15 ~ 20 hours
Seal has been removed, or broken – peeling, tear or hole. (If you did not hear the air-sucking sound "Shoosh!" as you removed the seal.)	
Battery as old as 2 years or more after manufacture. Battery manufacturing date is printed on battery top. Example) <u>12</u> <u>10</u> <u>90</u> <u>T1</u> Day Month Year Mfg. location	

Note 1 : Terminal voltage – To measure battery terminal voltage, use a digital voltmeter.

- Now pull the container gently out of the battery.
- Let the battery sit for **20** minutes. During this time, the electrolyte permeates the special separators and the gas generated by chemical reaction is released.
- Fit the strip of caps tightly into the filler ports until the strip is at the same level as the top of the battery.

NOTE

- Do not hammer. Press down evenly with both hands.

CAUTION

Once you install the strip of caps after filling the battery, never remove it, nor add any water or electrolyte.

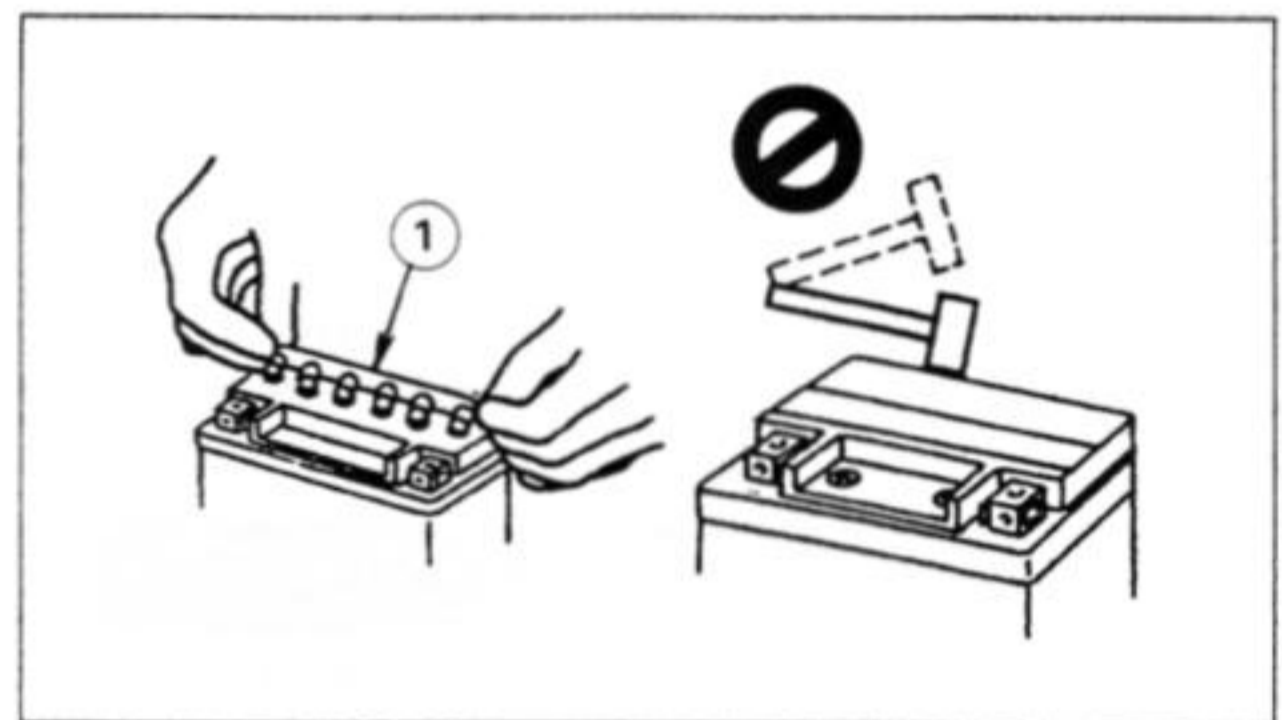

1. Strip of Caps

1-10 GENERAL INFORMATION

(VI) Precautions

- 1) No need of topping-up
No topping-up is necessary in this battery until it ends its life under normal use. Forcibly prying off the sealing plug to add water is very dangerous. Never do that.
- 2) Refreshing charge
If an engine will not start, a horn sounds weak, or lamps are dim, it indicates the battery has been discharged. Give refresh charge for 5 to 10 hours with charge current shown in the specification (see the Electrical System chapter).
When a fast charge is inevitably required, do it following precisely the maximum charge current and time conditions indicated on the battery.

CAUTION

This battery is designed to sustain no unusual deterioration if refresh-charged according to the method specified above. However, the battery's performance may be reduced noticeably if charged under conditions other than given above. Never remove the sealing plug during refresh charge. If by chance an excessive amount of gas is generated due to overcharging, the safety valve operates to keep the battery safe.

- 3) When you do not use the motorcycle for months.
Give a refresh charge before you store the motorcycle and store it with the negative lead removed. Give a refresh charge every six months during storage.
- 4) Battery life
If the battery will not start the engine even after several refresh charges, the battery has exceeded its useful life. Replace it. (Provided, however, the vehicle's starting system has no problem.)

⚠ WARNING

Keep the battery away from sparks and open flames during charging, since the battery gives off an explosive gas mixture of hydrogen and oxygen. When using a battery charger, connect the battery to the charger before turning on the charger. This procedure prevents sparks at the battery terminals which could ignite any battery gases. No fire should be drawn near the battery, or no terminals should have the tightening loosened. The electrolyte contains sulfuric acid. Be careful not to have it touch your skin or eyes. If touched, wash it off with liberal amount of water. Get medical attention if severe.

(VII) Interchangeability with Ordinary Battery

A maintenance free battery can fully display its performance only when combined with a proper vehicle electric system. Therefore, replace a maintenance free battery only on a motorcycle which was originally equipped with a maintenance free battery.

Be careful, if a maintenance free battery is installed on a motorcycle which had an ordinary battery as original equipment, the maintenance free battery's life will be shortened.

GENERAL INFORMATION 1-11

Torque and Locking Agent

The following tables list the tightening torque for the major fasteners requiring use of a non-permanent locking agent or liquid gasket.

Letters used in the "Remarks" column mean:

- L** : Apply a non-permanent locking agent to the threads.
- LG** : Apply liquid gasket to the threads.
- M** : Apply molybdenum disulfide grease.
- O** : Apply an oil to the threads and seating surface.
- S** : Tighten the fasteners following the specified sequence.
- SS** : Apply silicone sealant.
- St** : Stake the fasteners to prevent loosening.
- R** : Replace the part.

The table below, relating tightening torque to thread diameter, lists the basic torque for the bolts and nuts. Use this table for only the bolts and nuts which do not require a specific torque value. All of the values are for use with dry solvent-cleaned threads.

Basic Torque for General Fasteners

Threads dia. (mm)	Torque		
	N-m	kg-m	ft-lb
5	3.4 ~ 4.9	0.35 ~ 0.50	30 ~ 43 in-lb
6	5.9 ~ 7.8	0.60 ~ 0.80	52 ~ 69 in-lb
8	14 ~ 19	1.4 ~ 1.9	10.0 ~ 13.5
10	25 ~ 34	2.6 ~ 3.5	19.0 ~ 25
12	44 ~ 61	4.5 ~ 6.2	33 ~ 45
14	73 ~ 98	7.4 ~ 10.0	54 ~ 72
16	115 ~ 155	11.5 ~ 16.0	83 ~ 115
18	165 ~ 225	17.0 ~ 23.0	125 ~ 165
20	225 ~ 325	23 ~ 33	165 ~ 240

Fastener	Torque			Remarks
	N-m	kg-m	ft-lb	
Fuel System: Carburetor Duct Mounting Bolts	2.9	0.3	26 in-lb	
Cooling System: Coolant Drain Plugs (Cylinder)	8.8	0.90	78 in-lb	
Thermostatic Housing Bolt (cylinder head)	9.8	1.0	7.0	L
Cooling Fan Switch	18	1.8	13.0	
Water Temperature Sensor	7.8	0.80	69 in-lb	SS
Water Pump Mounting Bolt	9.8	1.0	7.0	
Water Pump Pipe Mounting Bolt	9.8	1.0	7.0	
Radiator Hose Clamp Bolts	2.0	0.2	17 in-lb	
Radiator Horse Fitting Mounting Bolt (cylinder)	9.8	1.0	7.0	L
Cooling Fan Mounting Bolt	3.4	0.35	30 in-lb	
Engine Top End: Cylinder Head Cover Bolts	9.8	1.0	7.0	
Camshaft Chain Guide Bolt (Rear)	25	2.5	18.0	
Chain Tensioner Mounting Bolt	9.8	1.0	7.0	L
Chain Tensioner Lock Bolt	5.9	0.6	52 in-lb	
Rocker Shaft Plug	9.8	1.0	7.0	
Upper Chain Guide Bolt	12	1.2	8.5	
Inlet Pipe Mounting Bolt (carburetor holder)	8.8	0.90	78 in-lb	
Outlet Pipe Mounting Bolt (cylinder head)	4.9	0.50	43 in-lb	
Camshaft Cap Bolts	12	1.2	8.5	
Cylinder Head Bolts: 8 mm	25	2.5	18.0	
6 mm	12	1.2	8.5	
Muffler Body Mounting Nuts	27	2.8	20	
Clutch Clutch Cover Bolts	9.8	1.0	7.0	L (two bolts)
Clutch Cover Damper Bolts	9.8	1.0	7.0	L
Clutch Hub Nut	130	13.5	98	R
Clutch Spring Bolts	12	1.2	8.5	
Engine Lubrication System: Engine Drain Plug	20	2.0	14.5	

GENERAL INFORMATION 1-13

Fastener	Torque			Remarks
	N-m	kg-m	ft-lb	
Brake Lever Pivot Locknut	5.9	0.60	52 in-lb	
Front Brake Light Switch Mounting Screw	1.2	0.12	10 in-lb	
Brake Pedal Mounting Bolt	25	2.5	18.0	
Rear Master Cylinder Rod Locknut	18	1.8	13.0	
Caliper Mounting Bolts (Rear)	25	2.5	18.0	
Rear Master Cylinder Mounting Bolts	23	2.3	16.5	
Torque Link Bolt	25	2.5	18.0	
Torque Link Nut	25	2.5	18.0	
Suspensions:				
Front Fork Clamp Bolts (Upper, Lower)	20	2.0	14.5	
Front Fork Top Plug	34	3.5	25	
Piston Rod Nut	25	2.5	18.0	
Front Fork Bottom Bolts	20	2.0	14.5	L
Front Axle Clamp Bolts	20	2.0	14.5	
Rear Shock Absorber Spring Adjuster Locknut	88	9.0	65	
Rear Shock Absorber Mounting Nuts	49	5.0	36	
Swing Arm Pivot Shaft Nut	110	11.0	80	
Rocker Arm Nuts	49	5.0	36	
Tie-Rod Nuts	49	5.0	36	
Steering:				
Steering Stem Head Nut	54	5.5	40	
Steering Stem Nut	4.9	0.5	43 in-lb	
Handlebar Mounting Bolts	34	3.5	25	
Handlebar Holder Mounting Bolts	9.8	1.0	7.0	
Handlebar Holder Clamp Bolt	23	2.3	16.5	
Front Fork Clamp Bolts (Upper)	20	2.0	14.5	
Frame:				
Step Holder Mounting Bolts	34	3.5	25	
Side Stand Bracket Bolts	25	2.5	18.0	L
Electrical/Starter Motor Clu				
Spark Plugs	13	1.3	9.5	
Pickup Coil Cover Bolts	9.8	1.0	7.0	L
				(one bolt only)
Timing Check Plug	2.5	0.25	22 in-lb	hand-tight
Pickup Coil Bolt	5.9	0.6	52 in-lb	
Timing Rotor Allen Bolts	25	2.5	18.0	
Alternator				
Alternator Cover Bolts	9.8	1.0	7.0	
Alternator Rotor Bolt	78	8.0	58	
Alternator Stator Allen Bolt	8.3	0.85	74 in-lb	
Alternator Stator Lead Clamp Bolt	8.3	0.85	74 in-lb	
Alternator Cover Mating Surfaces	-	-	-	SS
				(three portions)
Starter Motor Mounting Bolts	9.8	1.0	7.0	
Starter Motor Clutch Allen Bolt	34	3.5	25	L
Battery Ground Lead Bolt (Crankcase)	9.8	1.0	7.0	
Tail Lamp Mounting Nuts	5.9	0.6	52 in-lb	
Cooling Fan Switch	18	1.8	13.0	
Water Temperature Sensor	7.8	0.80	69 in-lb	SS
Oil Pressure Switch	15	1.5	11.0	SS
Neutral Switch	15	1.5	11.0	

1-14 GENERAL INFORMATION

Cable, Wire, and Hose Routing

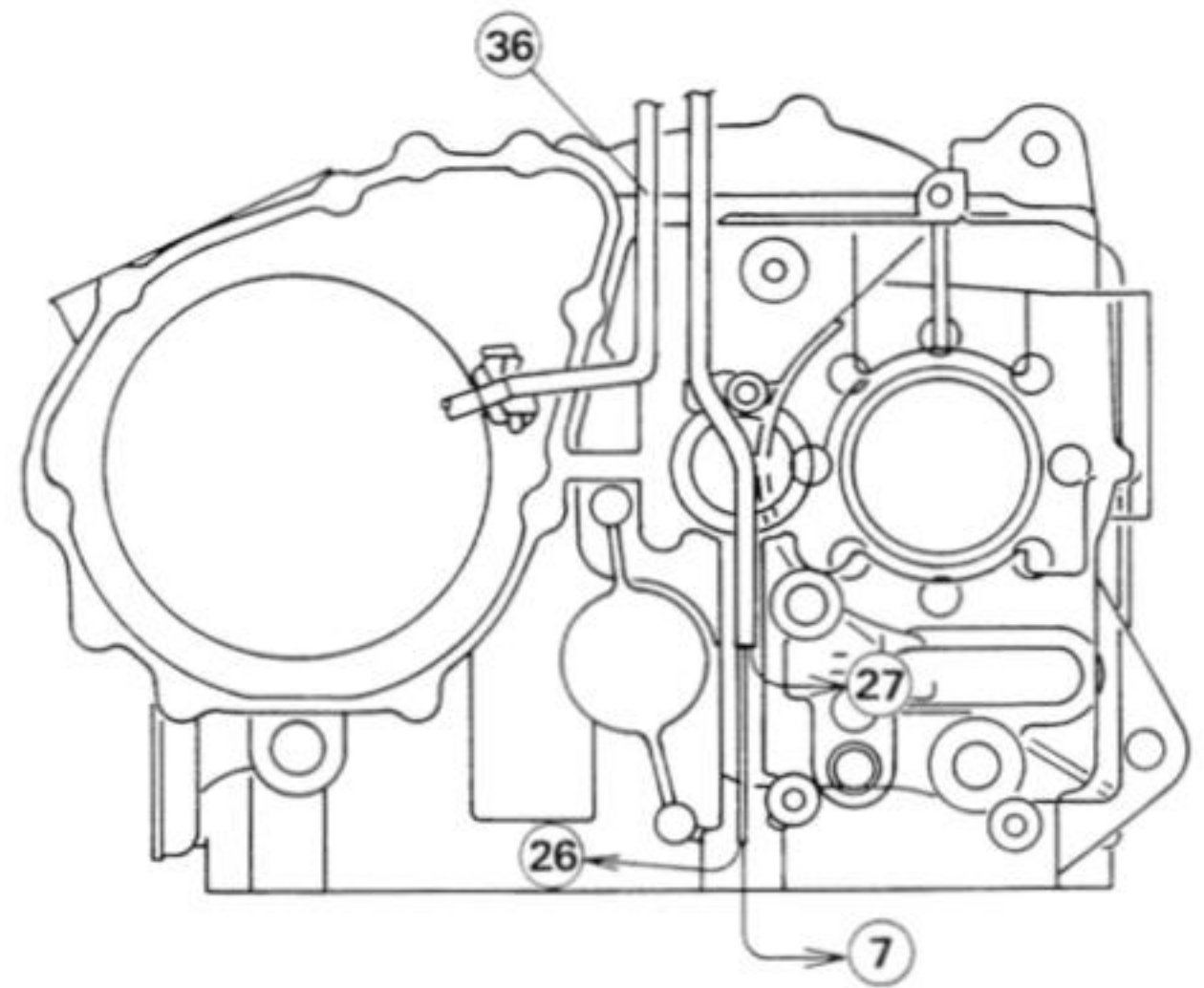
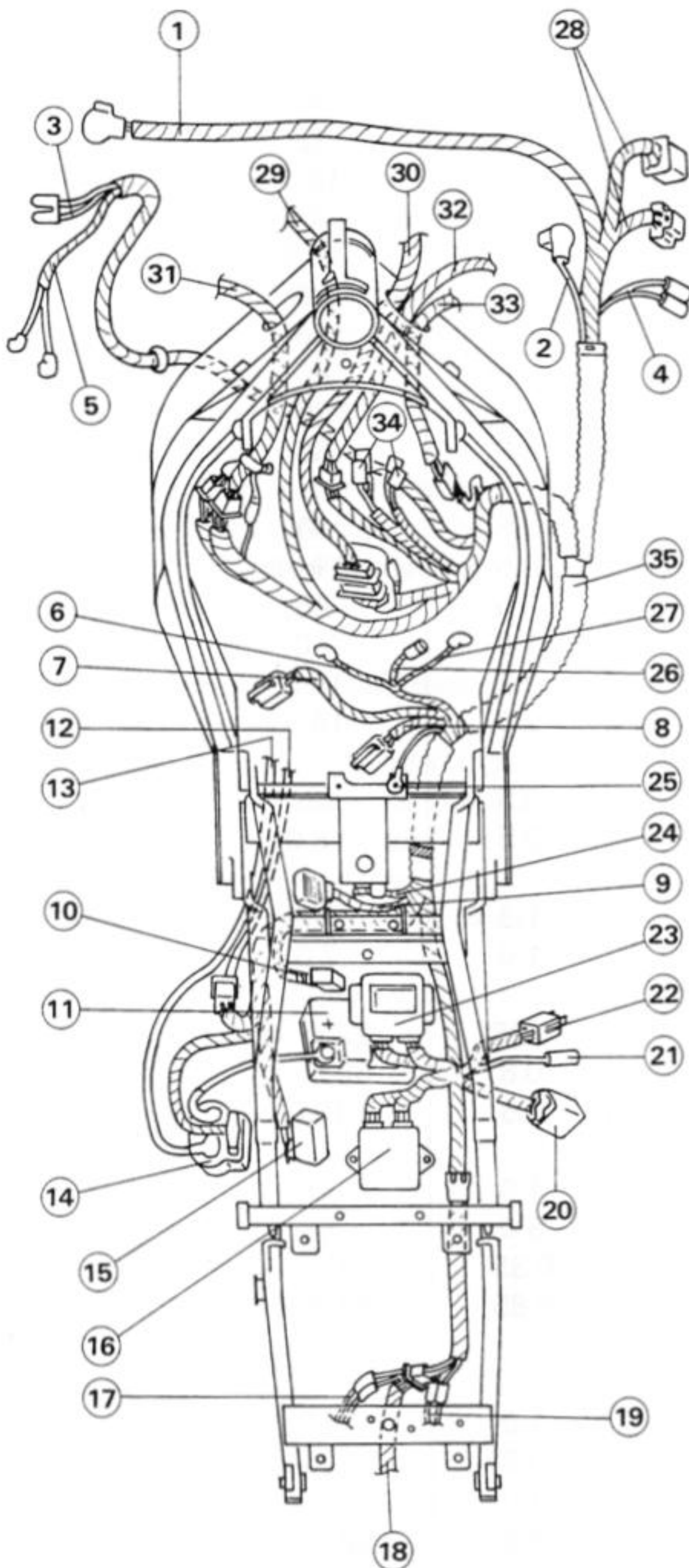

1. Headlight Lead
2. Headlight Lead (U.K. Model)
3. Left Turn Signal Light Leads (Front)
4. Right Turn Signal Light Leads (Front)
5. Cooling Fan Switch Lead
6. Water Temperature Sensor Lead
7. Side Stand Switch Lead
8. Fuel Pump Lead
9. Regulator Lead
10. Headlight Relay Lead (U.K. Model)
11. Battery
12. Alternator Lead
13. Starter Motor Lead
14. Starter Relay
15. Fuel Pump Relay
16. IC Igniter
17. Left Turn Signal Light Leads (Rear)
18. Tail/Brake and License Lights Lead
19. Right Turn Signal Light Leads (Rear)
20. Turn Signal Relay
21. Battery Lead (-)
22. Pickup Coil Lead Connector
23. Junction Box
24. Rear Brake Light Switch Lead
25. Engine Ground Terminal
26. Oil Pressure Switch Lead
27. Neutral Switch Lead
28. Meters Leads
29. Horn Lead
30. Ignition Switch Lead
31. Left Handlebar Switch Lead
32. Cooling Fan Motor Lead
33. Right Handlebar Switch Lead
34. Ignition Coil Leads
35. Main Harness
36. Stator Coil Lead

GENERAL INFORMATION 1-15

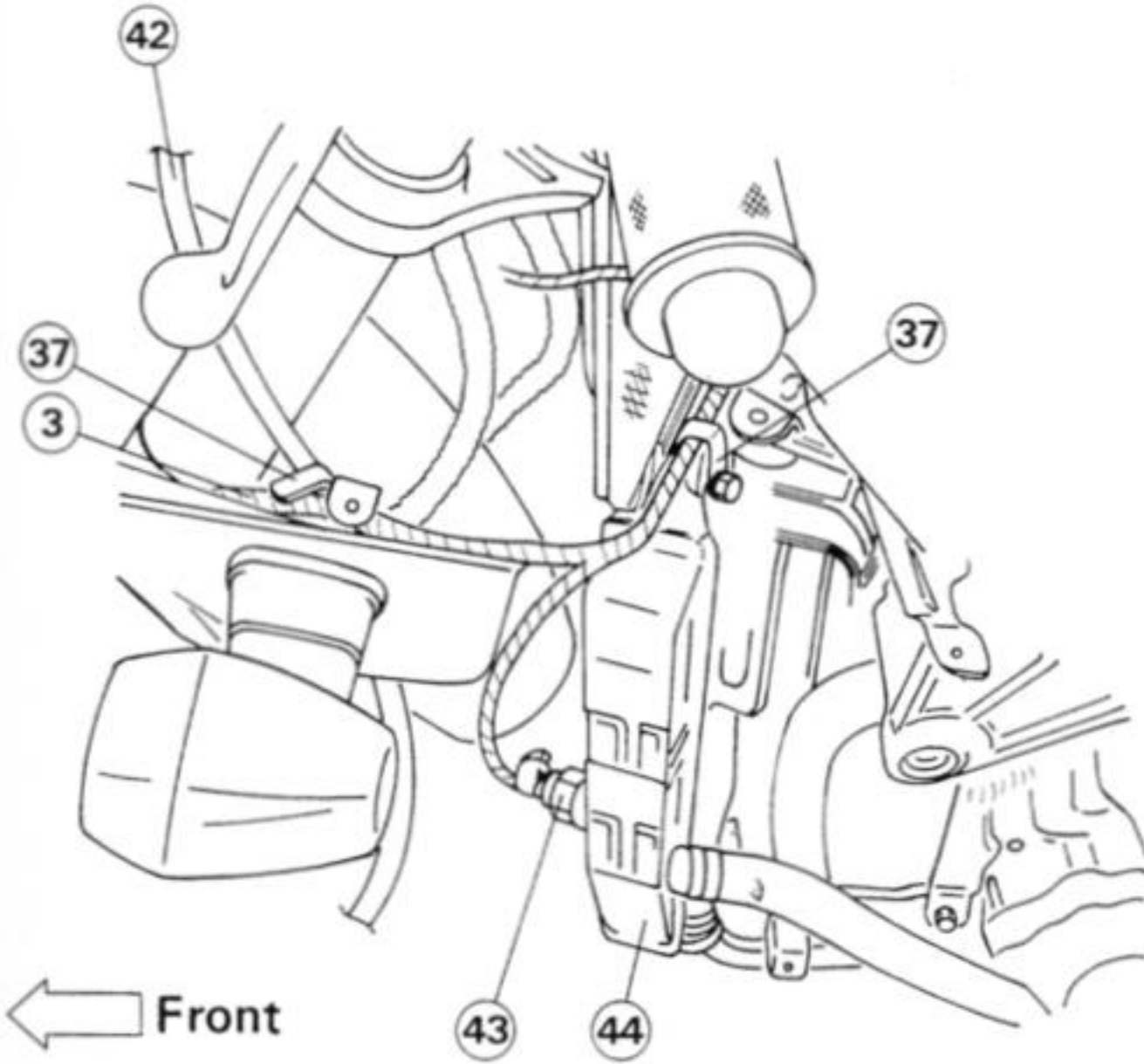
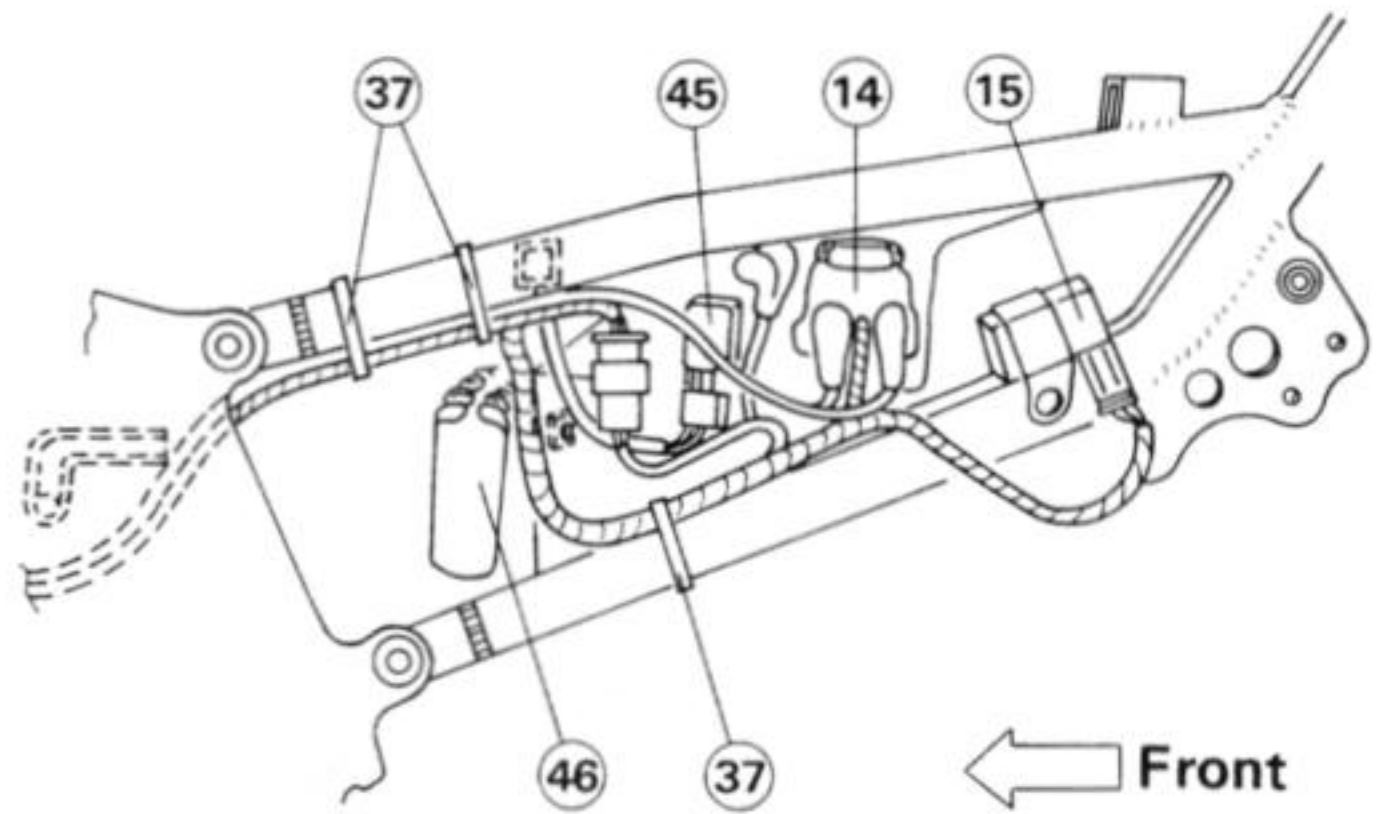
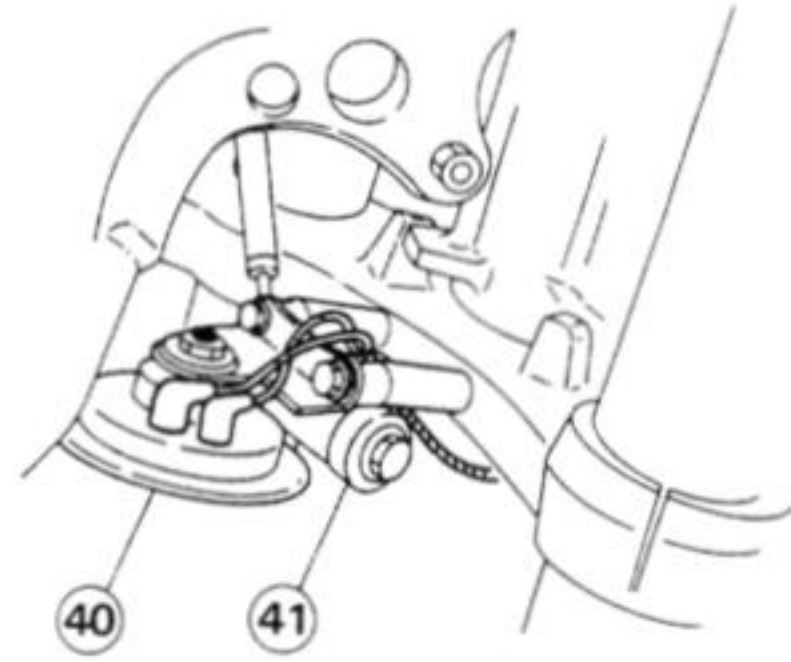
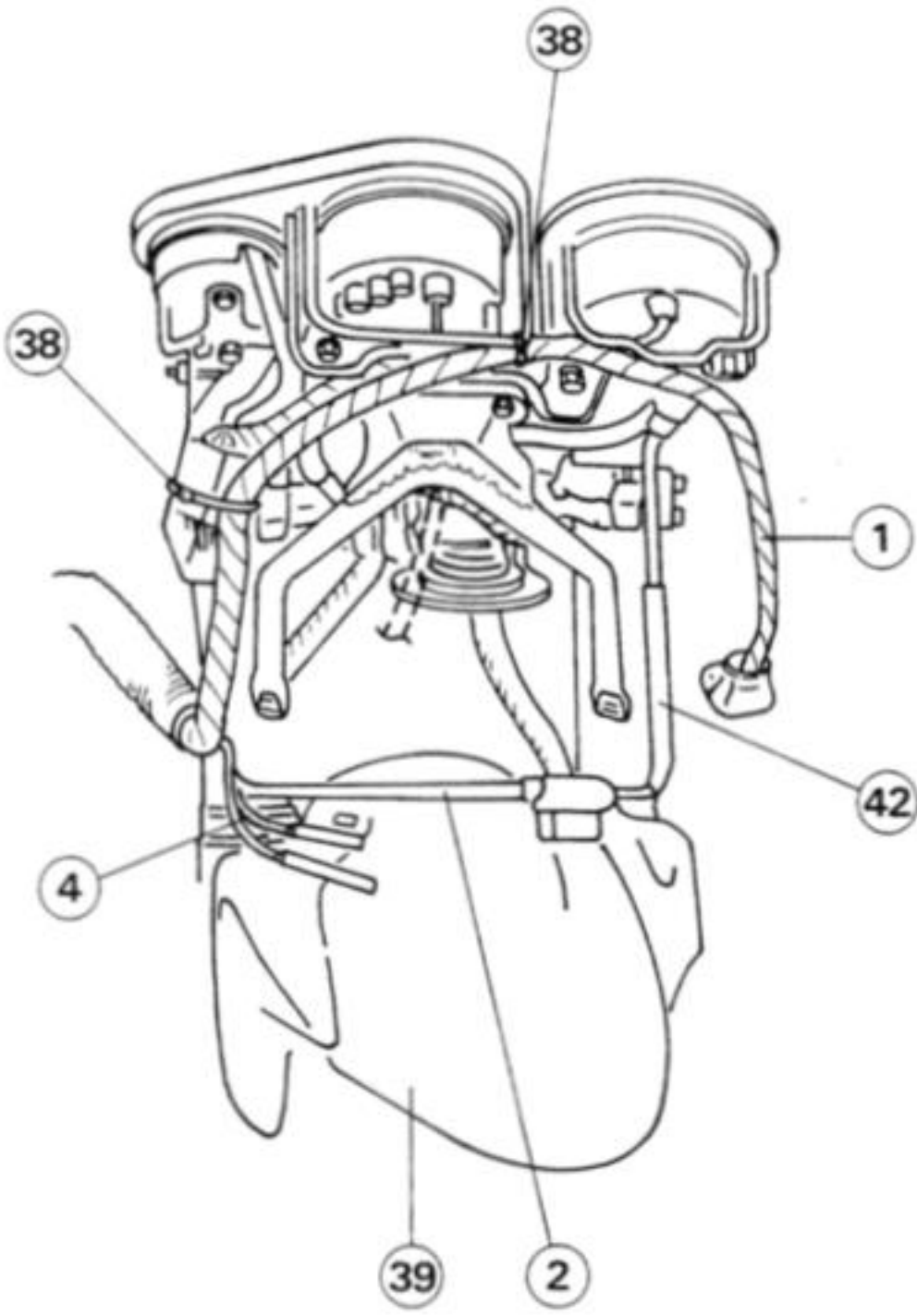

- 37. Clamp
- 38. Band
- 39. Front Fender
- 40. Horn
- 41. Brake Hose Joint

- 42. Speedometer Cable
- 43. Cooling Fan Switch
- 44. Radiator
- 45. Headlight Relay (U.K. Model)
- 46. Regulator

1-16 GENERAL INFORMATION

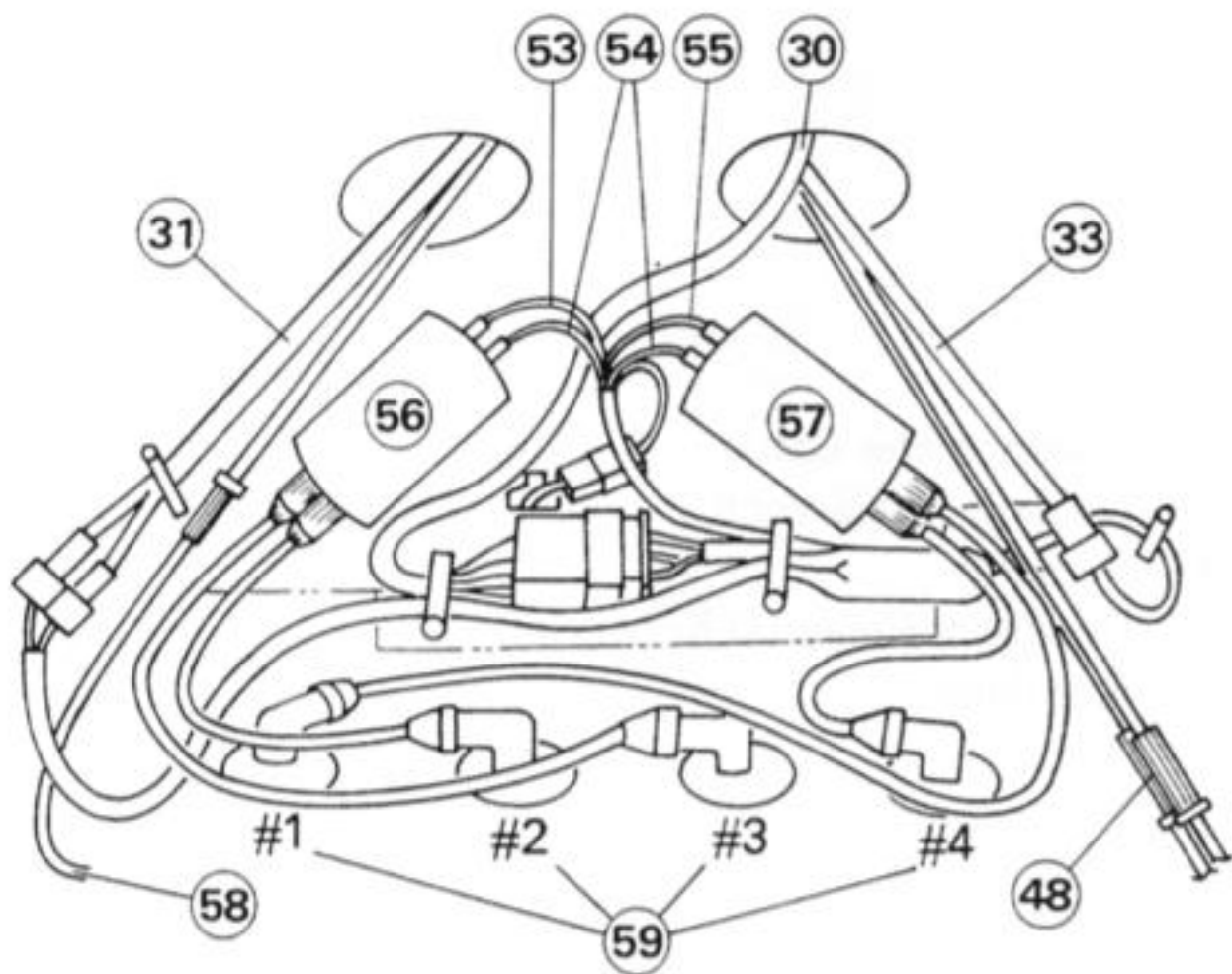
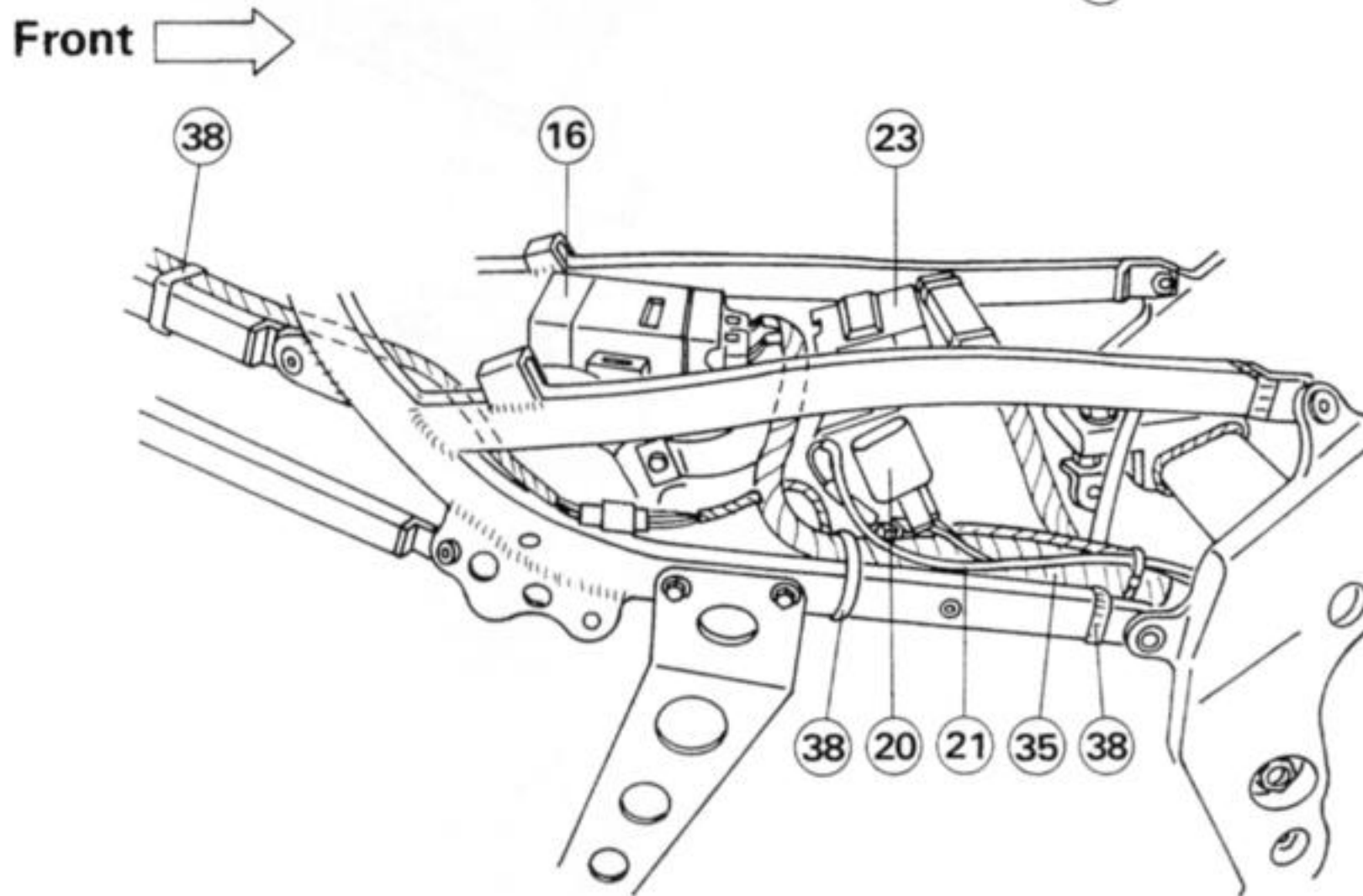
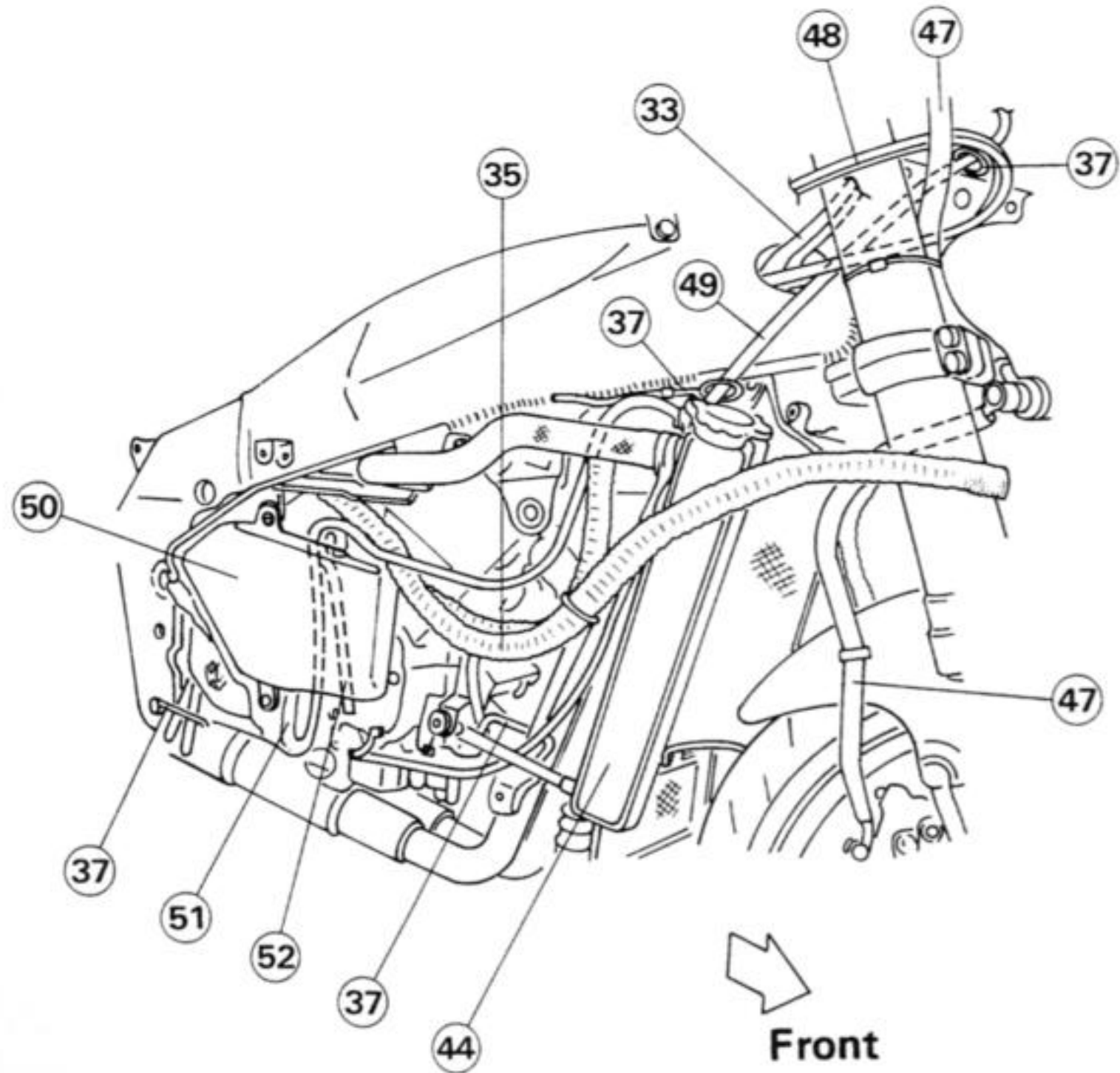

- 47. Front Brake Hose
- 48. Throttle Cable
- 49. Clutch Cable
- 50. Coolant Reservoir Tank
- 51. Coolant Reservoir Tank Hose
- 52. Reservoir Tank Overflow Hose
- 53. Green Lead
- 54. Red Leads
- 55. Black Lead
- 56. Ignition Coil (#2, #3)
- 57. Ignition Coil (#1, #4)
- 58. Choke Cable
- 59. Spark Plugs

Fuel System

Table of Contents

Exploded View	2-2
Specifications	2-4
Special Tools	2-4
Carburetors	2-5
Carburetor Installation	2-5
Coolant Filter Cleaning (U.K. and L4 ~ L5 Models)	2-5

2-2 FUEL SYSTEM

Exploded View

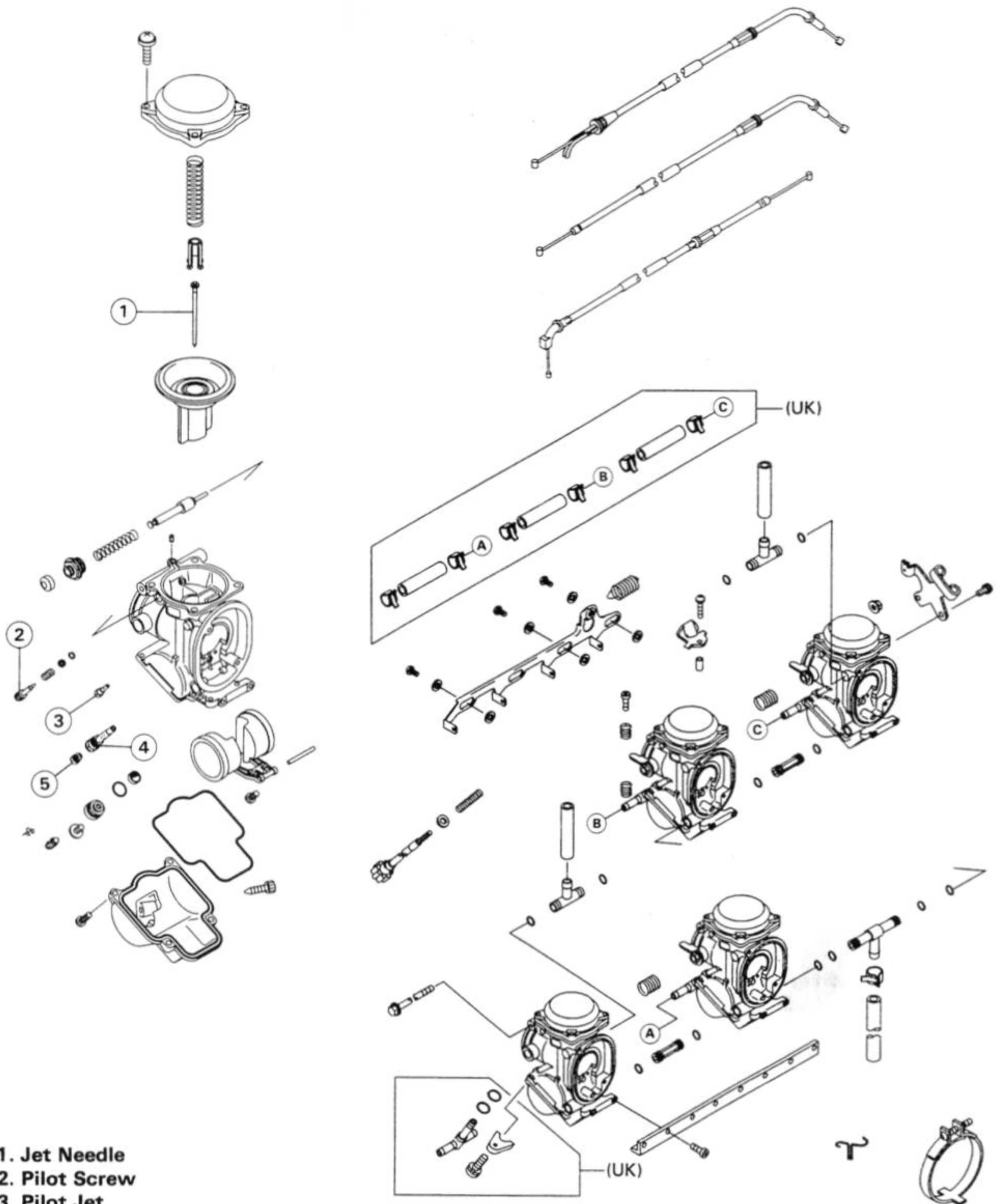

UK : U.K. and L4 ~ L5 Models

Pressure Cable Luber: K5601-9021

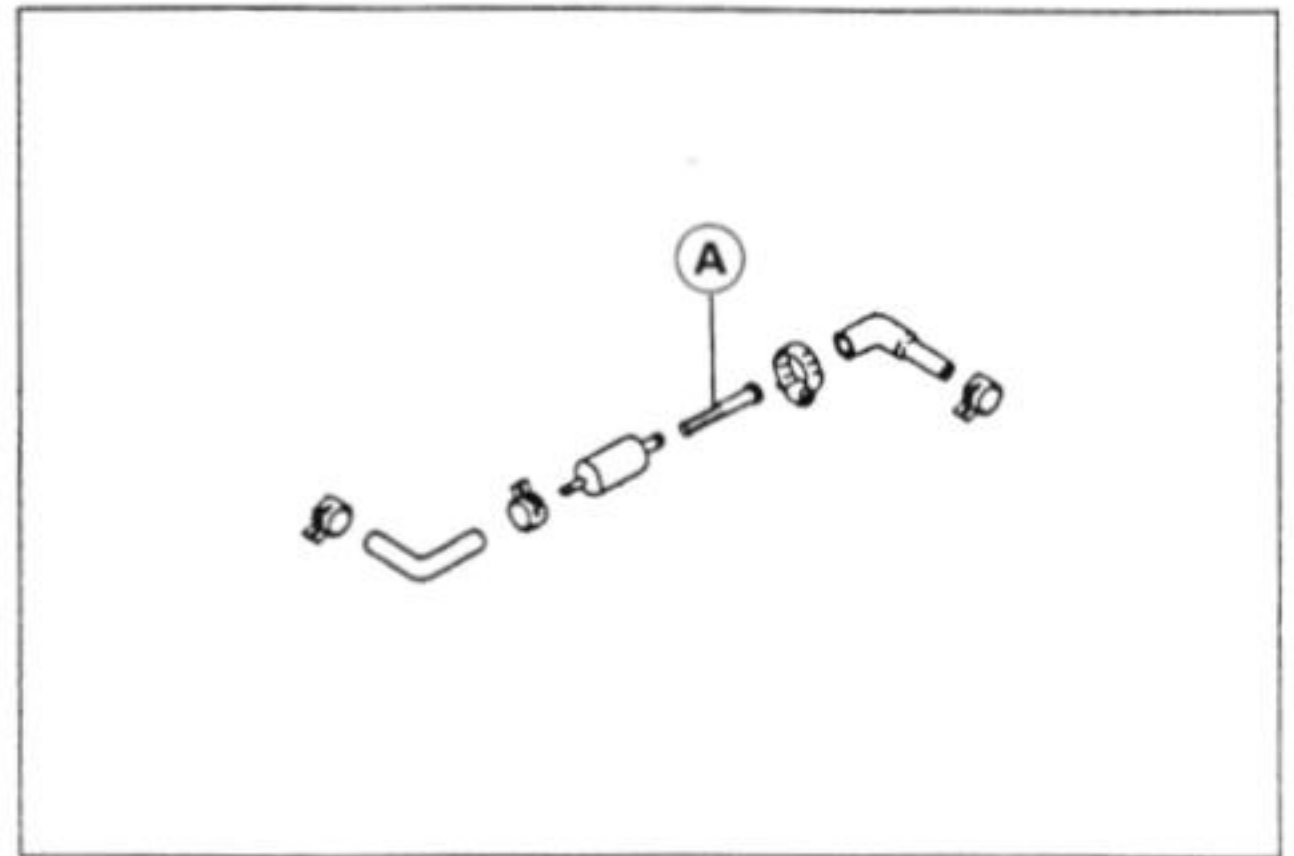
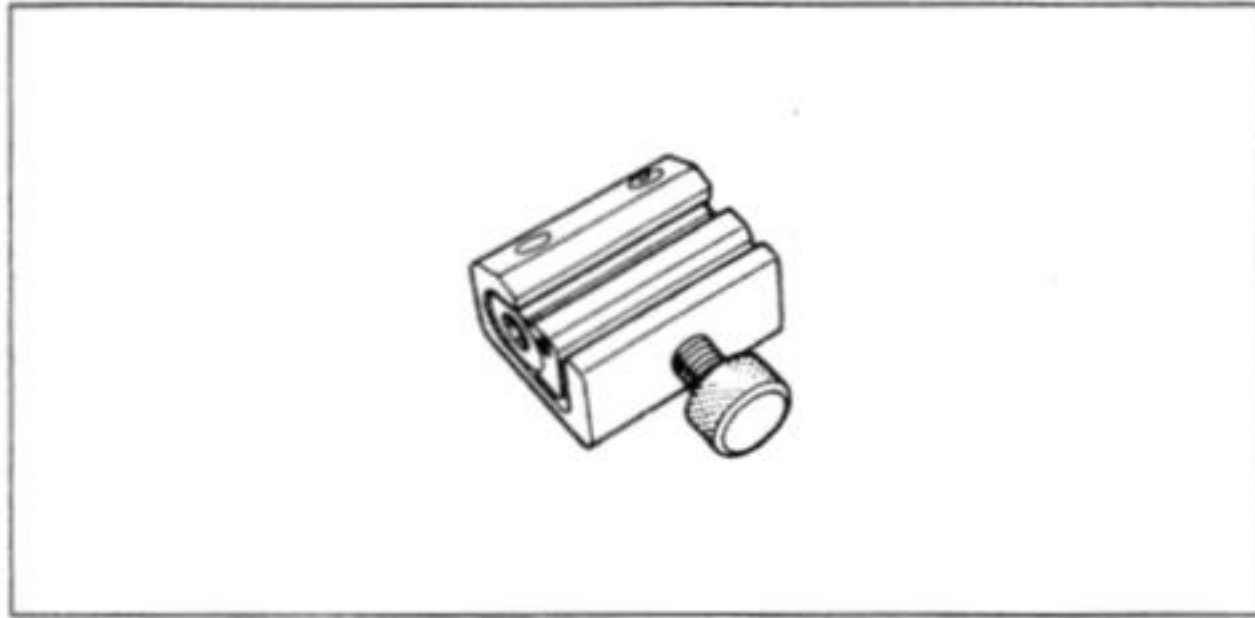

A. Coolant Filter

- Blow off dirt and sediment on the filter with compressed air.

Carburetors

Carburetor Installation

- Install the holder clamps as shown being careful of the screw position and the screw head direction.

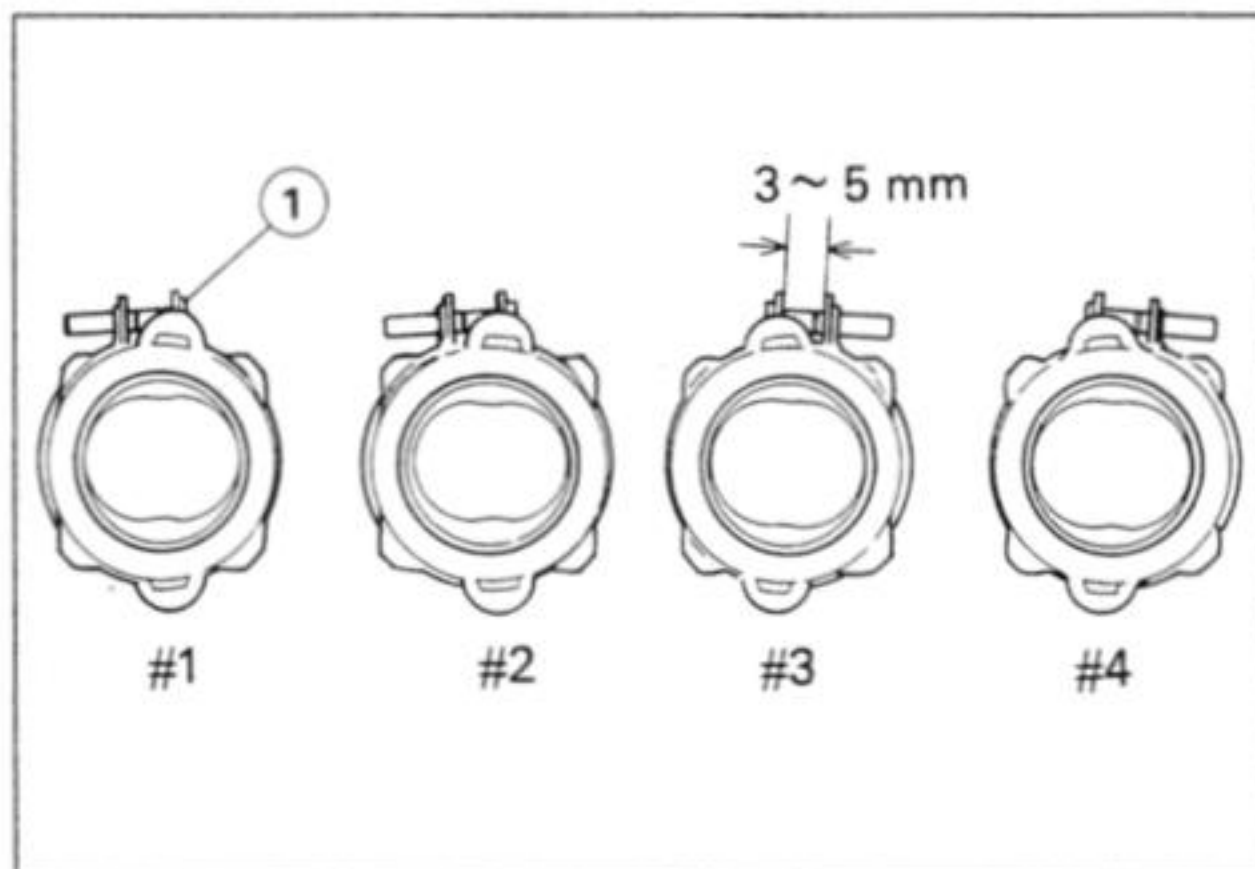

1. Screw Heads

- Turn the throttle grip and make sure that the throttle linkages do not contact the holder screws or hoses.

⚠ WARNING

Be sure to install the holder clamp screws in the direction shown. Or, the screws could come in contact with the throttle linkage resulting in an unsafe riding condition.

Coolant Filter Cleaning

(U.K. and L4 ~ L5 Models)

Before winter season starts, clean the coolant filter of carburetor system.

- Remove the lower fairings.
- Drain the coolant.
- Remove the coolant filter from the cooling hoses of carburetor system.

Cooling System

Table of Contents

Exploded View	3-2
Specifications	3-3
Special Tool	3-3
Sealant	3-3
Coolant	3-3
Coolant Filter Cleaning	3-3

3-2 COOLING SYSTEM

Exploded View

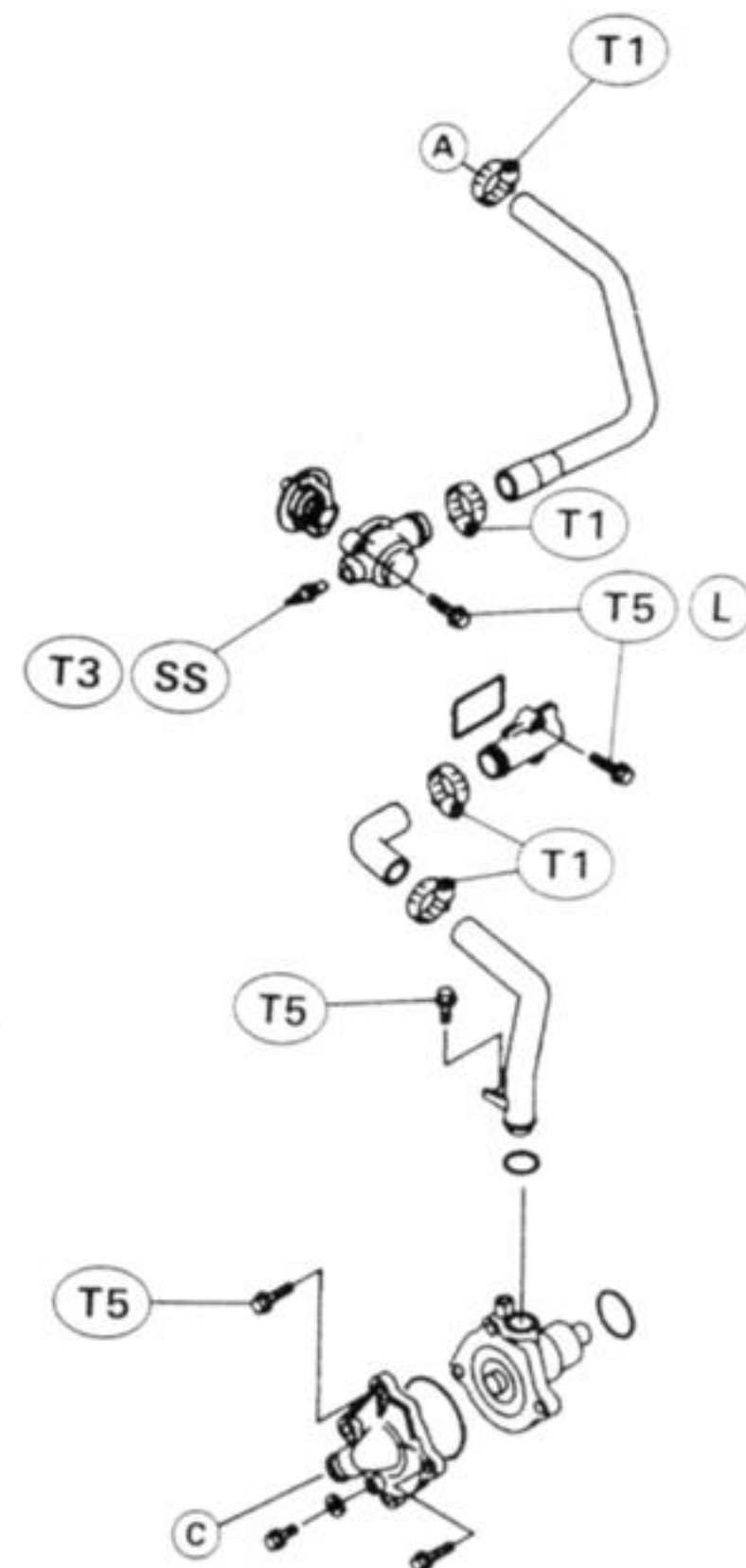
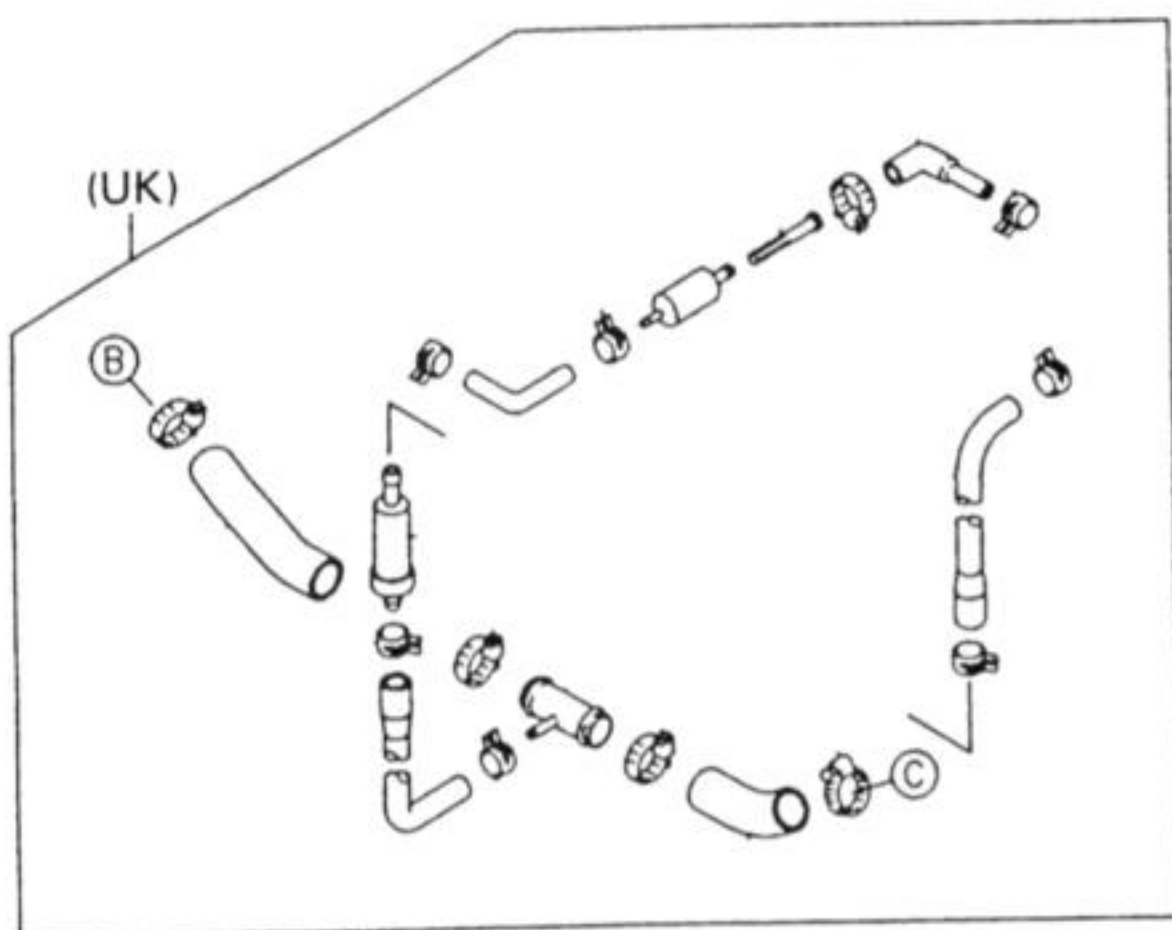
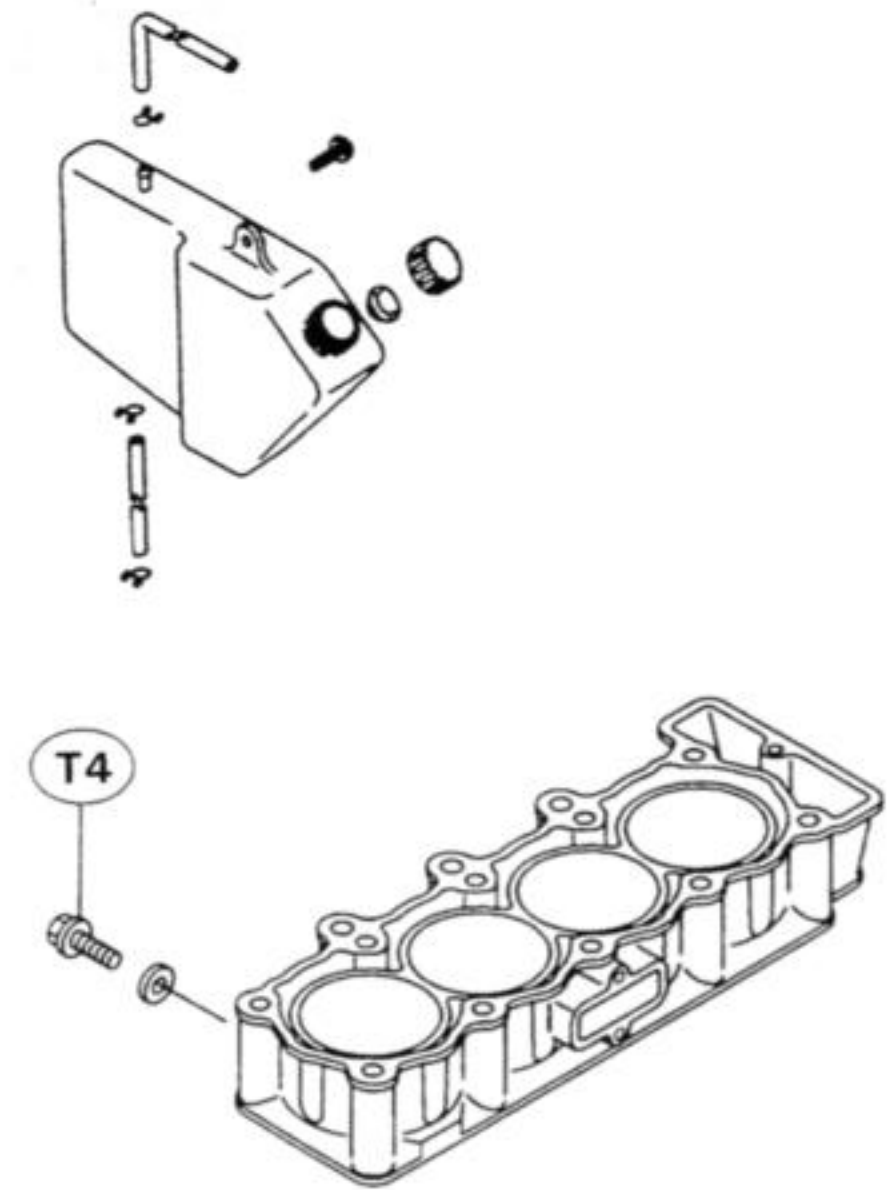
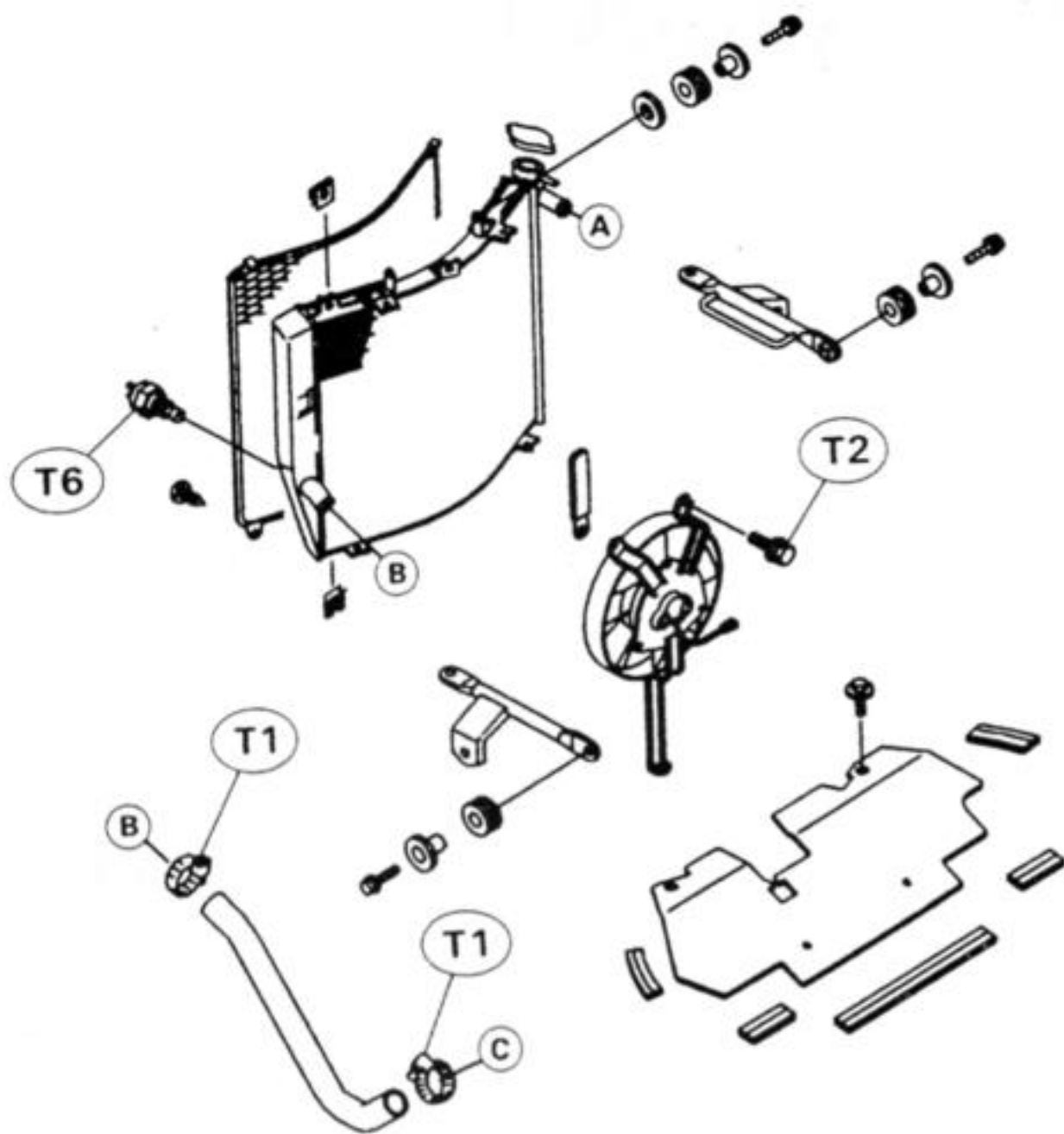

- T1 : 2.0 N-m (0.2 kg-m, 17 in-lb)
- T2 : 3.4 N-m (0.35 kg-m, 30 in-lb)
- T3 : 7.8 N-m (0.8 kg-m, 69 in-lb)
- T4 : 8.8 N-m (0.9 kg-m, 78 in-lb)
- T5 : 9.8 N-m (1.0 kg-m, 7.0 ft-lb)
- T6 : 18 N-m (1.8 kg-m, 13 ft-lb)

L : Apply a non-permanent locking agent to the threads.

SS: Apply silicone sealant to the threads.

UK: U.K. and L4 ~ L5 Models

Specifications

Item	Standard
Coolant: Type Color Mixed ratio Freezing point Total amount	Permanent type of antifreeze for aluminum engines and radiators Green Soft water 50%, coolant 50% -35°C (-31°F) 2.3 L (reservoir tank full level)
Radiator: Cap relief pressure	93 ~ 123 kPa (0.95 ~ 1.25 kg/cm ² , 14 ~ 18 psi)
Thermostat: Valve opening temperature Valve full opening lift	80.0 ~ 84.0°C (176 ~ 183°F) Not less than 6 mm @95°C (203°F)

Special Tool

Socket Wrench, Hex 8: 57001-1268

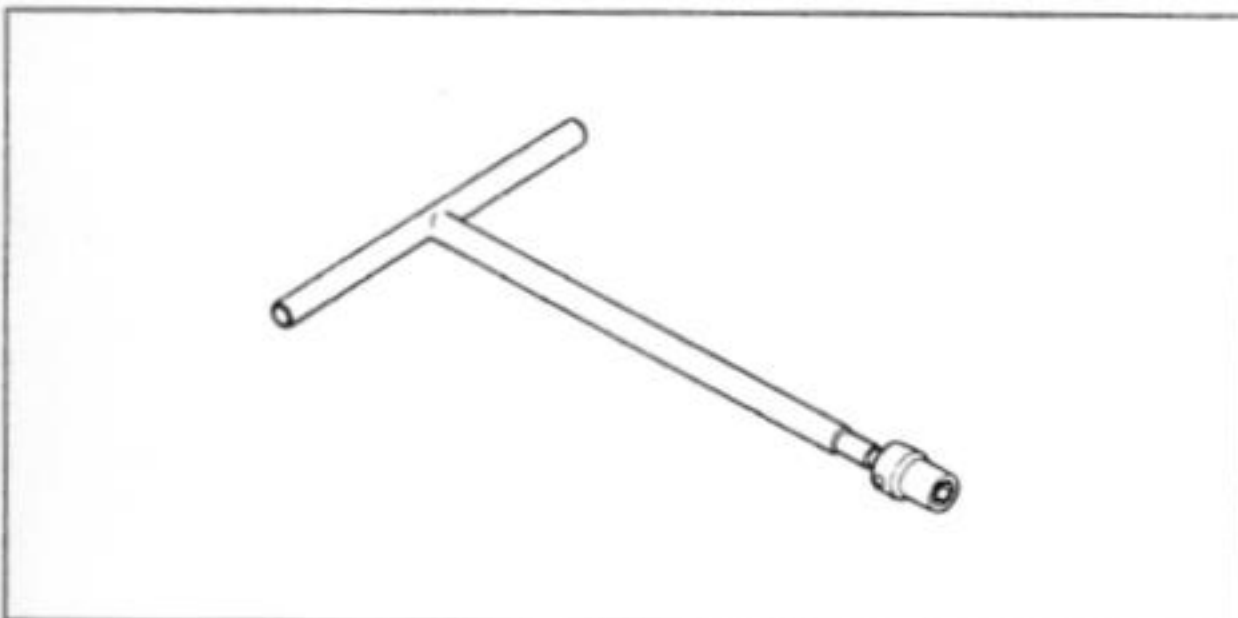

Sealant

Kawasaki Bond (Silicone Sealant): 56019-120

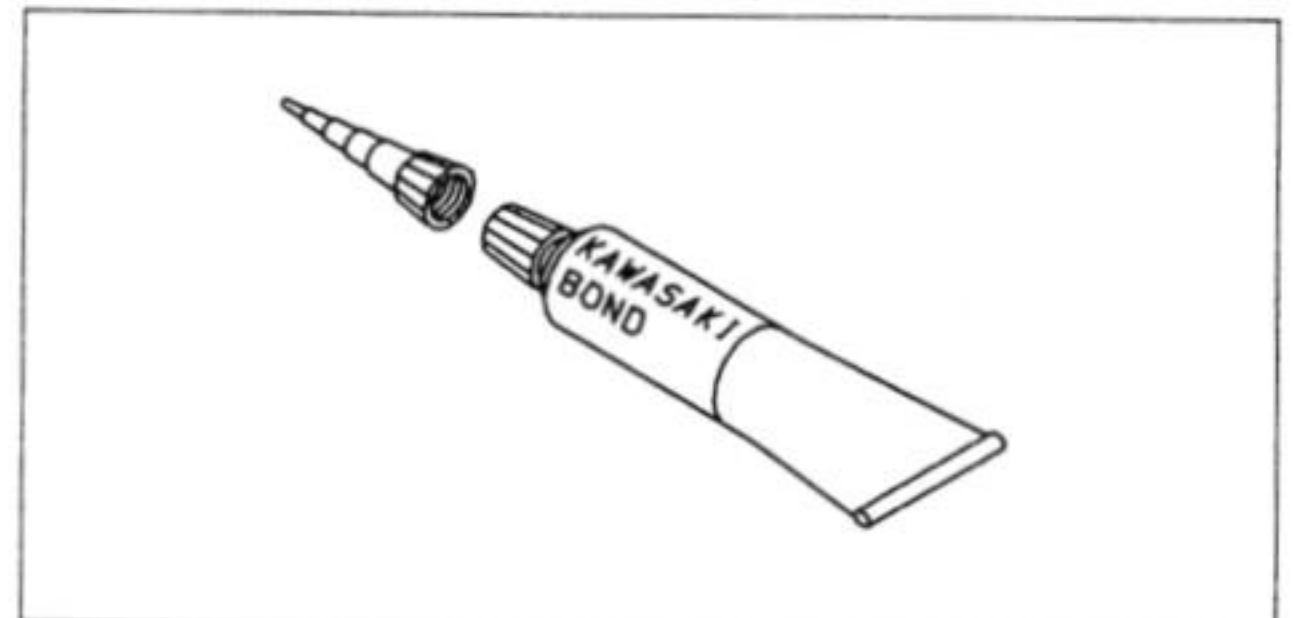

Coolant

Coolant Filter cleaning

Refer to the chapter of carburetor in Fuel System for the cleaning Procedure.

Engine Top End

Table of Contents

Exploded View4-2
Specifications4-4
Special Tools4-6
Sealant.....4-7

4-2 ENGINE TOP END

Exploded View

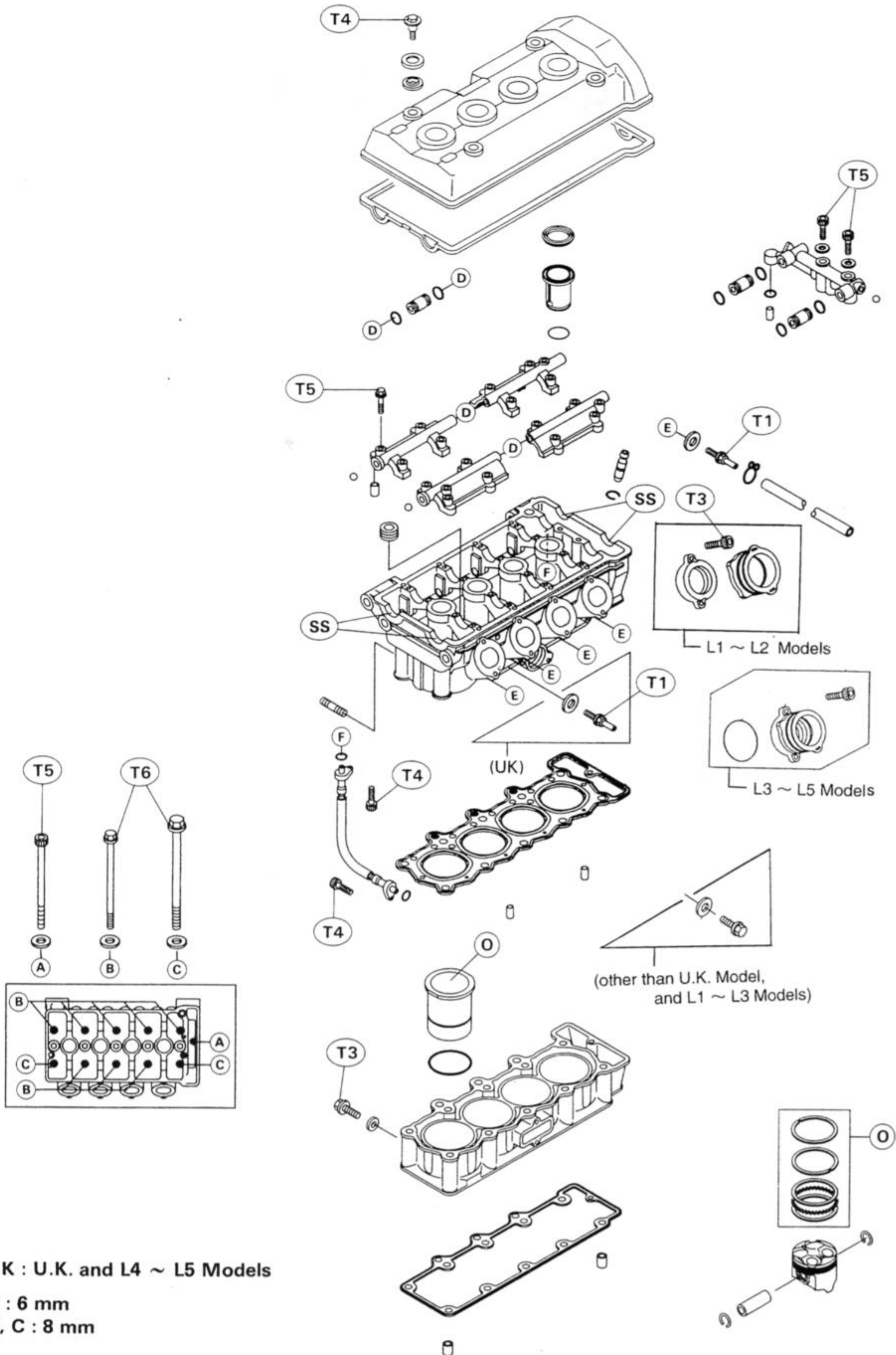

UK : U.K. and L4 ~ L5 Models

A : 6 mm

B, C : 8 mm

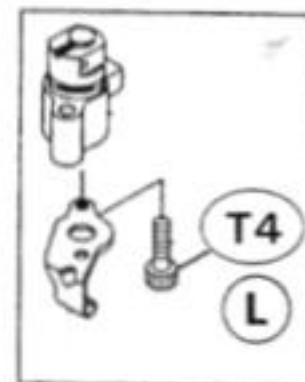
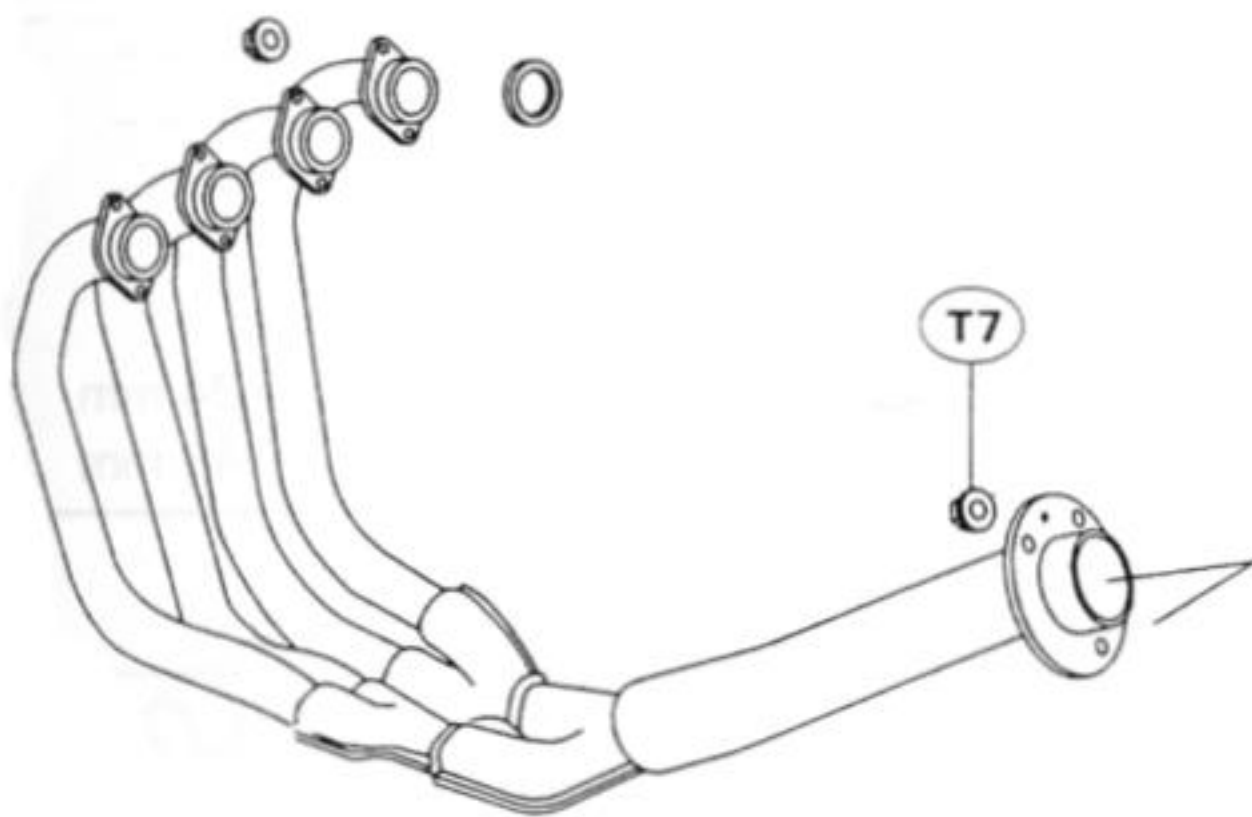
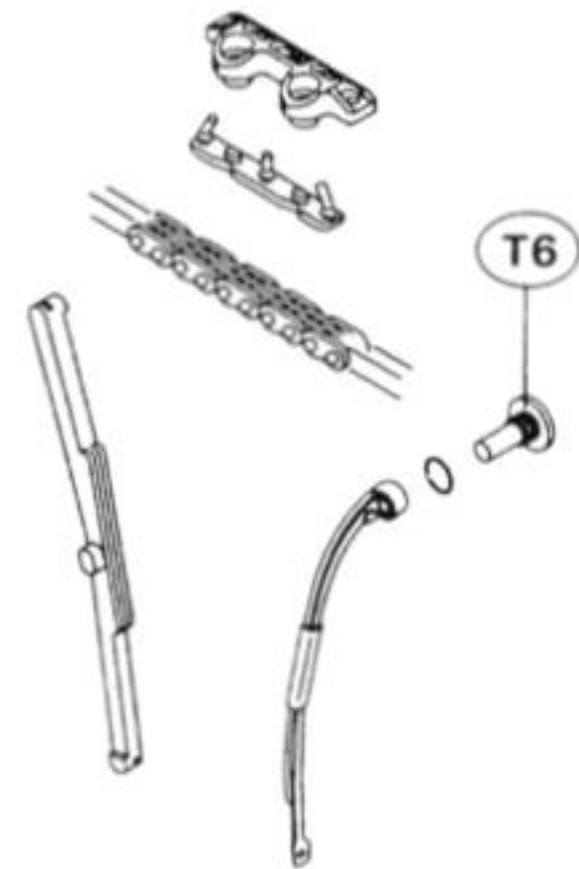
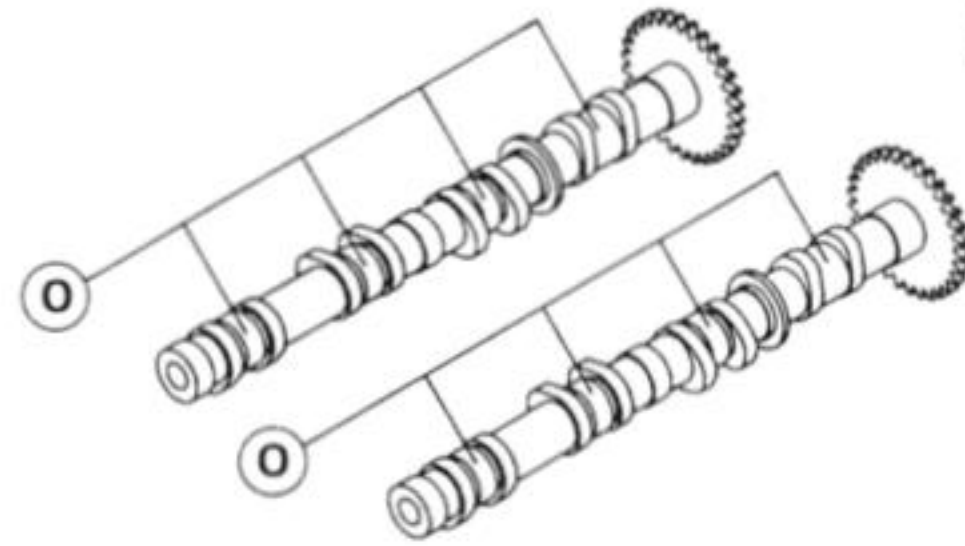
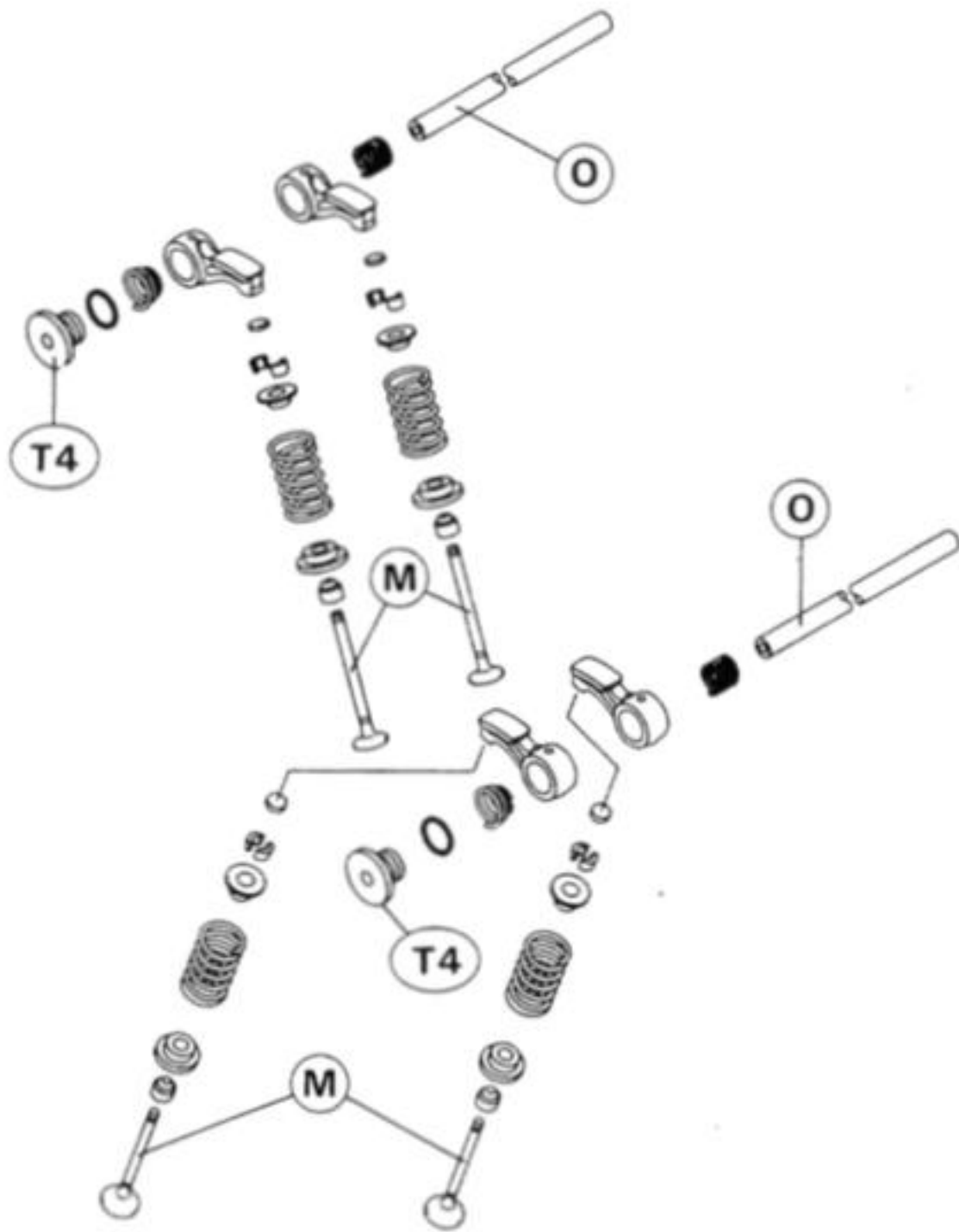

L3 ~ L5 Models

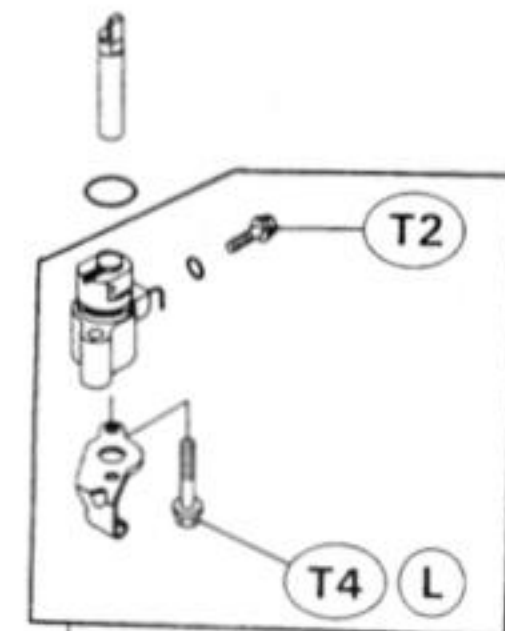

L1 ~ L2 Models

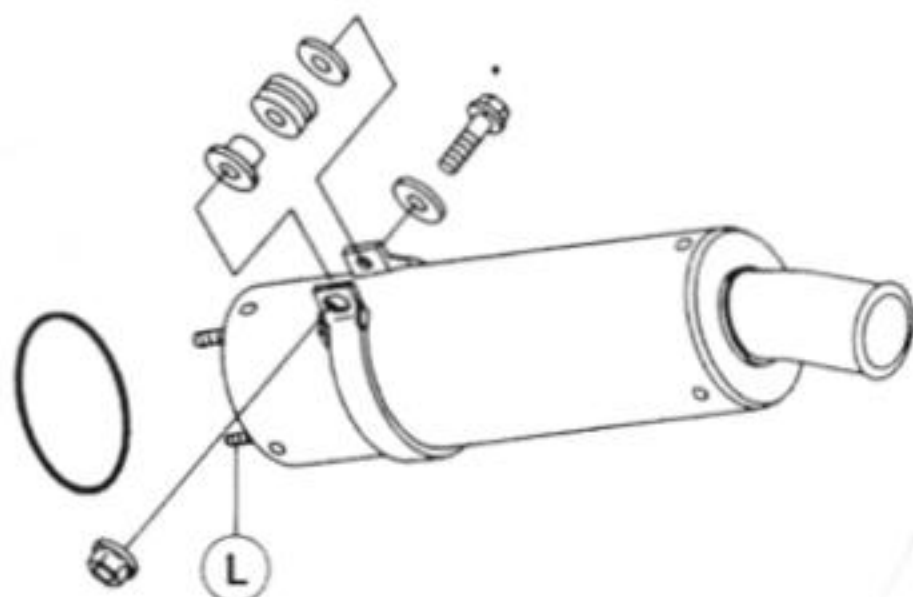

- T1 : 4.9 N-m (0.5 kg-m, 43 in-lb)
- T2 : 5.9 N-m (0.6 kg-m, 52 in-lb)
- T3 : 8.8 N-m (0.9 kg-m, 78 in-lb)
- T4 : 9.8 N-m (1.0 kg-m, 7.0 ft-lb)
- T5 : 12 N-m (1.2 kg-m, 8.5 ft-lb)
- T6 : 25 N-m (2.5 kg-m, 18 ft-lb)
- T7 : 27 N-m (2.8 kg-m, 20 ft-lb)

- L : Apply a non-permanent locking agent to the threads.
- M : Apply molybdenum disulfide grease.
- SS: Apply silicone sealant to the threads.
- O : Apply oil.

4-4 ENGINE TOP END

Specifications

Item	Standard	Service Limit
Camshaft:		
Cam height:	Inlet 31.778 ~ 31.918 mm Exhaust 31.469 ~ 31.609 mm	31.68 mm 31.37 mm
Camshaft, camshaft cap clearance:	A 0.028 ~ 0.071 mm B 0.078 ~ 0.121 mm	0.16 mm 0.21 mm
Camshaft journal diameter:	A 23.950 ~ 23.972 mm B 23.900 ~ 23.922 mm	23.92 mm 23.87 mm
Camshaft bearing inside diameter	24.000 ~ 24.021 mm	24.08 mm
Camshaft runout	---	0.1 mm TIR
Camshaft chain 20-link length	127.0 ~ 127.4 mm	128.9 mm
Cylinder Head:		
Cylinder compression (Usable range)	686 ~ 1 079 kPa (7.0 ~ 11.0 kg/cm ² , 99 ~ 156 psi) @330 r/min (rpm)	
Cylinder head warp	---	0.05 mm
Valves:		
Valve clearance:	Inlet 0.12 ~ 0.17 mm Exhaust 0.16 ~ 0.21 mm	--- ---
Valve spring free length	38.2 mm	36.4 mm
Valve head thickness:	Inlet 0.5 mm Exhaust 0.7 mm	0.25 mm 0.35 mm
Valve stem bend	0.02 mm TIR or under	0.05 mm TIR
Valve seat cutting angle	45°, 32°, 60°	---
Valve seating surface:		
Width:	Inlet 0.5 ~ 1.0 mm Exhaust 0.5 ~ 1.0 mm	--- ---
Outside diameter:	Inlet 21.5 ~ 21.7 mm Exhaust 18.5 ~ 18.7 mm	--- ---
Valve/valve guide clearance (wobble method):	Inlet 0.031 ~ 0.140 mm Exhaust 0.085 ~ 0.180 mm	0.34 mm 0.41 mm

Camshaft Height Measurement

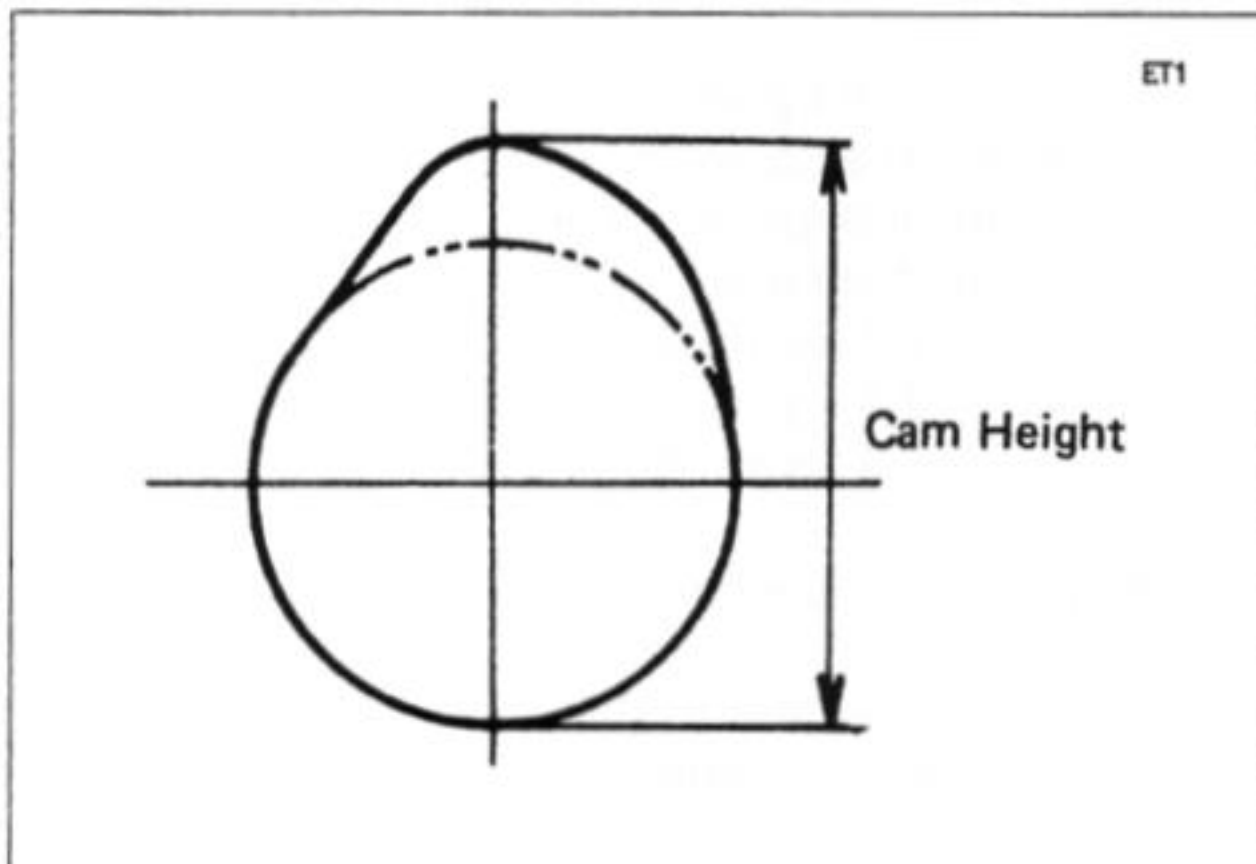

Camshaft Journal Diameter

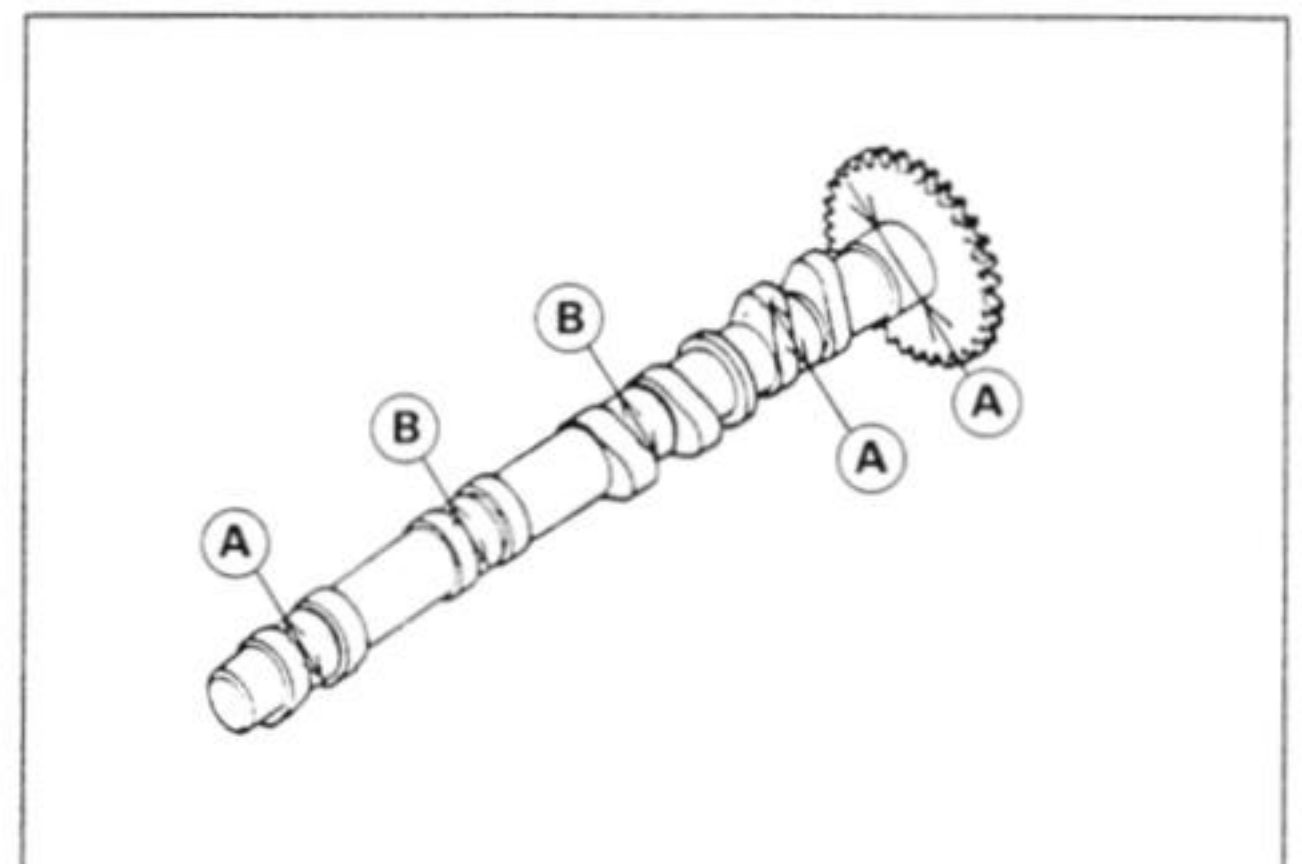

Item		Standard	Service Limit
Valve stem diameter:	Inlet	3.975 ~ 3.990 mm	3.96 mm
	Exhaust	3.955 ~ 3.970 mm	3.94 mm
Valve guide inside diameter		4.000 ~ 4.012 mm	4.08 mm
Cylinder, Piston:			
Cylinder inside diameter		57.000 ~ 57.012 mm	57.10 mm
Piston diameter		56.942 ~ 56.957 mm	56.79 mm
Piston/cylinder clearance		0.043 ~ 0.070 mm	- - -
Oversize piston and rings		+ 0.5 mm	- - -
Piston ring/groove clearance		0.030 ~ 0.070 mm	0.17 mm
Piston ring end gap:	Top	0.15 ~ 0.30 mm	0.6 mm
	Second	0.35 ~ 0.50 mm	0.8 mm

Valve Head

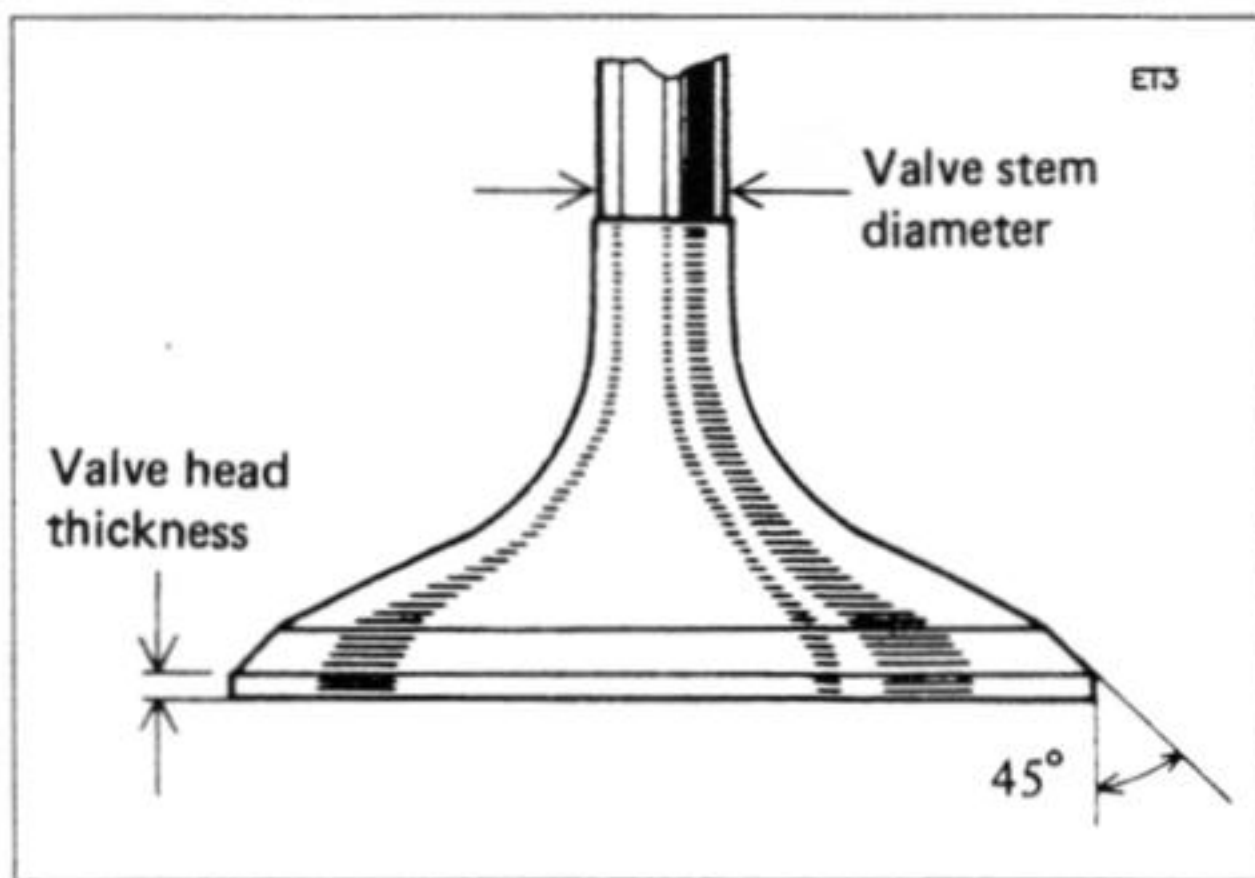

Valve Stem Bend

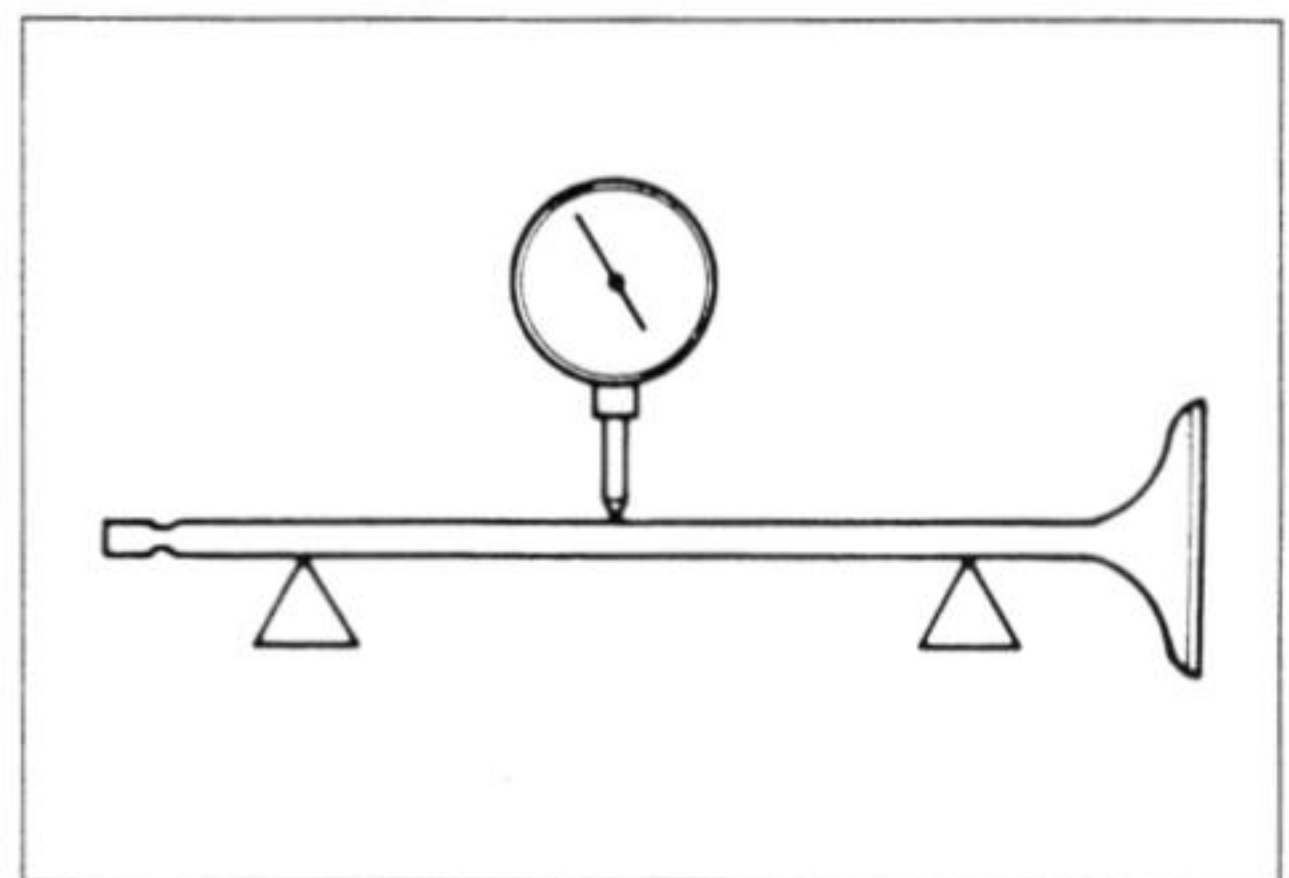

Camshaft Runout

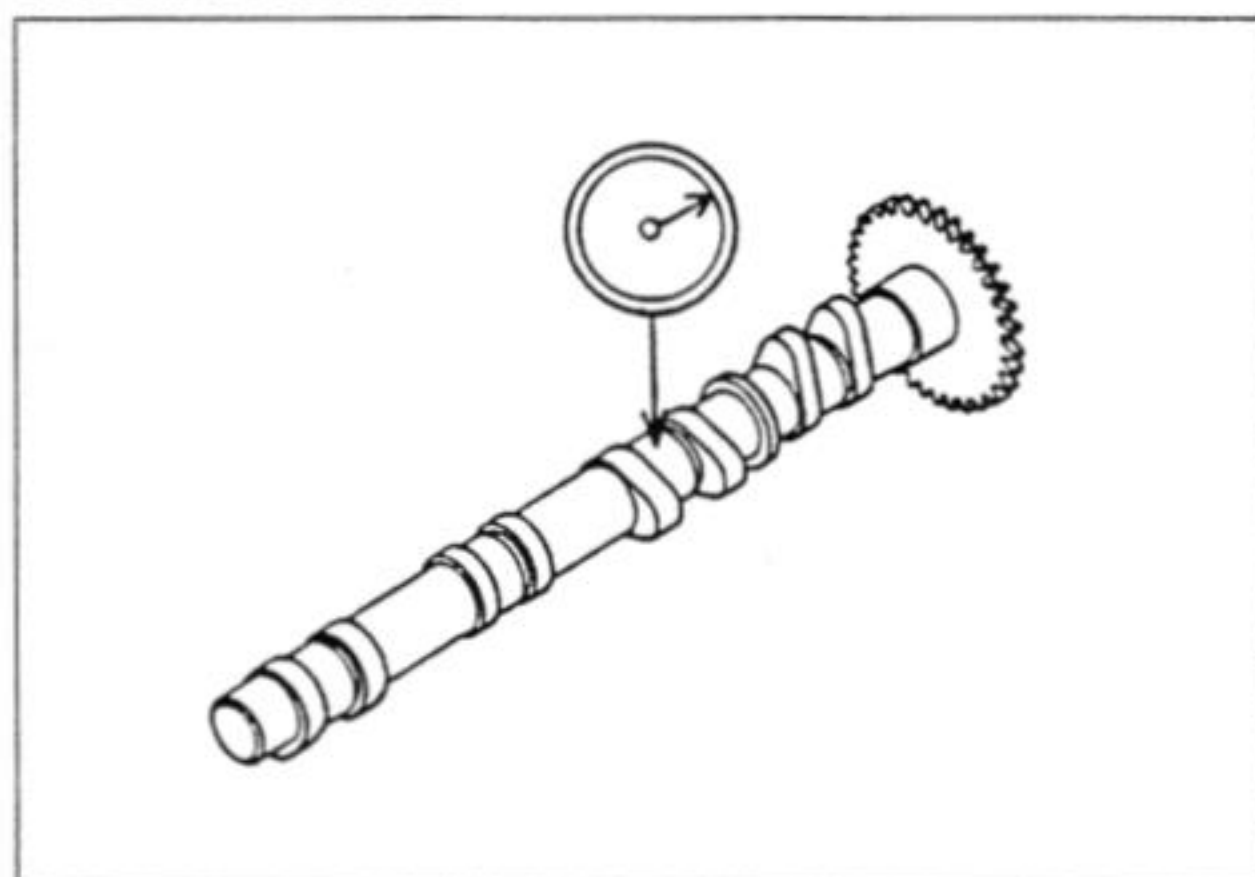

4-6 ENGINE TOP END

Special Tools

Compression Gauge: 57001-221



Valve Spring Compressor Joint: 57001-1271

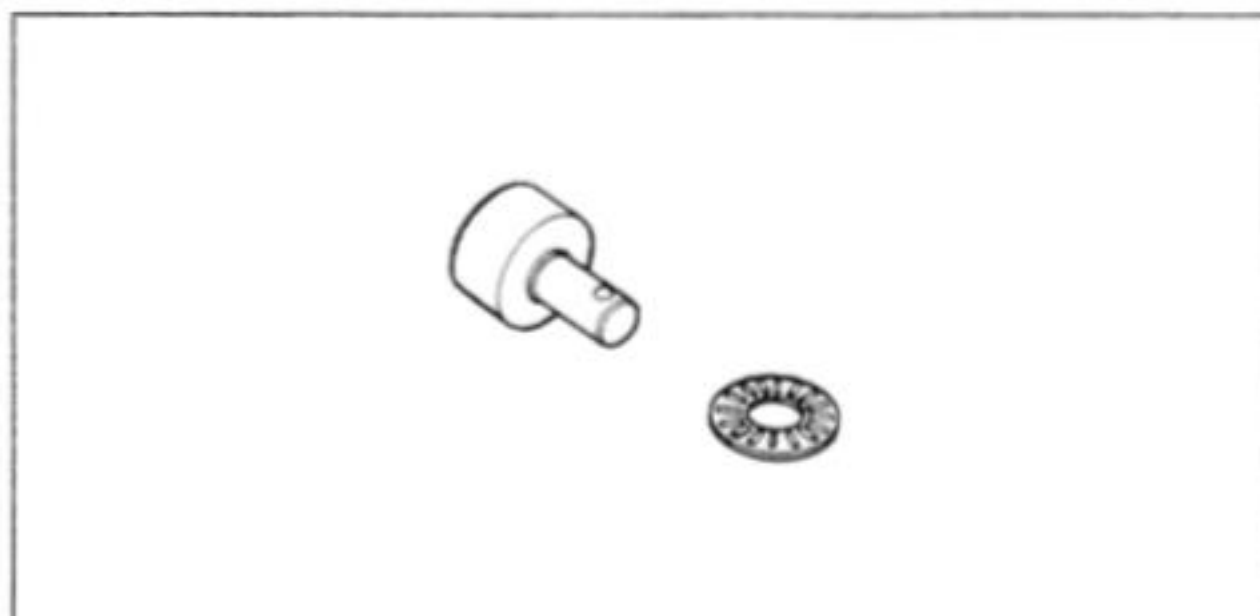

Compression Gauge Adapter, M10 X 1.0: 57001-1317

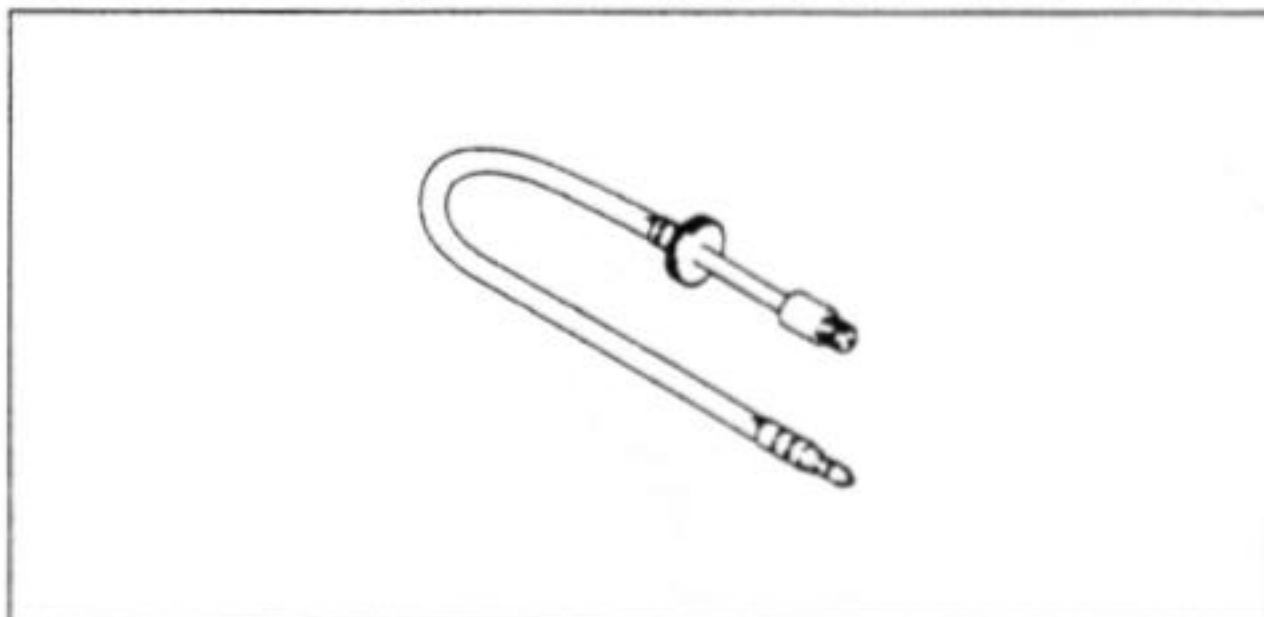

Valve Guide Arbor, $\Phi 4$: 57001-1273



Rocker Arm Holder: 57001-1270

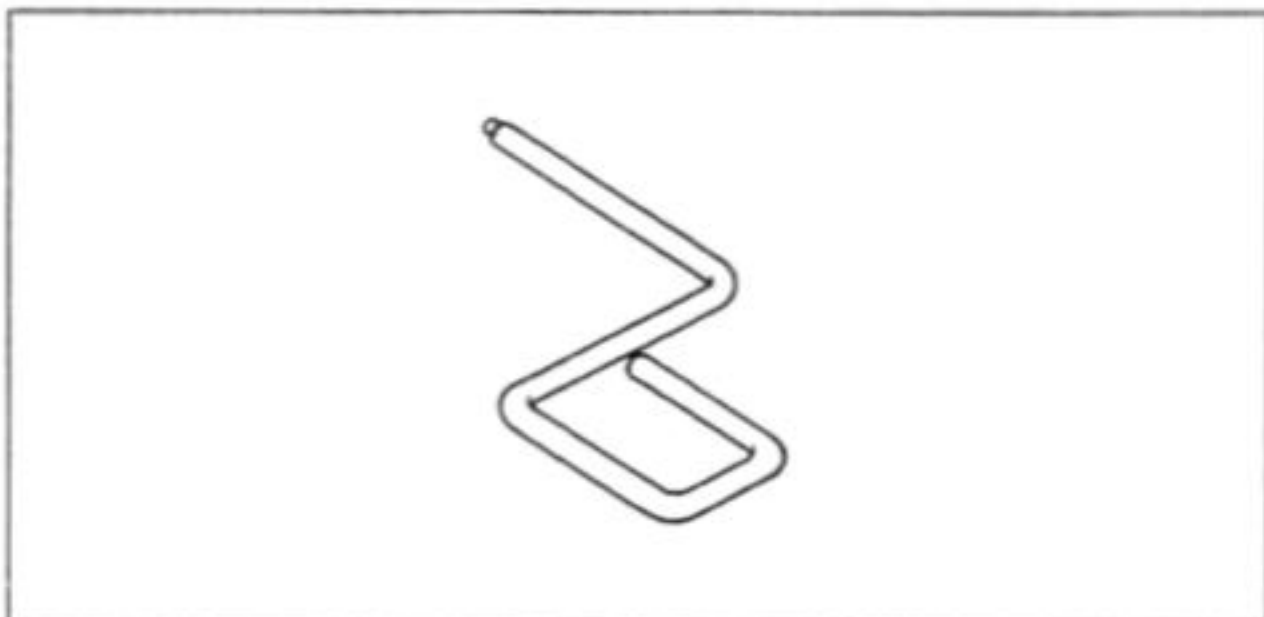

Valve Guide Reamer, $\Phi 4$: 57001-1274



Valve Spring Compressor Assembly: 57001-241

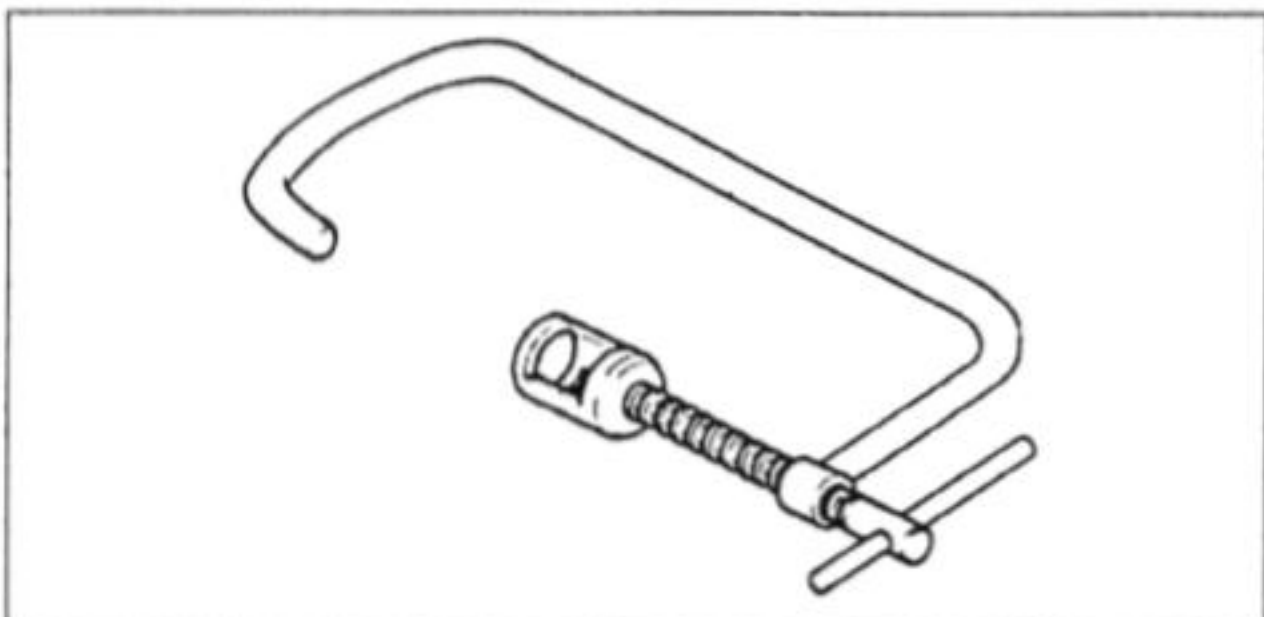

Valve Seat Cutter Holder, $\Phi 4$: 57001-1275

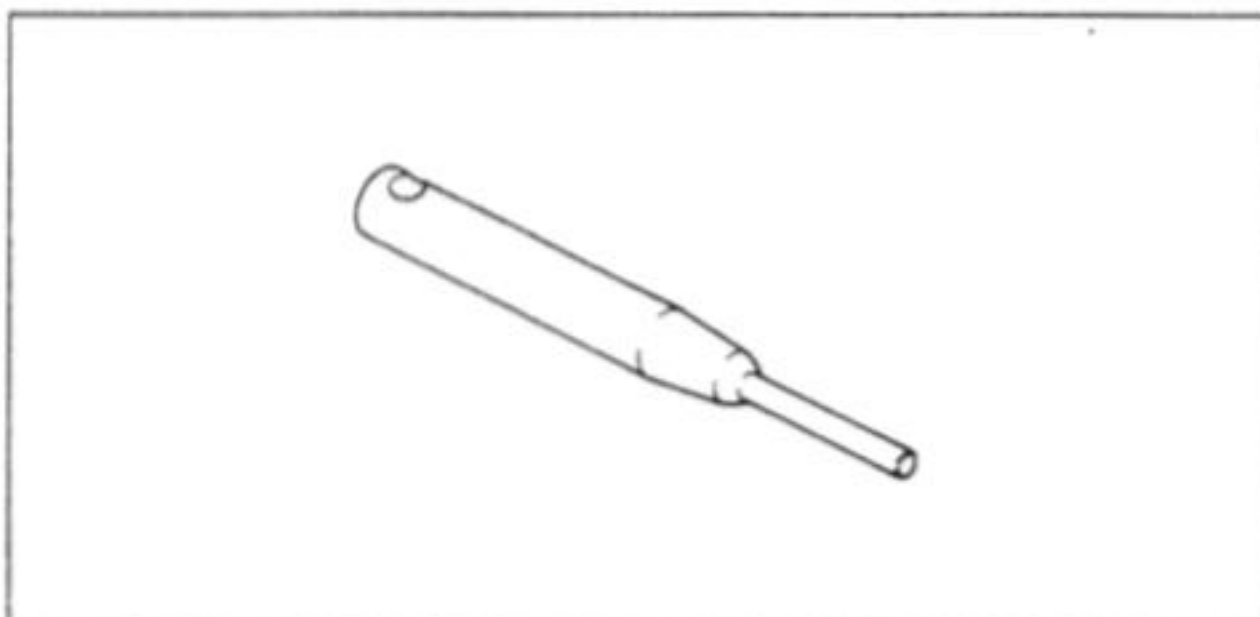

Valve Spring Compressor Adapter, $\Phi 21$: 57001-1272

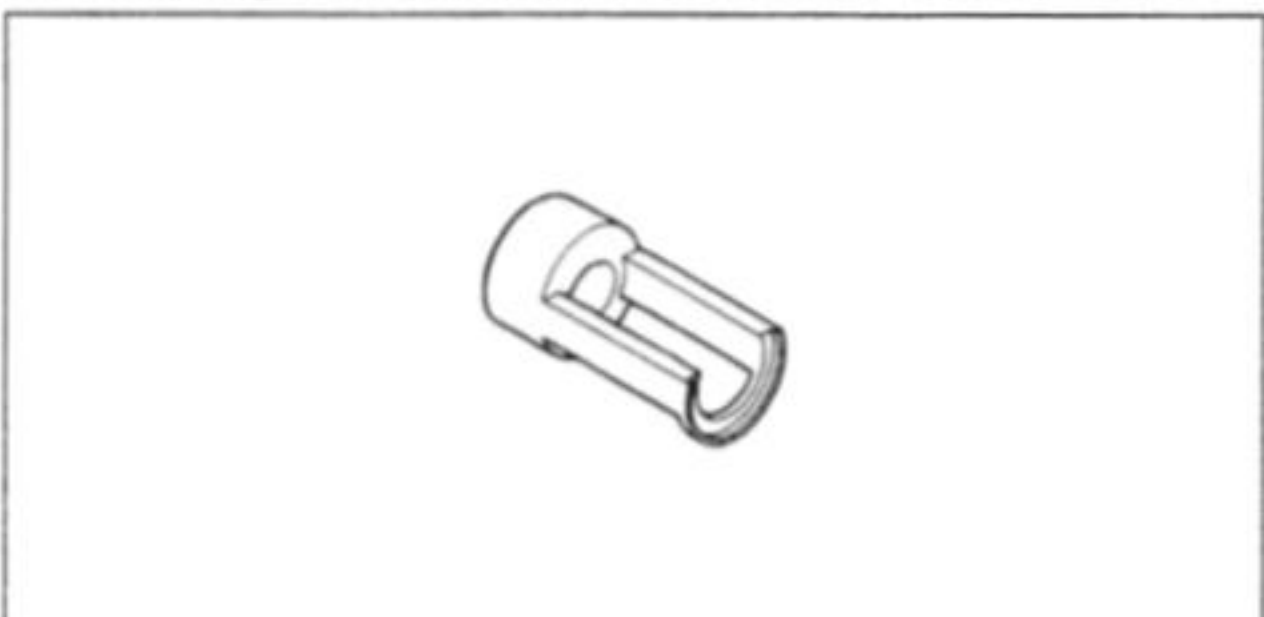

Valve Seat Cutter, $45^\circ - \Phi 20.5$: 57001-1307



Valve Seat Cutter, 30° - ϕ 18: 57001-1308

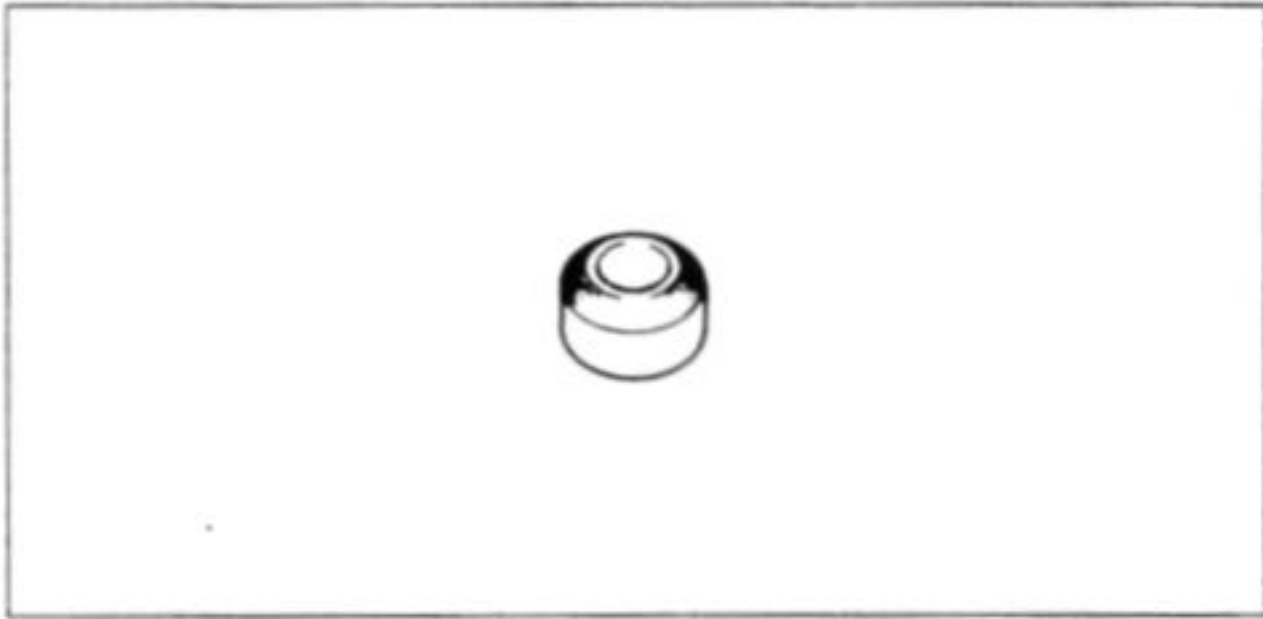

Valve Seat Cutter, 65° - ϕ 19: 57001-1310

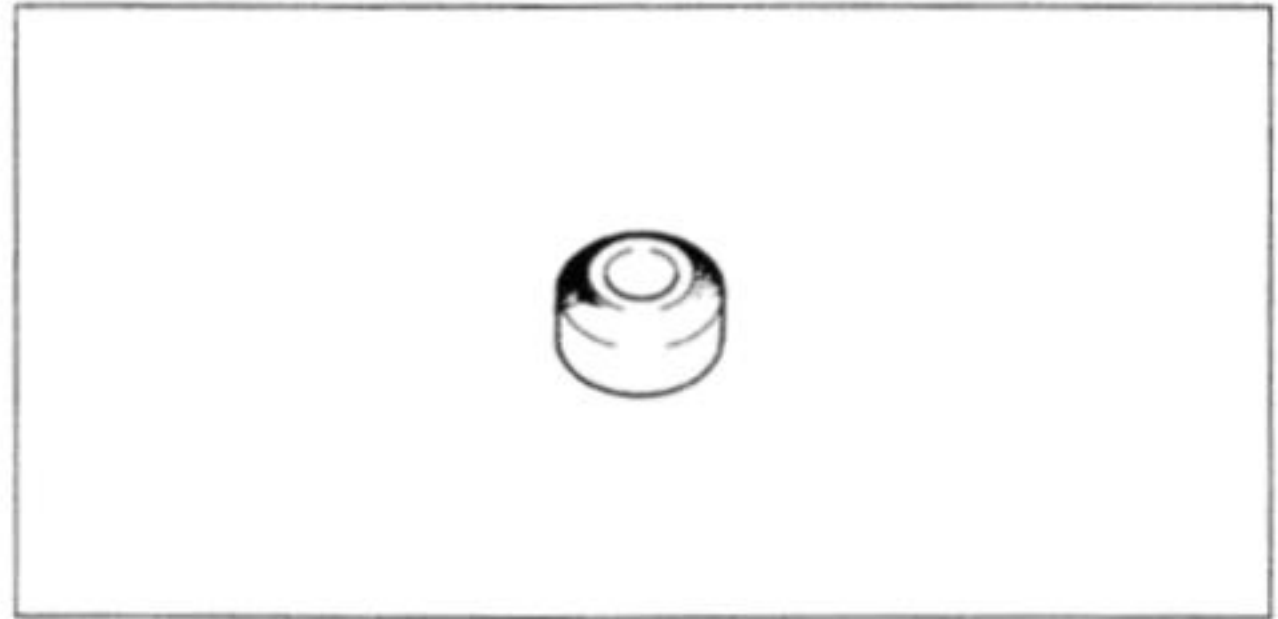

Valve Seat Cutter Holder Bar: 57001-1128

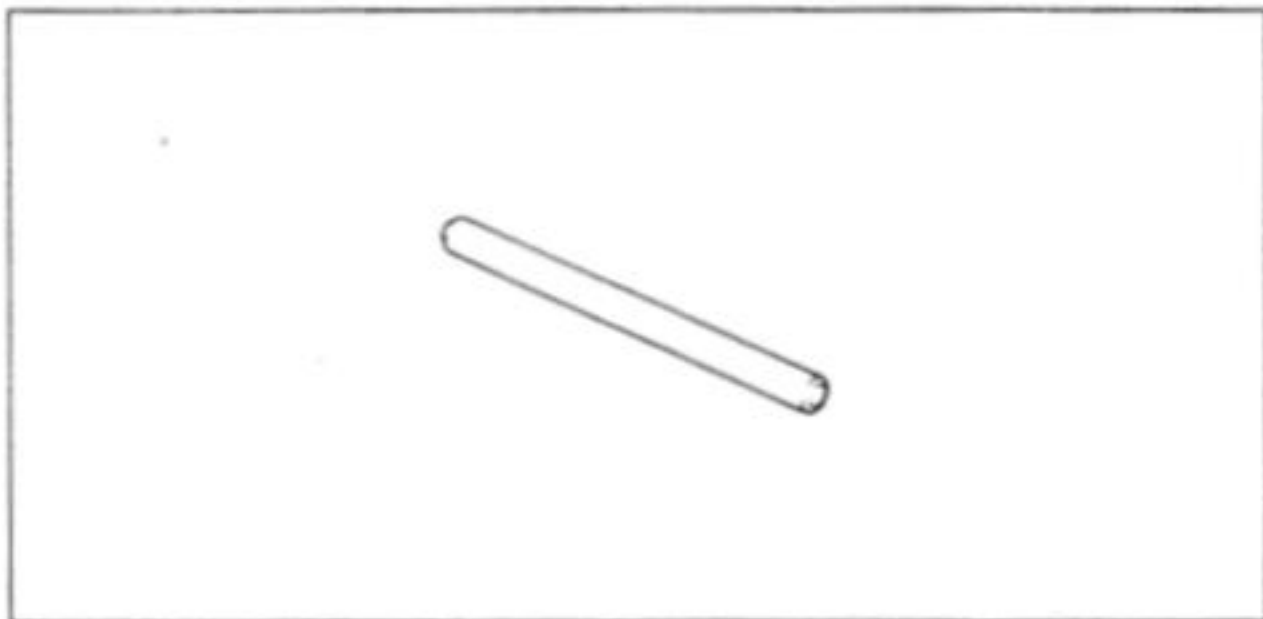

Piston Base, ϕ 8: 57001-147

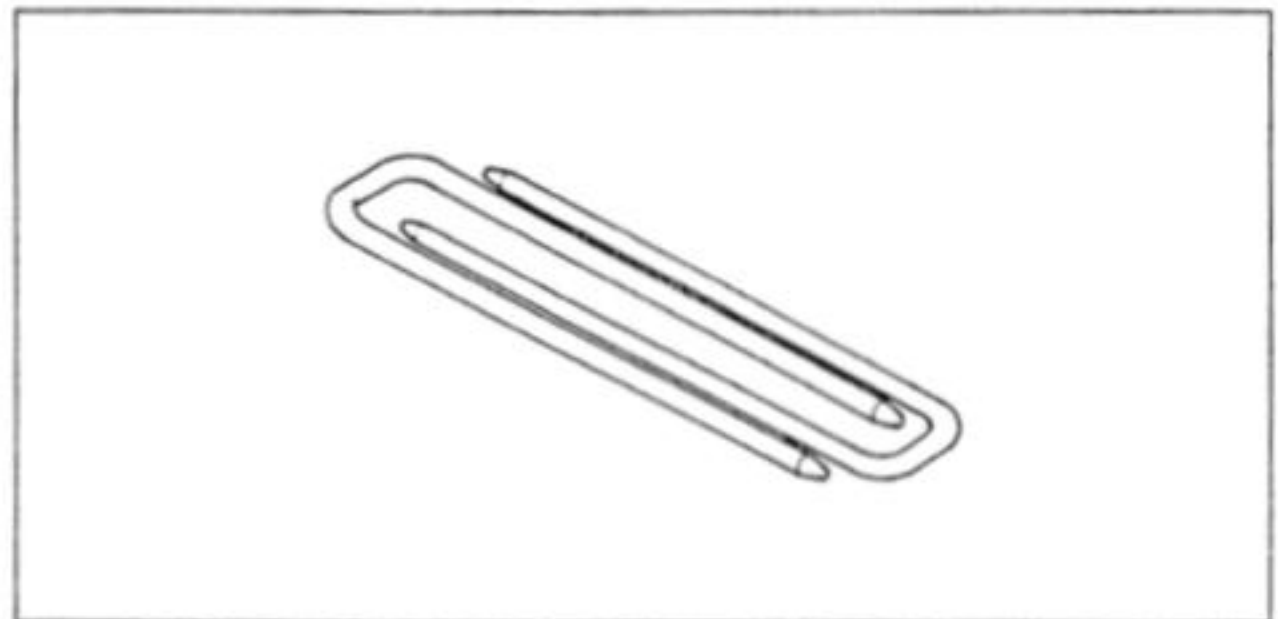

Valve Seat Cutter, 60° - ϕ 25: 57001-1328

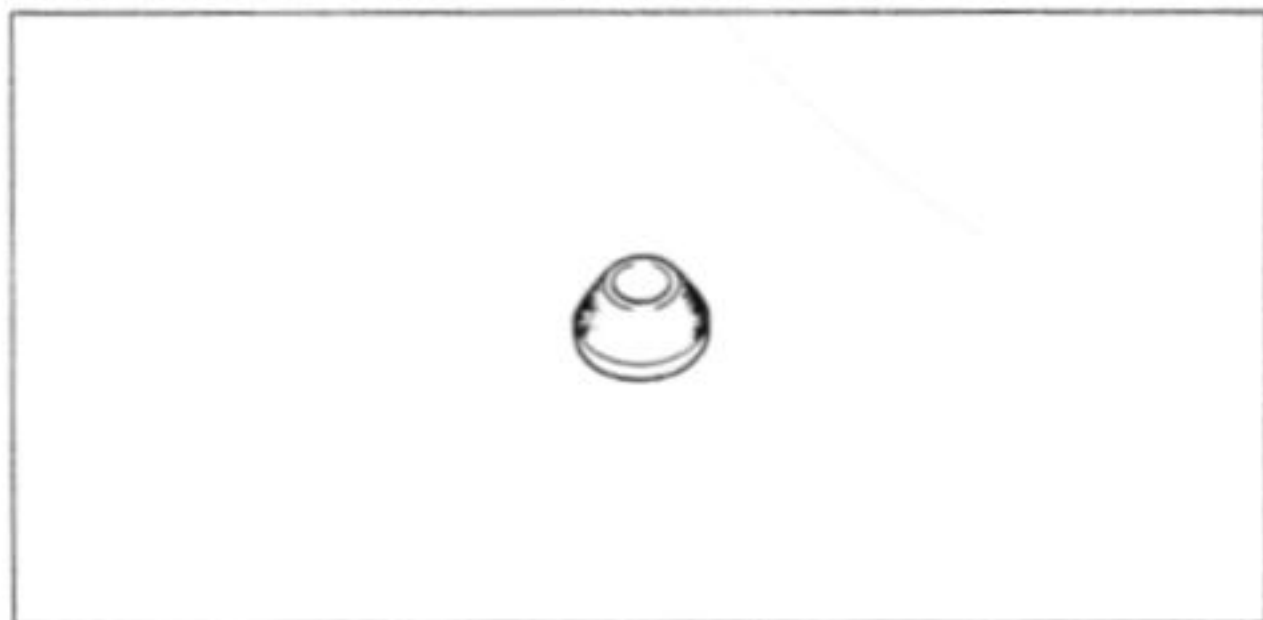

Piston Pin Puller Assembly: 57001-910

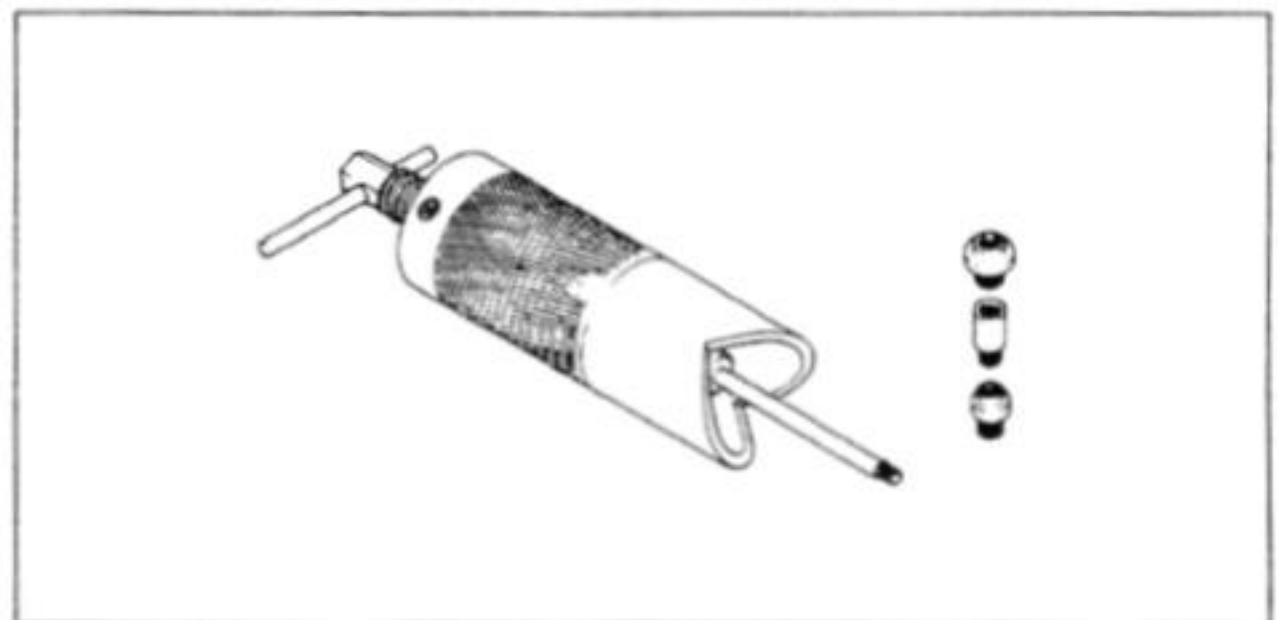

Valve Seat Cutter, 45° - ϕ 22: 57001-1205

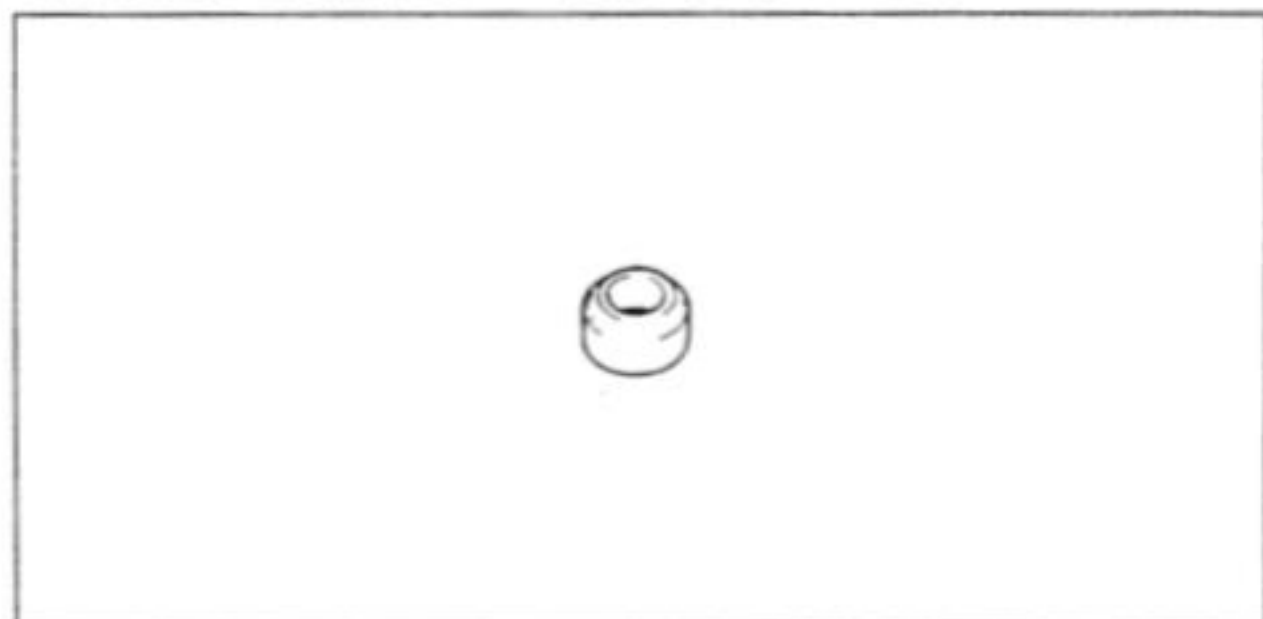

Sealant

Valve Seat Cutter, 32° - ϕ 22: 57001-1206

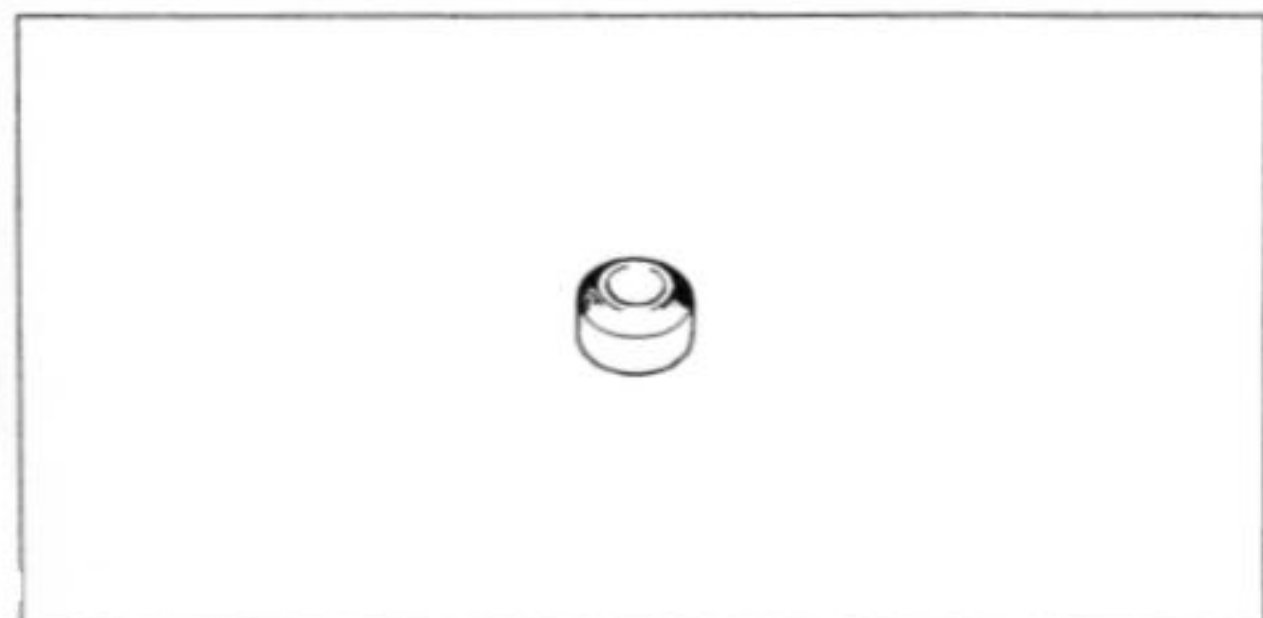

Kawasaki Bond (Silicone Sealant): 56019-120

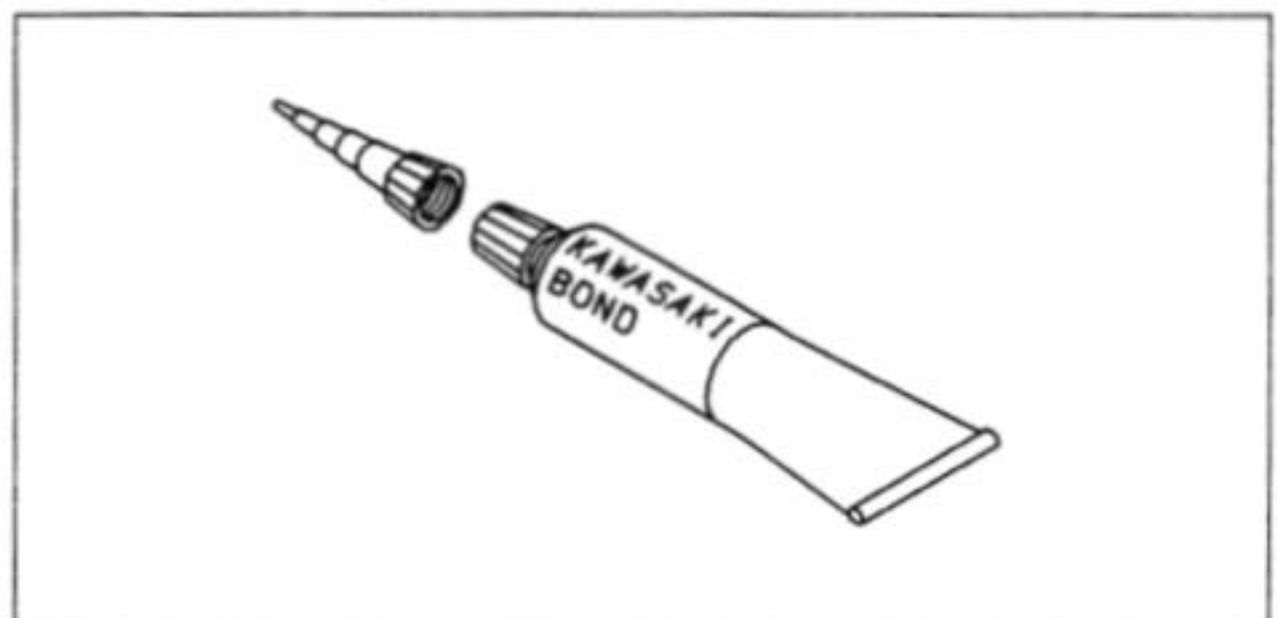

Clutch

Table of Contents

Exploded View	5-2
Specifications	5-3
Special Tool.....	5-3
Sealant.....	5-3

5-2 CLUTCH

Exploded View

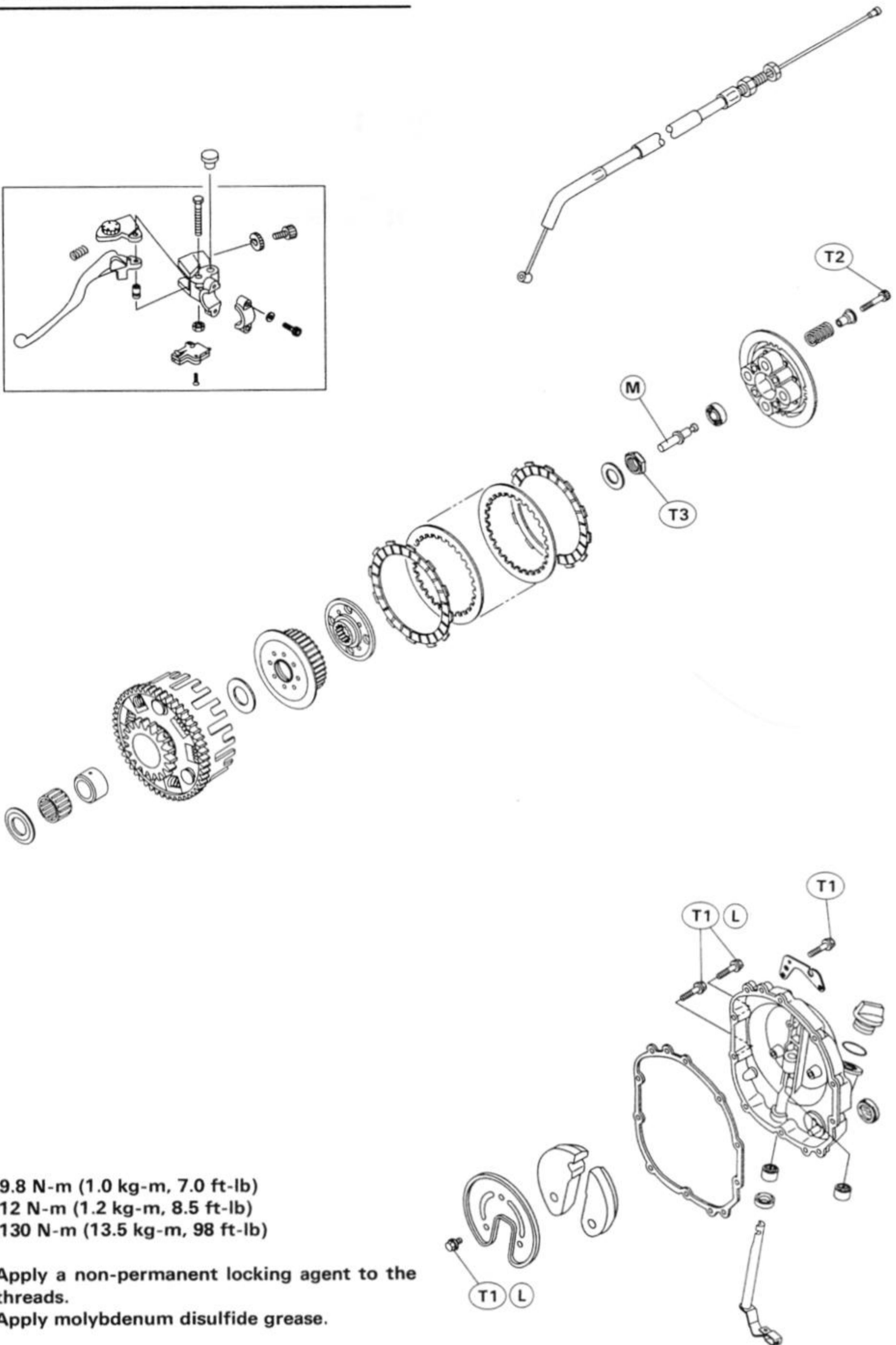

Specifications

Item	Standard	Service Limit
Clutch: Clutch lever free play Friction plate thickness Friction and steel plate warp Clutch spring free length	2 ~ 3 mm 2.72 ~ 2.88 mm 0.15 mm or under 39.5 mm	- - - 2.5 mm 0.3 mm 38.1 mm

Special Tool

Clutch Holder: 57001-1243

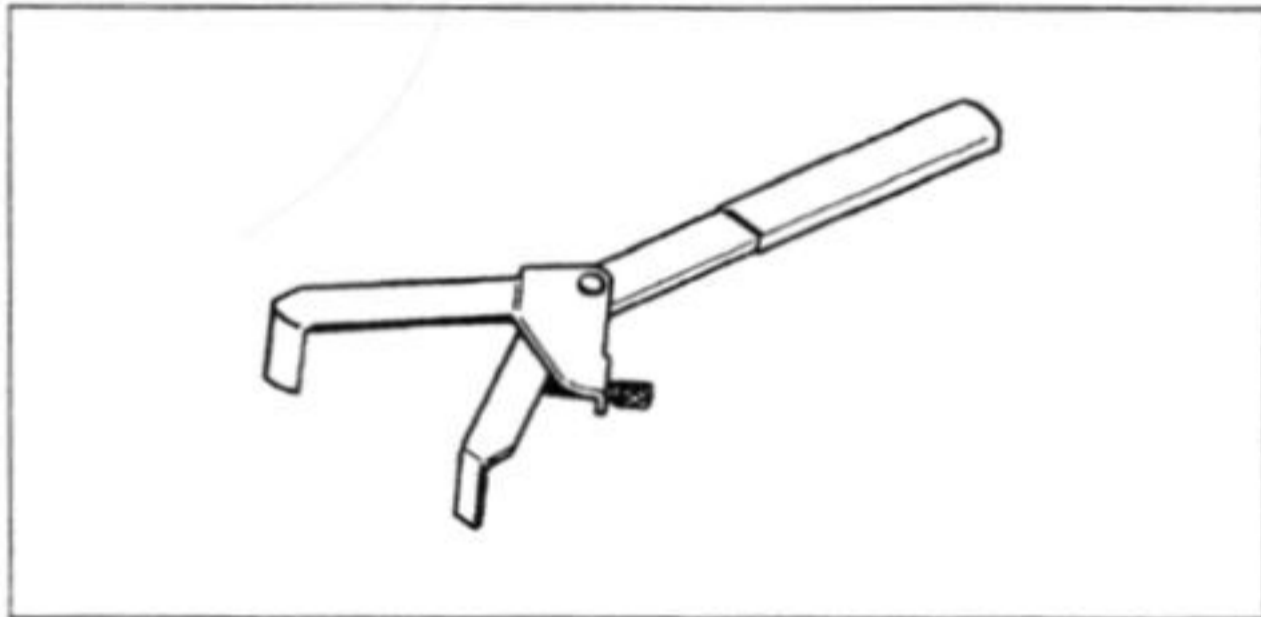

Sealant

Kawasaki Bond (Silicone Sealant): 56019-120

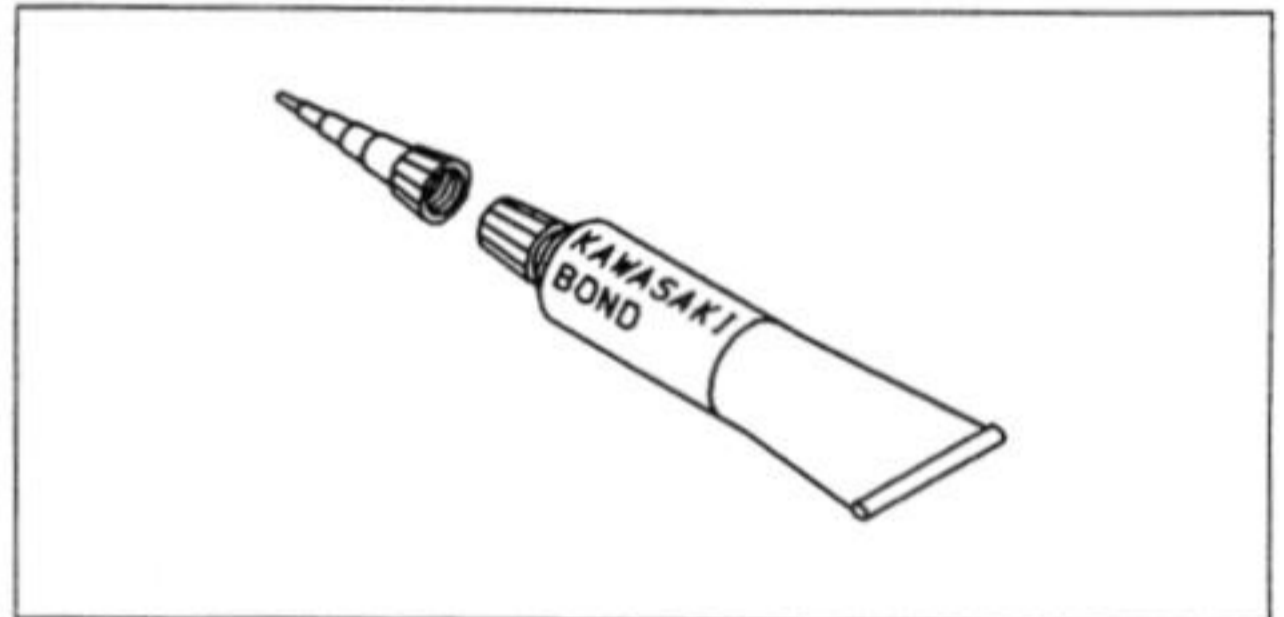

Engine Lubrication System

Table of Contents

Exploded View	6-2
Engine Oil Flow Chart.....	6-4
Specifications	6-6
Special Tools	6-6
Sealant.....	6-6

6-2 ENGINE LUBRICATION SYSTEM

Exploded View

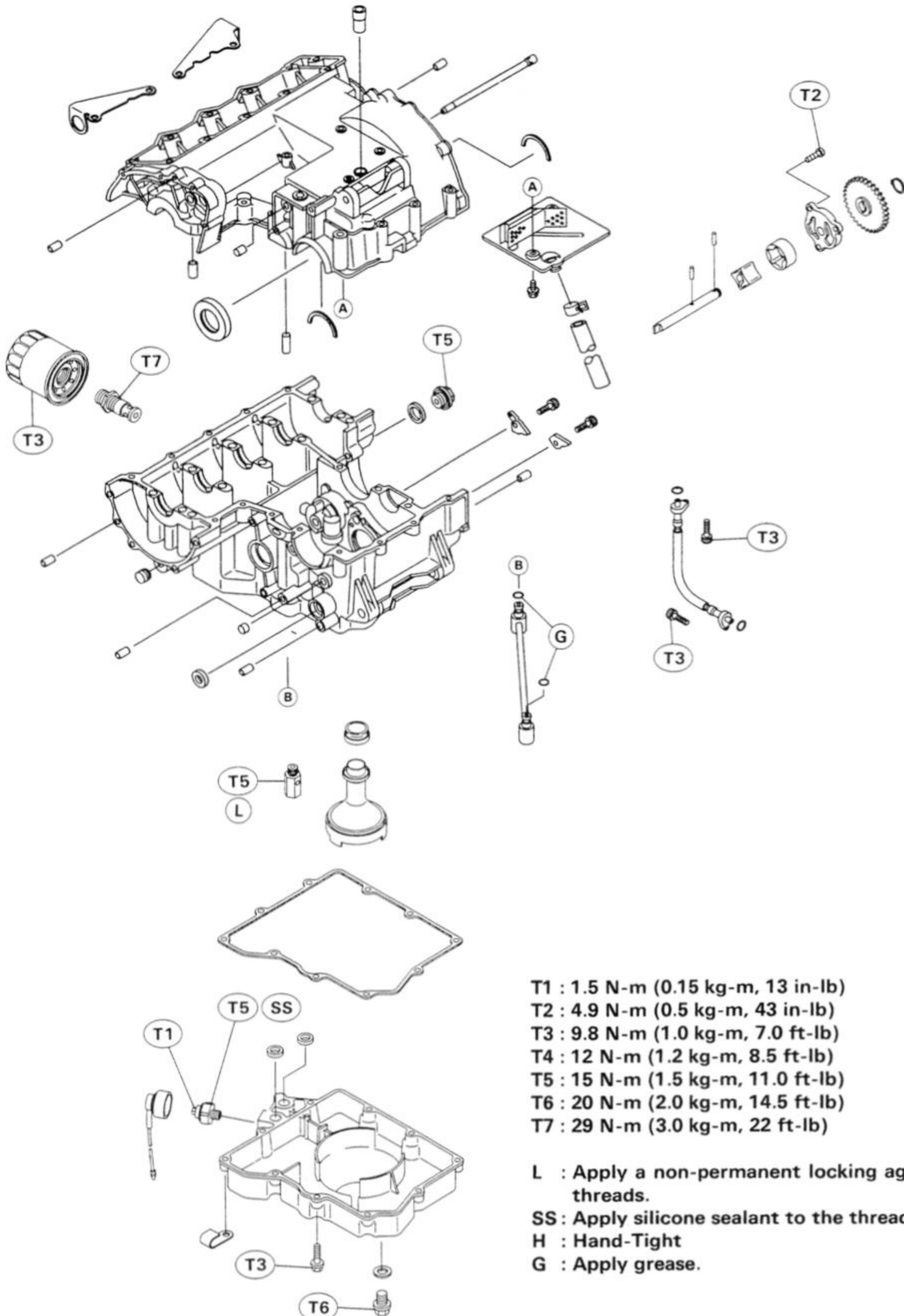

- T1 : 1.5 N-m (0.15 kg-m, 13 in-lb)
- T2 : 4.9 N-m (0.5 kg-m, 43 in-lb)
- T3 : 9.8 N-m (1.0 kg-m, 7.0 ft-lb)
- T4 : 12 N-m (1.2 kg-m, 8.5 ft-lb)
- T5 : 15 N-m (1.5 kg-m, 11.0 ft-lb)
- T6 : 20 N-m (2.0 kg-m, 14.5 ft-lb)
- T7 : 29 N-m (3.0 kg-m, 22 ft-lb)

- L : Apply a non-permanent locking agent to the threads.
- SS: Apply silicone sealant to the threads.
- H : Hand-Tight
- G : Apply grease.

ENGINE LUBRICATION SYSTEM 6-3

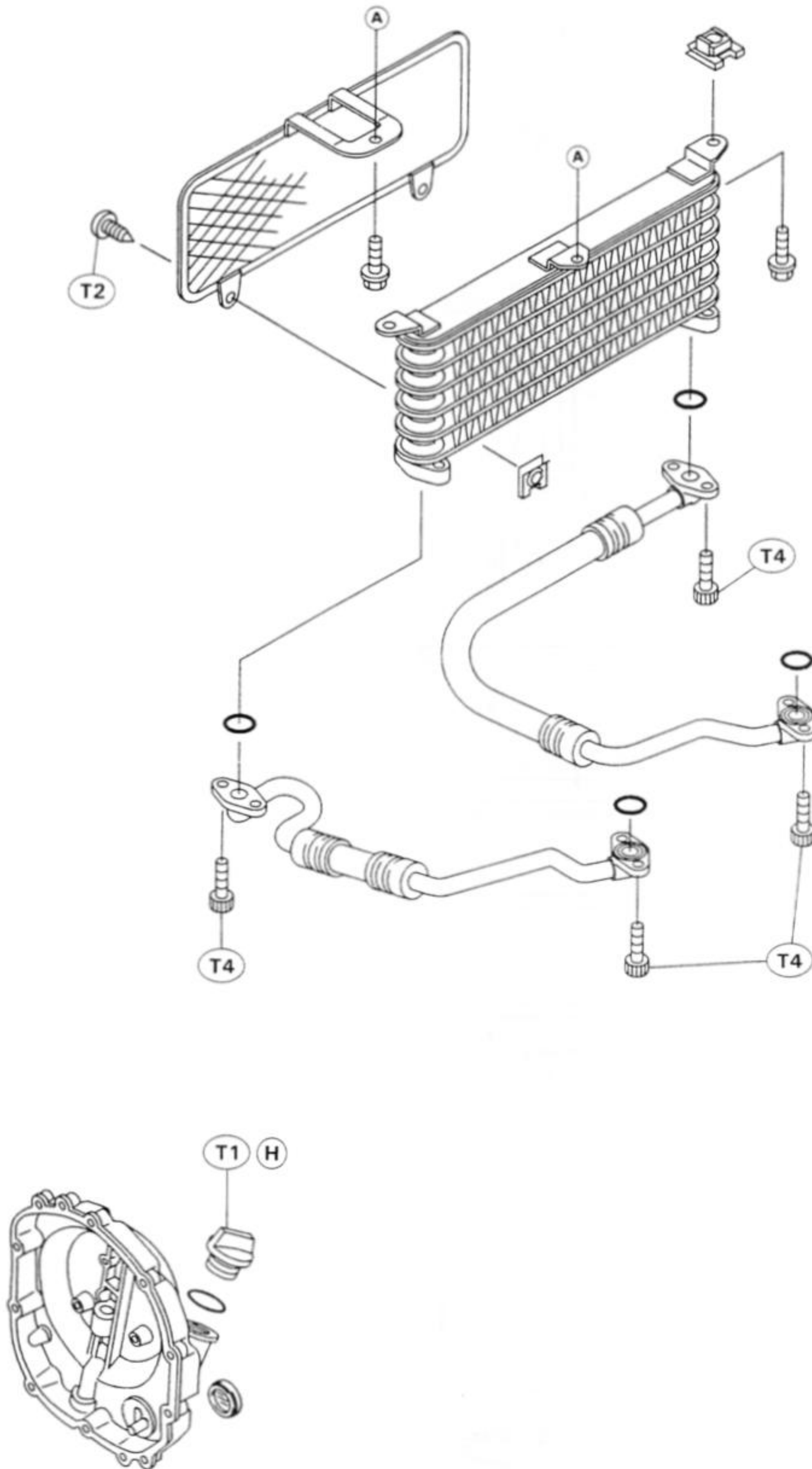

6-4 ENGINE LUBRICATION SYSTEM

Engine Oil Flow Chart

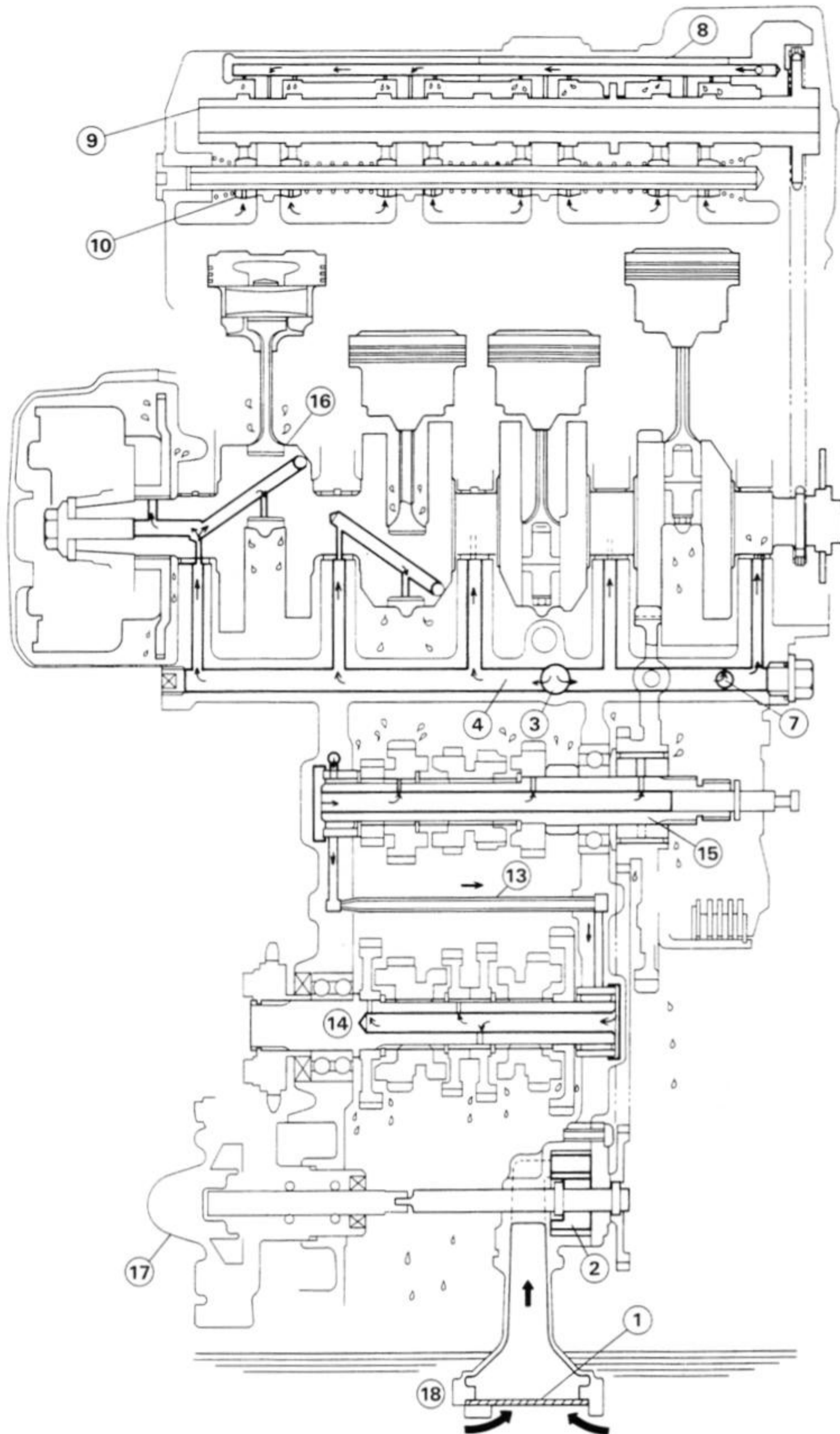

ENGINE LUBRICATION SYSTEM 6-5

1. Oil Pump Filter
2. Oil Pump
3. Oil Filter
4. Oil Passage
5. Oil Pressure Switch
6. Relief Valve
7. Oil Hose
8. Camshaft Bracket
9. Camshaft
10. Rocker Arm
11. Oil Return Passage
12. Oil Pipe (to Mission)
13. Oil Pipe (to Output Shaft)
14. Output Shaft
15. Drive Shaft
16. Crankshaft
17. Water Pump
18. Oil Pan
19. Oil Drain Plug
20. Oil Return Hose
21. Breather Plate
22. Breather Hose
23. Oil Cooler
24. Oil Cooler Hose
25. Bypass Hole

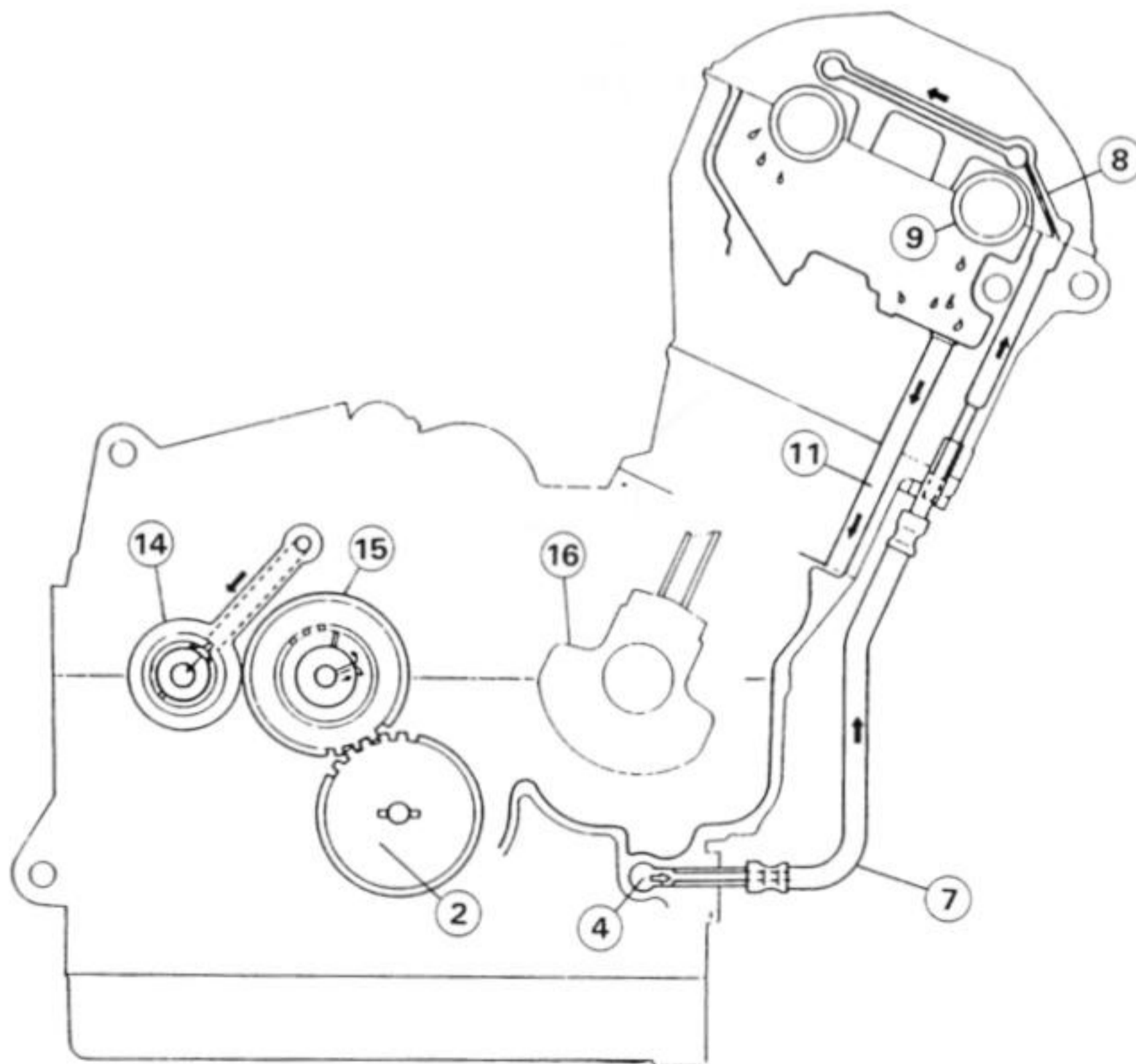
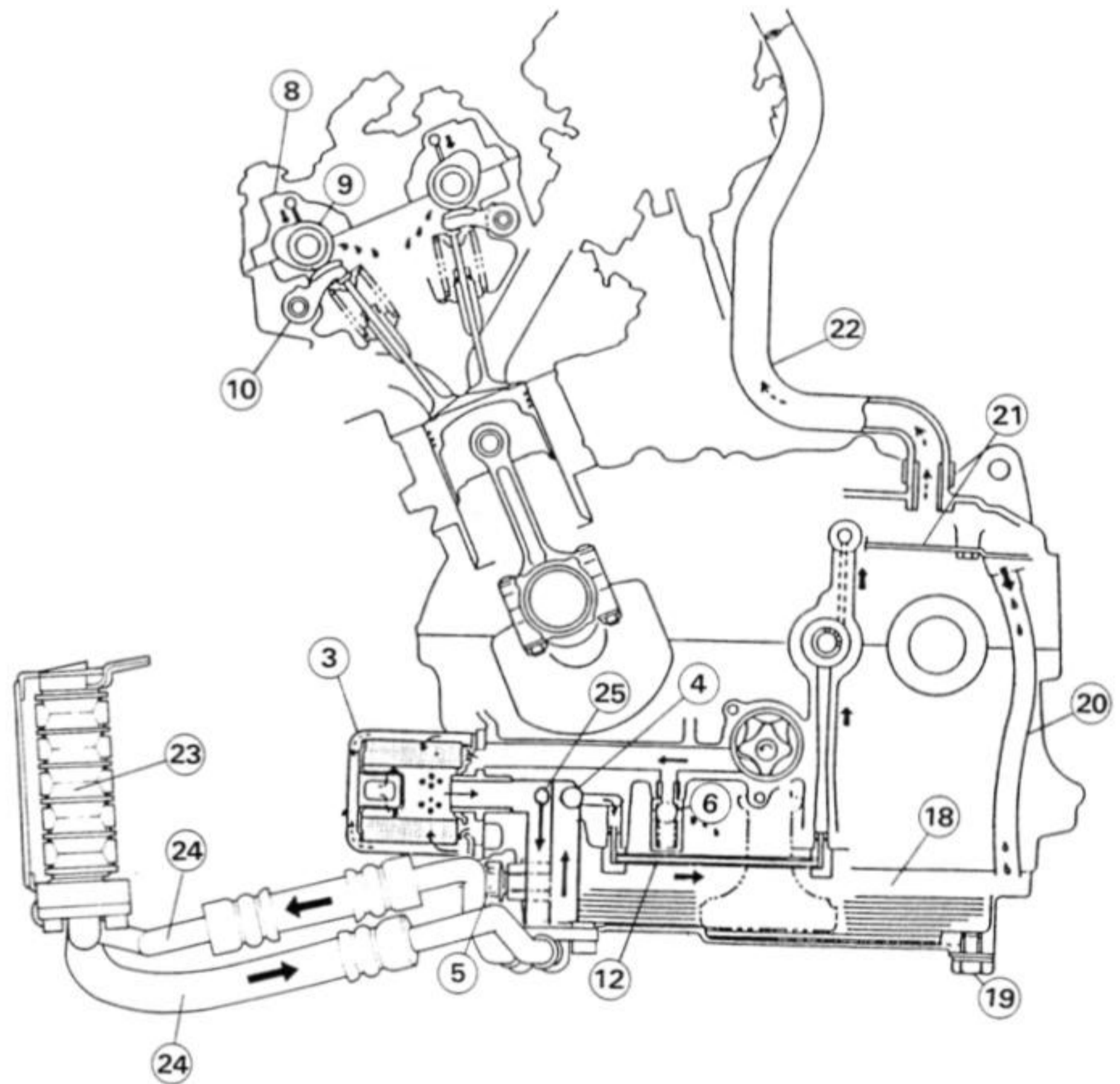

6-6 ENGINE LUBRICATION SYSTEM

Specifications

Item	Standard
Engine Oil: Grade Viscosity Capacity	SE or SF class SAE 10W-40 2.8 L (when filter is not removed) 3.0 L (when filter is removed)
Oil Pressure Measurement: Oil pressure @4 000 r/min (rpm), oil temp. 90°C (194°F)	216 ~ 275 kPa (2.2 ~ 2.8 kg/cm ² , 31 ~ 40 psi)

Special Tools

Oil Pressure Gauge, 10 kg/cm²: 57001-164

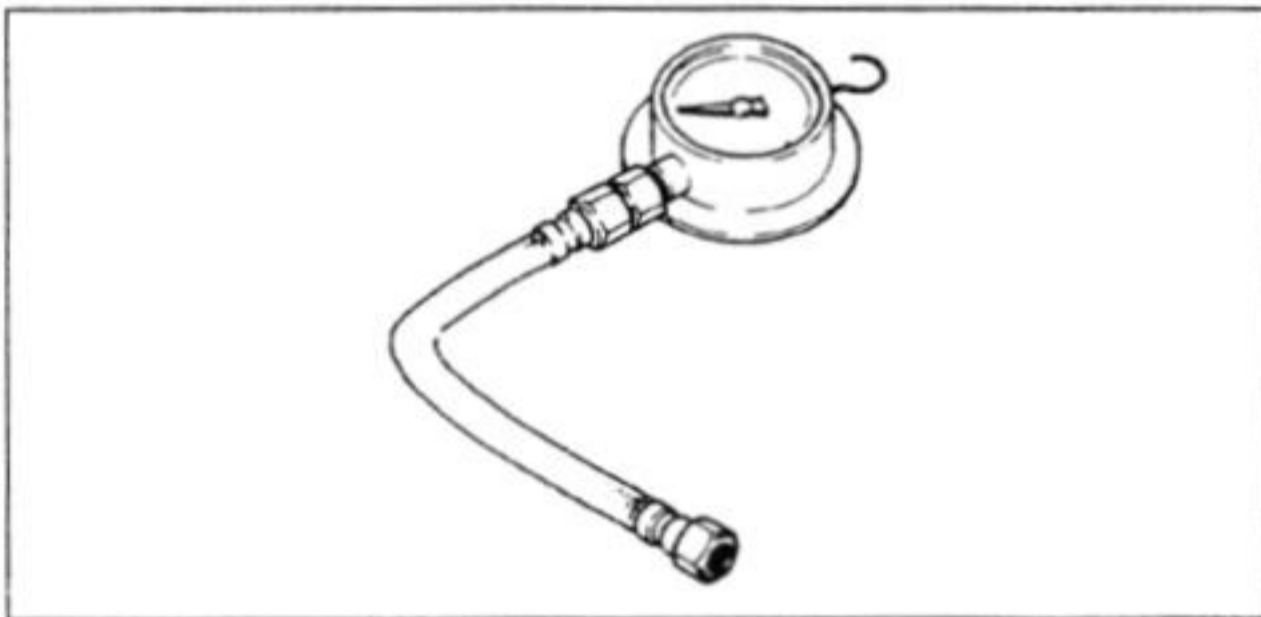

Oil Pressure Gauge Adapter, M18 x 1.5: 57001-1278

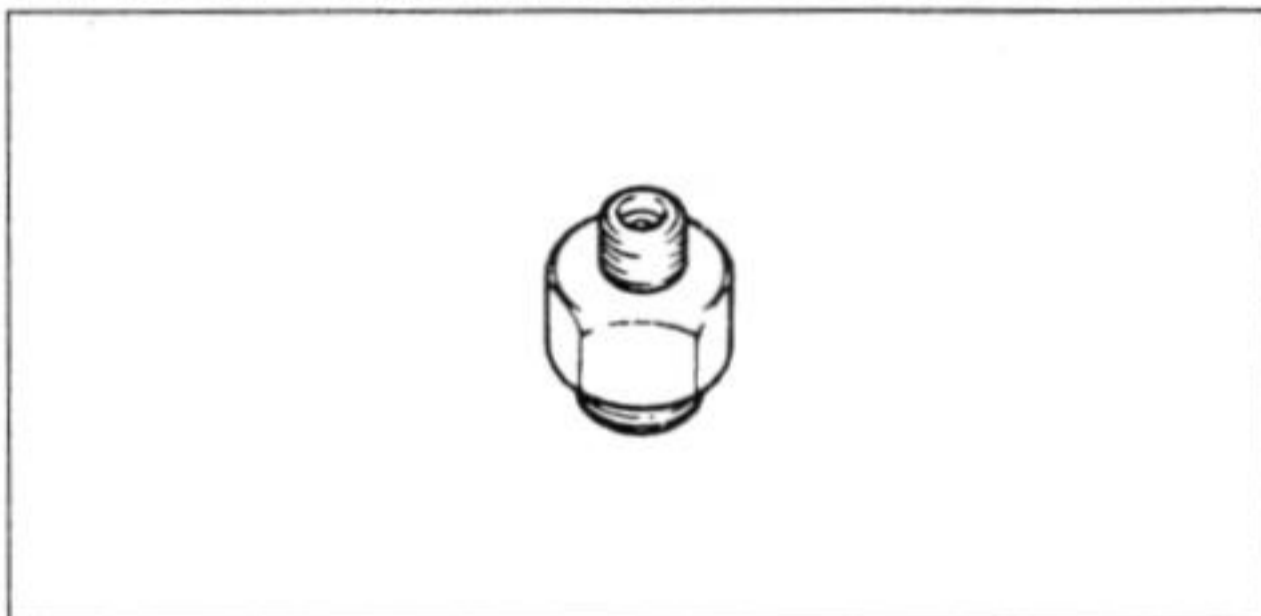

Sealant

Kawasaki Bond (Silicone Sealant): 56019-120

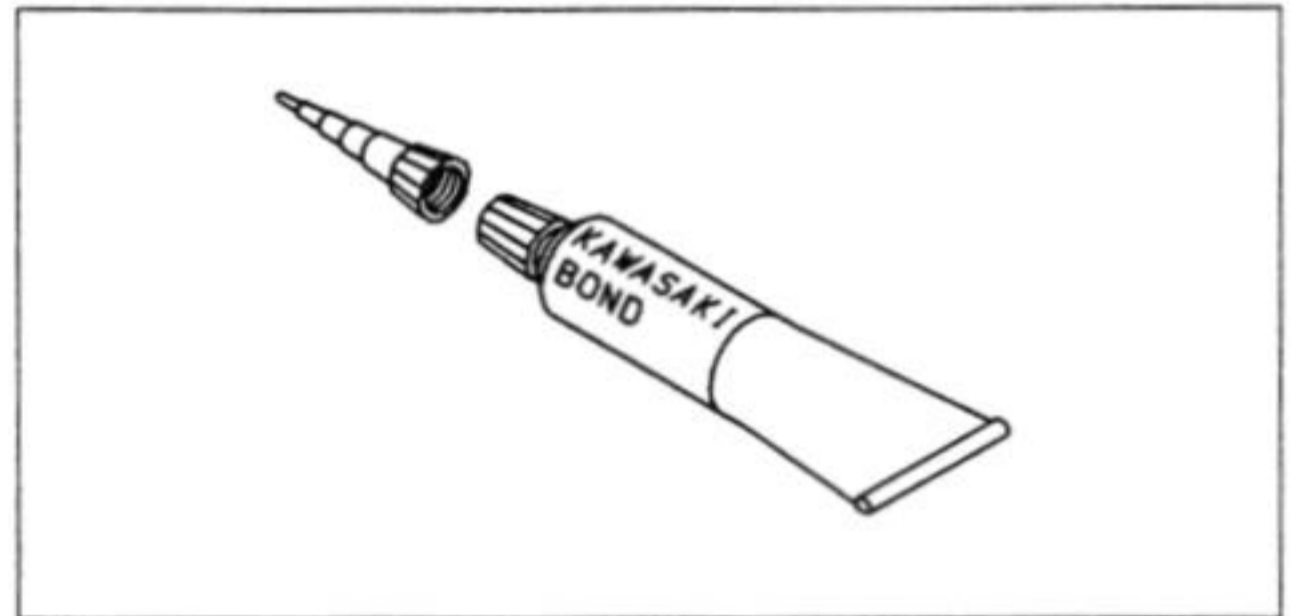

Engine Removal / Installation

Table of Contents

Exploded View	7-2
Special Tool.....	7-3

7-2 ENGINE REMOVAL / INSTALLATION

Exploded View

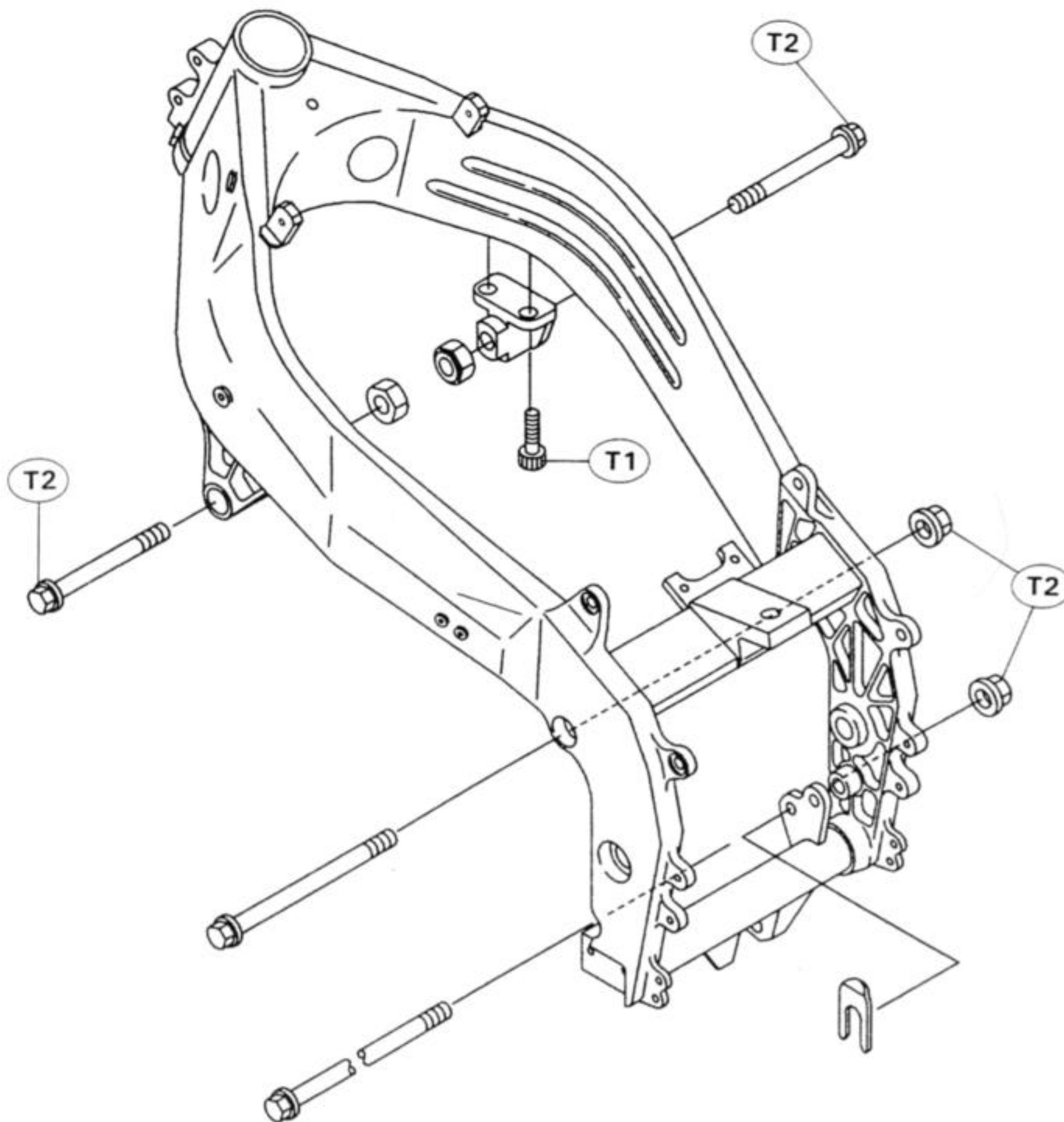

T1 : 25 N-m (2.5 kg-m, 18 ft-lb)
T2 : 44 N-m (4.5 kg-m, 33 ft-lb)

Special Tool

Jack: 57001-1238

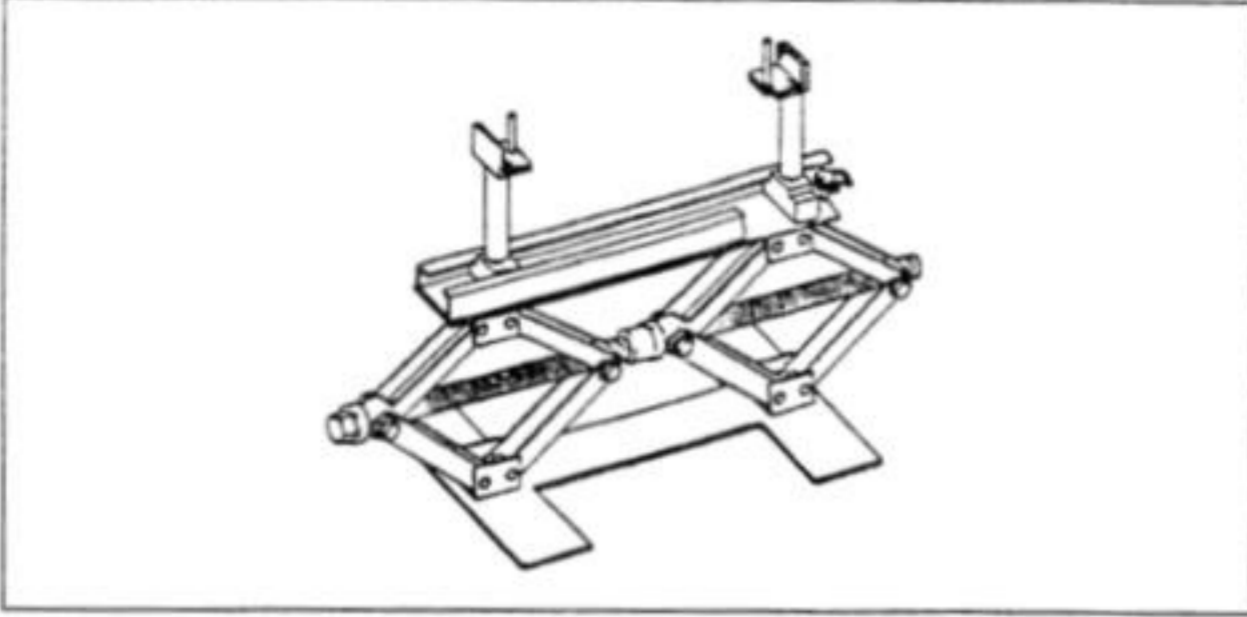

Crankshaft / Transmission

Table of Contents

Exploded View	8-2
Specifications	8-4
Special Tools	8-6
Sealant	8-6
Crankcase	8-7
Crankcase Assembly Note	8-7

8-2 CRANKSHAFT / TRANSMISSION

Exploded View

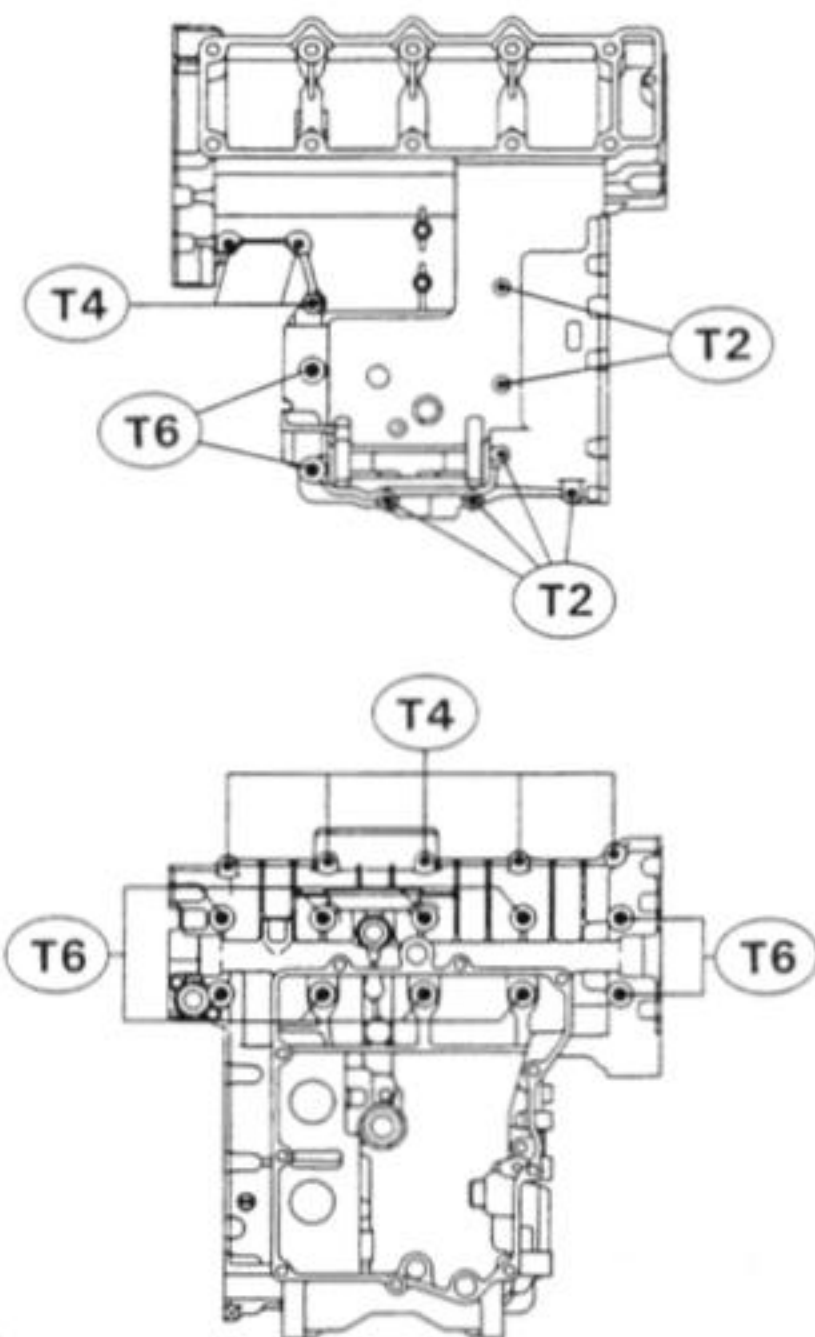
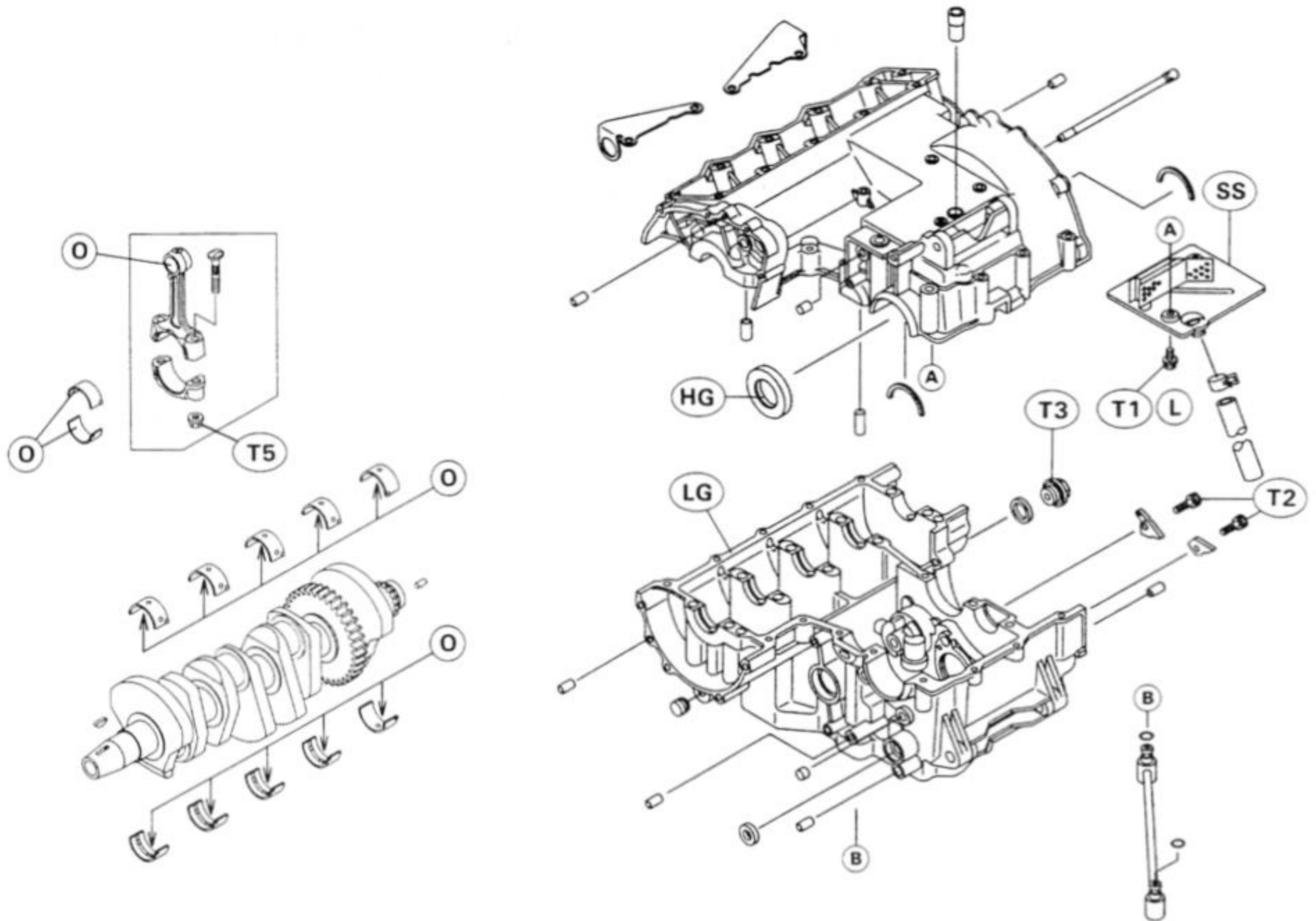

T1 : 9.8 N-m (1.0 kg-m, 7.0 ft-lb)

T2 : 12 N-m (1.2 kg-m, 8.5 ft-lb)

T3 : 15 N-m (1.5 kg-m, 11.0 ft-lb)

T4 : 20 N-m (2.0 kg-m, 14.5 ft-lb)

T5 : 25 N-m (2.6 kg-m, 19 ft-lb)

T6 : 27 N-m (2.8 kg-m, 20 ft-lb)

G : Apply grease.

HG : Apply high temperature grease.

LG : Apply liquid gasket – black (Kawasaki Bond: 92104-1003) to the mating surface of the right and left crankcase halves.

L : Apply a non-permanent locking agent to the threads.

SS : Apply silicone sealant (Kawasaki Bond: 56019-120) to the gaskets and the threads.

O : Apply oil.

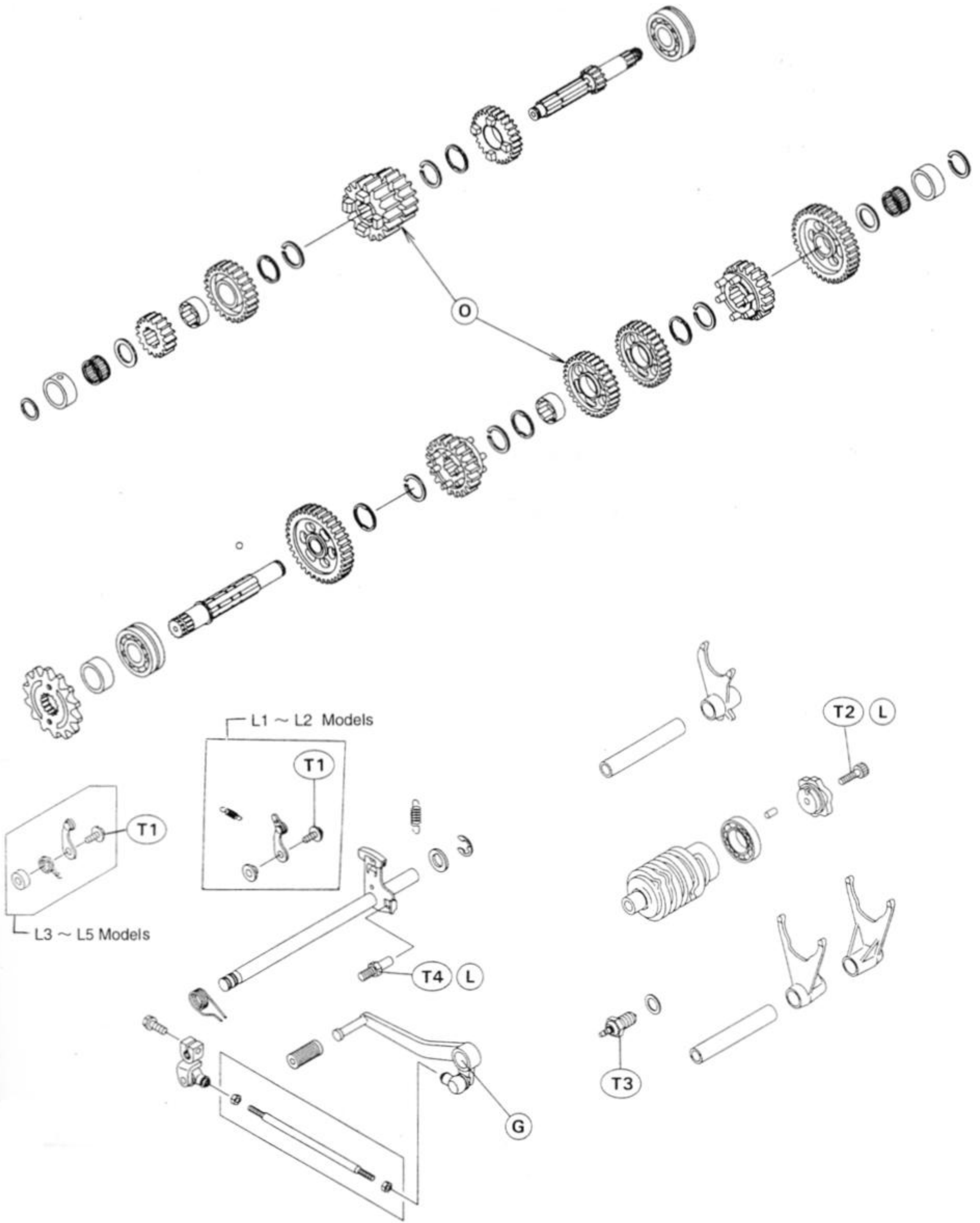

8-4 CRANKSHAFT / TRANSMISSION

Specifications

Item	Standard	Service Limit																					
Crankshaft, Connecting Rods:																							
Connecting rod big end side clearance	0.13 ~ 0.38 mm	0.60 mm																					
Connecting rod big end bearing insert/crankpin clearance	0.031 ~ 0.059 mm	0.10mm																					
Crankpin diameter:	29.984 ~ 30.000 mm	29.97 mm																					
Marking	None	- - -																					
	○	- - -																					
Connecting rod big end bore diameter:	33.000 ~ 33.016 mm	- - -																					
Marking	None	- - -																					
	○	- - -																					
Connecting rod big end bearing insert thickness:																							
	Brown	- - -																					
	Black	- - -																					
	Blue	- - -																					
Connecting rod big end bearing insert selection:																							
<table border="1"> <thead> <tr> <th rowspan="2">Con-Rod Big End Bore Diameter Marking</th> <th rowspan="2">Crankpin Diameter Marking</th> <th colspan="2">Bearing Insert</th> </tr> <tr> <th>Size Color</th> <th>Part Number</th> </tr> </thead> <tbody> <tr> <td>○</td> <td>None</td> <td>Blue</td> <td>92028-1492</td> </tr> <tr> <td>None</td> <td>None</td> <td rowspan="2">Black</td> <td rowspan="2">92028-1493</td> </tr> <tr> <td>○</td> <td>○</td> </tr> <tr> <td>None</td> <td>○</td> <td>Brown</td> <td>92028-1494</td> </tr> </tbody> </table>				Con-Rod Big End Bore Diameter Marking	Crankpin Diameter Marking	Bearing Insert		Size Color	Part Number	○	None	Blue	92028-1492	None	None	Black	92028-1493	○	○	None	○	Brown	92028-1494
Con-Rod Big End Bore Diameter Marking	Crankpin Diameter Marking	Bearing Insert																					
		Size Color	Part Number																				
○	None	Blue	92028-1492																				
None	None	Black	92028-1493																				
○	○																						
None	○	Brown	92028-1494																				
Crankshaft side clearance	0.05 ~ 0.20 mm	0.40 mm																					
Crankshaft runout	0.02 mm or less	0.05 mm TIR																					
Crankshaft main bearing insert, journal clearance	0.014 ~ 0.038 mm	0.08 mm																					
Crankshaft main journal diameter:	29.984 ~ 30.000 mm	29.96 mm																					
Marking	None	- - -																					
	1	- - -																					
Crankcase main bearing bore diameter:	33.000 ~ 33.016 mm	- - -																					
Marking	○	- - -																					
	None	- - -																					
Crankshaft main bearing insert thickness:																							
	Brown	- - -																					
	Black	- - -																					
	Blue	- - -																					
	1.491 ~ 1.495 mm	- - -																					
	1.495 ~ 1.499 mm	- - -																					
	1.499 ~ 1.503 mm	- - -																					

CRANKSHAFT / TRANSMISSION 8-5

Item	Standard	Service Limit
Crankshaft main bearing insert selection:		
Crankcase Main Bearing Bore Diameter Mark	Crankshaft Main Journal Diameter Mark	Bearing Insert*
		Size Color Part Number Journal Nos.
○	1	Brown
		92028-1418 5
		92028-1421 1, 2, 3, 4
○	None	Black
		92028-1417 5
None	1	92028-1420 1, 2, 3, 4
None	None	Blue
		92028-1416 5
		92028-1419 1, 2, 3, 4
*The bearing inserts for No. 5 has no oil groove.		
Transmission: Shift fork ear thickness Gear shift fork groove width Shift fork guide pin diameter Shift drum groove width	4.9 ~ 5.0 mm 5.05 ~ 5.15 mm 5.9 ~ 6.0 mm 6.05 ~ 6.20 mm	4.8 mm 5.3 mm 5.8 mm 6.3 mm

8-6 CRANKSHAFT / TRANSMISSION

Special Tools

Socket Wrench, Hex 8: 57001-1268

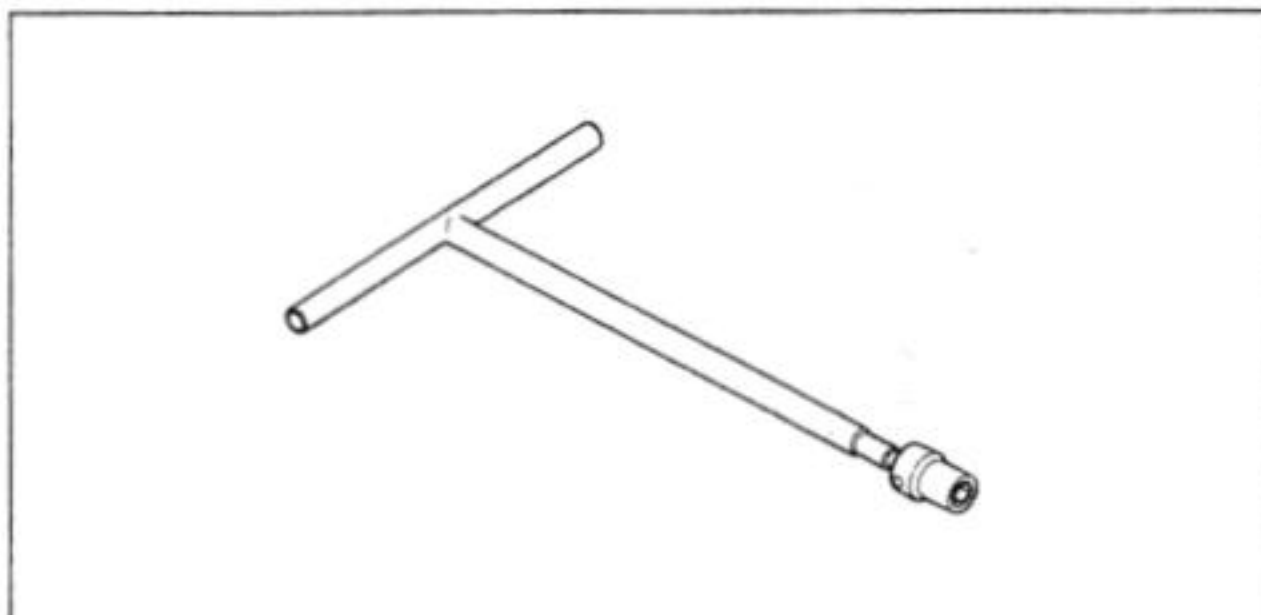

Outside Circlip Pliers: 57001-144

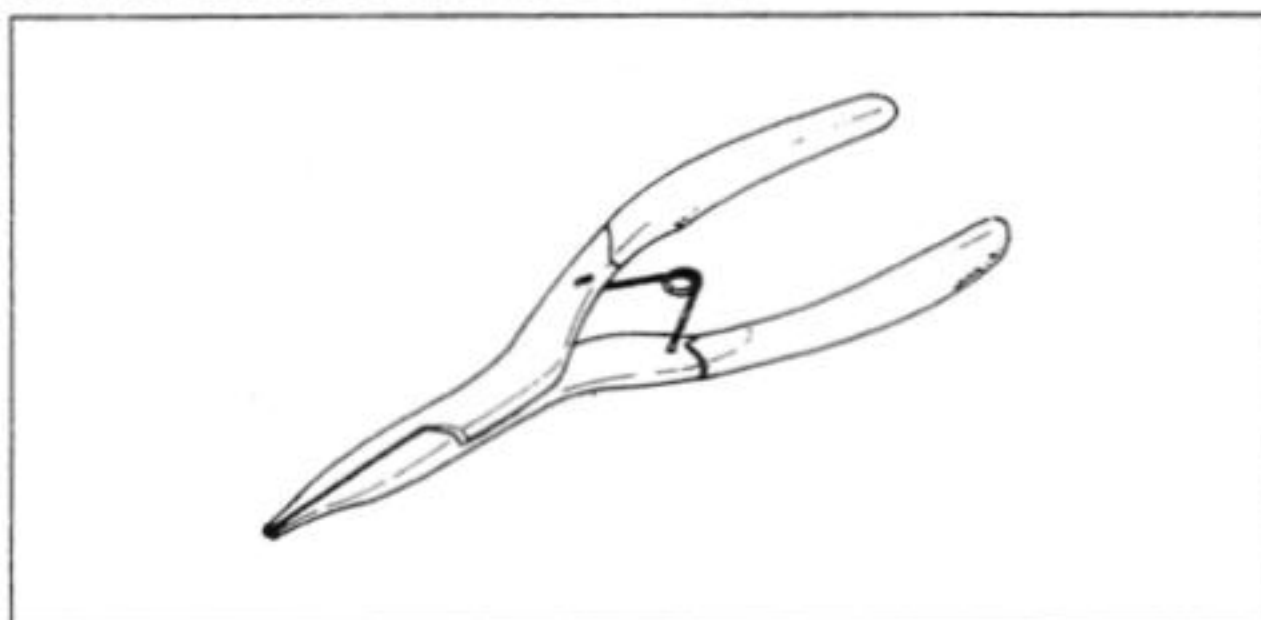

Bearing Driver Set: 57001-1129



Sealant

Kawasaki Bond (Silicone Sealant): 56019-120

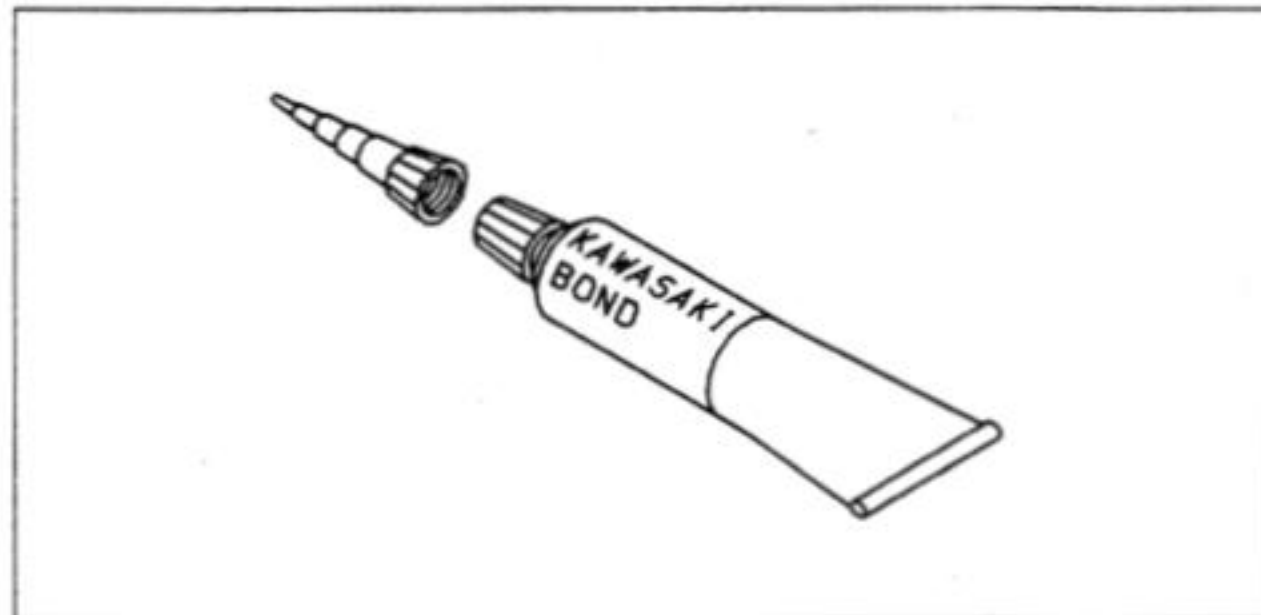

Kawasaki Bond (Liquid Gasket - Silver): 92104-002

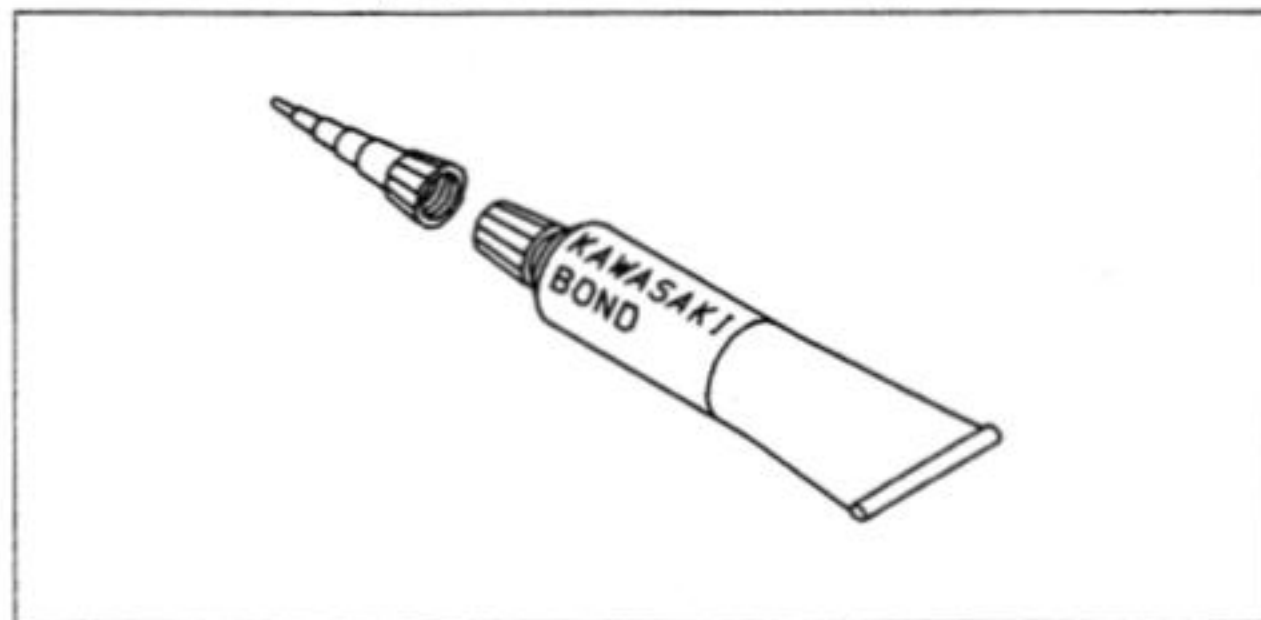

Crankcase

Crankcase Assembly Note

Refer to the base manual, noting the following.

The crankcase bolt seating surfaces on the radiator brackets should be cleaned with a high flash-point solvent before bolt tightening.

This prevent the bolt from getting over tightening on the plate.

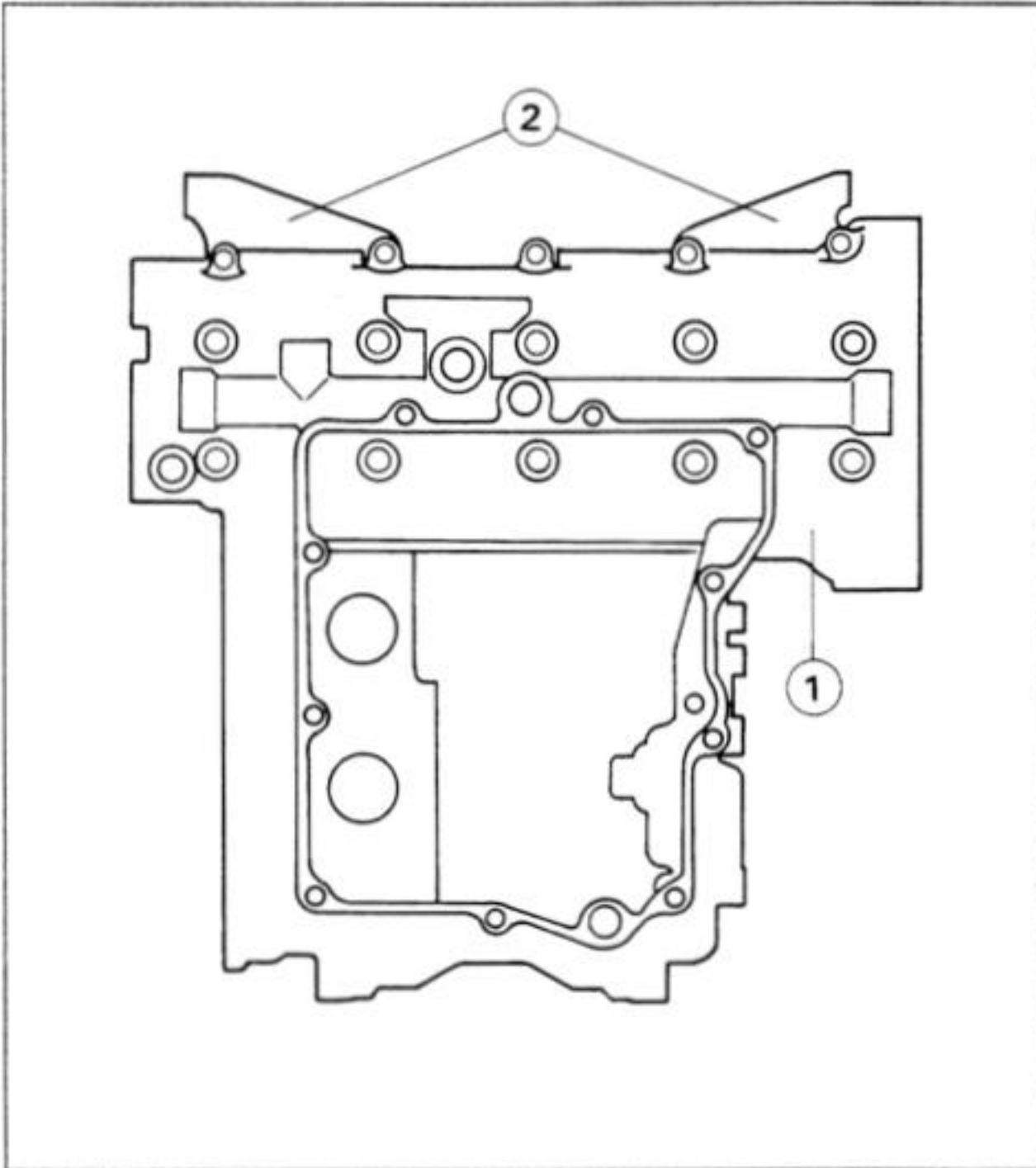

1. Lower Crankcase

2. Radiator Bracket

Wheels / Tires

Table of Contents

Exploded View9-2
Specifications9-3
Special Tools9-4

9-2 WHEELS / TIRES

Exploded View

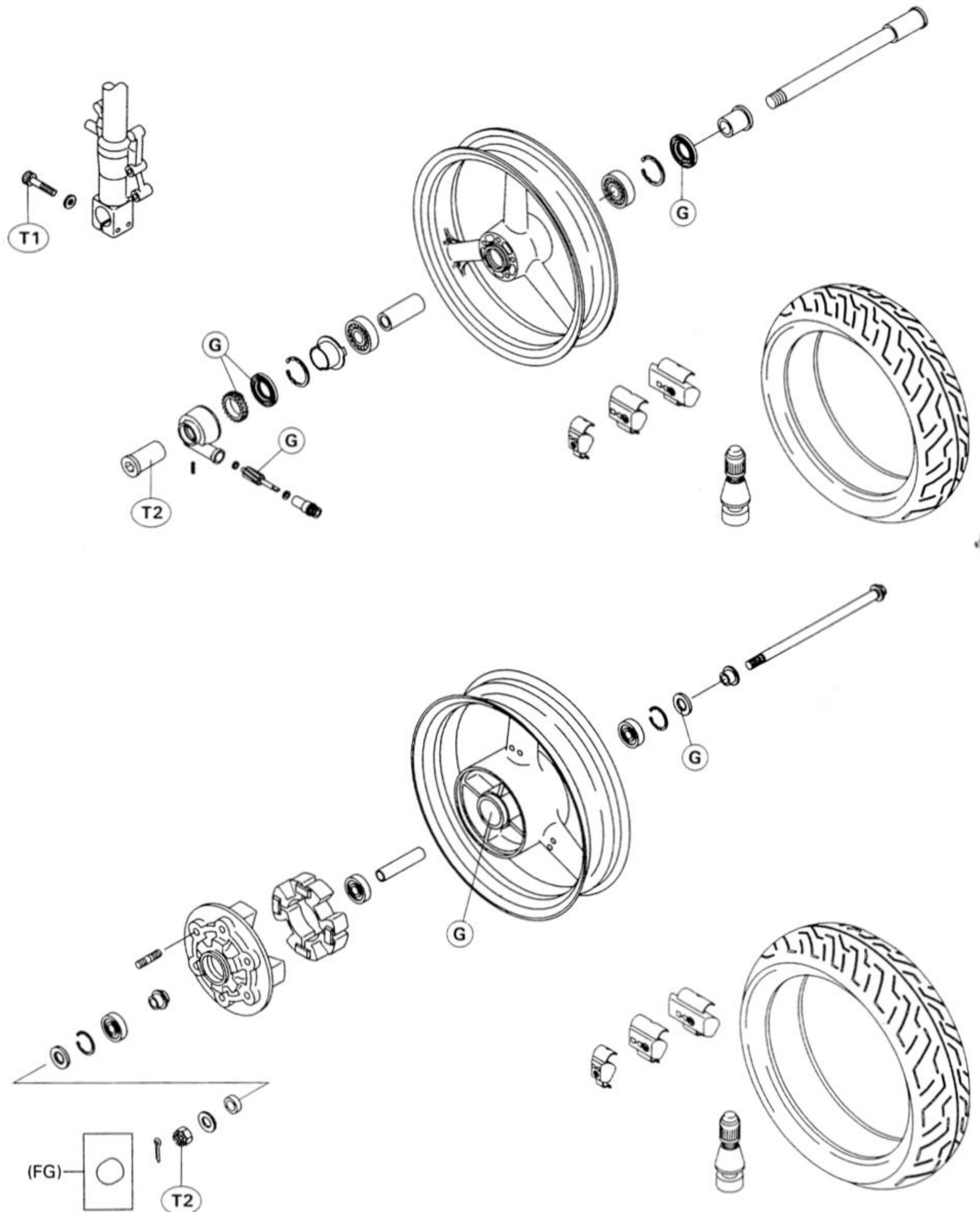

T1 : 20 N-m (2.0 kg-m, 14.5 ft-lb)
T2 : 110 N-m (11 kg-m, 80 ft-lb)

G : Apply grease.
FG : German Model

Specifications

Item	Standard	Service Limit
Wheels: Rim runout: Axial Radial Axle runout/100 mm	--- --- TIR 0.05 mm or less	TIR 0.5 mm TIR 0.8 mm TIR 0.2 mm
Tires: Air pressure (when cold): Front:  Rear:	Up to 185 kg (408 lb) load: 225 kPa (2.25 kg/cm ² , 32 psi): BRIDGESTONE (CYROX-17) BRIDGESTONE (BT50F)(BT57F) METZELER PIRELLI 250 kPa (2.50 kg/cm ² , 36 psi): DUNLOP (D204 F) CONTINENTAL MICHELIN Up to 185 kg (408 lb) load: 250 kPa (2.50 kg/cm ² , 36 psi): BRIDGESTONE (CYROX-20) BRIDGESTONE (BT50R)(BT57R) METZELER PIRELLI 290 kPa (2.90 kg/cm ² , 41 psi): DUNLOP (D204) CONTINENTAL MICHELIN	. --- --- --- ---
Tread depth: Front Rear	3.4 mm 5.8 mm	1 mm 2 mm
Standard tire: Front: Rear:	Make, Type BRIDGESTONE, CYROX-17, Tubeless (FG) BRIDGESTONE, BT50F RADIAL G, Tubeless (FG) BRIDGESTONE, BT57F, Tubeless (FG) METZELER, MEZ1 Front, Tubeless (FG) PIRELLI, MTR01, Tubeless (FG) DUNLOP, D204F, Tubeless (FG) CONTINENTAL, Conti-Radial 2000F, Tubeless (FG) MICHELIN, TX15, Tubeless BRIDGESTONE, CYROX-20, Tubeless (FG) BRIDGESTONE, BT50R RADIAL G, Tubeless (FG) BRIDGESTONE, BT57R, Tubeless (FG) METZELER, MEZ1, Tubeless (FG) PIRELLI, MTR02, Tubeless (FG) DUNLOP, D204, Tubeless (FG) CONTINENTAL, Conti-Radial 2000, Tubeless (FG) MICHELIN, TX25, Tubeless	Size 120/60 VR 17 120/60 ZR17 160/60 VR 17 160/60 ZR17

(FG): German Model

9-4 WHEELS / TIRES

Special Tools

Bearing Driver Set: 57001-1129



Bearing Remover Head, $\phi 15 \times \phi 17$: 57001-1267

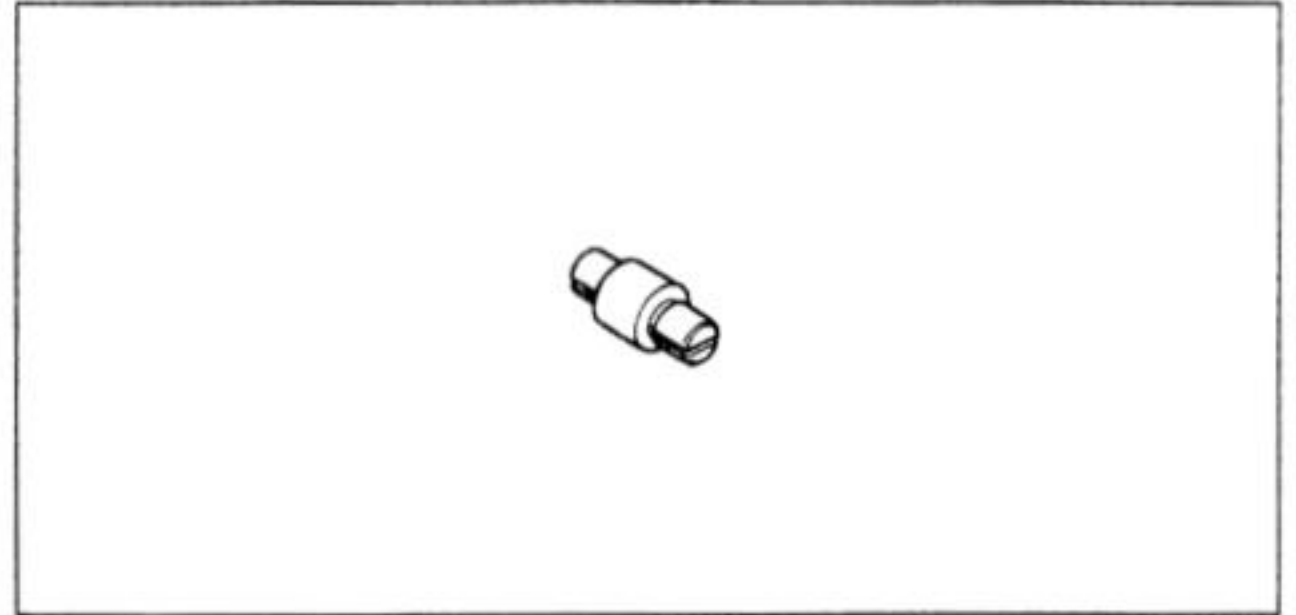

Jack: 57001-1238

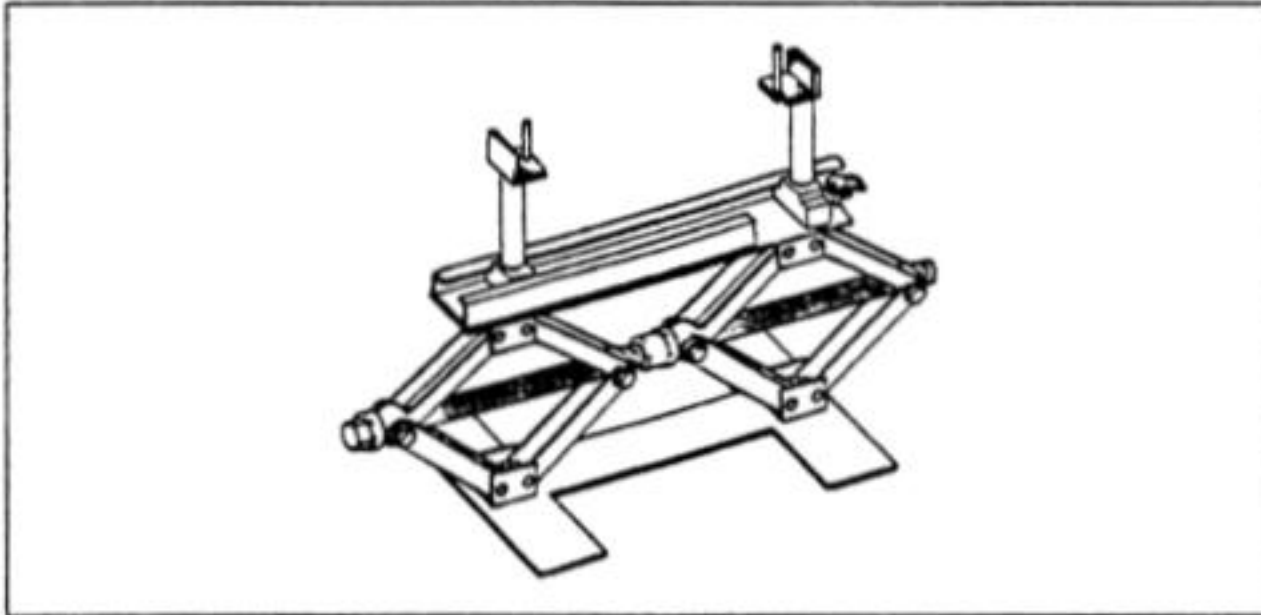

Bearing Remover Head, $\phi 20 \times \phi 22$: 57001-1293

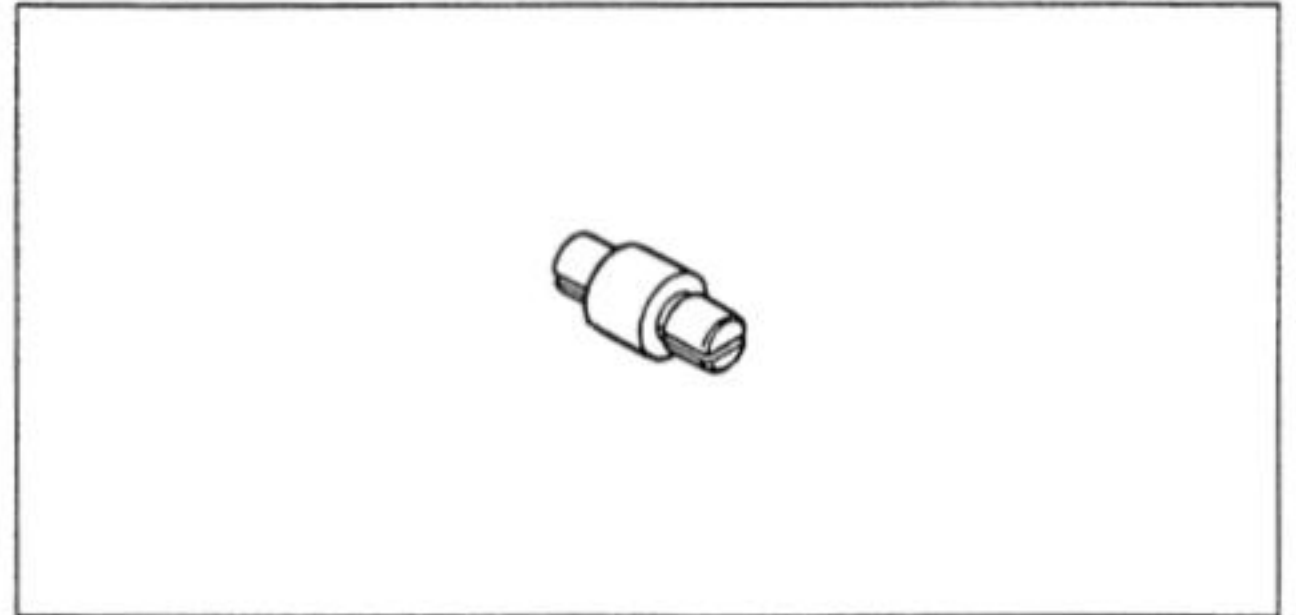

Bead Breaker Assembly: 57001-1072

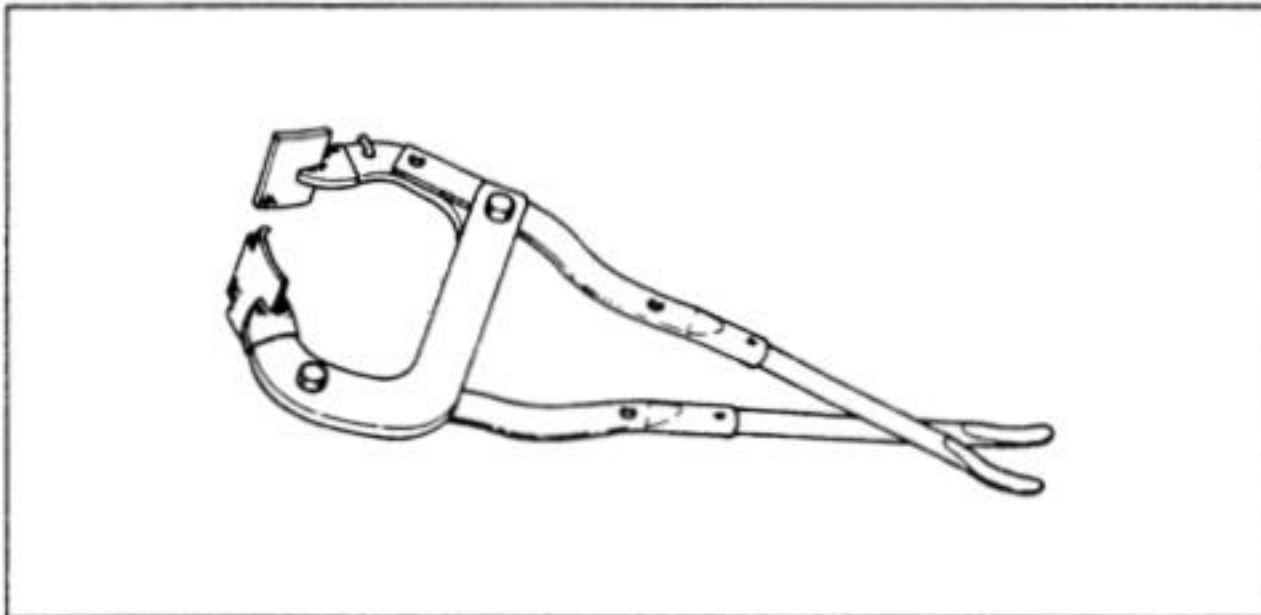

Inside Circlip Pliers: 57001-143

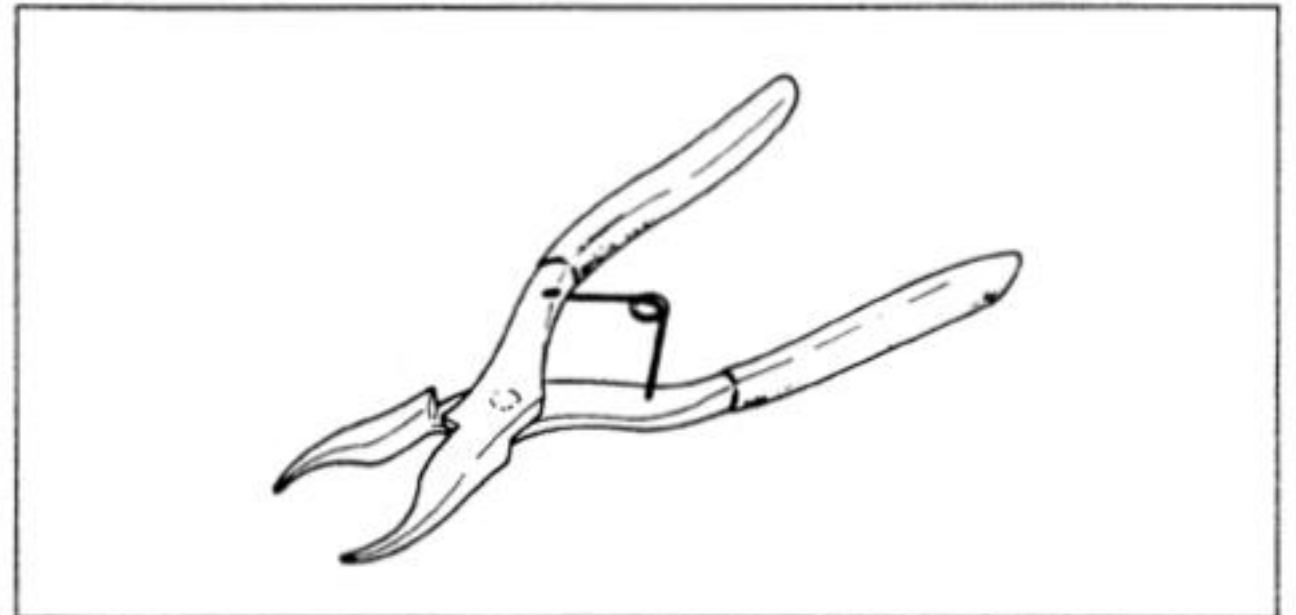

Rim Protector: 57001-1063

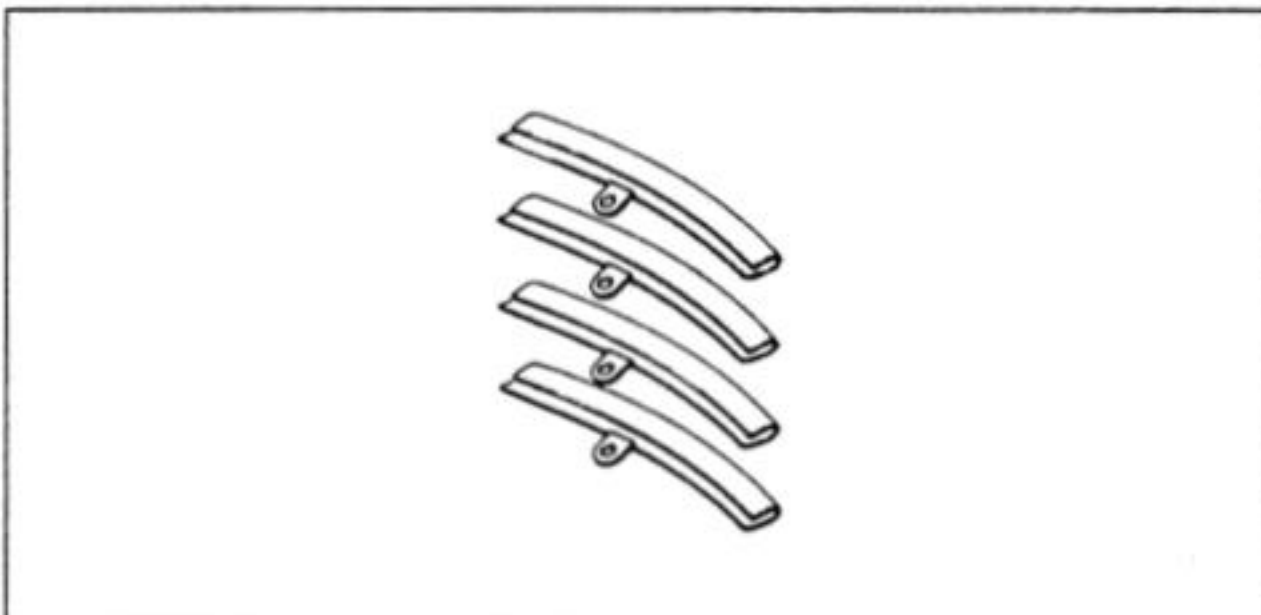

Bearing Remover Shaft: 57001-1265

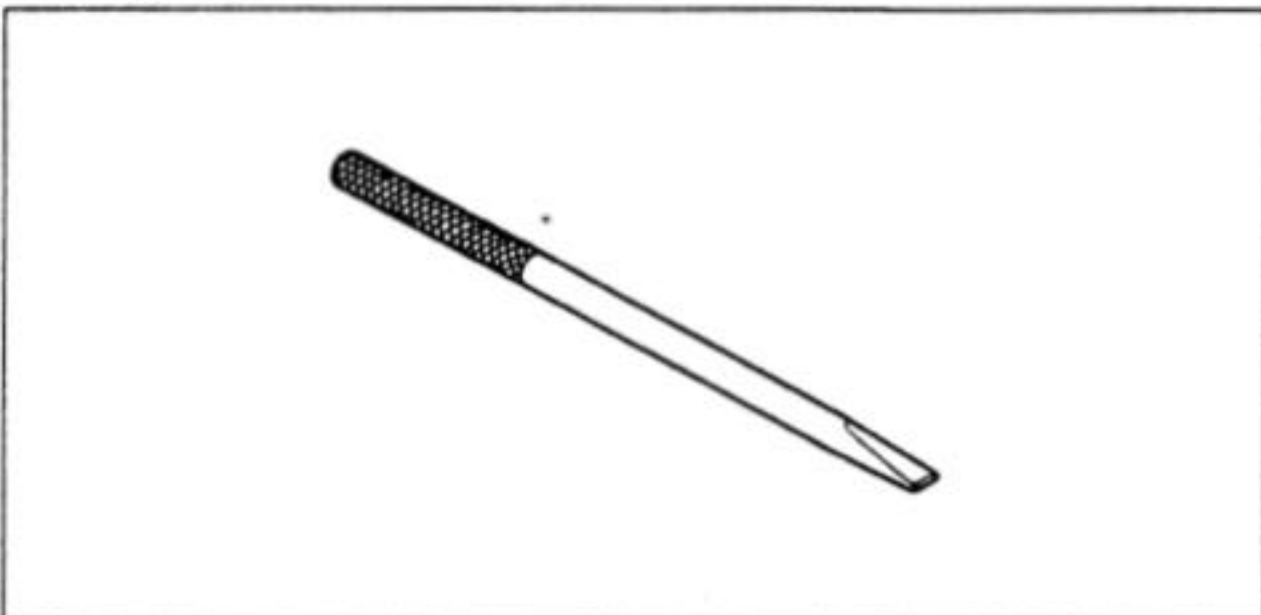

Final Drive

Table of Contents

Exploded View	10-2
Specifications	10-3
Special Tools	10-3
Drive Chain.....	10-4
Slack Adjustment.....	10-4
Wheel Alignment Adjustment	10-5
Wear Inspection	10-5
Lubrication	10-5

10-2 FINAL DRIVE

Exploded View

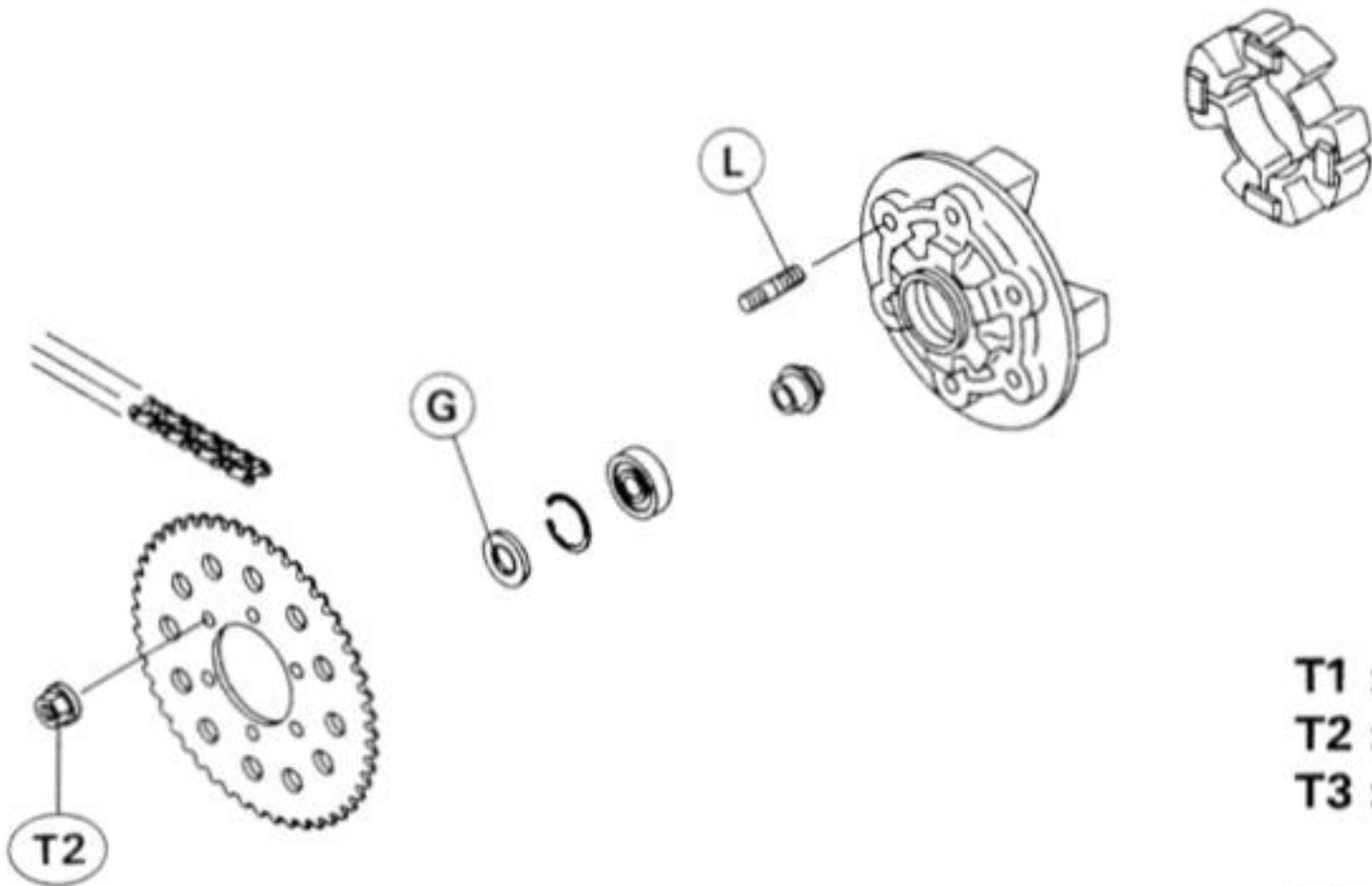
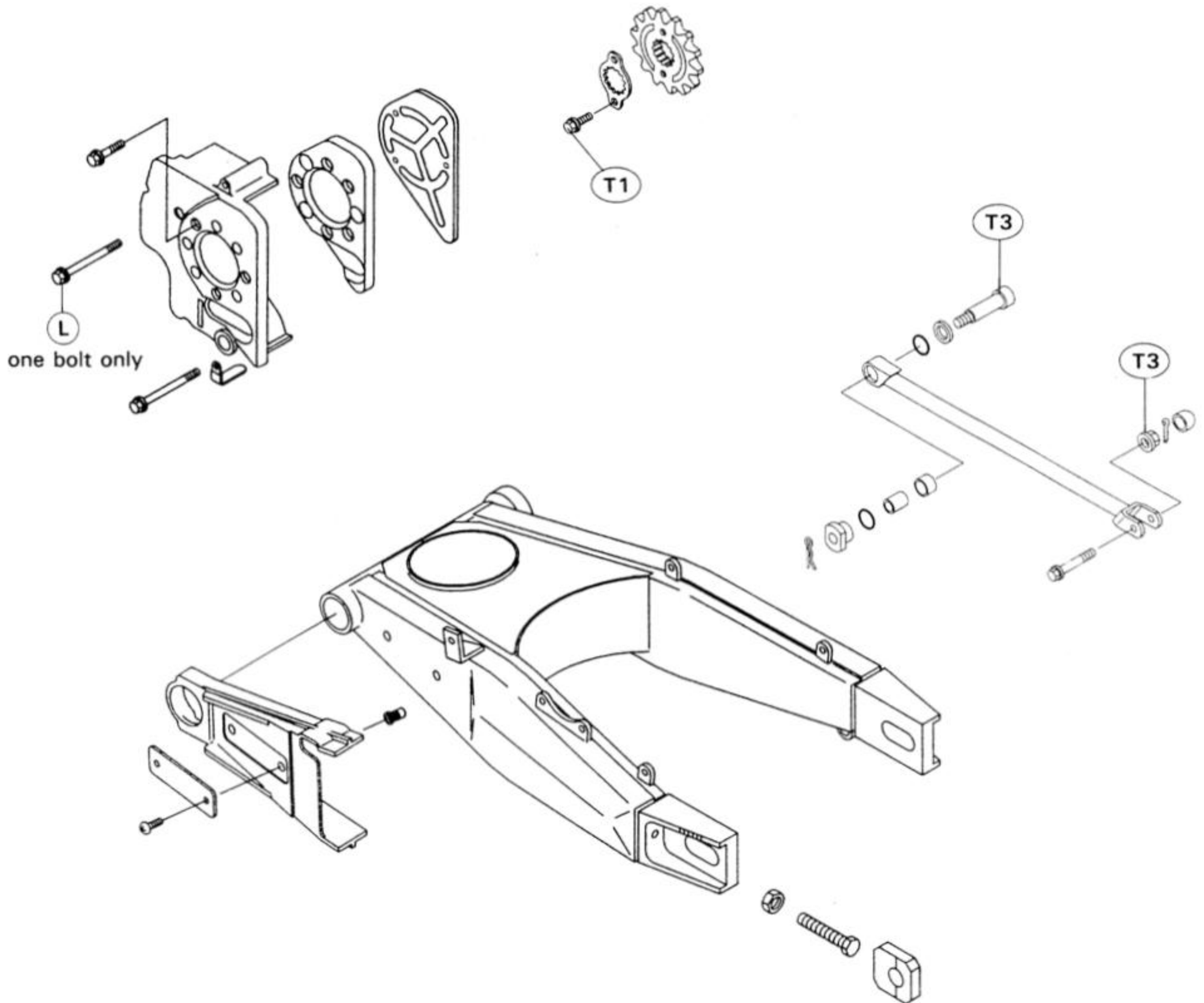

- T1 : 8.8 N-m (0.9 kg-m, 78 in-lb)
- T2 : 74 N-m (7.5 kg-m, 54 ft-lb)
- T3 : 25 N-m (2.5 kg-m, 18 ft-lb)

G : Apply grease.
L : Apply a non-permanent locking agent to the threads.

Specifications

Item	Standard	Service Limit
Drive Chain: Make and type Chain slack Chain 20-link length	ENUMA EK520-MV-02 Endless 110 links 5 ~ 10 mm 317.5 ~ 318.2 mm	- - - Less than 5 mm, or more than 15 mm 323 mm

Special Tools

Jack: 57001-1238

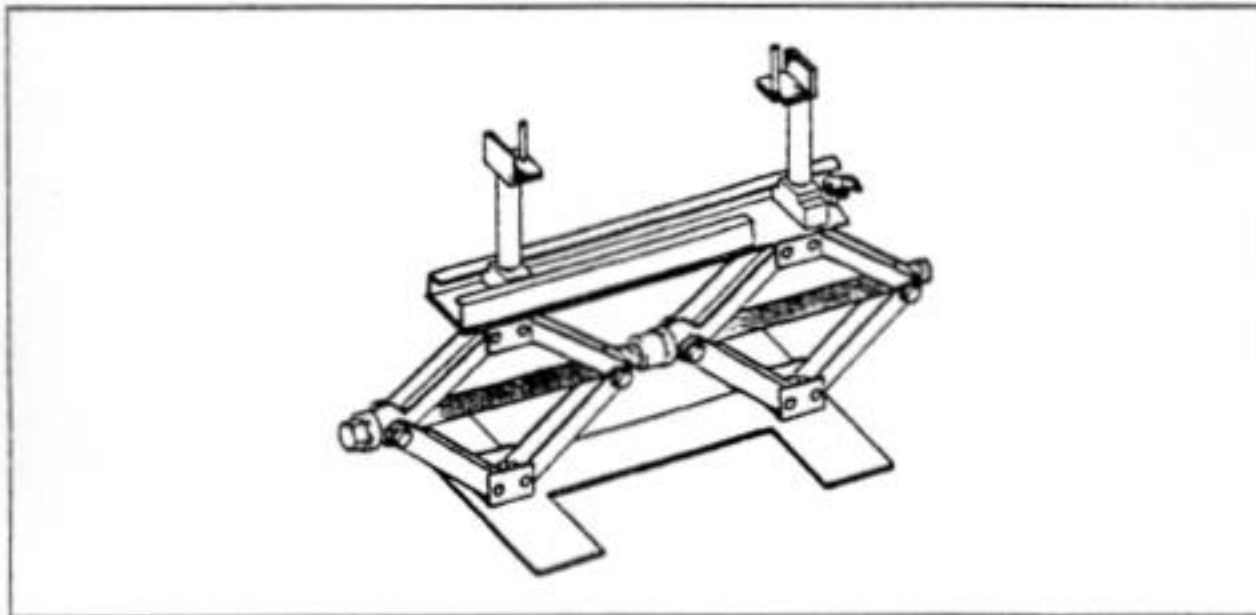

Inside Circlip Pliers: 57001-143

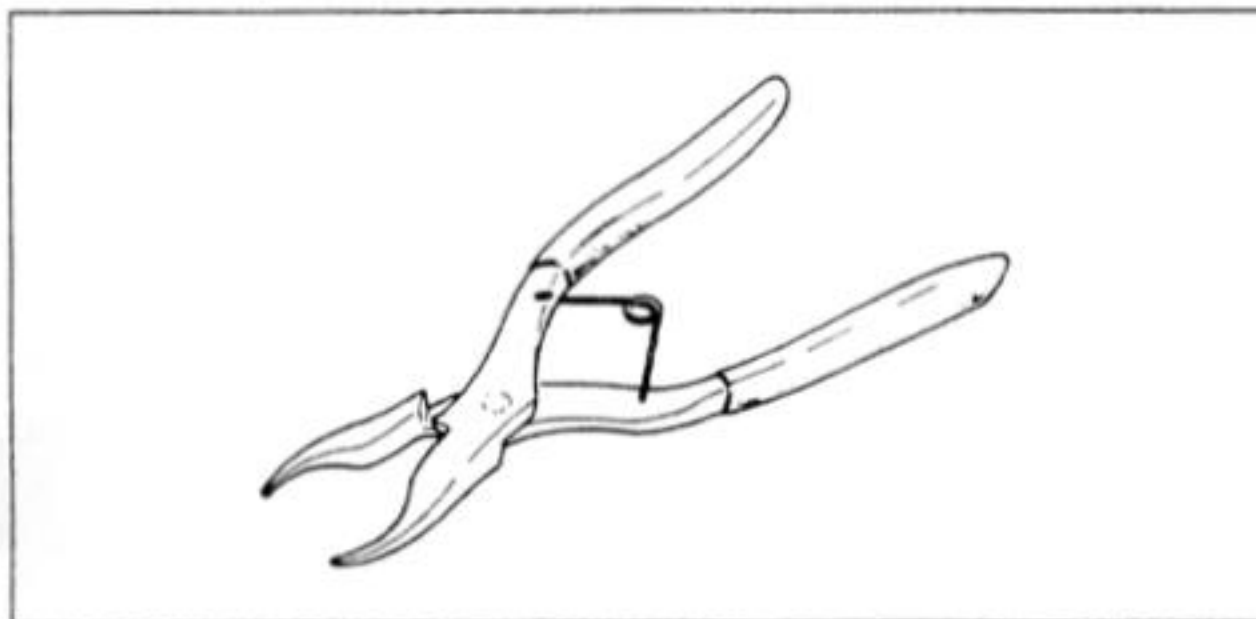

Bearing Driver Set: 57001-1129



10-4 FINAL DRIVE

Drive Chain

Slack Adjustment

- Set the motorcycle up on its side stand.
- Check to see that the notches on the alignment indicators on both sides are in the same relative position.
- ★ If they are not, adjust the chain slack and align them.

⚠ WARNING

Misalignment of the wheel will result in abnormal wear and may result in an unsafe riding condition.

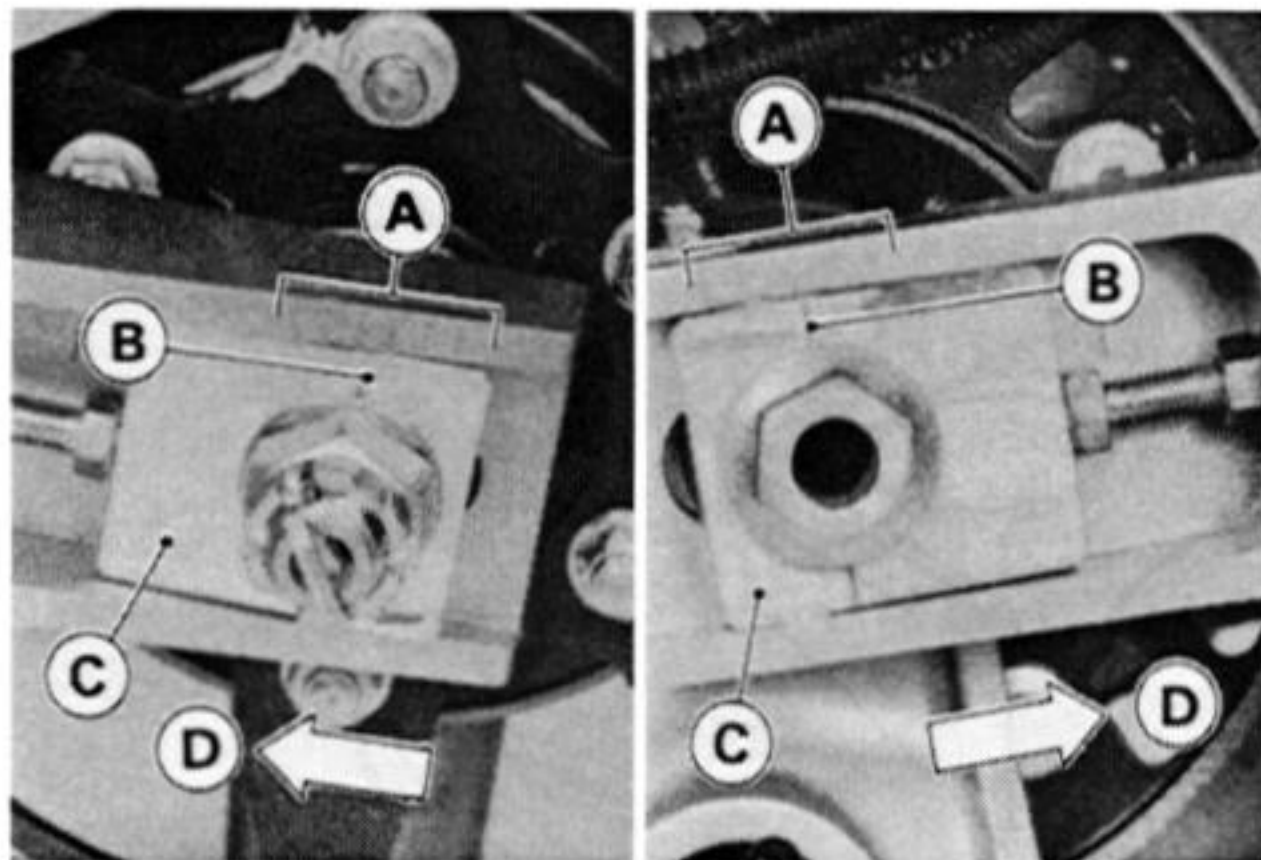

A. Swing Arm Marks
B. Notch
C. Alignment Indicator
D. Front

NOTE

○ Clean the chain if it is dirty, and lubricate it if it appears dry.

- Check the chain slack.
- Turn the rear wheel to find the position where the chain is tightest.
- Push up the chain at the rear end of the lower chain guard, and measure the distance from the chain upper end to the swing arm.

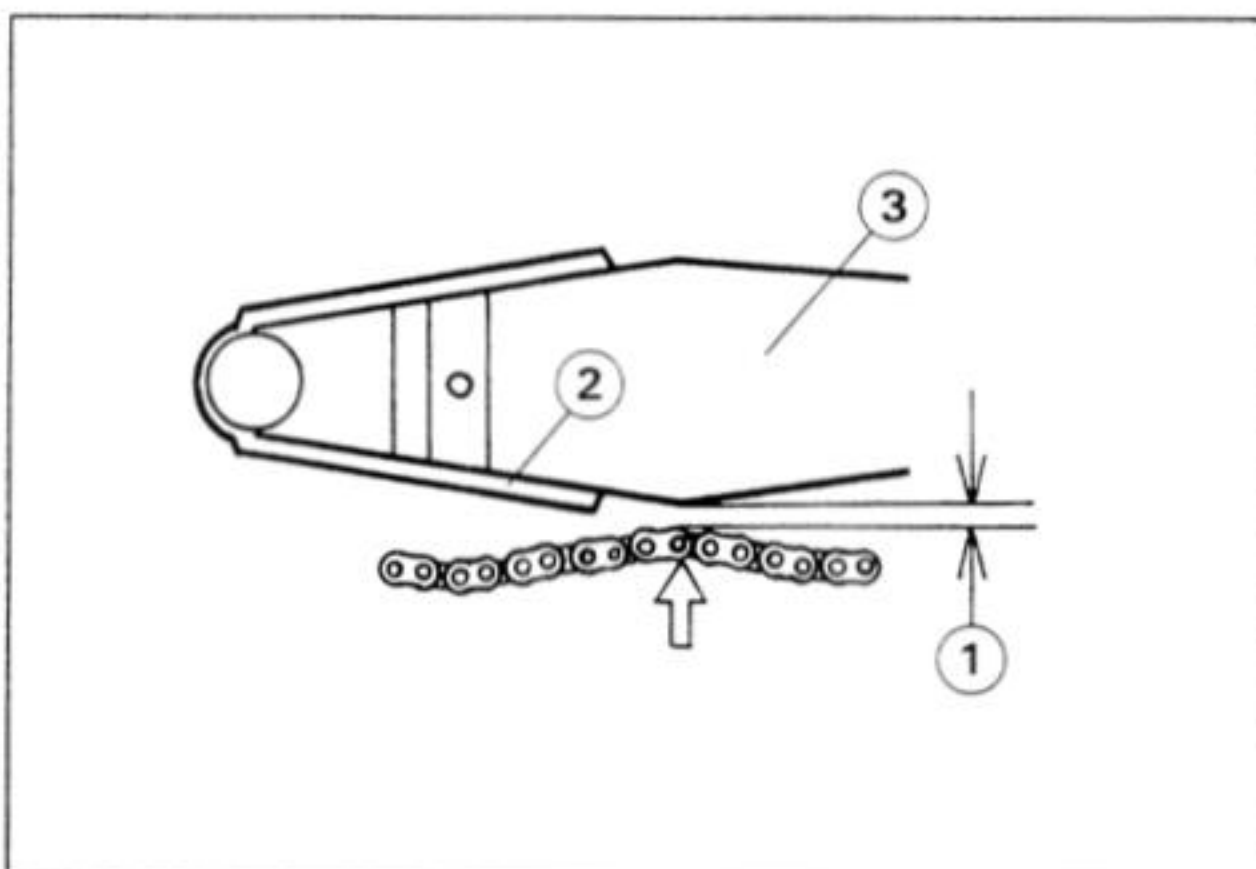

1. Chain Slack
2. Chain Guard
3. Swing Arm

Chain Slack

Standard:	5 ~ 10 mm
Too Tight:	Less than 5 mm
Too Loose:	More than 15 mm

★ If the chain slack exceeds the standard, adjust it as follows.

- Loosen the following nuts.
 - Both Chain Adjuster Locknuts
 - Axle Nut

NOTE

○ Do not loosen the torque link nut.

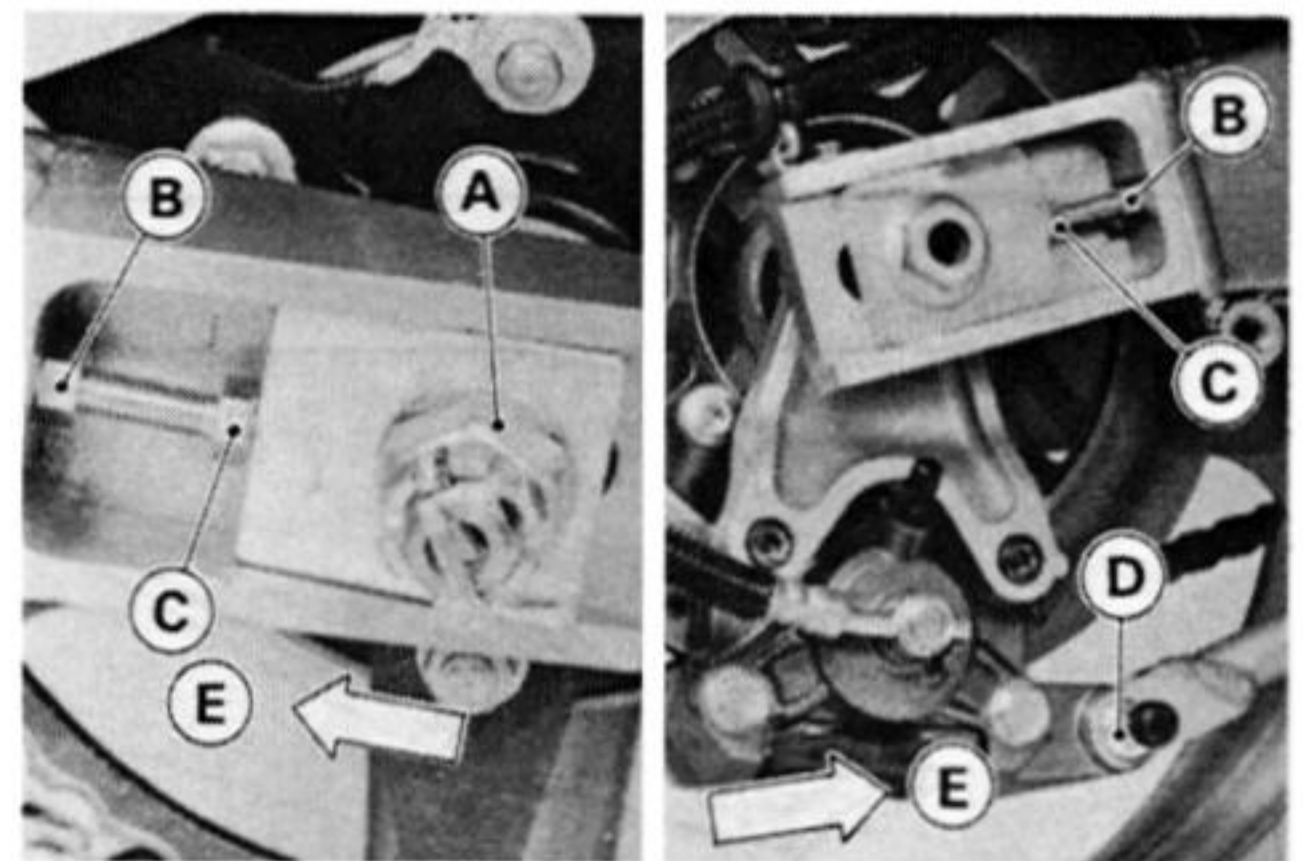

A. Axle Nut
B. Locknuts
C. Adjusters
D. Torque Link Nut
E. Front

★ If the chain is too loose, turn out the left and right chain adjusters evenly.

★ If the chain is too tight, turn in the left and right chain adjusters evenly, and kick the wheel forward.

- Turn both chain adjusters evenly until the drive chain has the correct amount of slack. To keep the chain and wheel properly aligned, the notch on the left wheel alignment indicator should align with the same swing arm mark that the right indicator notch aligns with.

⚠ WARNING

Misalignment of the wheel will result in abnormal wear and may result in an unsafe riding condition.

- Tighten both chain adjuster locknuts securely.
- Tighten the axle nut to the specified torque (see Exploded View).

⚠ WARNING

If the axle nut is not securely tightened, an unsafe riding condition may result.

- Turn the wheel, measure the chain slack again at the tightest position, and readjust if necessary.
- Insert a new cotter pin and spread its ends.
- Check the rear brake effectiveness.

⚠ WARNING

Do not attempt to drive the motorcycle until a full brake pedal is obtained by pumping the brake pedal until the pads are against the disc. The brakes will not function on the first application of the pedal if this is not done.

Wheel Alignment Adjustment

- Check that the notch on the left alignment indicator aligns with the same swing arm mark that the right alignment indicator notch aligns with.
- ★ If they are not, adjust the chain slack and align the wheel alignment (see Drive Chain Slack Adjustment).

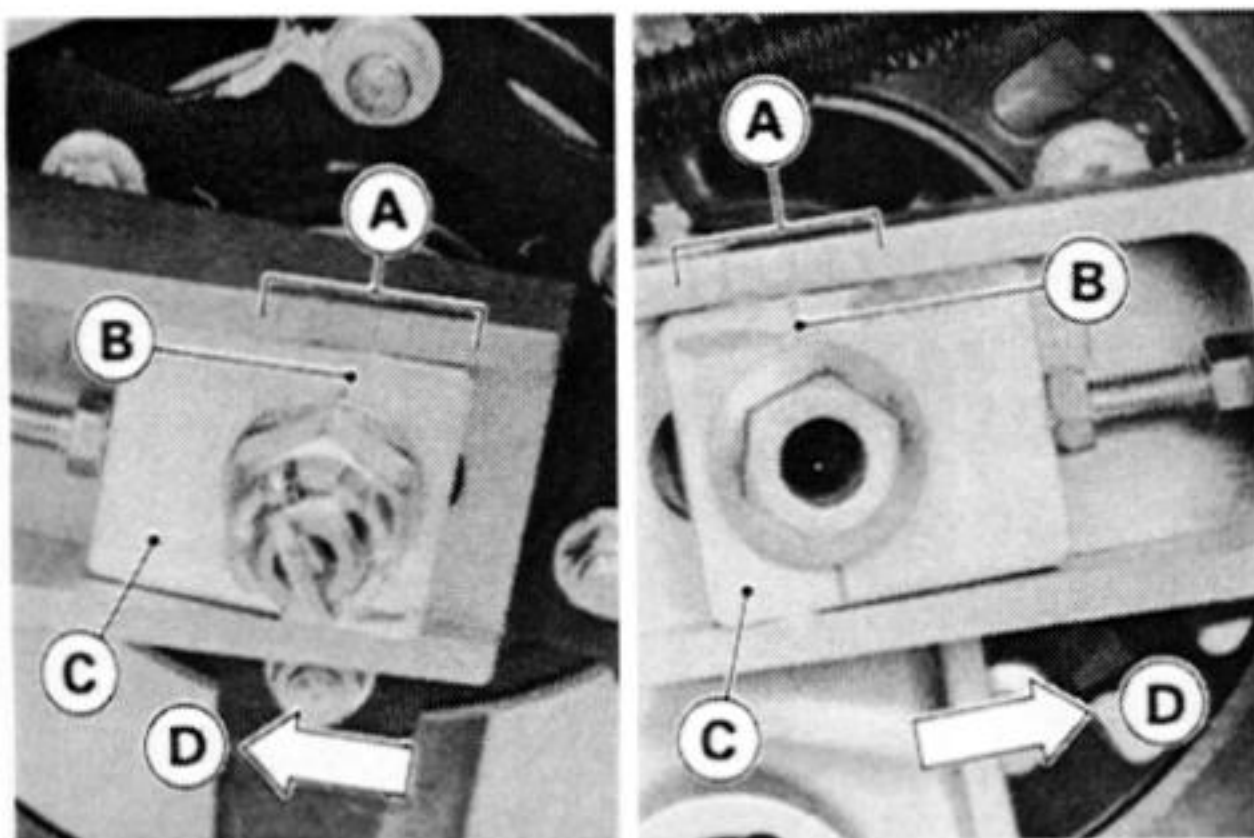

A. Marks
B. Notch
C. Alignment Indicator
D. Front

NOTE

○ Wheel alignment can be also be checked using the straightedge or string method.

⚠ WARNING

Misalignment of the wheel will result in abnormal wear, and may result in an unsafe riding condition.

Wear Inspection

- Rotate the rear wheel to inspect the drive chain for damaged rollers, and loose pins and links.
- ★ If there is any irregularity, replace the drive chain.
- ★ Lubricate the drive chain if it appears dry (see this chapter).
- Stretch the chain taut hanging a 98 N (10 kg, 20 lb) weight on the chain.
- Measure the length of 20 links on the straight part of the chain from pin center of the 1st pin to pin center of the 21st pin. Since the chain may wear unevenly, take measurement at several places.

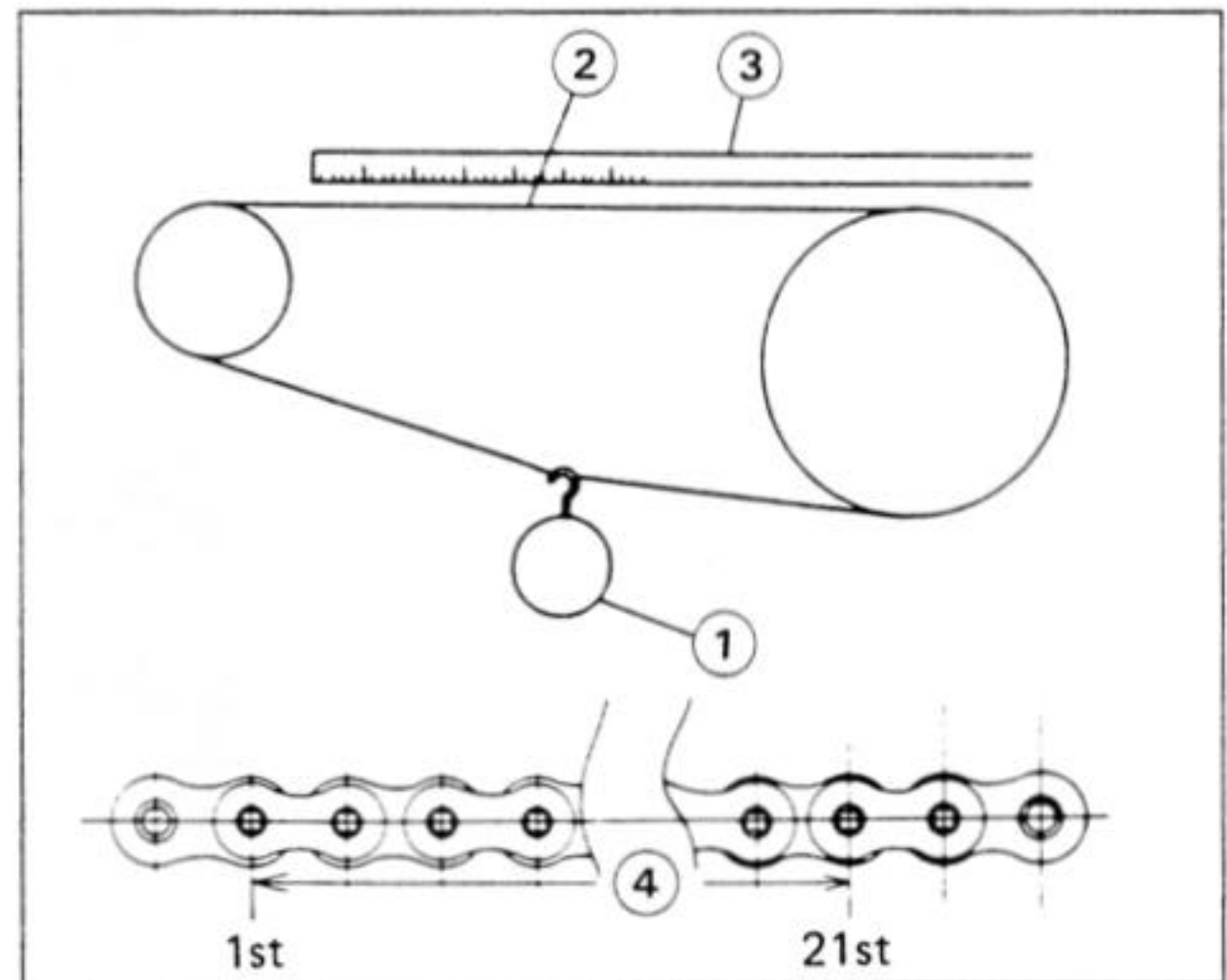

- 1. Weight
- 2. Straight Part
- 3. Ruler
- 4. Measure this length.

Drive Chain 20-Link Length

Standard: 317.5 ~ 318.4 mm
Service Limit: 323 mm

- ★ If any measurement exceeds the service limit, replace the chain. Also, replace the engine and rear sprockets when the drive chain is replaced.

⚠ WARNING

If the drive chain wear exceeds the service limit, replace the chain or an unsafe riding condition may result. A chain that breaks or jumps off the sprockets could snag on the engine sprocket or lock the rear wheel, severely damaging the motorcycle and causing it to go out of control.

Lubrication

- If a special lubricant is not available, a heavy oil such as SAE 90 is preferred to a lighter oil because it will stay on the chain longer and provide better lubrication.
- If the chain appears especially dirty, it should be cleaned before lubrication.

CAUTION

The O-rings between the side plates seal in the lubricant between the pin and the bushing. To avoid damaging the O-rings and resultant loss of lubricant, observe the following rules.
Use only kerosene or diesel oil for cleaning an O-ring drive chain. Any other cleaning solution such as gasoline or trichloroethylene will cause deterioration and swelling of the O-rings.
Immediately blow the chain dry with compressed air after cleaning.
Complete cleaning and drying the chain within 10 minutes.

10-6 FINAL DRIVE

- Apply oil to the sides of the rollers so that oil will penetrate to the rollers and bushings. Apply the oil to the O-rings so that the O-rings will be coated with oil.
- Wipe off any excess oil.

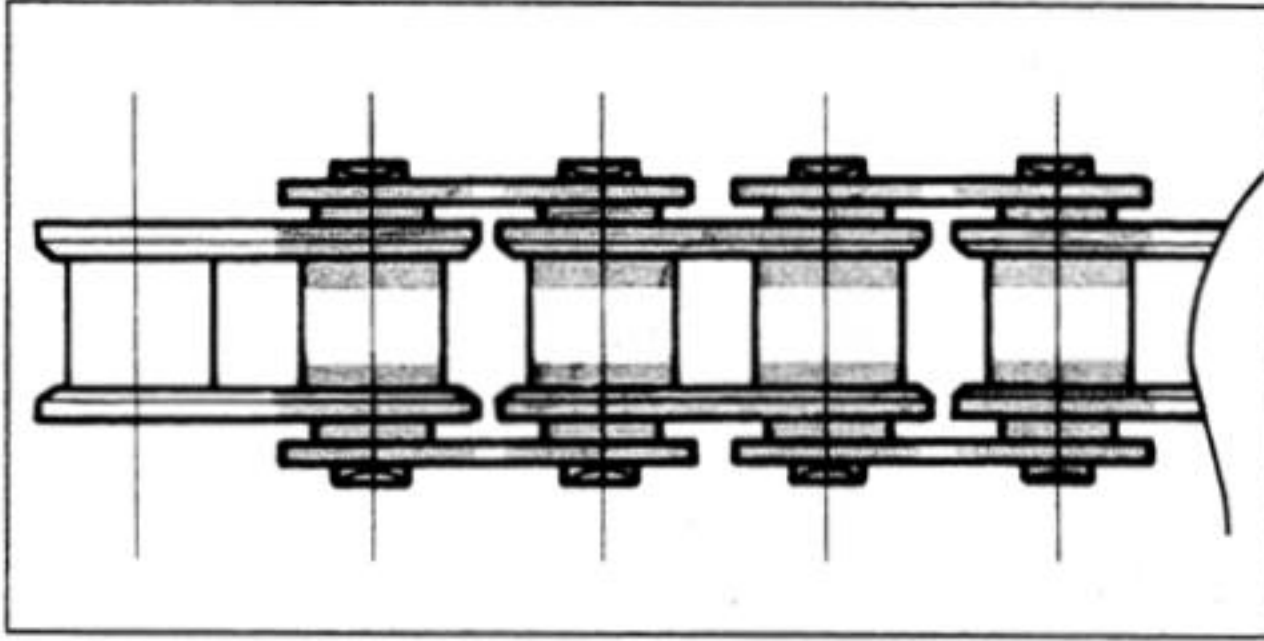

■ : Oil Applied Areas

Brakes

Table of Contents

Exploded View	11-2
Specifications	11-4
Special Tools	11-4

11-2 BRAKES

Exploded View

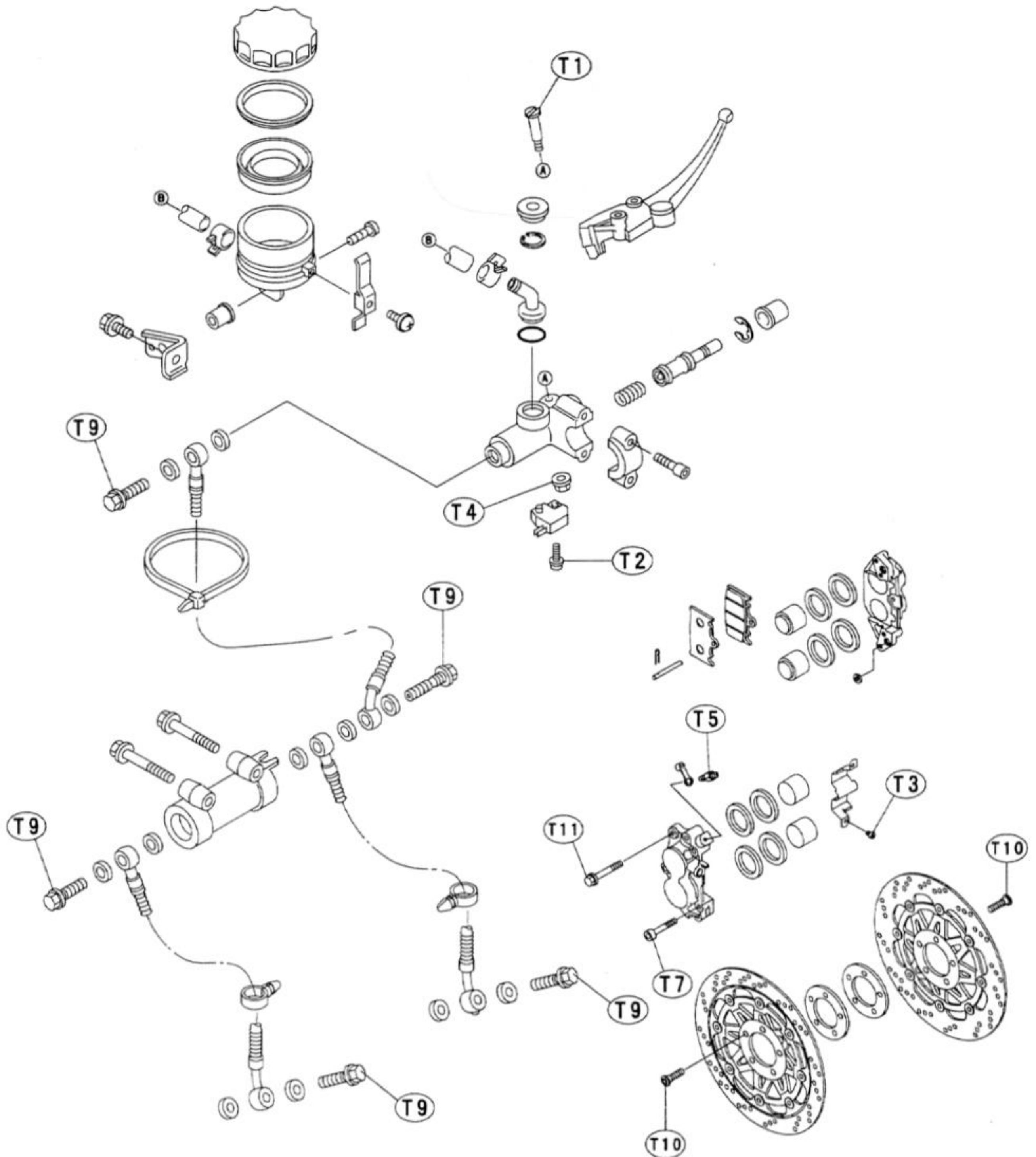

ZX400L02W4 C

T1 : 1.0 N-m (0.10 kg-m, 9 in-lb)
T2 : 1.2 N-m (0.12 kg-m, 10 in-lb)
T3 : 2.9 N-m (0.3010 kg-m, 26 in-lb)
T4 : 5.91.0 N-m (0.60 kg-m, 52 in-lb)
T5 : 7.8 N-m (0.80 kg-m, 69 in-lb)
T6 : 18 N-m (1.8 kg-m, 13.0 ft-lb)
T7 : 21 N-m (2.1 kg-m, 15.0 ft-lb)

T8 : 23 N-m (2.3 kg-m, 16.5 ft-lb)
T9 : 25 N-m (2.5 kg-m, 18.0 ft-lb)
T10 : 27 N-m (2.8 kg-m, 20 ft-lb)
T11 : 32 N-m (3.3 kg-m, 24 ft-lb)
T12 : 34 N-m (3.5 kg-m, 25 ft-lb)

G : Apply grease.

M : Apply molybdenum disulfide grease.

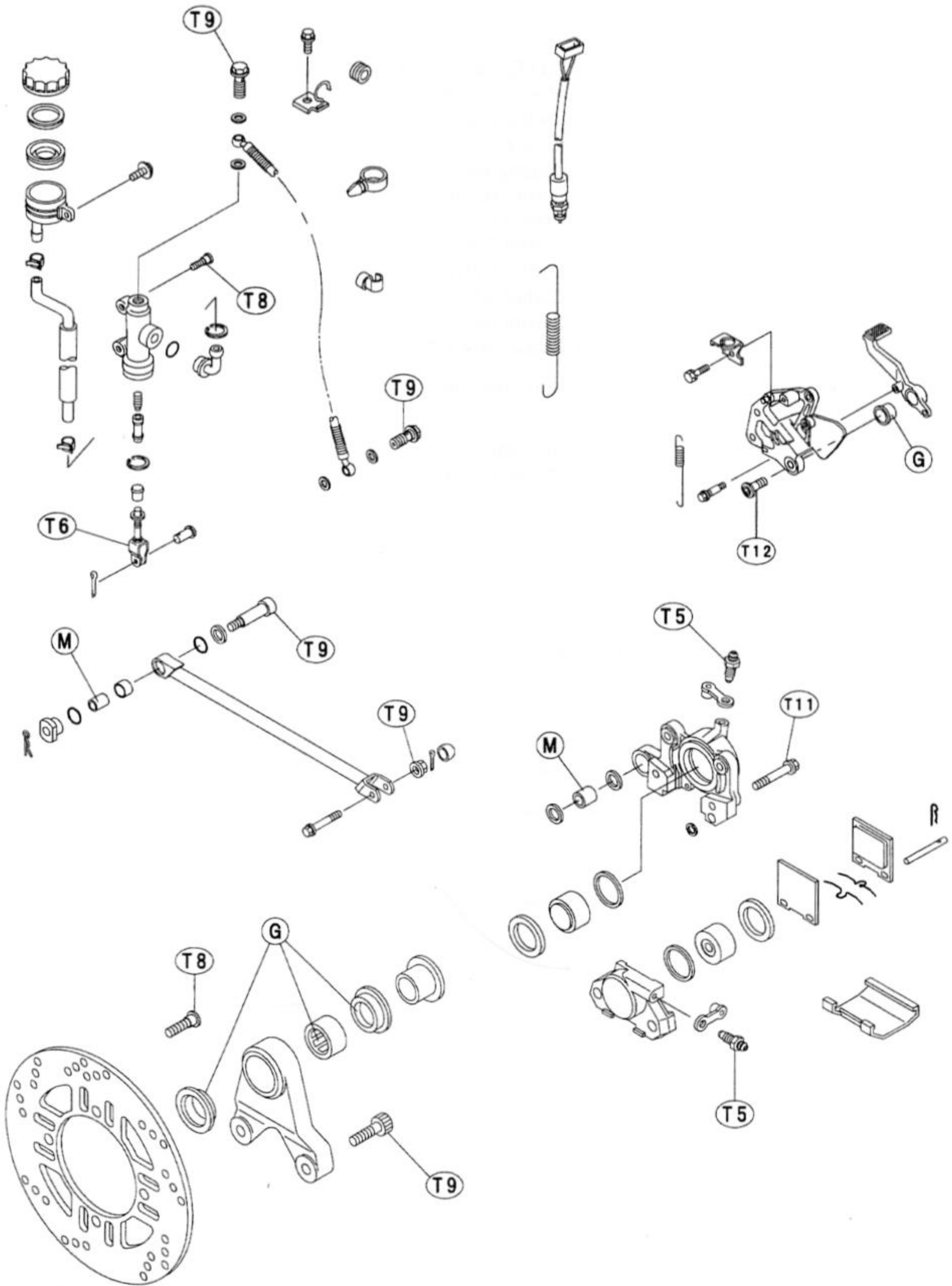

11-4 BRAKES

Specifications

Item	Standard	Service Limit
Brake Fluid: Grade Brand (recommended):	D.O.T.3 or D.O.T.4 Atlas Extra Heavy Duty Shell Super Heavy Duty Texaco Super Heavy Duty Wagner Lockheed Heavy Duty Castrol Girling-Universal Castrol GT (LMA) Castrol Disc Brake Fluid Castrol Girling, Universal Castrol GT (LMA) Castrol Disc Brake Fluid Check Shock Premium Heavy Duty	--- --- --- --- --- --- --- --- --- ---
Brake Lever Free Play:	Non-adjustable	---
Brake Pedal: Brake pedal free play Brake pedal position	Non-adjustable 43 mm below from center of brake pedal shaft	--- ---
Brake Light Switch: Front Rear	Non-adjustable On after about 10 mm pedal travel	--- ---
Brake Pad Lining Thickness: Front Rear	4 mm 4 mm	1 mm 1 mm
Brake Disc: Disc thickness: Front Rear Disc runout	3.8 ~ 4.1 mm 5.8 ~ 6.1 mm 0.2 mm or under	3.5 mm 5.5 mm 0.3 mm

Special Tools

Jack: 57001-1238

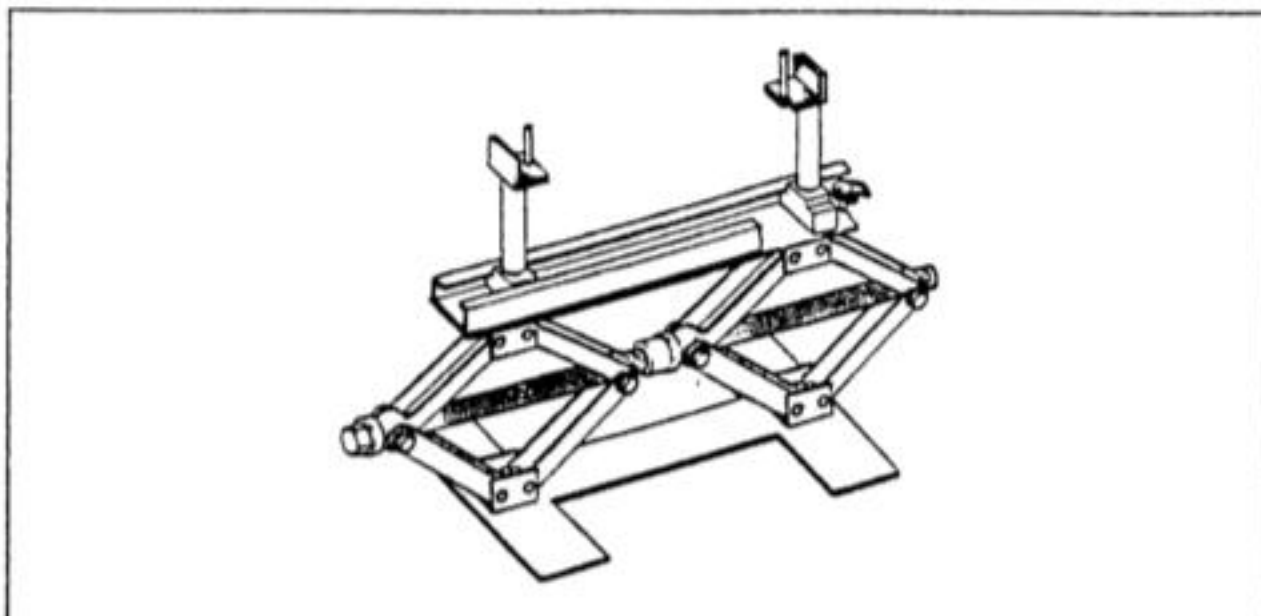

Inside Circlip Pliers: 57001-143

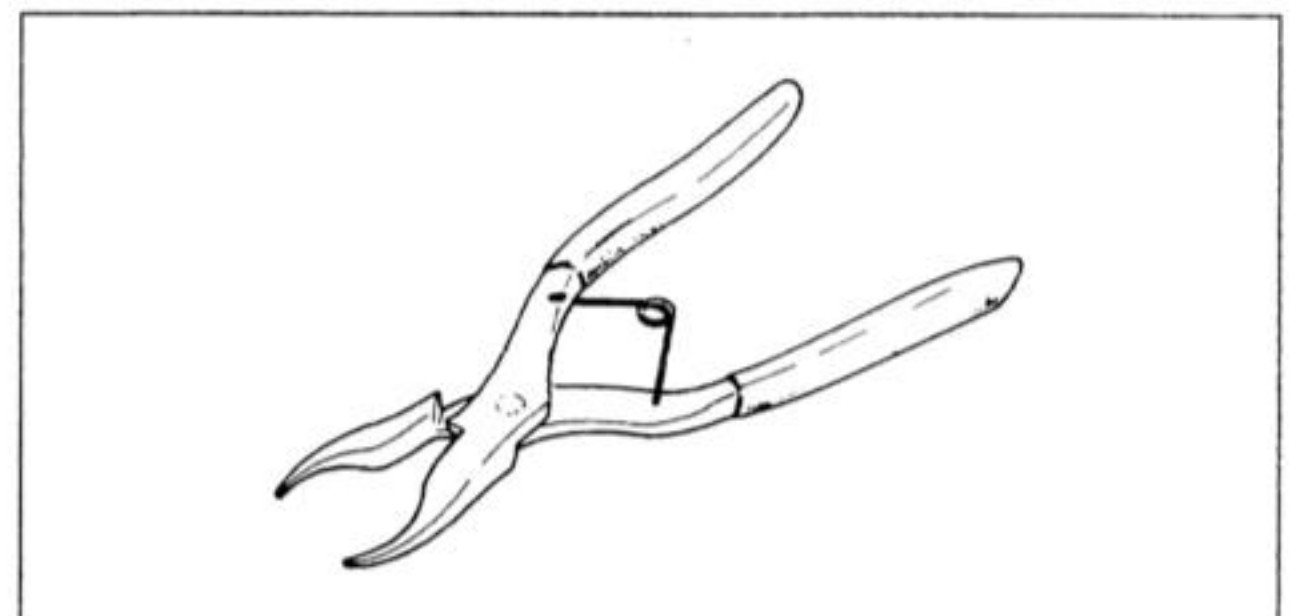

Suspension

Table of Contents

Exploded View	12-2
Specifications	12-4
Special Tools	12-5
Front Fork	12-6
Fork Oil Change	12-6
Disassembly (for each leg)	12-9
Assembly	12-10
Inner Tube Inspection	12-10
Oil Seal and Dust Seal Inspection	12-11
Spring Tension.....	12-11

12-2 SUSPENSION

Exploded View

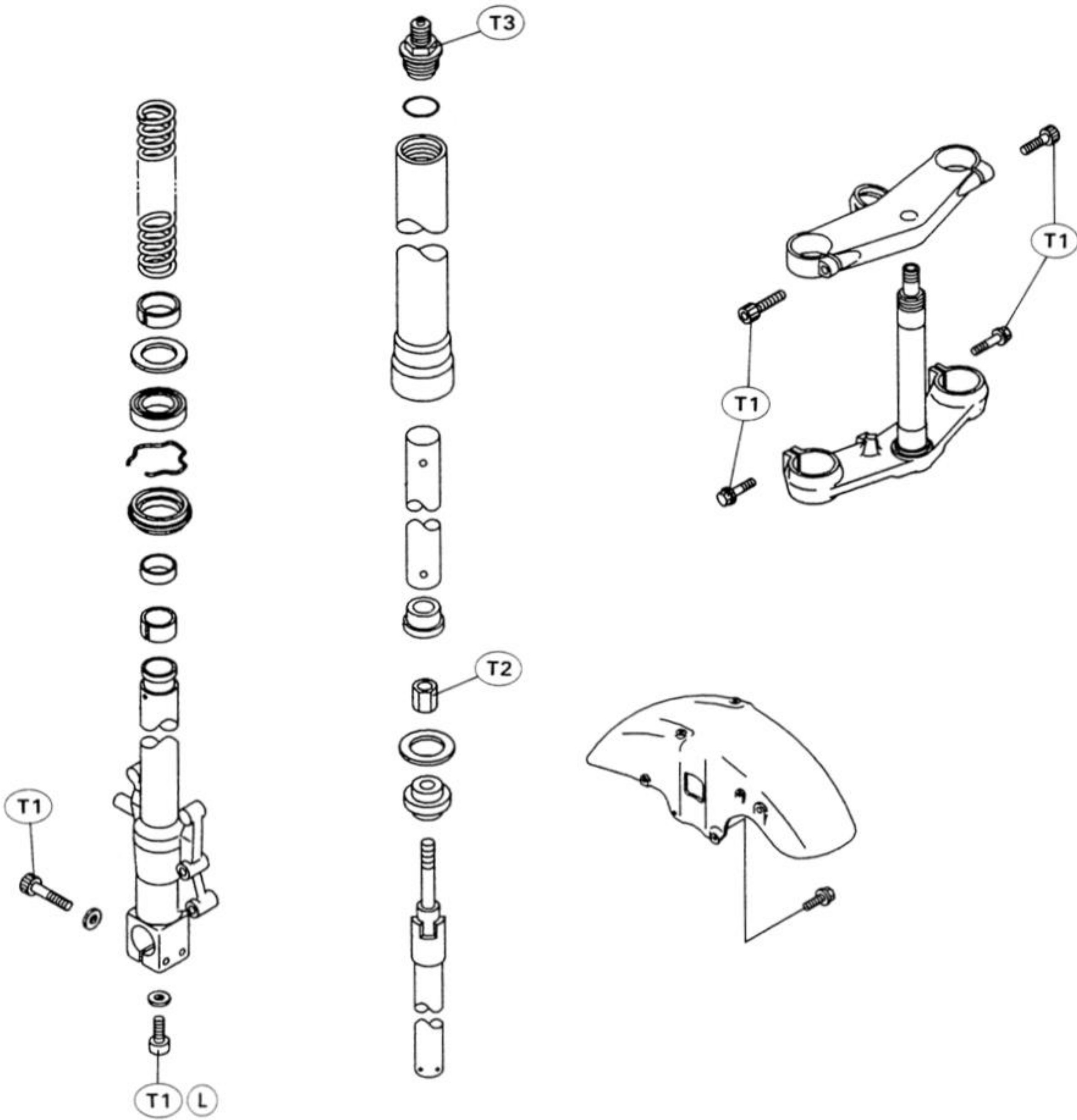

T1 : 20 N-m (2.0 kg-m, 14.5 ft-lb)

T2 : 25 N-m (2.5 kg-m, 18 ft-lb)

T3 : 34 N-m (3.5 kg-m, 25 ft-lb)

T4 : 49 N-m (5.0 kg-m, 36 ft-lb)

T5 : 88 N-m (9.0 kg-m, 65 ft-lb)

T6 : 110 N-m (11.0 kg-m, 80 ft-lb)

M : Apply molybdenum disulfide grease.

L : Apply a non-permanent locking agent to the threads.

SUSPENSION 12-3

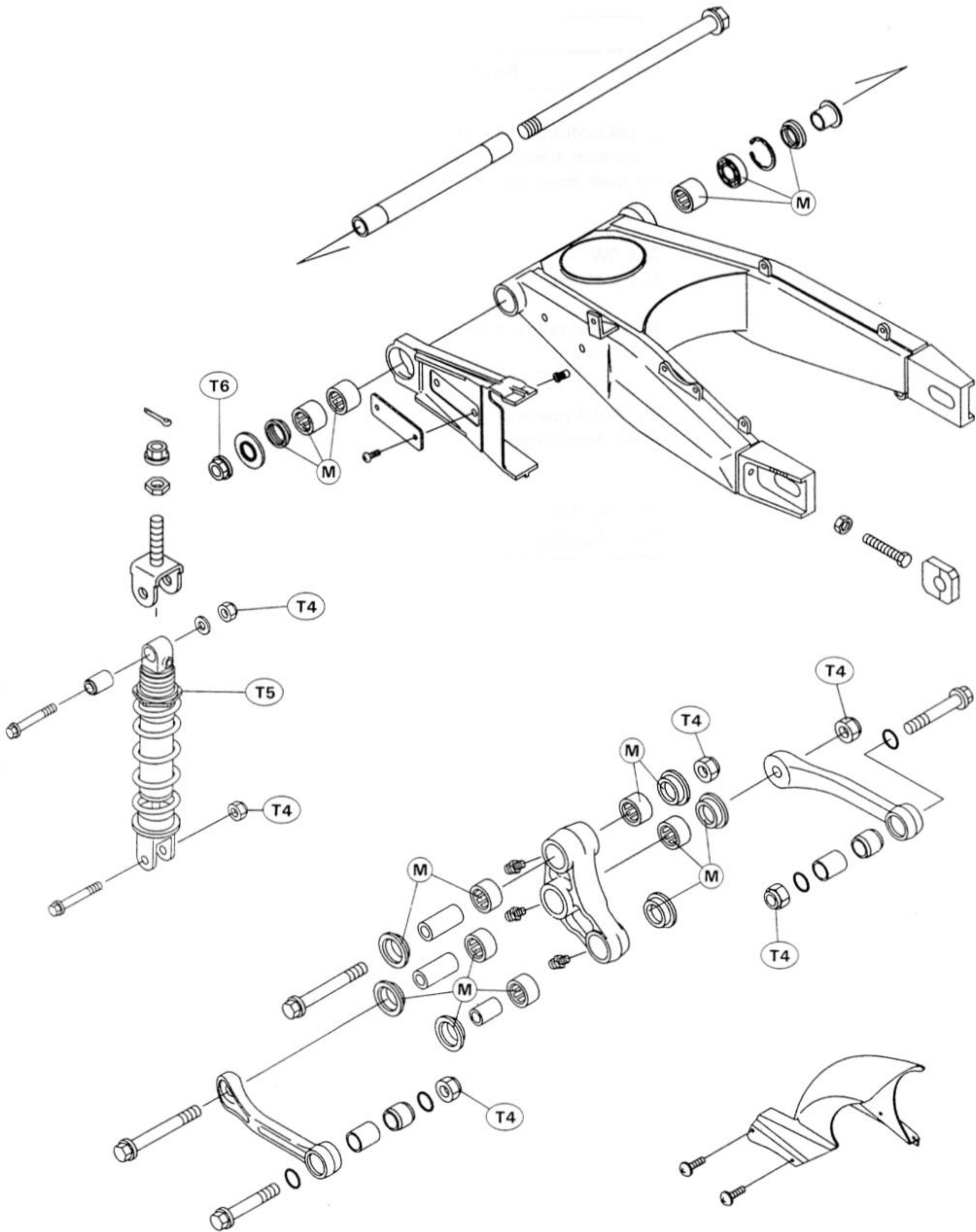

12-4 SUSPENSION

Specifications

Item	Standard	Service Limit
Front Fork: Rebound damping setting Spring preload setting Fork oil: Viscosity Amount (per side) Oil level (fully compressed, with spring) Fork spring free length	6 clicks counterclockwise (from the seated position adjuster turned fully clockwise) 6th mark from the top SAE 5W 424 ±2.5 mL 85 ±8 mm below from top of outer tube 325.1 mm	(adjustable range) 12 clicks (adjustable range) 7 marks - - - - - - - - - 319 mm
Rear Shock Absorber: Rebound damping setting Spring preload setting Gas pressure	No. 2 of 4 position Spring free length minus 6.5 mm 980 kPa (10 kg/cm ² , 142 psi) Non-adjustable	- - - Spring free length minus 6.5 mm to 24.5 mm - - -

Special Tools

Steering Stem Nut Wrench: 57001-1100

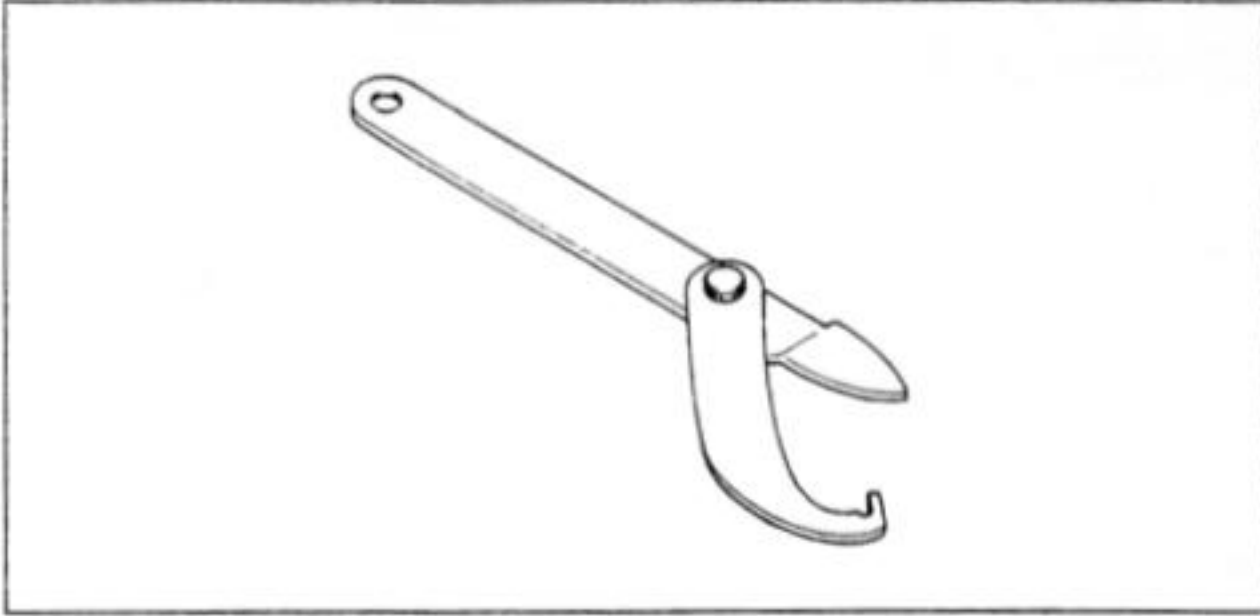

Fork Oil Level Gauge: 57001-1290

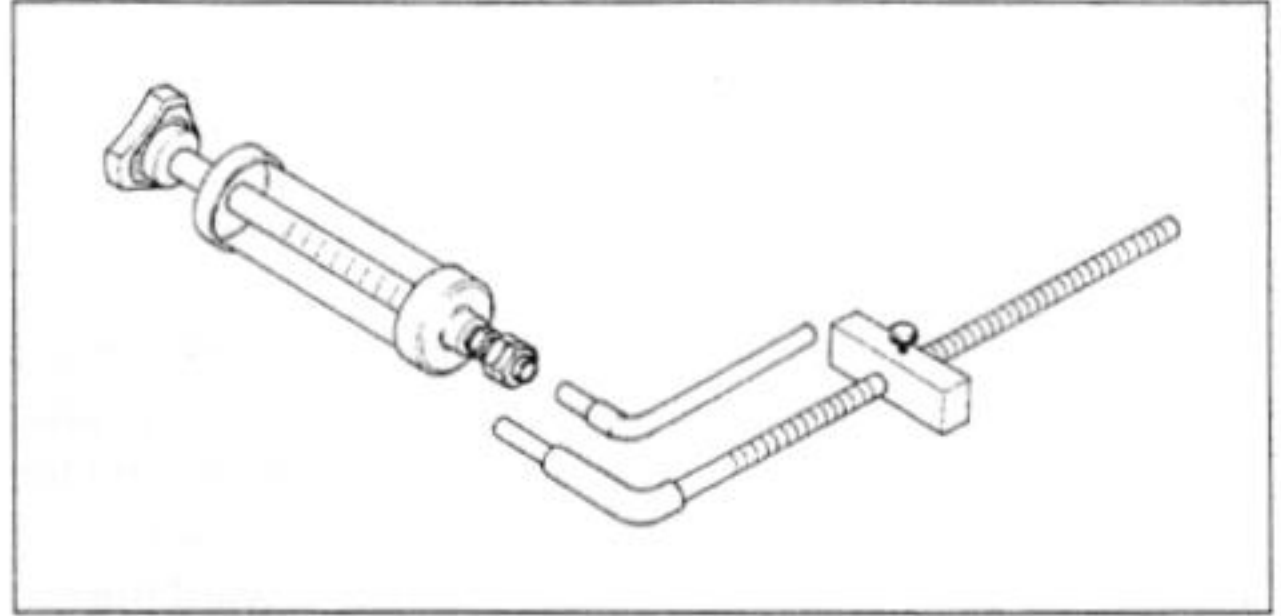

Bearing Driver Set: 57001-1129



Fork Piston Rod Puller, M10 x 1.0: 57001-1298

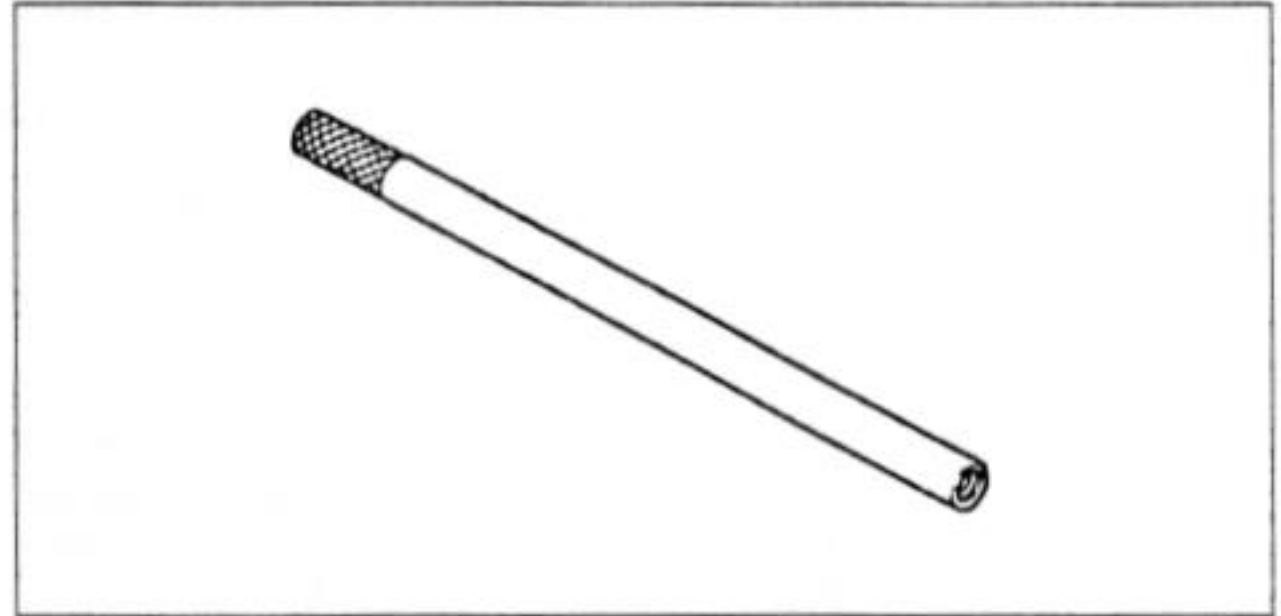

Fork Outer Tube Weight: 57001-1218

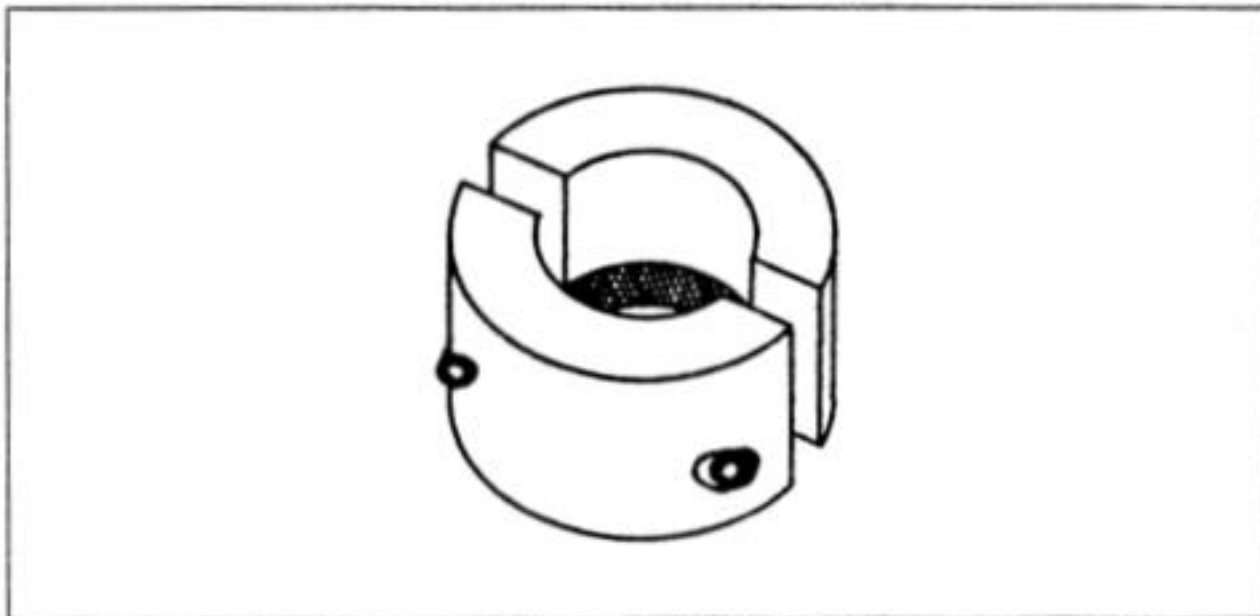

Fork Spring Compressor: 57001-1338

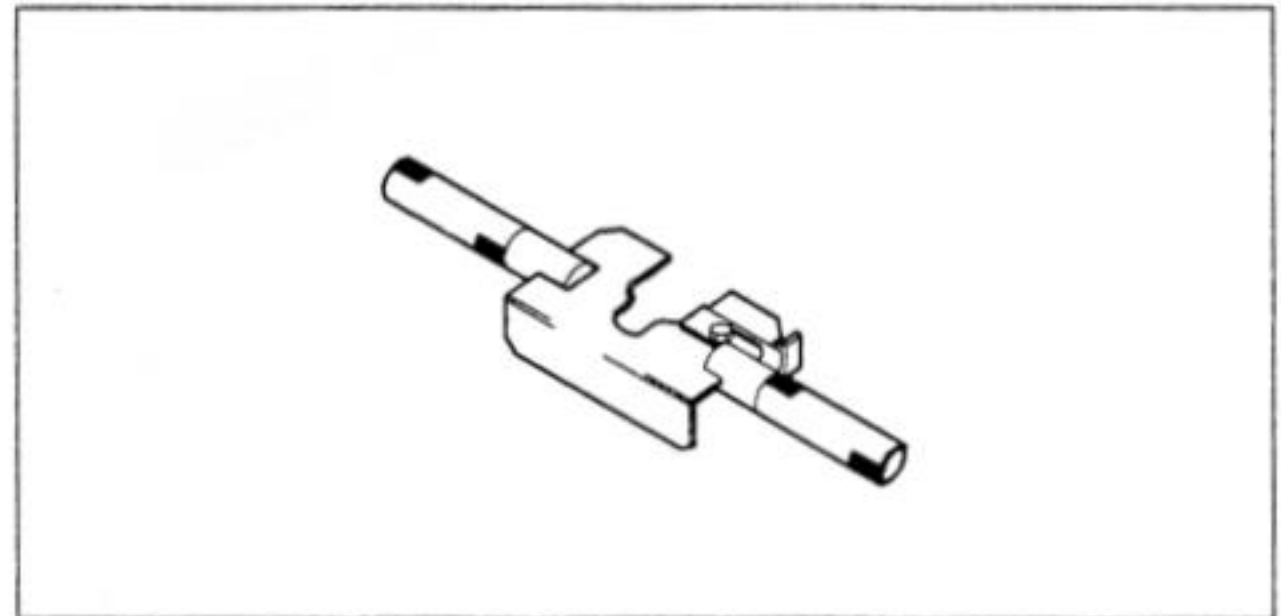

Jack: 57001-1238

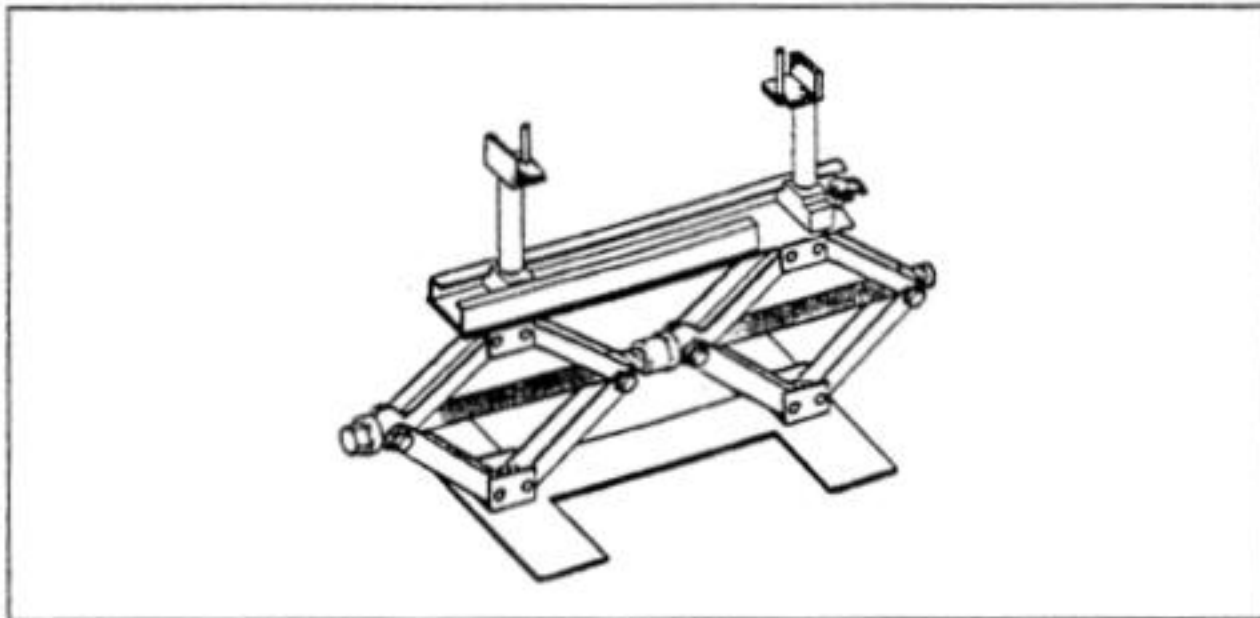

Oil Seal & Bearing Remover: 57001-1058

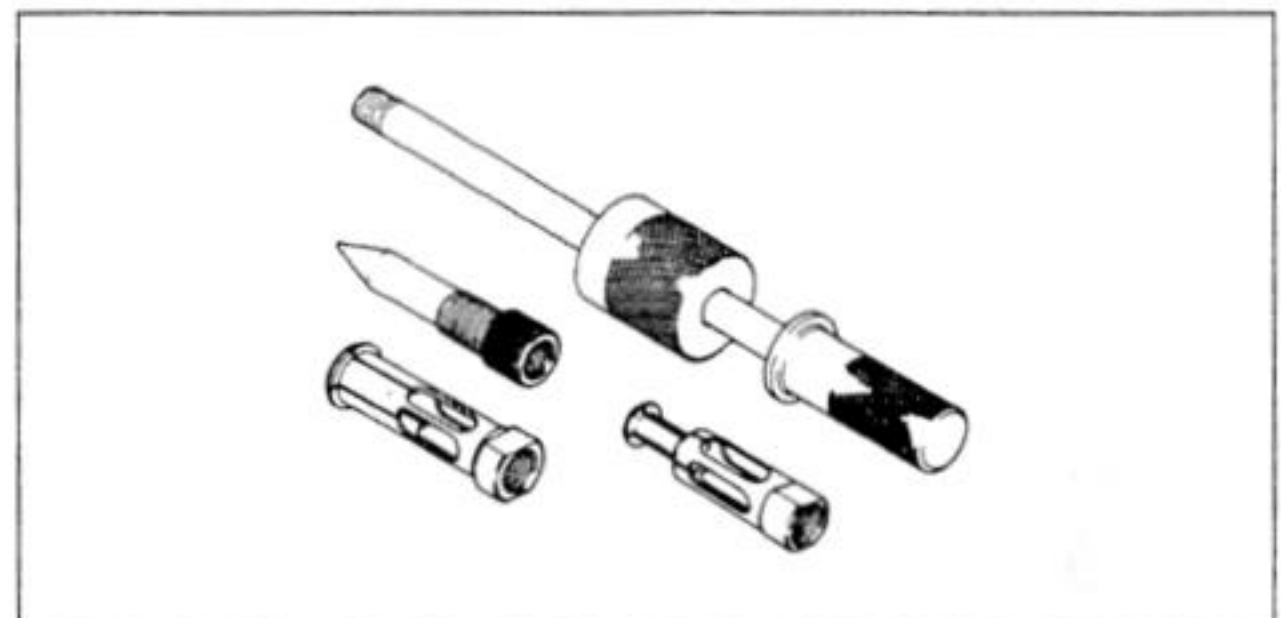

Fork Oil Seal Driver: 57001-1288

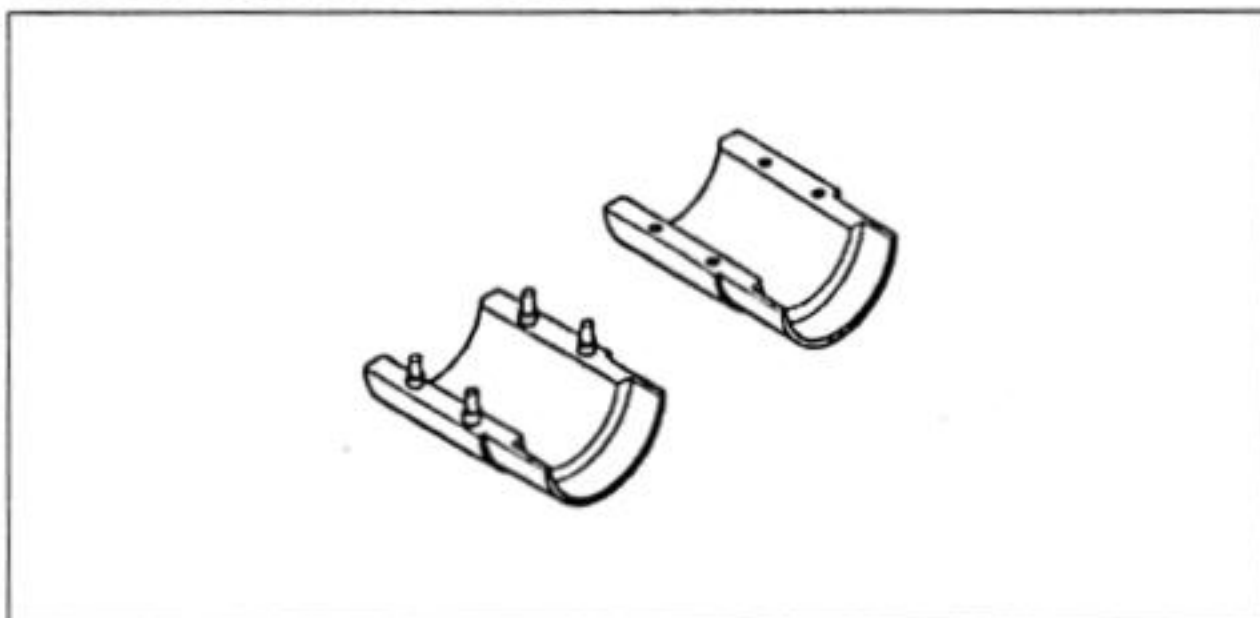

12-6 SUSPENSION

Front Fork

Fork Oil Change

- Loosen the fork top plug temporarily.
- Remove the front fork.
- Hold the fork tube vertically in a vise.
- Remove the fork top plug from the outer tube.
- Compress the fork.
- To loosen the piston rod nut, fit the fork spring compressor (special tool) between the fork top plug and the spring seat, then press the collar down until the compressor has just gone past the piston rod nut.
- At this point push the compressor further toward the rod to fit it fully on the rod nut bottom.
- Slide in the stopper of the compressor as far as it goes to secure the compressor.

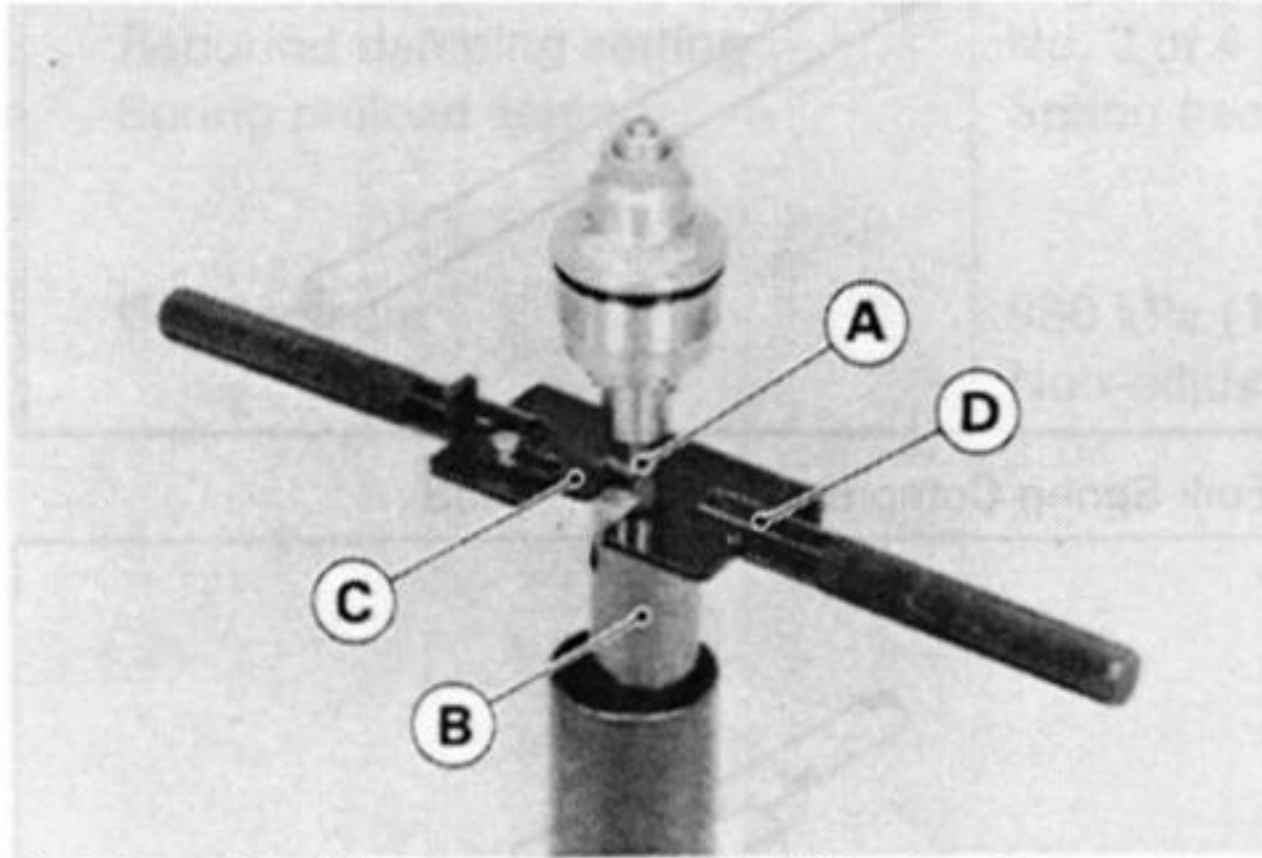

A. Piston Rod Nut
B. Collar
C. Stopper
D. Fork Spring Compressor: 57001-1338

- Use wrenches on the piston rod nut and the top plug to loosen the piston rod nut.

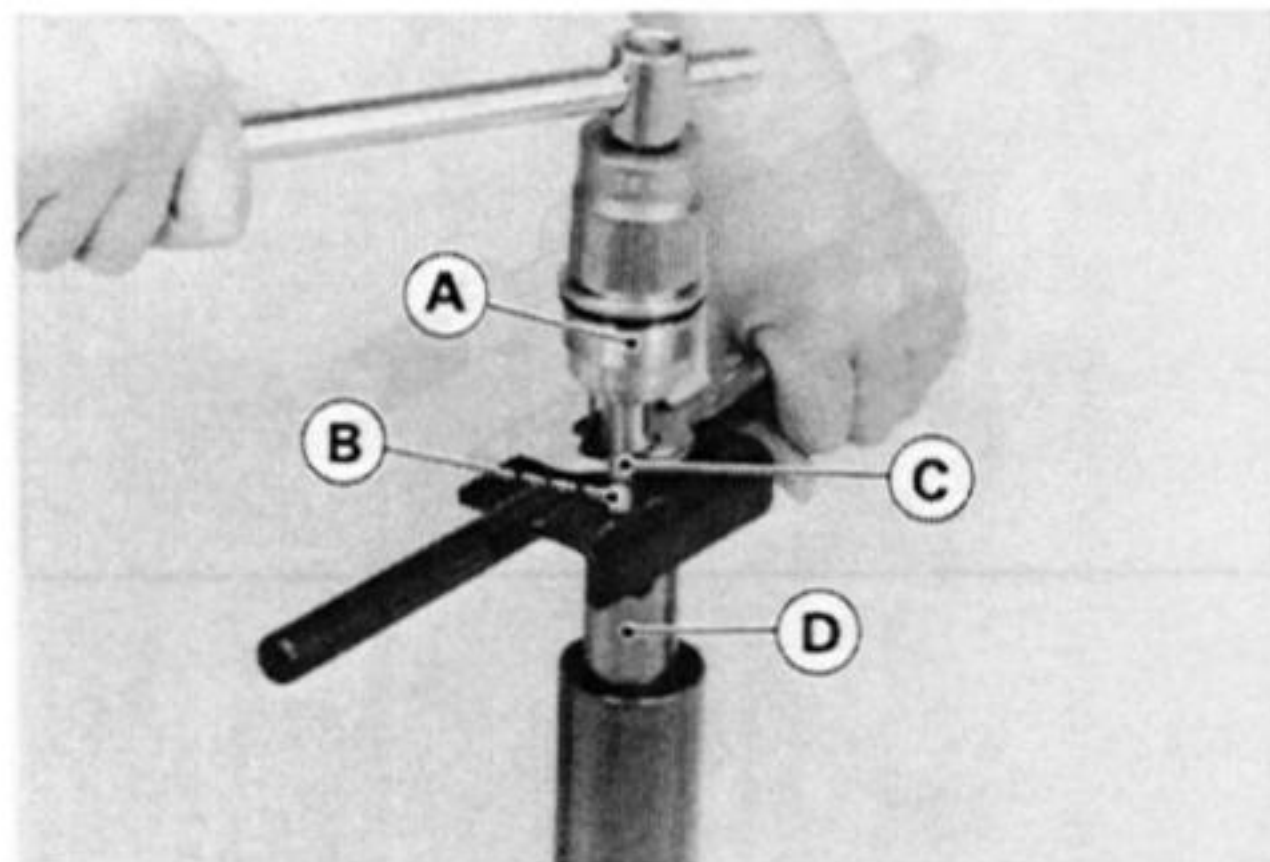

A. Top Plug
B. Spring Seat
C. Piston Rod Nut
D. Collar

- Remove the top plug from the piston rod.
- Slide out the stopper of the compressor.
- Remove the compressor from the piston rod with the following procedures.

- To make free the piston rod nut from the compressor, push back the compressor until the nut positions in the wide slot of the compressor.

⚠ WARNING

To avoid serious injury, never take out the compressor from the fork tube or at one procedure, the spring seat and spring guide will jump out of the piston rod causing crush your face or body.

- Lift up the compressor slowly on the piston rod and take it out from the fork tube.
- Remove the spring seat, spring guide and collar.

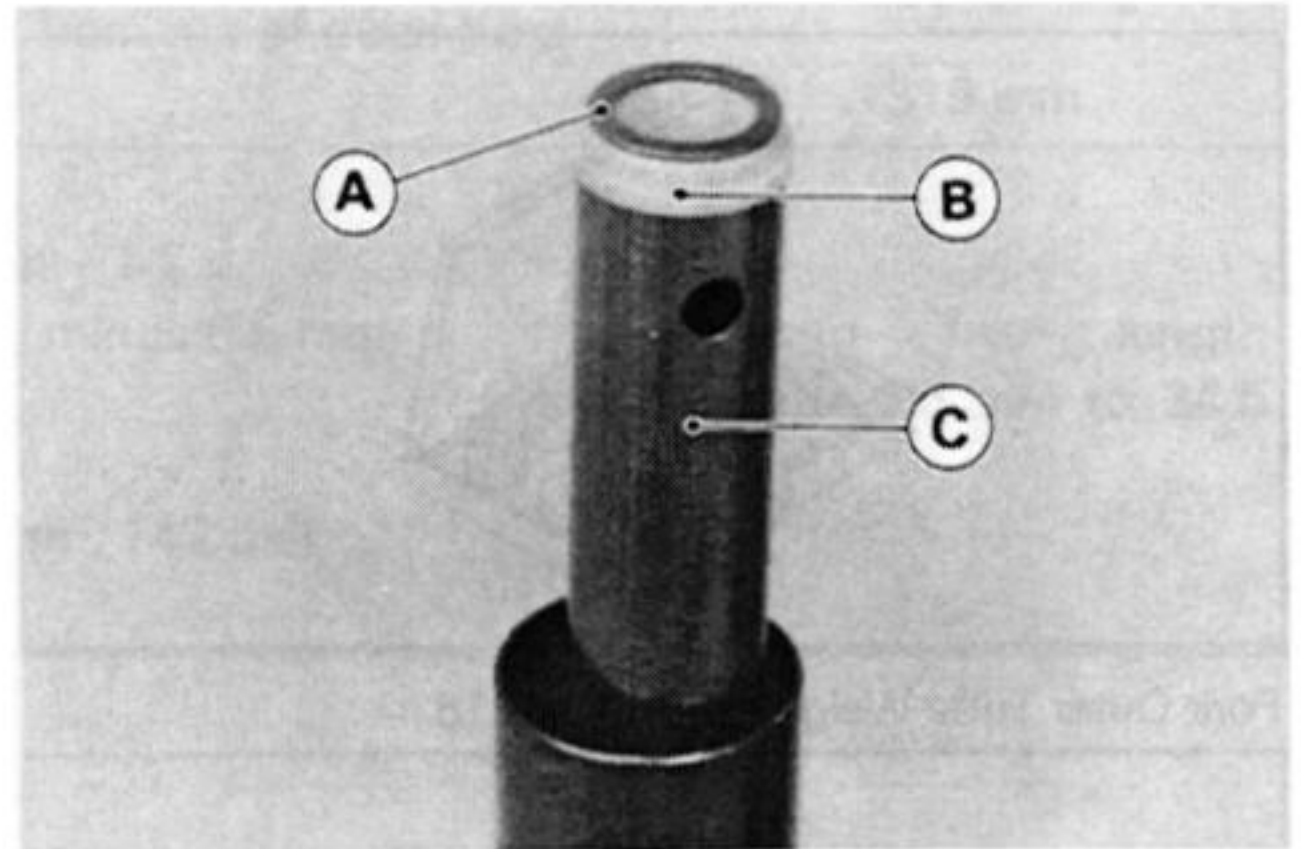

A. Spring Seat
B. Spring Guide
C. Collar

- Hold the fork tube upside down over a clean container and pump it to drain the oil.
- The main spring will come out at this time.
- Remove the main spring.

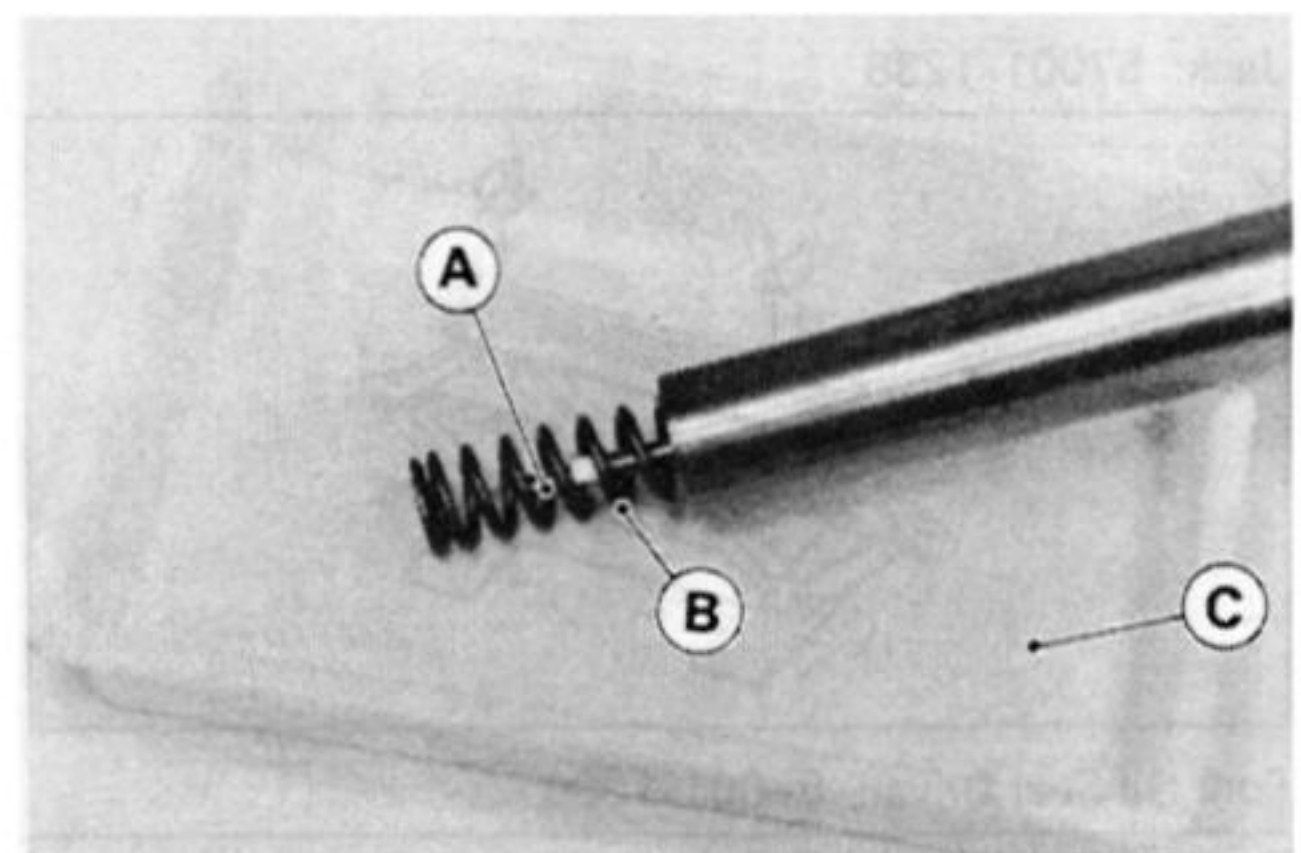

A. Push Rod
B. Main Spring
C. Container

NOTE

- To discharge the fork oil, pump the piston rod up and down at least ten times.
- Pull the piston rod up above the outer tube top.
- Tighten the piston rod nut finger-tight.

- Check that the visible thread length is at least 16 mm, and the chamfered side is down.

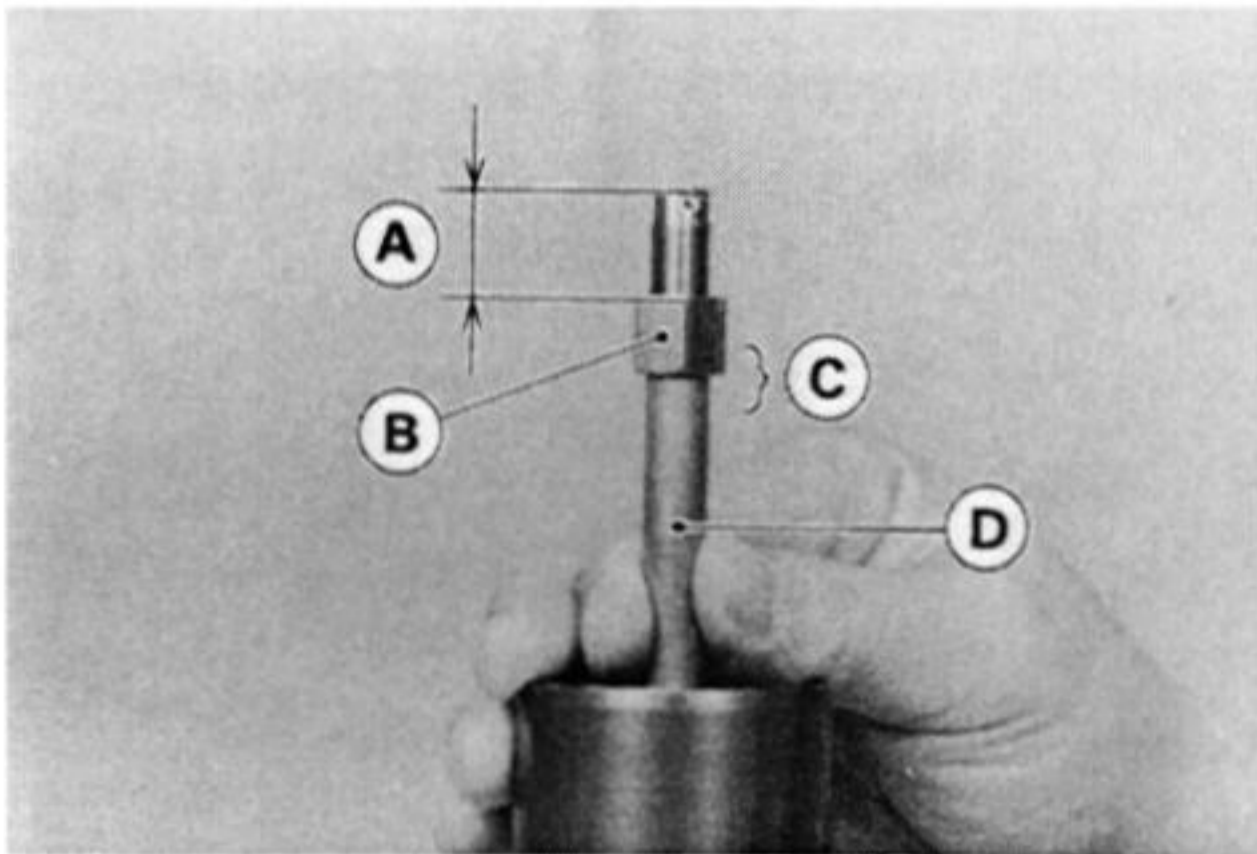

- A. 16 mm or more
- B. Piston Rod Nut
- C. Chamfered Side
- D. Piston Rod

- Install the main spring.
- Hold the fork tube upright, press the outer tube and the piston rod all the way down.
- Fill the front fork to the top with the specified oil which is more than the specified amount.

Front Fork Oil

Viscosity : SAE 5W
 Amount (per side) : 424 ±4 mL

NOTE

- While doing this, take care to keep the oil level topped off so that it stays above the four holes near the top of the inner tube.

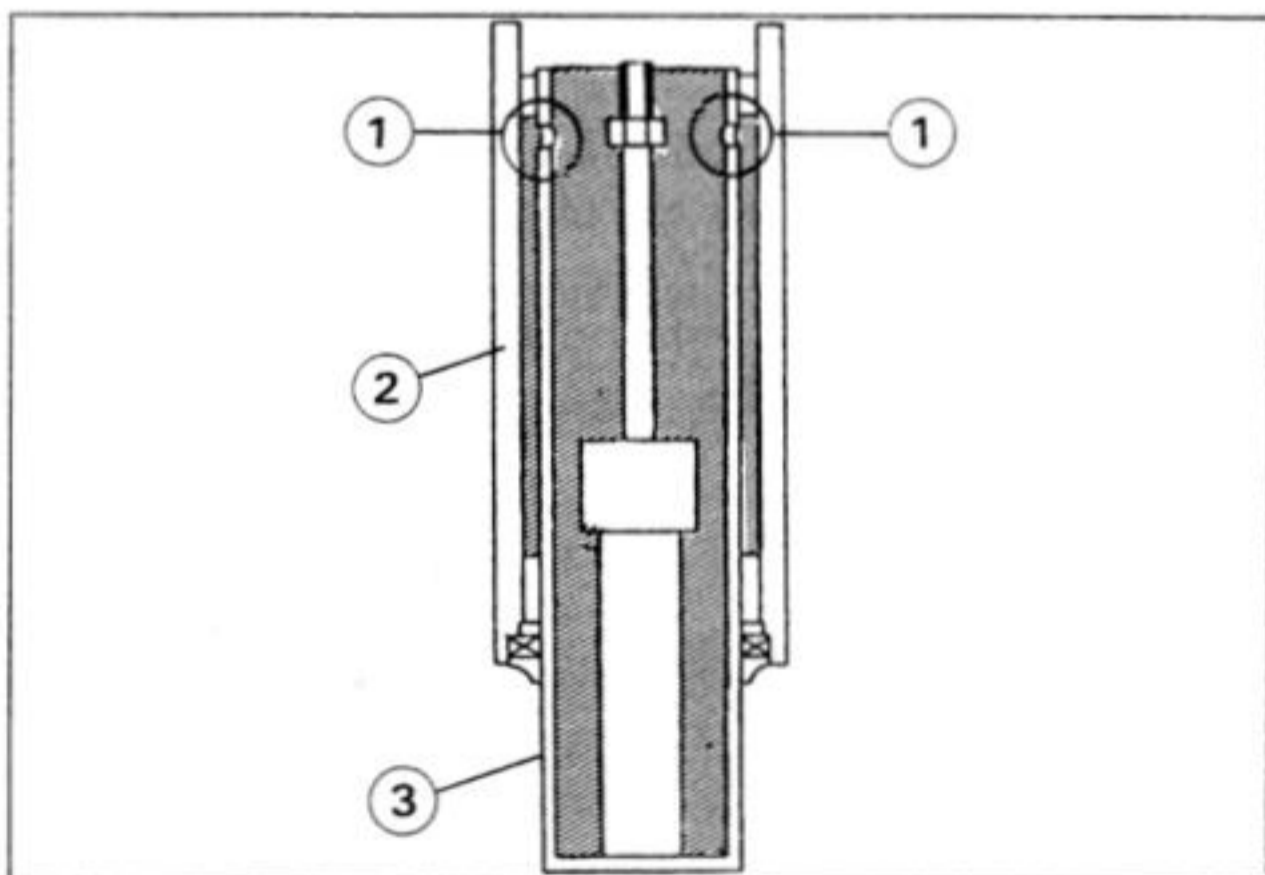

- 1. Holes
- 2. Outer Tube
- 3. Inner Tube

- Purge the air from the inner tube by gently moving the rod puller (special tool) up and down five times.

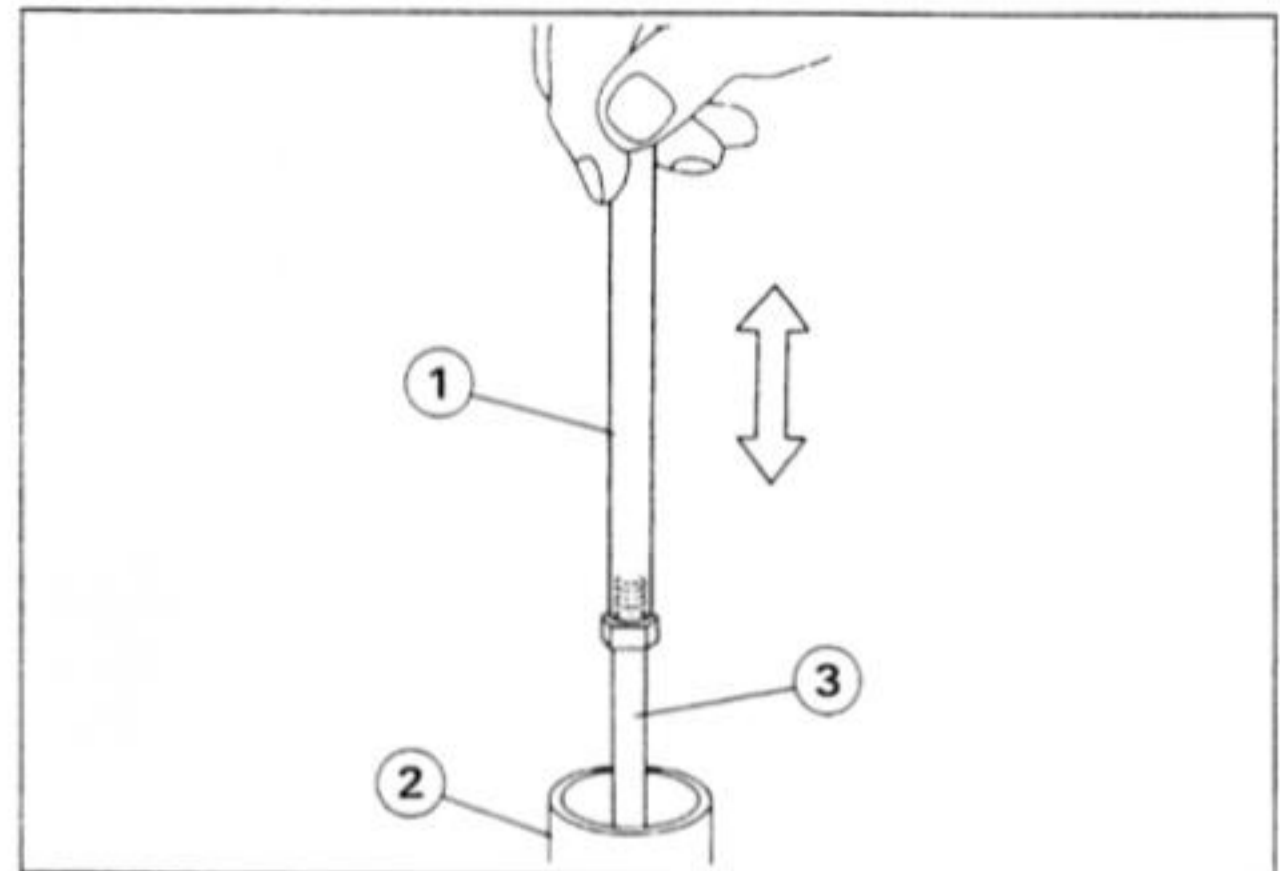

- 1. Piston Rod Puller: 57001-1298
- 2. Outer Tube
- 3. Piston Rod

- Purge the air from between the inner and outer tubes by pumping the outer tube up and down.

CAUTION

Never extend the fork fully, oil will be forced from between the tubes into the inner tube through the holes at the top of it. This raises the oil level in the inner tube. If the fork is extended to the full length of its normal travel, the oil level will be raised about 30 mm.

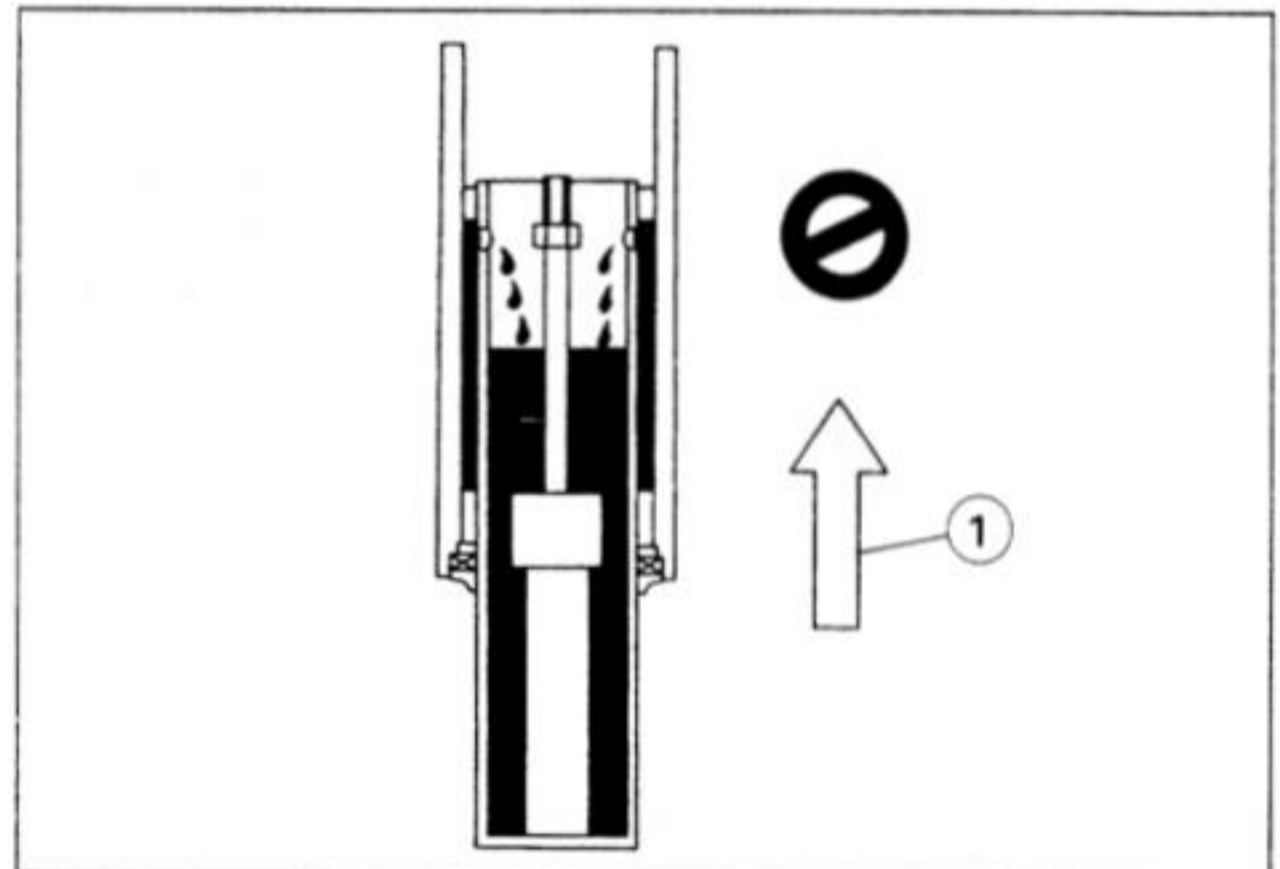

- 1. Never extend the fork fully.

- After purging the air from the fork, let it sit for about five minutes so that any suspended air bubbles can surface.
- Measure the oil level, using the fork oil level gauge (special tool).
- Set the gauge stopper so that its lower side shows the oil level distance specified.
- With the fork fully compressed, insert the gauge tube into the inner tube and position the stopper across the top of the outer tube.

12-8 SUSPENSION

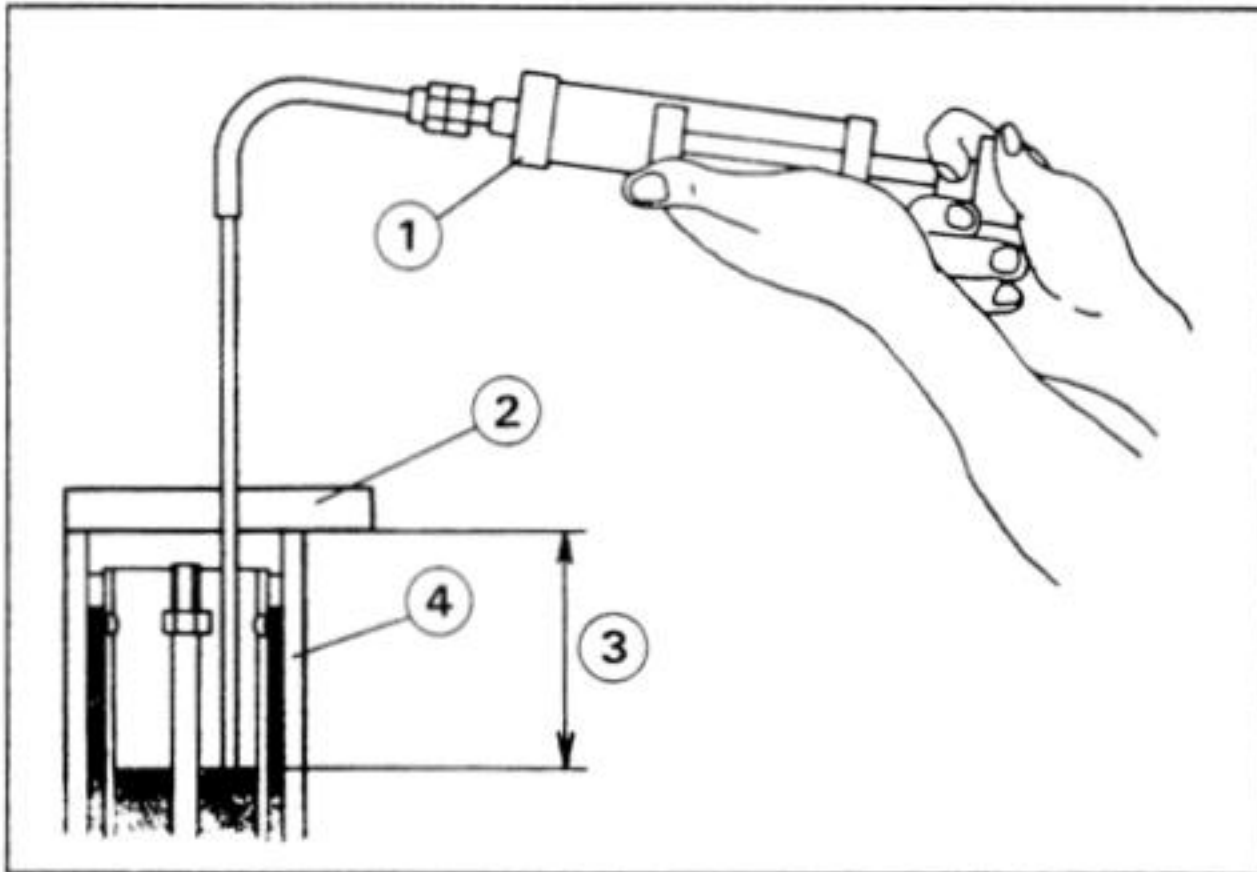

1. Level Gauge: 57001-1290 3. Oil Level Distance
2. Stopper 4. Outer Tube

NOTE

- The gauge tube is graduated in 1 cm division.
- The gauge body is graduated in 10 mL divisions, excluding the gauge tube capacity about 5 mL.
- Pull the handle slowly to draw out the excess oil until no more oil comes up the tube.
- ★ If no oil is drawn out, there is not enough oil in the fork. Pour in some more oil, then draw out the excess.

Fork Oil Level (Fully compressed with fork spring)

85 ± 8 mm

- ★ If the oil is above or below the specified level, remove or add oil and recheck the oil level.
- Screw the fork push rod puller (special tool) onto the end of the rod.
- Install the collar so that the resin bush side is down.

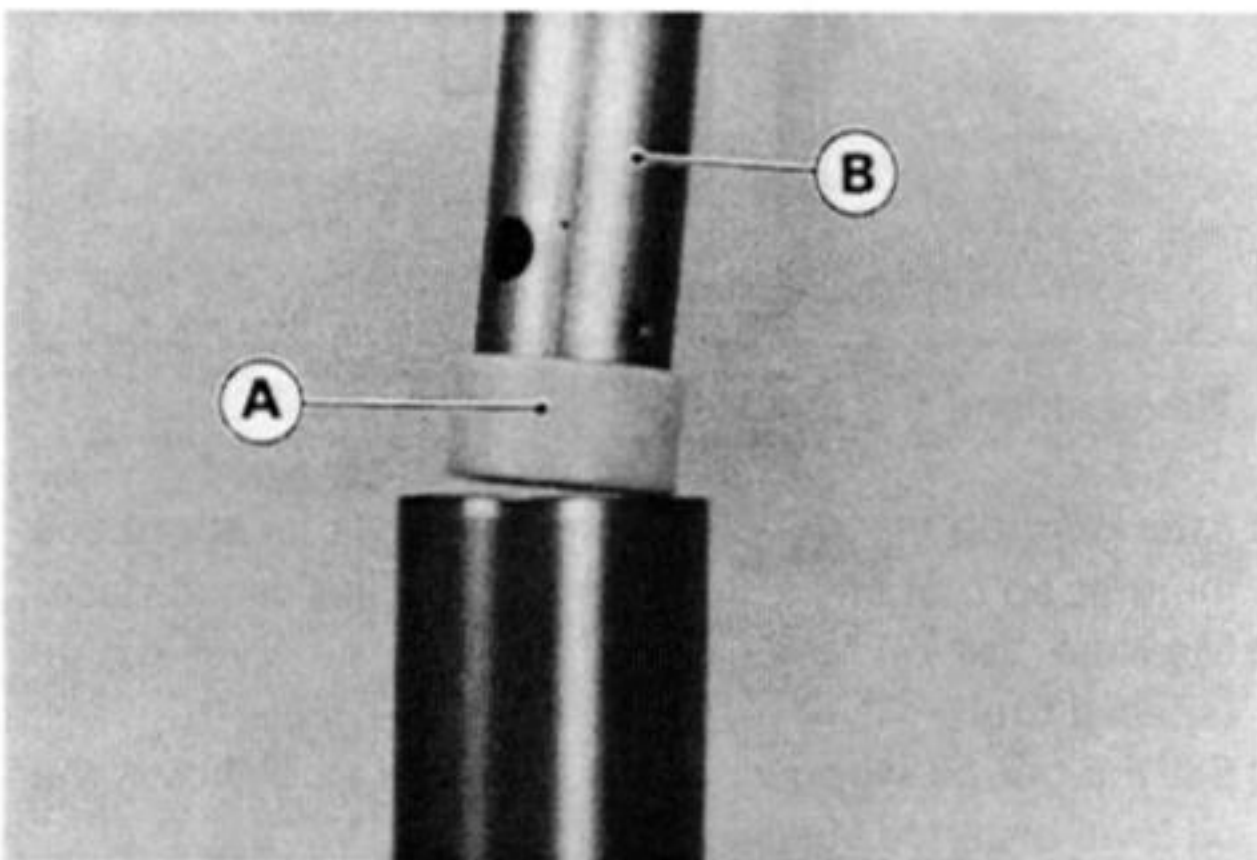

A. Resin Bush B. Collar

- Put the spring guide and spring seat on the collar.

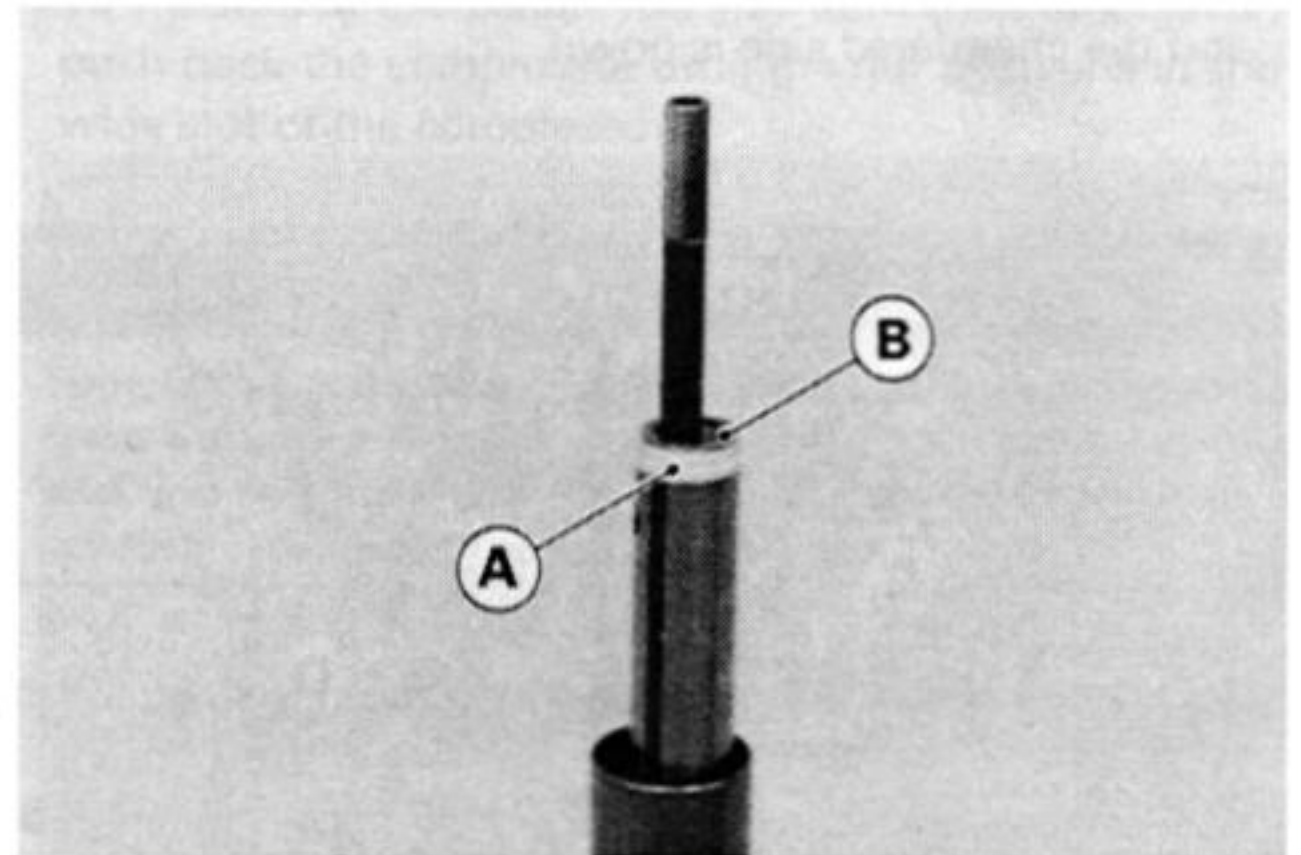

A. Spring Guide B. Spring Seat

- Using the fork spring compressor (special tool), press the collar down until the compressor has just gone past the piston rod nut.

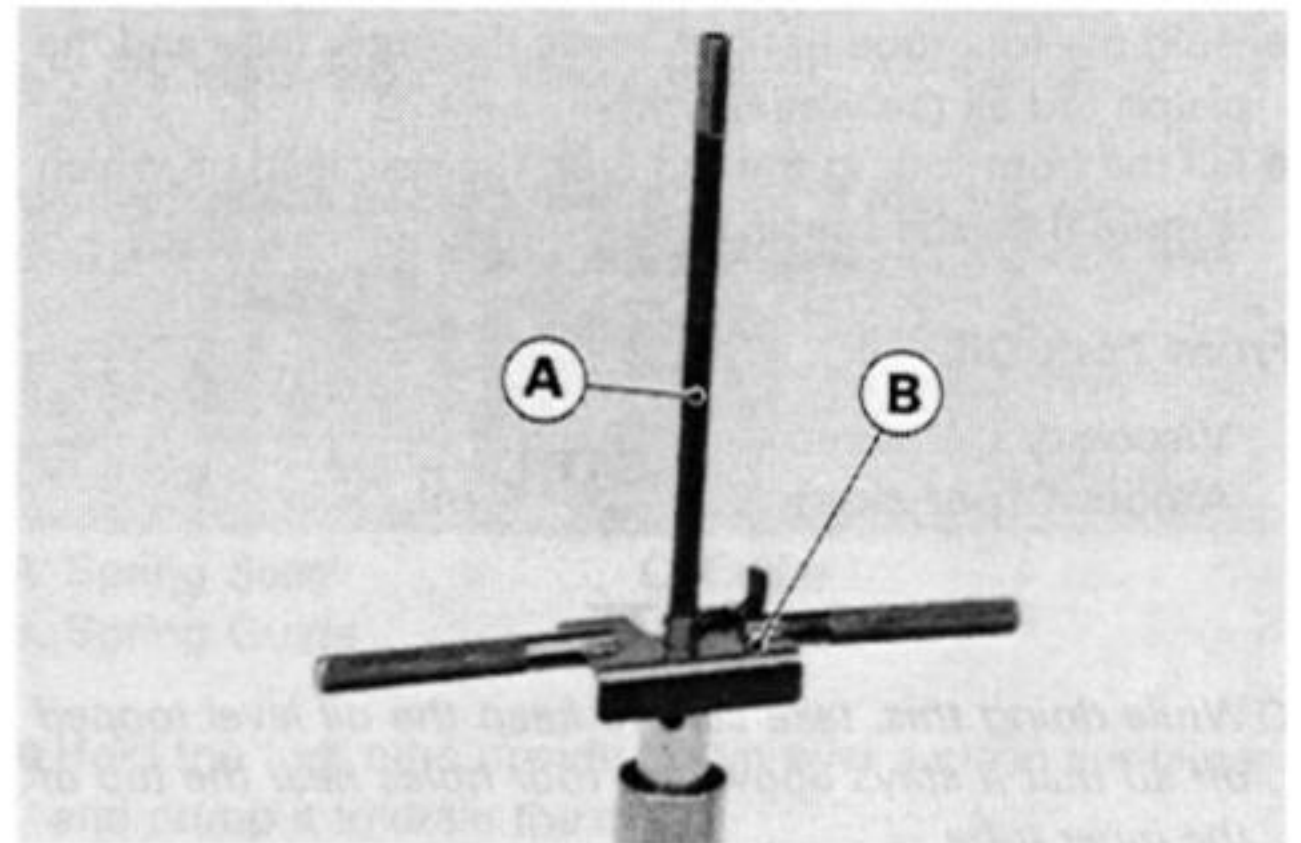

A. Fork Piston Rod Puller : 57001-1298
B. Fork Spring Compressor : 57001-1338

- Remove the fork push rod puller (special tool).
- Check the O-ring on the top plug, and replace it with a new one if damaged.
- Screw in the rebound damping adjuster of the top plug so that the adjuster is 1.5 mm above the top plug.

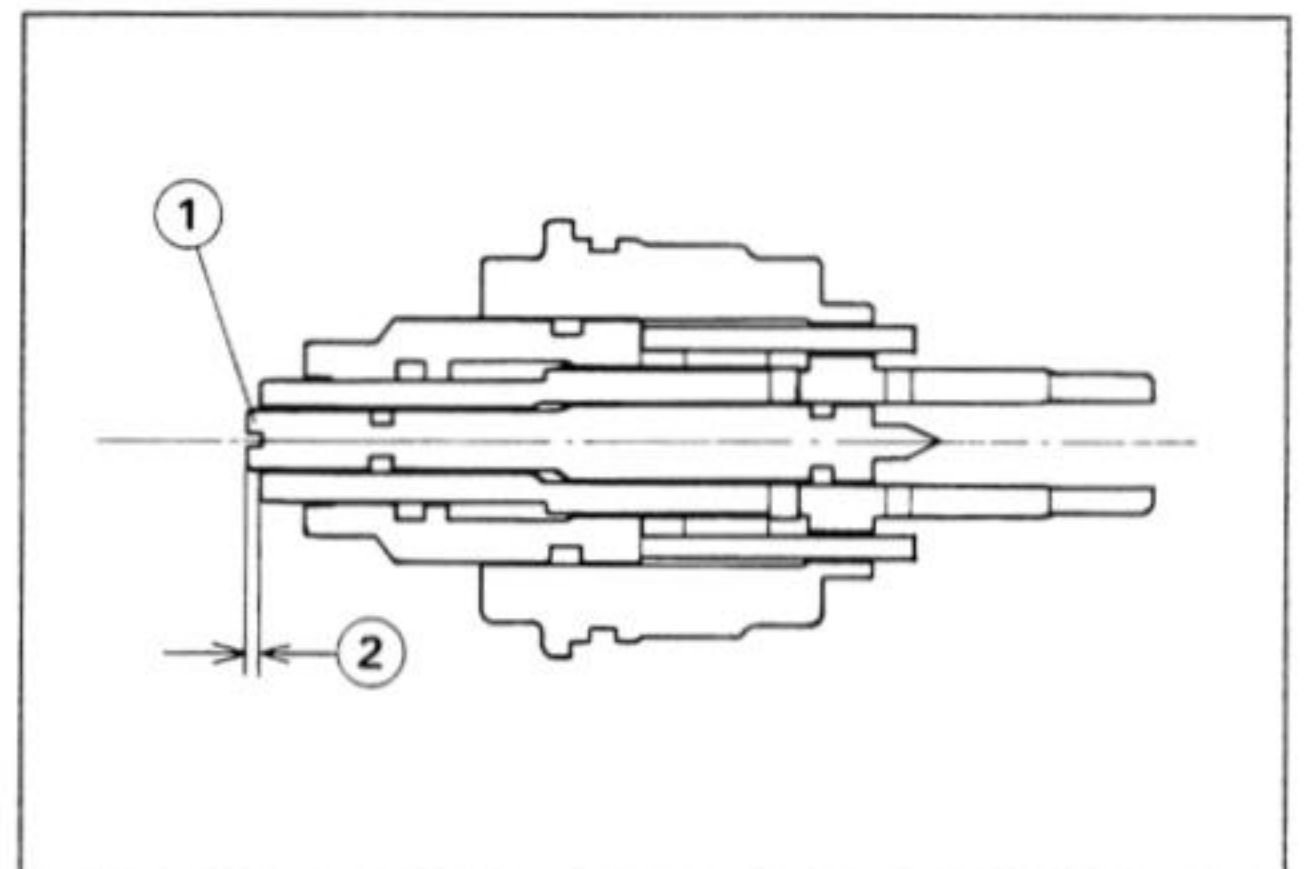

1. Rebound Damping Adjuster
2. 1.5 mm

- Tighten the top plug finger-tight.

SUSPENSION 12-9

- While holding the fork top plug, tighten the piston rod nut against the plug to the specified torque (see Exploded View).

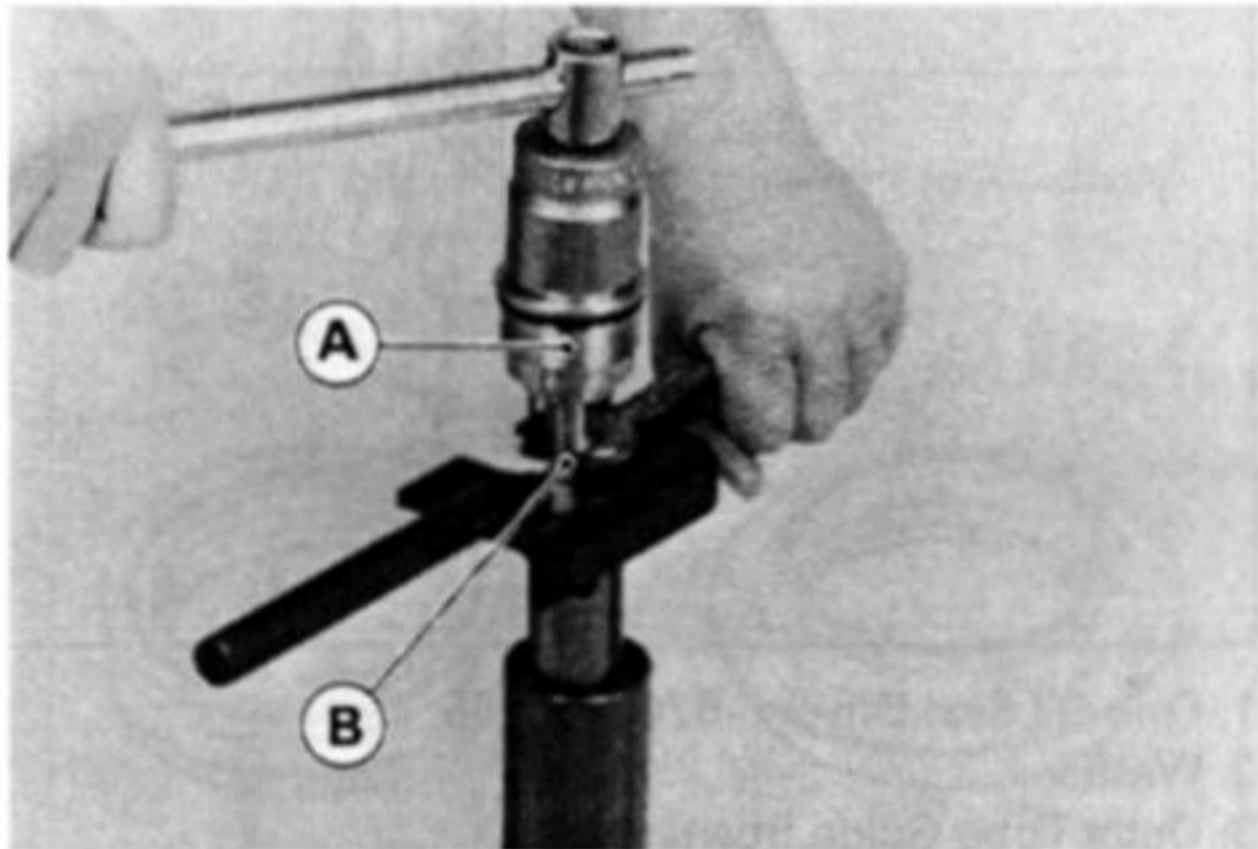

A. Top Plug B. Piston Rod Nut

- Remove the fork spring compressor (special tool).
- Raise the outer tube, and screw the top plug into it.
- Tighten the top plug to the specified torque (see Exploded View).
- Adjust the rebound damping and spring preload (see the Specifications).

Disassembly (for each leg)

- Loosen the top plug before removing the front fork.
- Remove the front fork, and then pour out the fork oil (see Fork Oil Change).
- The following parts are removed during draining the fork oil.
 - Top Plug
 - Spring Seat
 - Spring Guide
 - Collar
 - Main Spring
- Hold the fork tube horizontally in a vise.
- Unscrew the Allen bolt, and take a gasket out of the bottom of the inner tube.

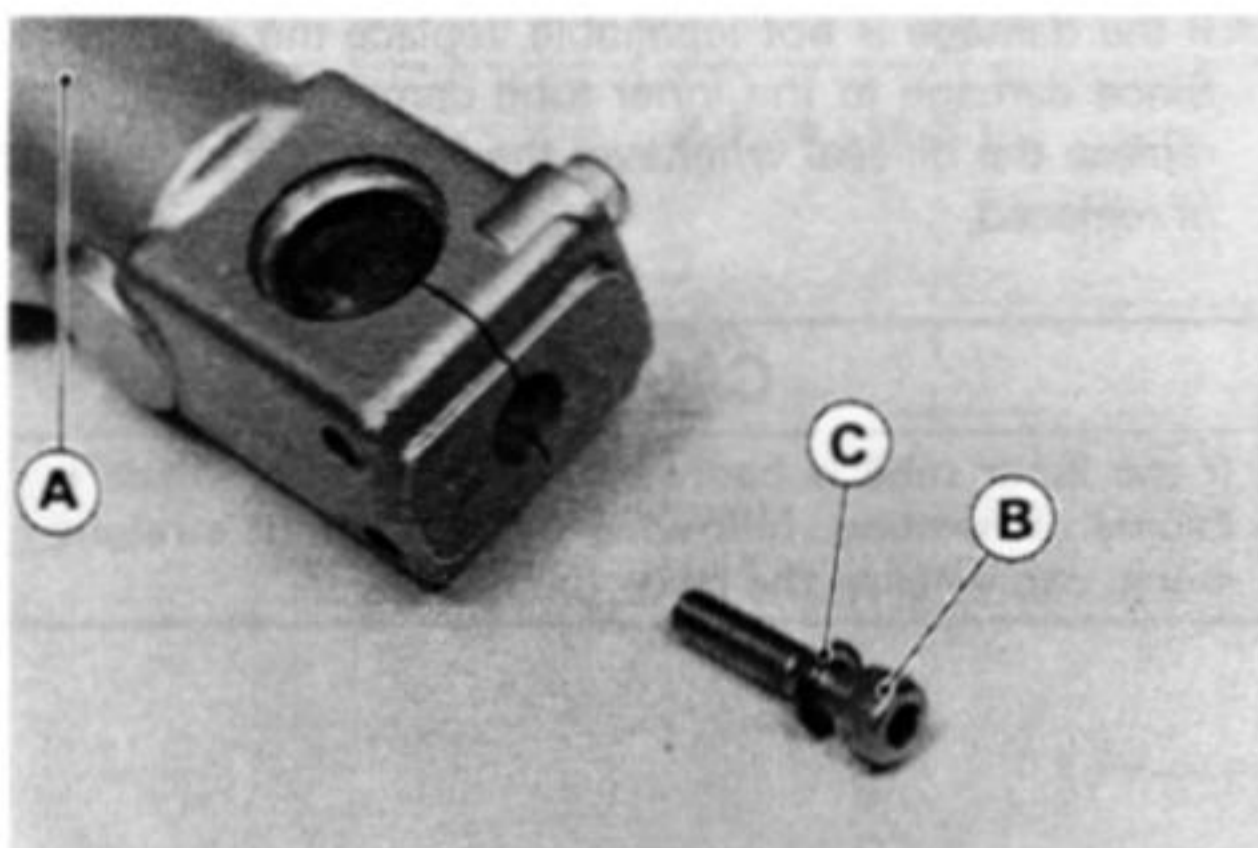

A. Inner Tube C. Gasket
B. Allen Bolt

- Take the piston cylinder unit from the top of the outer tube.
- Do not disassembly the piston cylinder unit.

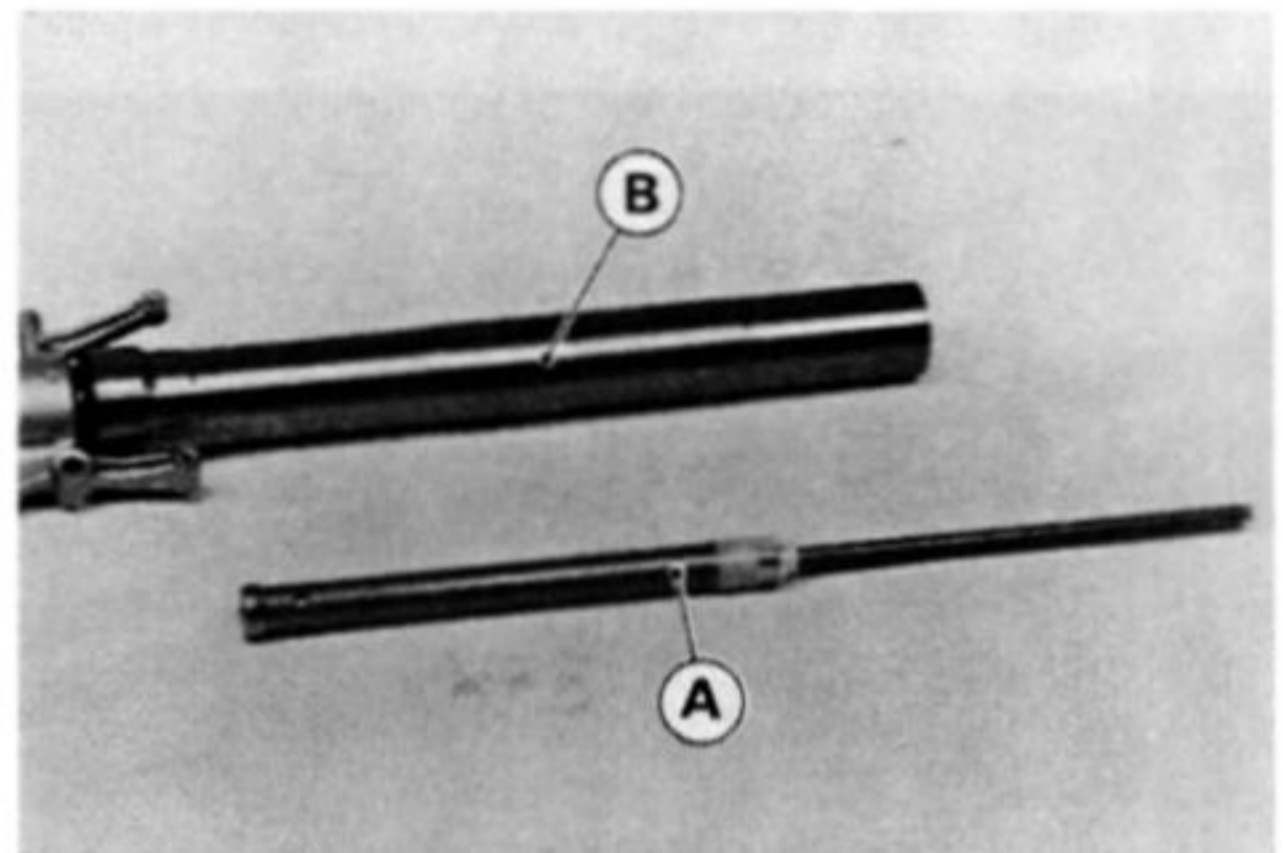

A. Piston Cylinder Unit B. Outer Tube

- Remove the following the outer tube.
 - Dust Seal
 - Retaining Ring

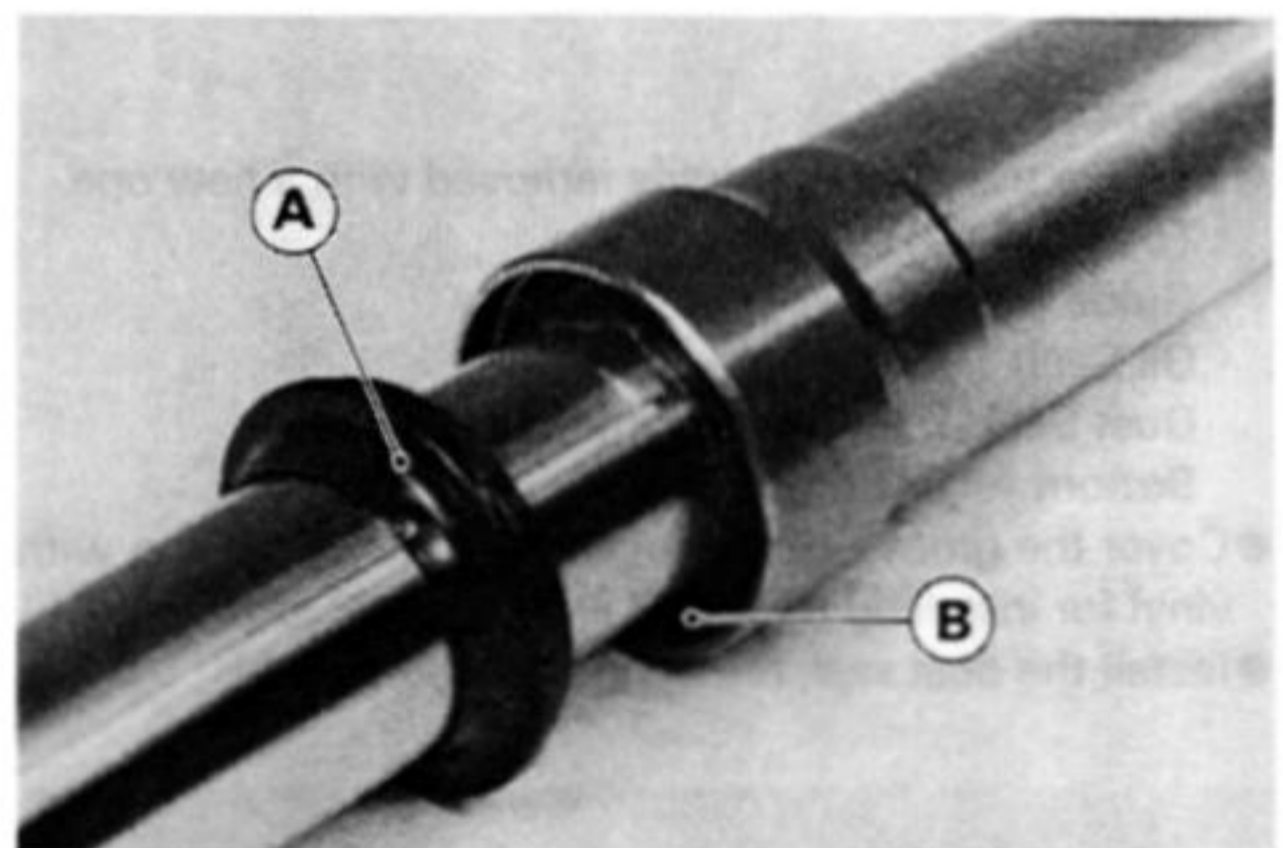

A. Dust Seal B. Retaining Ring

- Use the fork outer tube weight (special tool) to separate the outer tube from the inner tube.
- Holding the outer tube by hand, pull the outer tube several times to pull out the inner tube.

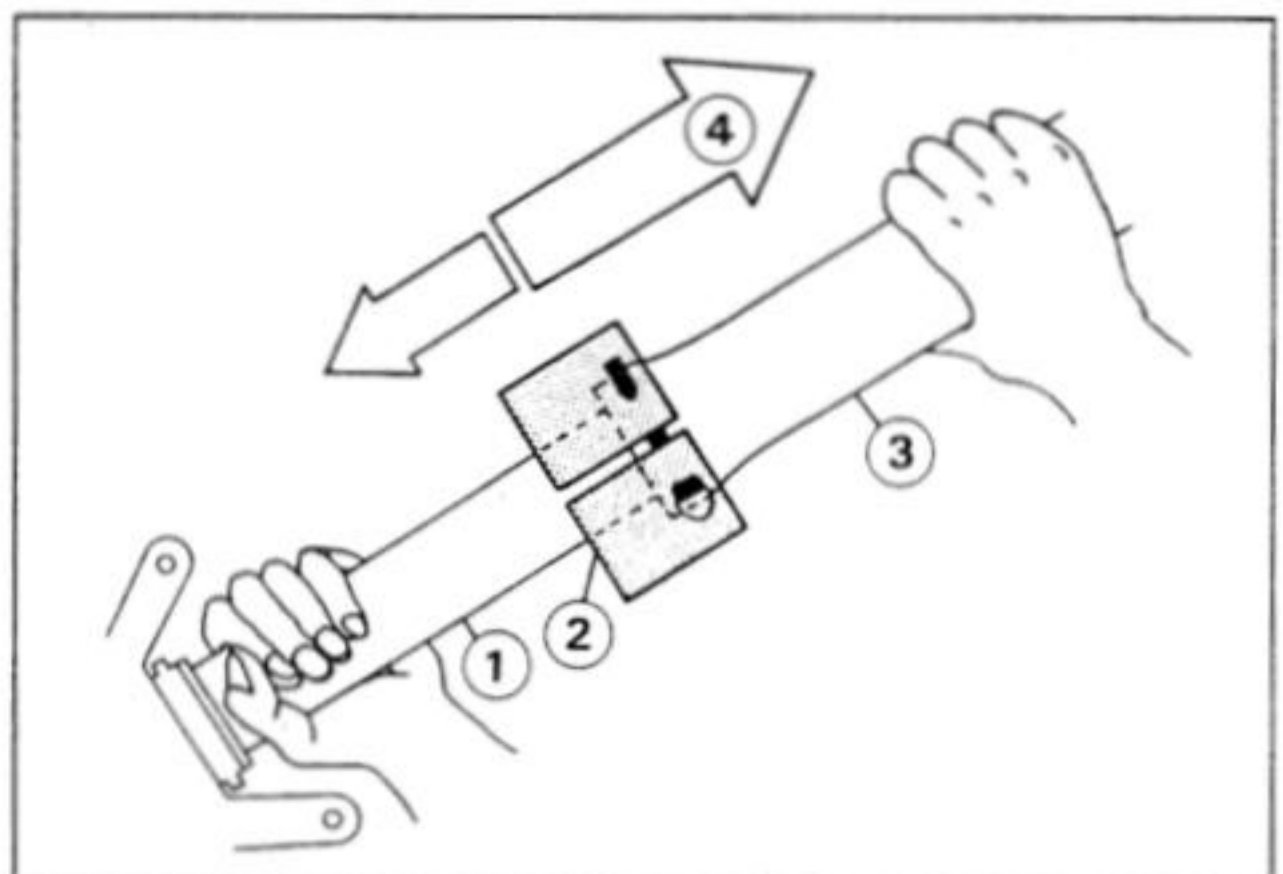

1. Inner Tube 3. Outer Tube
2. Weight : 57001-1218 4. Pull.

12-10 SUSPENSION

- The oil seal, washer, and guide bushings come off with the inner tube.
- Remove the guide bushings, washer, oil seal, retaining ring, dust seal from the inner tube.

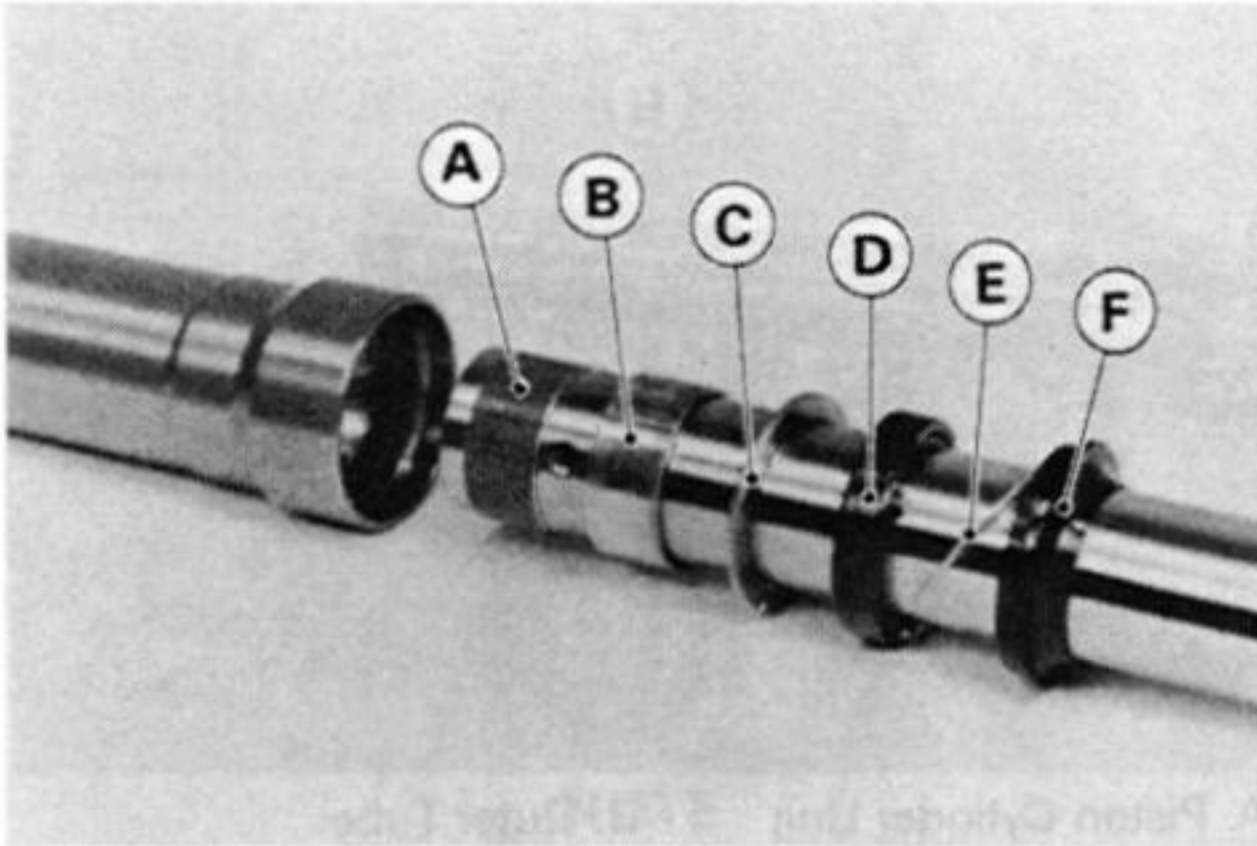

- | | |
|-----------------------------|-------------------|
| A. Inner Tube Guide Bushing | D. Oil Seal |
| B. Outer Tube Guide Bushing | E. Retaining Ring |
| C. Washer | F. Dust Seal |

Assembly

- Replace the following parts removed with a new one.
 - Top Plug O-Ring
 - Guide Bushings
 - Oil Seal
 - Dust Seal (If removed from the inner tube)
 - Bottom Allen Bolt Gasket
- Cover the groove of the inner tube guide bushing with vinyl for installing a new oil seal and dust seal.
- Install the dust seal, retaining ring and oil seal.

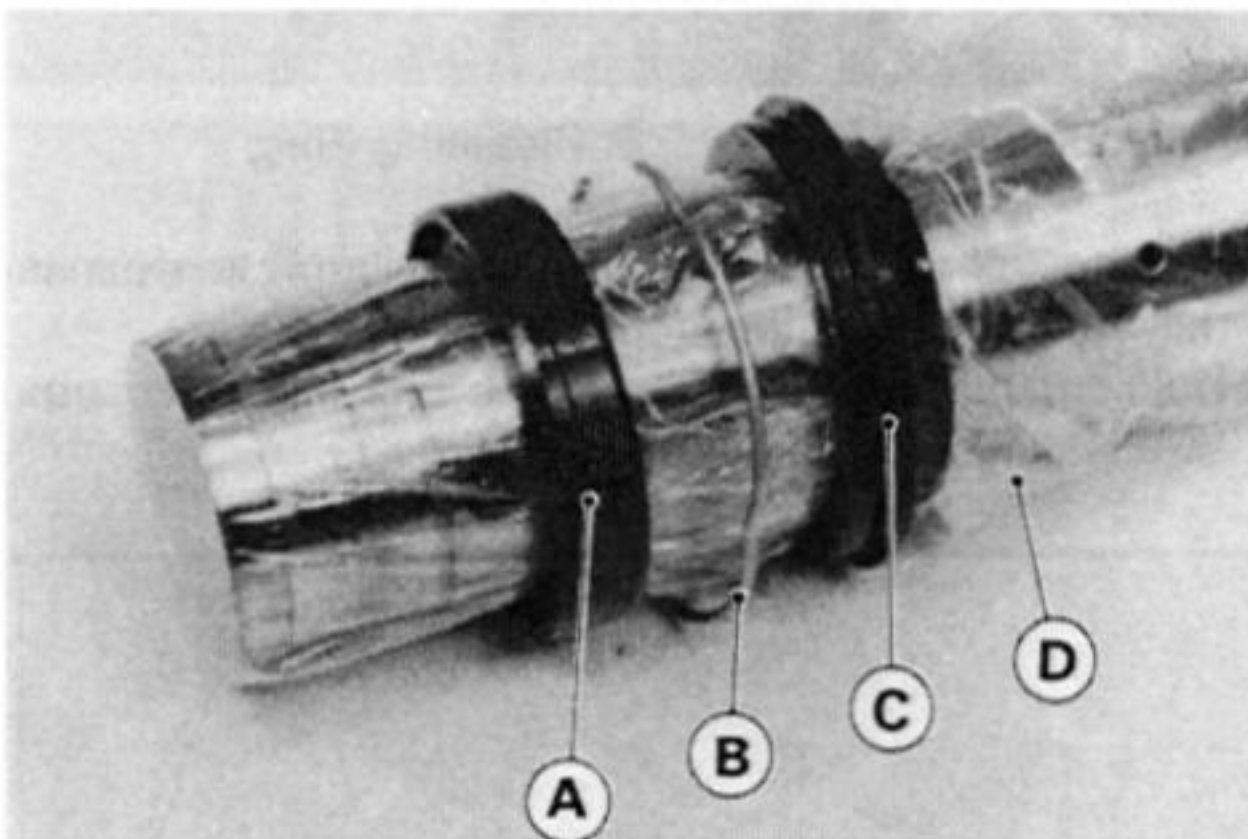

- | | |
|-------------------|--------------|
| A. Oil Seal | C. Dust Seal |
| B. Retaining Ring | D. Vinyl |

- Remove the vinyl.
- Install the following onto the inner tube.
 - Washer
 - Outer Tube Guide Bushing
 - Inner Tube Guide Bushing
- When installing the inner tube into the outer tube, put the washer on the outer tube guide bushing, and tap the washer with the fork oil seal driver (special tool) until it stops.

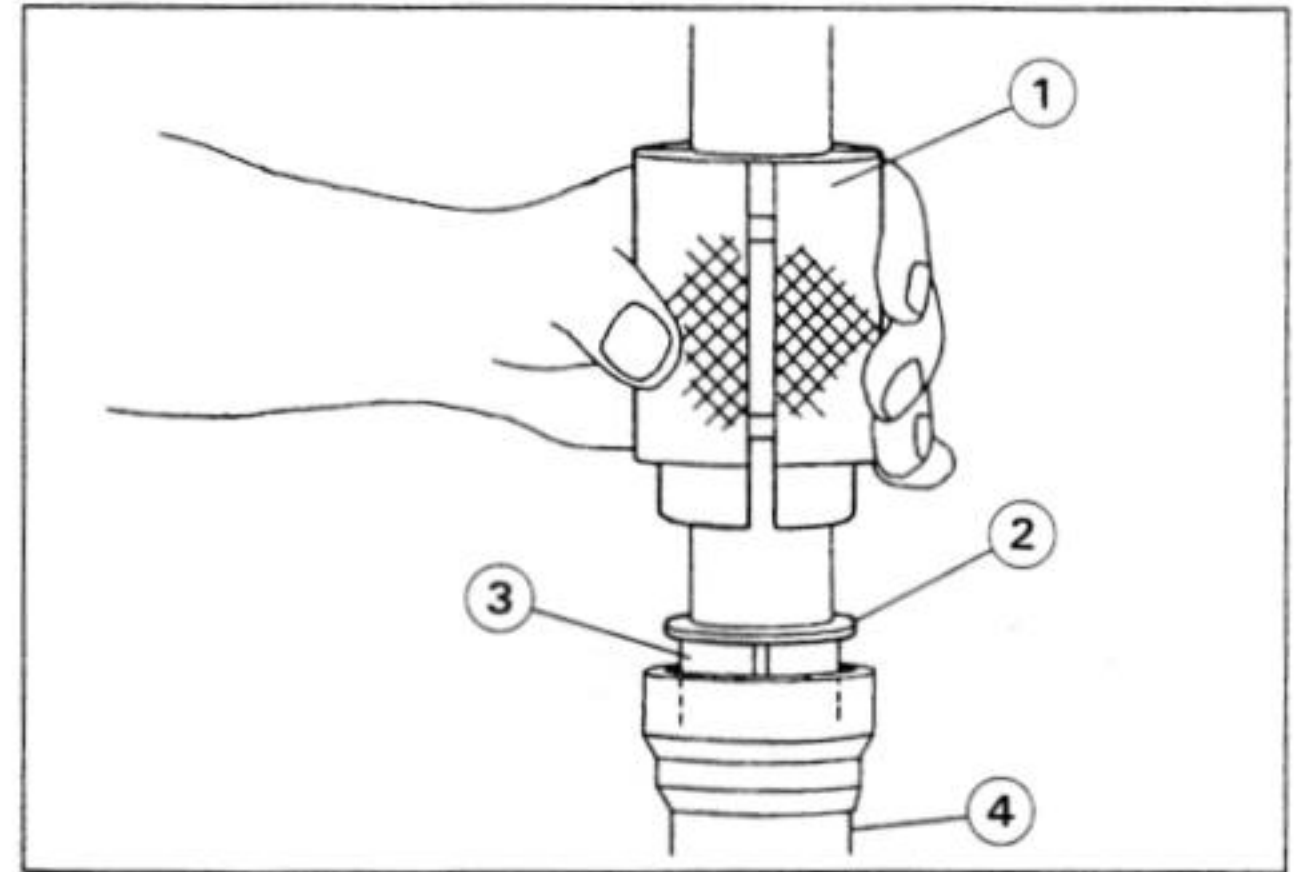

1. Fork Oil Seal Driver : 57001-1288
2. Washer
3. Outer Tube Guide Bushing
4. Outer Tube

- Install the oil seal into the outer tube, using the oil seal driver (special tool).
- Install the following by hand.
 - Retainer
 - Dust Seal
- Hold the fork tube horizontally in a vise.
- Install the piston cylinder unit in the inner tube.
- Apply a non-permanent locking agent to the Allen bolt and tighten it to the specified torque (see Exploded View).
- Hold the fork tube vertically in a vise.
- Press the outer tube and the piston rod all the way down.
- Install the main spring into the inner tube.
- Pour in the specified type of oil and install the parts removed (see Fork Oil Change).

Inner Tube Inspection

- ★ If the inner tube is damaged, replace it.
 - Nicks or rust damage can sometimes be repaired by using a wet-stone to remove sharp edges or raised areas which cause seal damage.
- ★ If the damage is not repairable, replace the inner tube. Since damage to the inner tube damages the oil seal, replace the oil seal whenever the inner tube is repaired or replaced.

CAUTION

If the inner tube is badly bent or creased, replace it. Excessive bending, followed by subsequent straightening, can weaken the inner tube.

Oil Seal and Dust Seal Inspection

- ★ If dust seal has any damage or wear, replace it.
- Replace the oil seal with a new one whenever it has been removed.

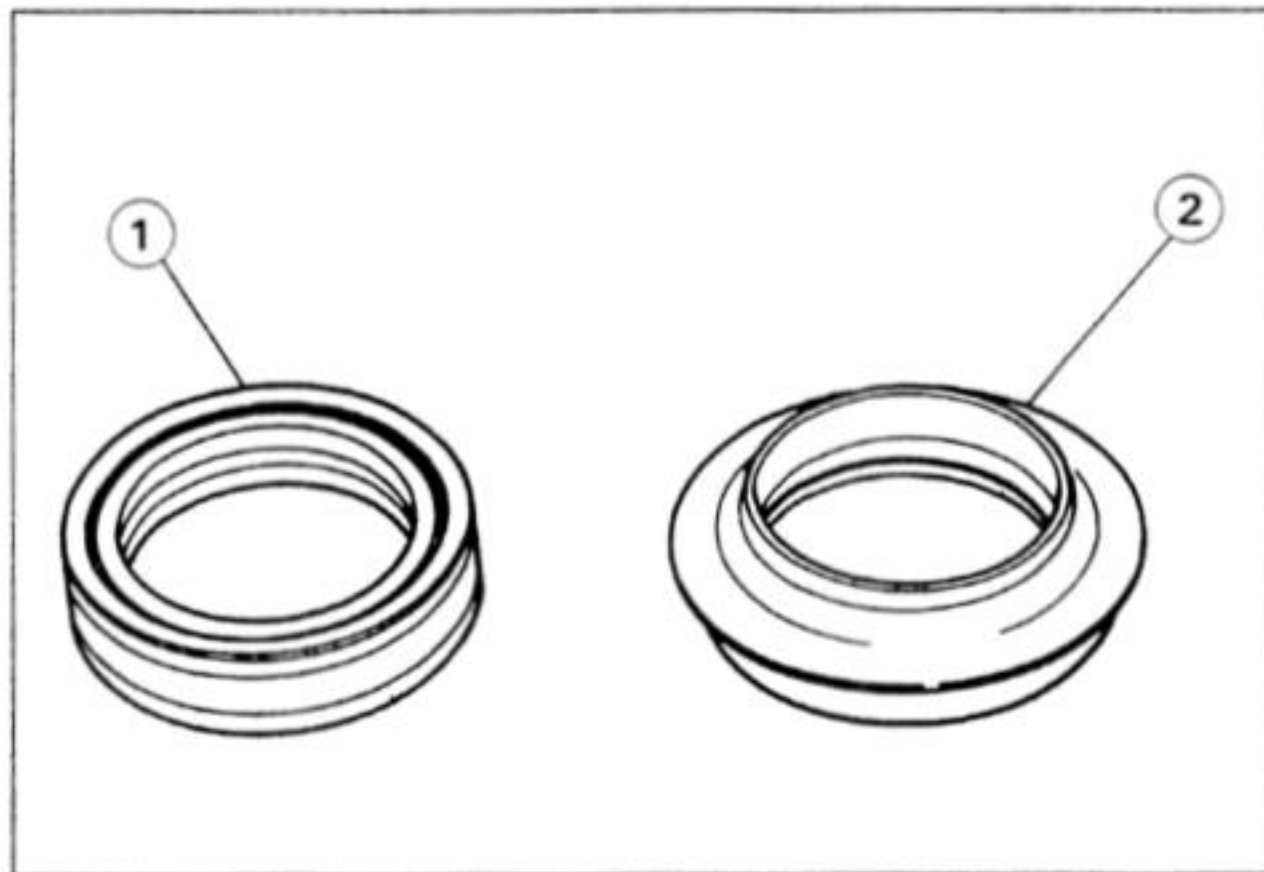

1. Oil Seal

2. Dust Seal

Spring Tension

- ★ If the spring of either fork tube is shorter than the service limit, it must be replaced. If the length of a replacement spring and that of the remaining spring vary greatly, the remaining spring should also be replaced in order to keep the fork tubes balanced for motorcycle stability.

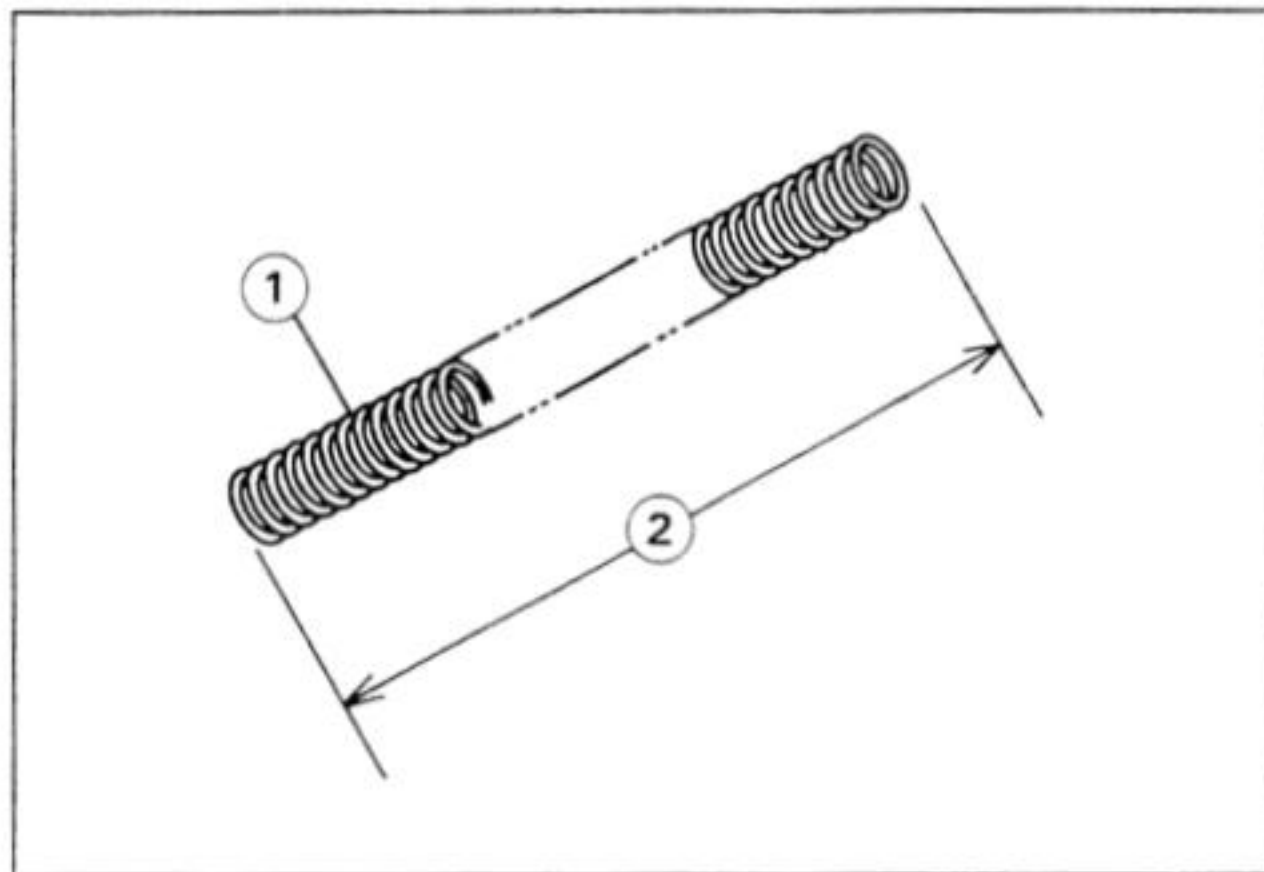

1. Main Spring

2. Free Length

Fork Spring Length

Standard: 325.1 mm
Service Limit: 319 mm

Steering

Table of Contents

Exploded View13-2
Special Tools13-3

13-2 STEERING

Exploded View

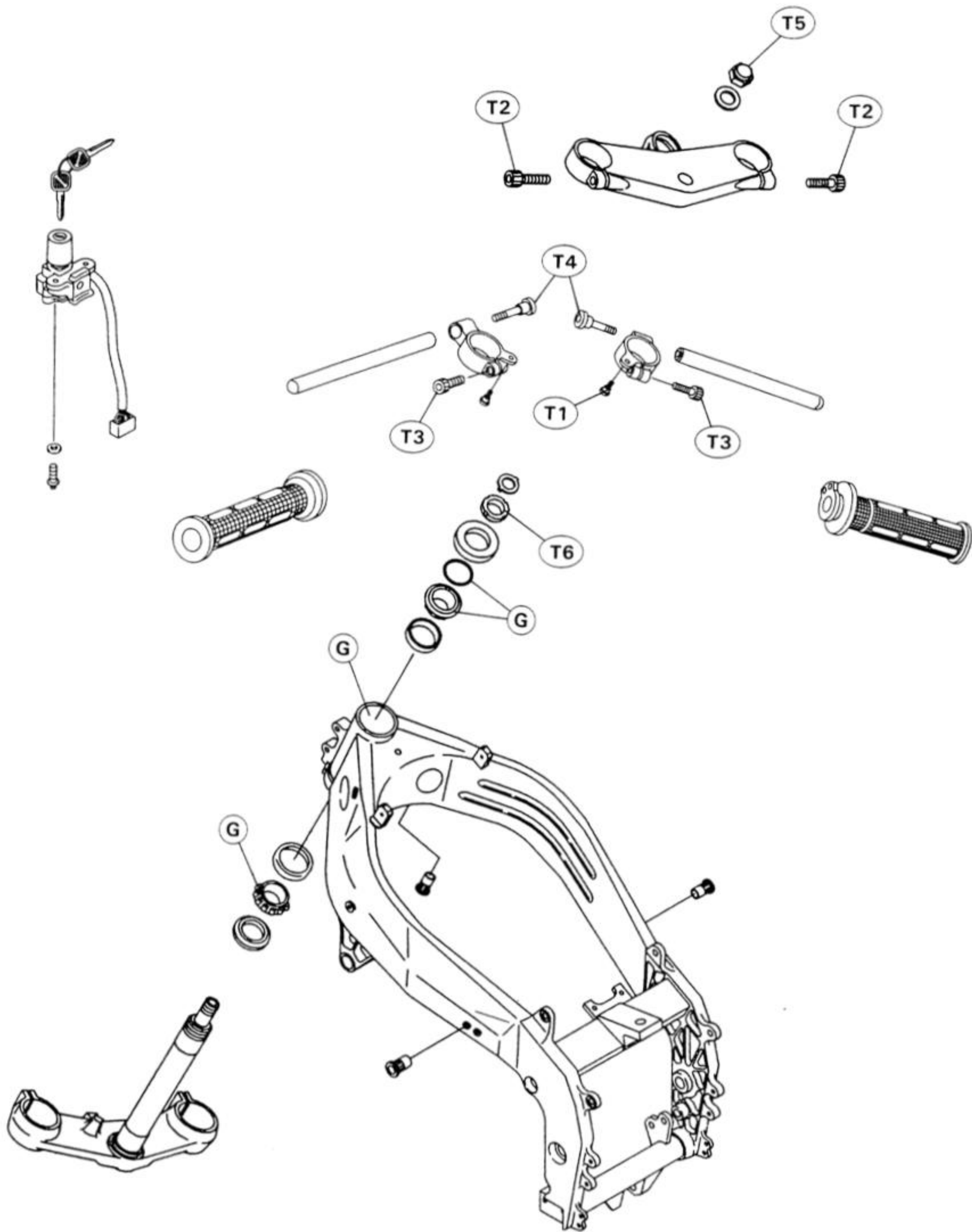

- T1: 9.8 N-m (1.0 kg-m, 7.0 ft-lb)
- T2: 20 N-m (2.0 kg-m, 14.5 ft-lb)
- T3: 23 N-m (2.3 kg-m, 16.5 ft-lb)
- T4: 34 N-m (3.5 kg-m, 25 ft-lb)
- T5: 54 N-m (5.5 kg-m, 40 ft-lb)
- T6: Tighten all snugly, then loosen. Retighten to 4.9 N-m (0.5 kg-m, 43 in-lb).

G : Apply grease.

Special Tools

Steering Stem Bearing Driver: 57001-1344

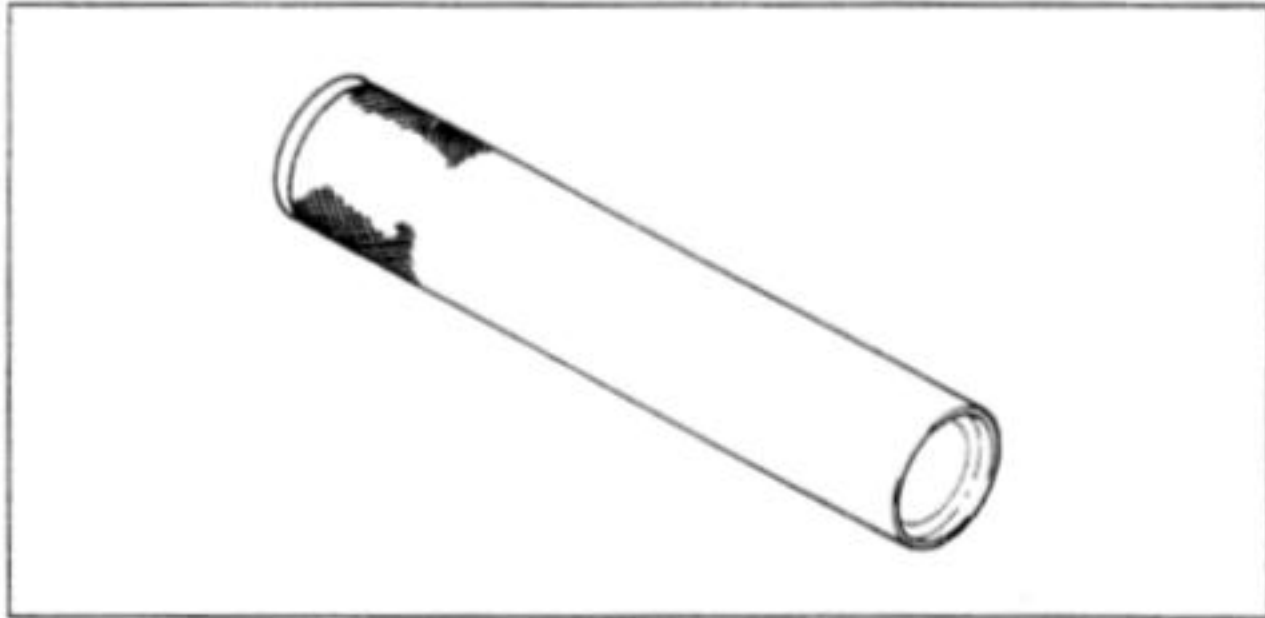

Head Pipe Outer Race Driver: 57001-1106

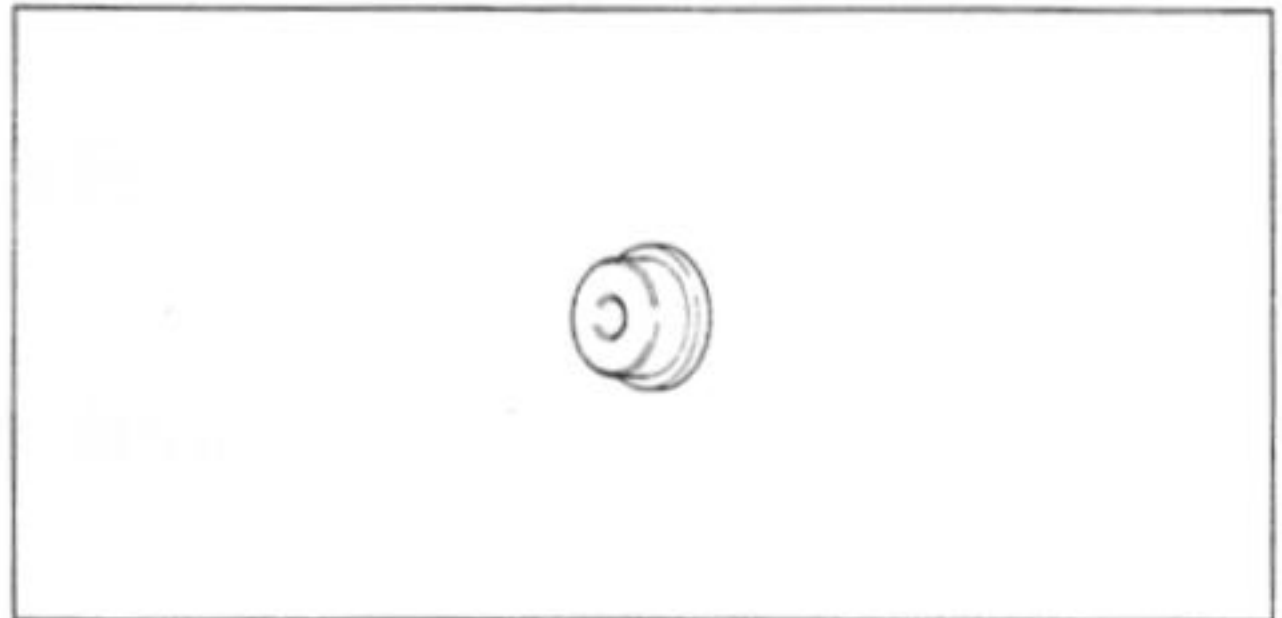

Steering Stem Bearing Driver Adapter: 57001-1345

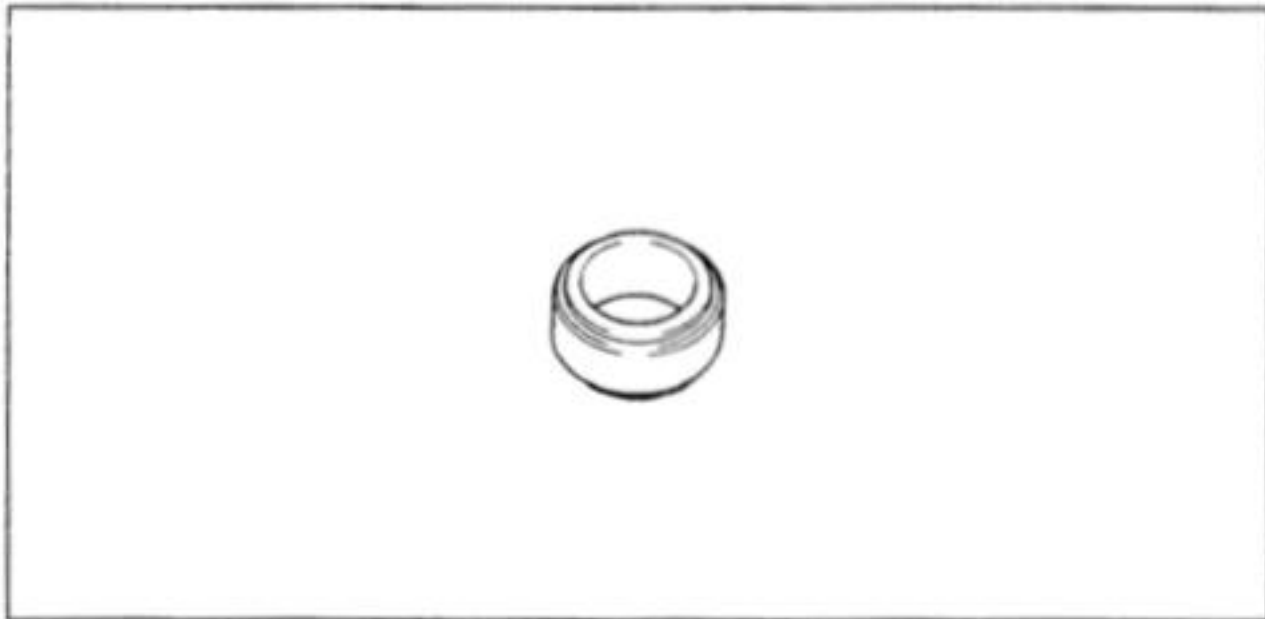

Steering Stem Nut Wrench: 57001-1100

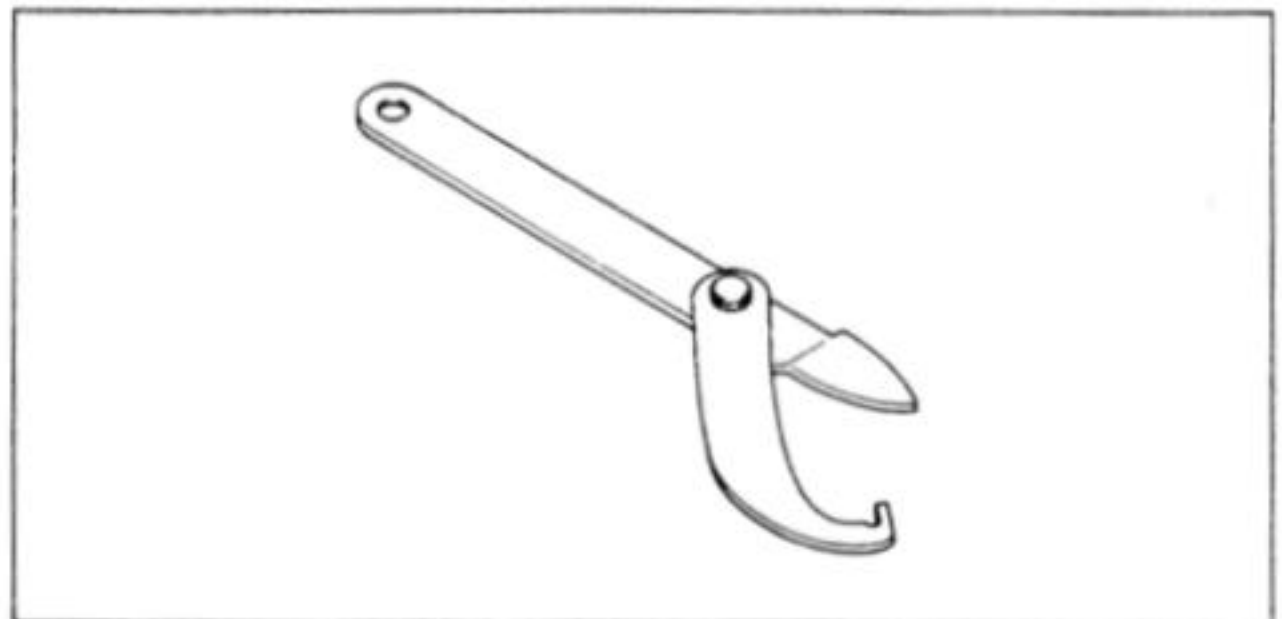

Bearing Puller: 57001-158

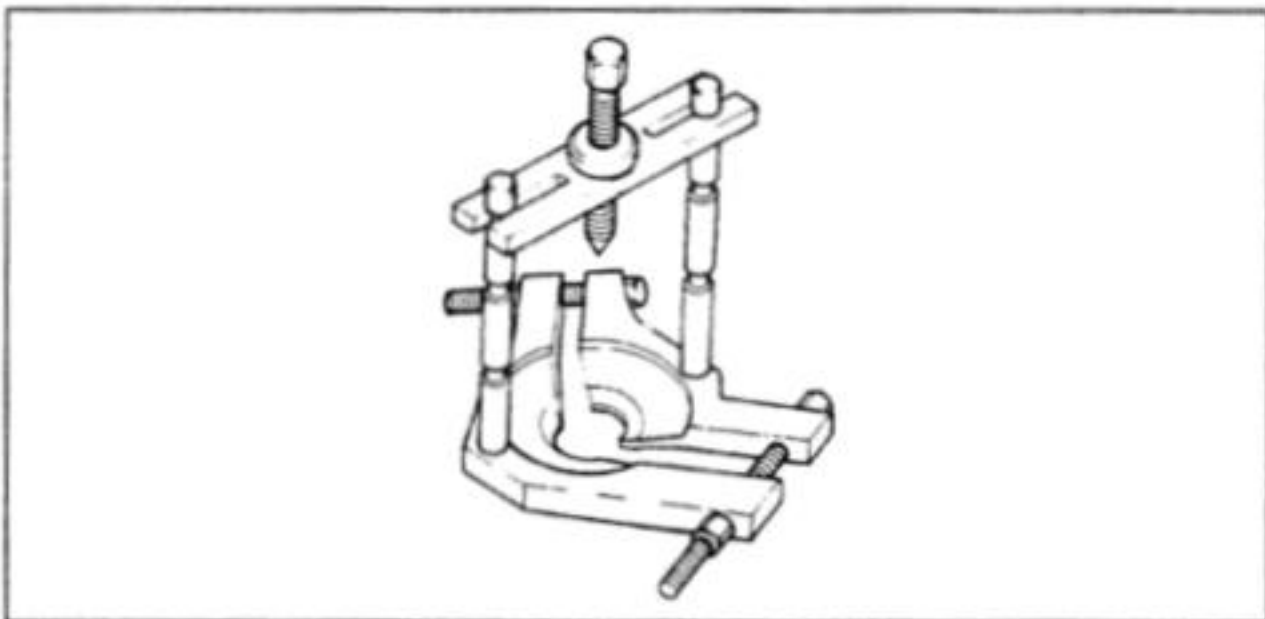

Head Pipe Outer Race Remover: 57001-1107

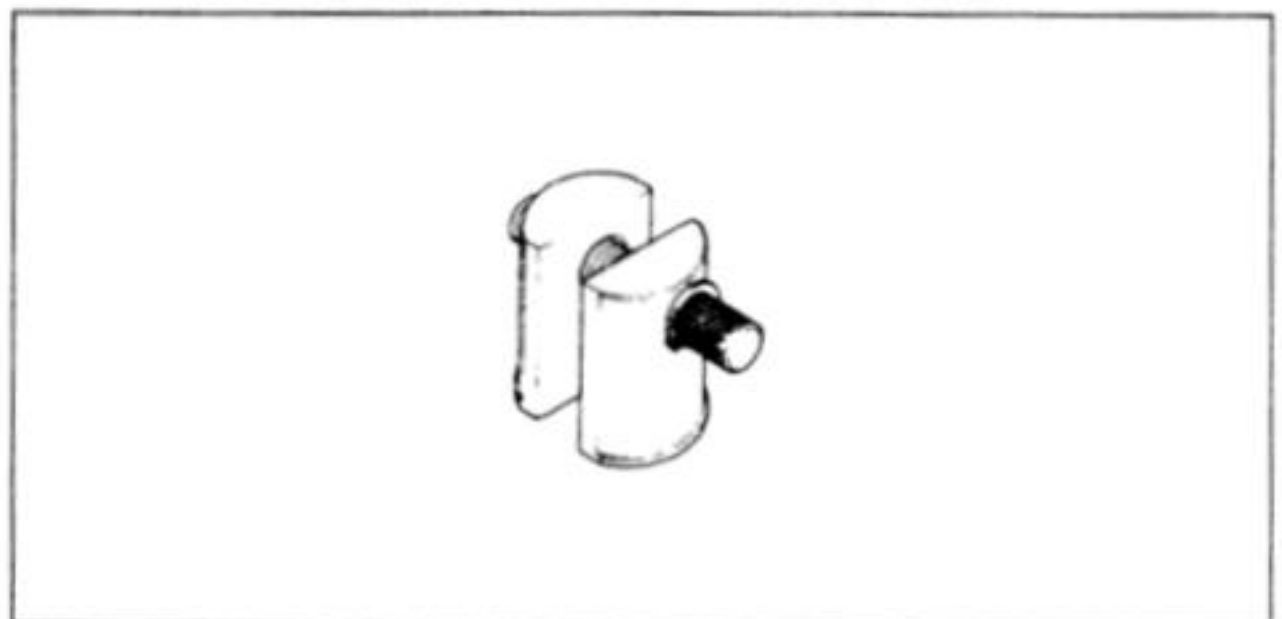

Bearing Puller Adapter: 57001-317



Jack: 57001-1238

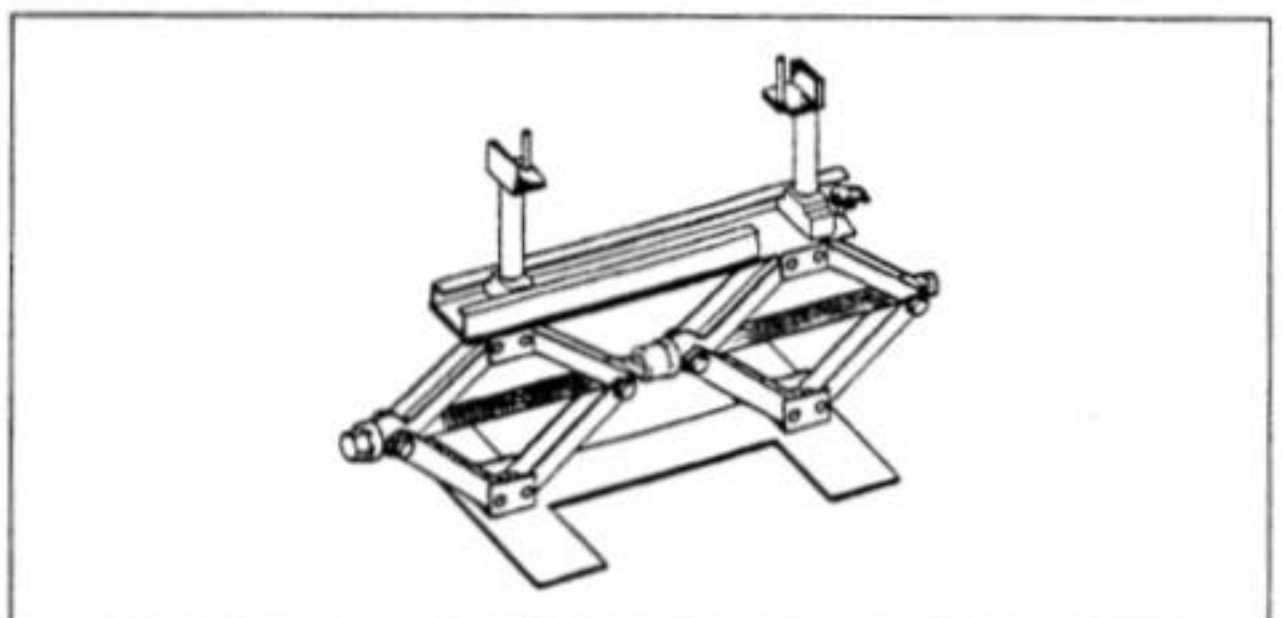

Head Pipe Outer Race Press Shaft: 57001-1075

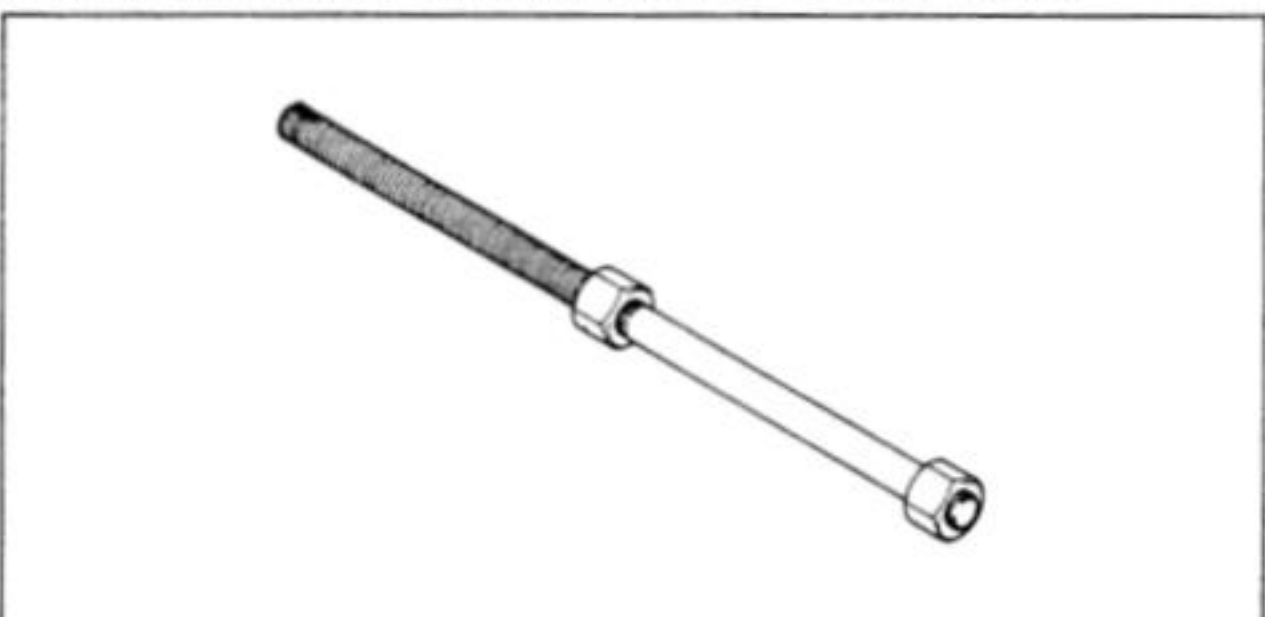

Bearing Puller Stud: 57001-1190

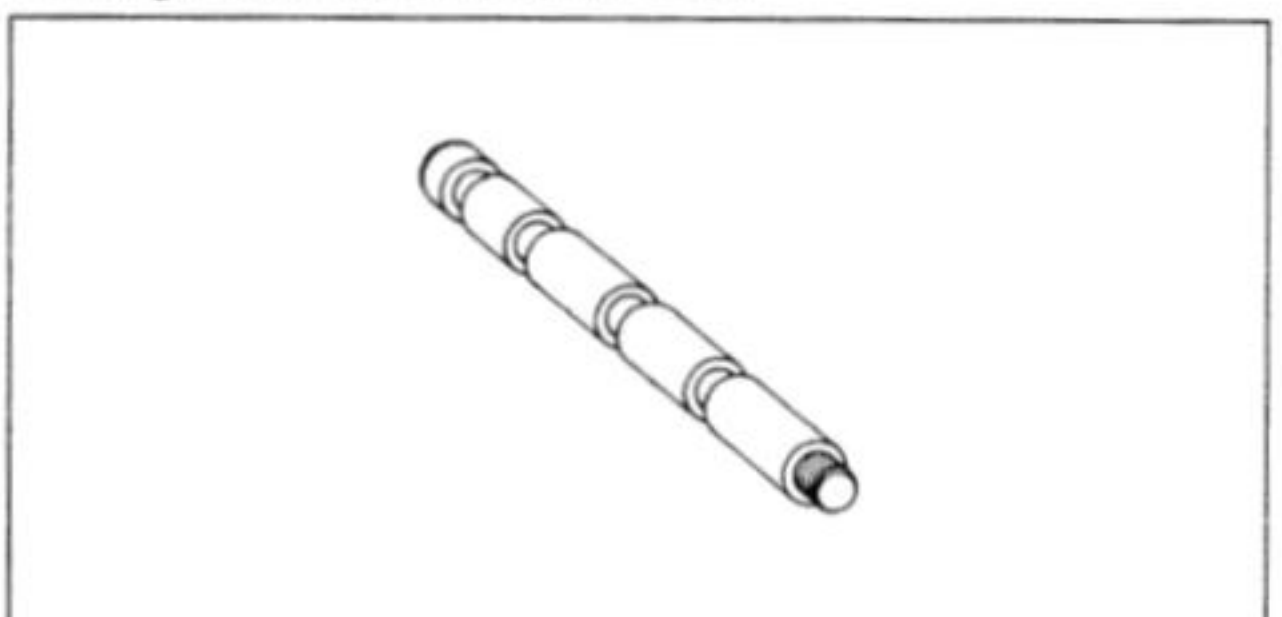

Frame

Table of Contents

Exploded View14-2

14-2 FRAME

Exploded View

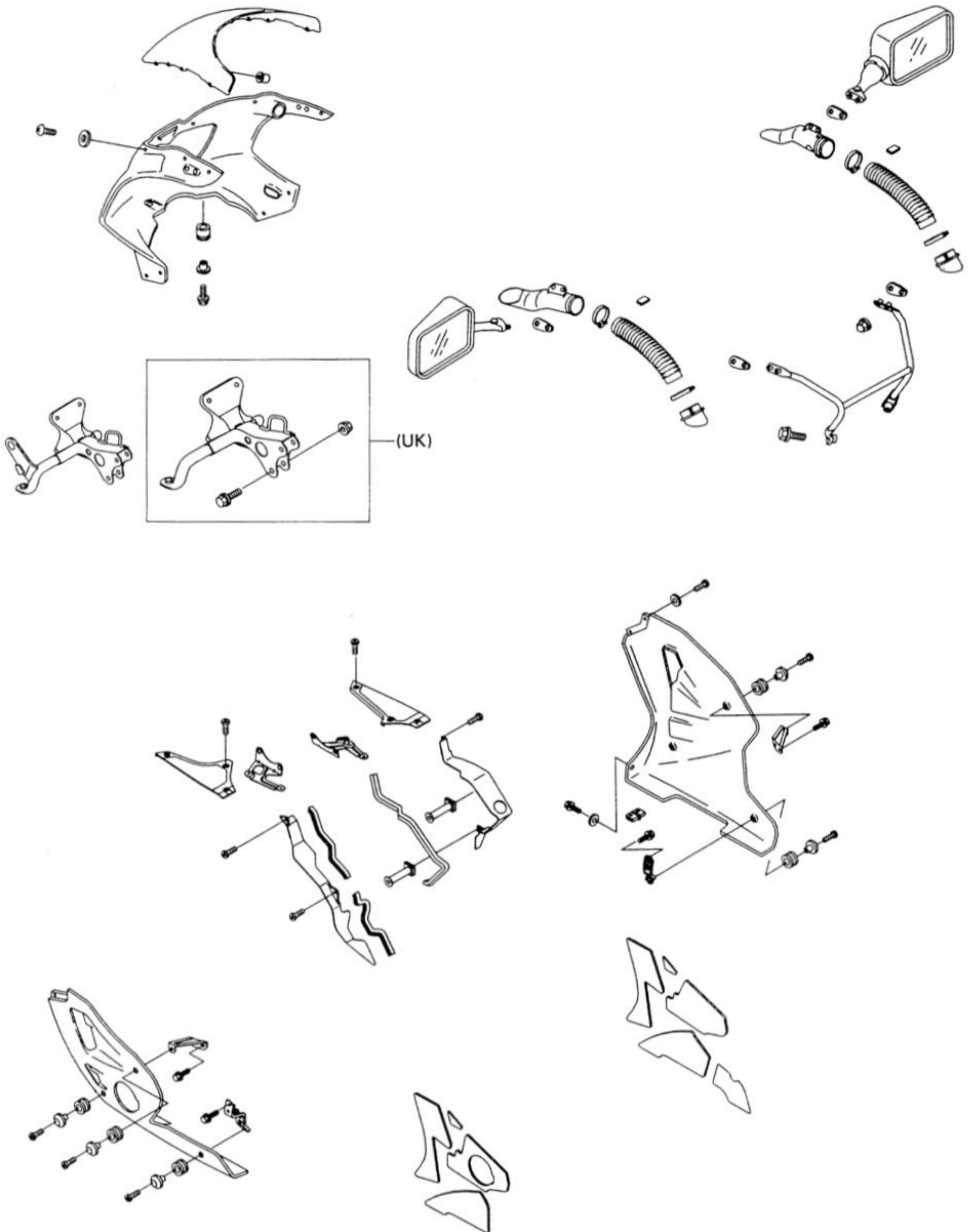

UK : U.K. Model

FRAME 14-3

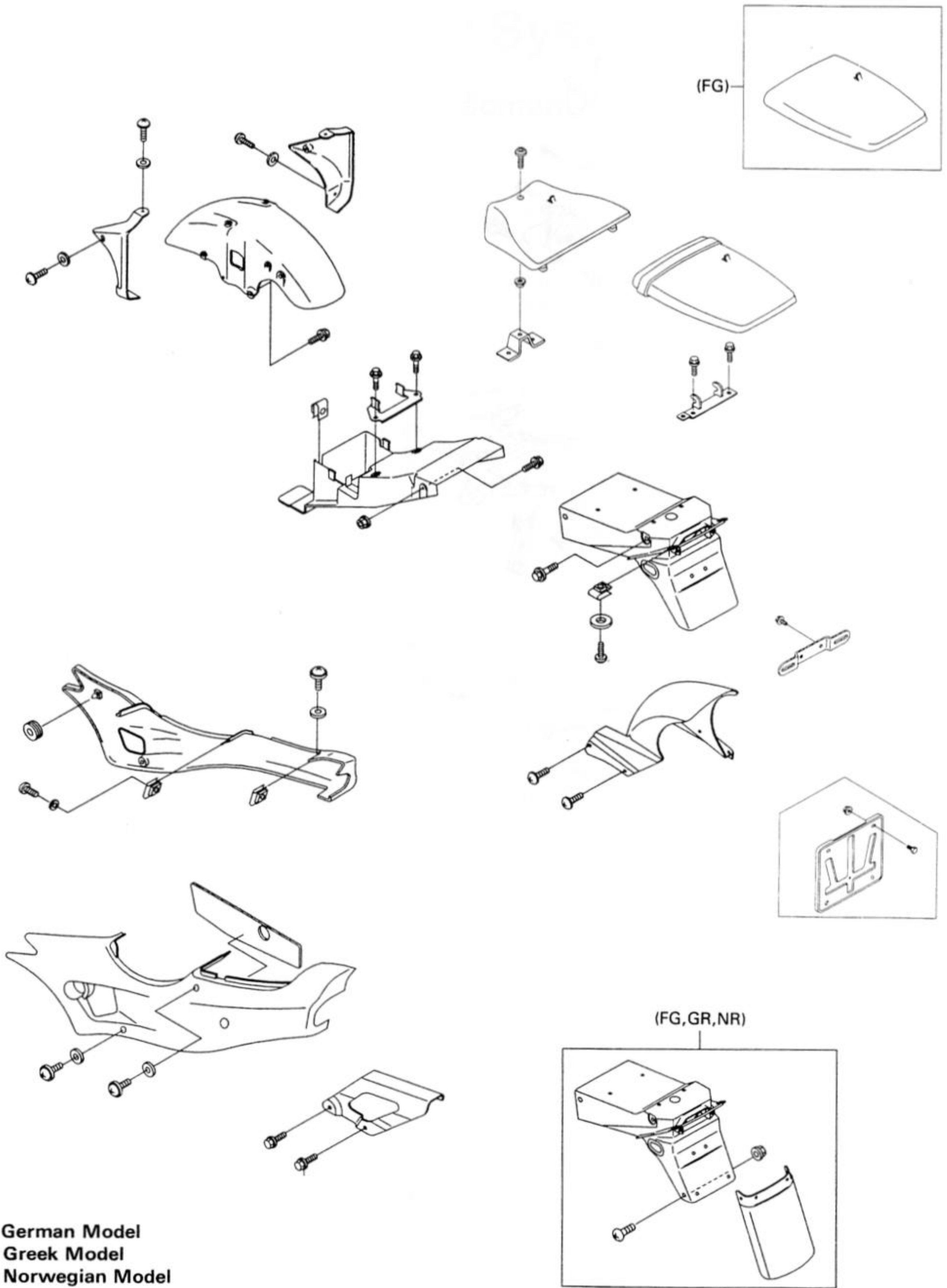

FG : German Model
GR : Greek Model
NR : Norwegian Model

14-4 FRAME

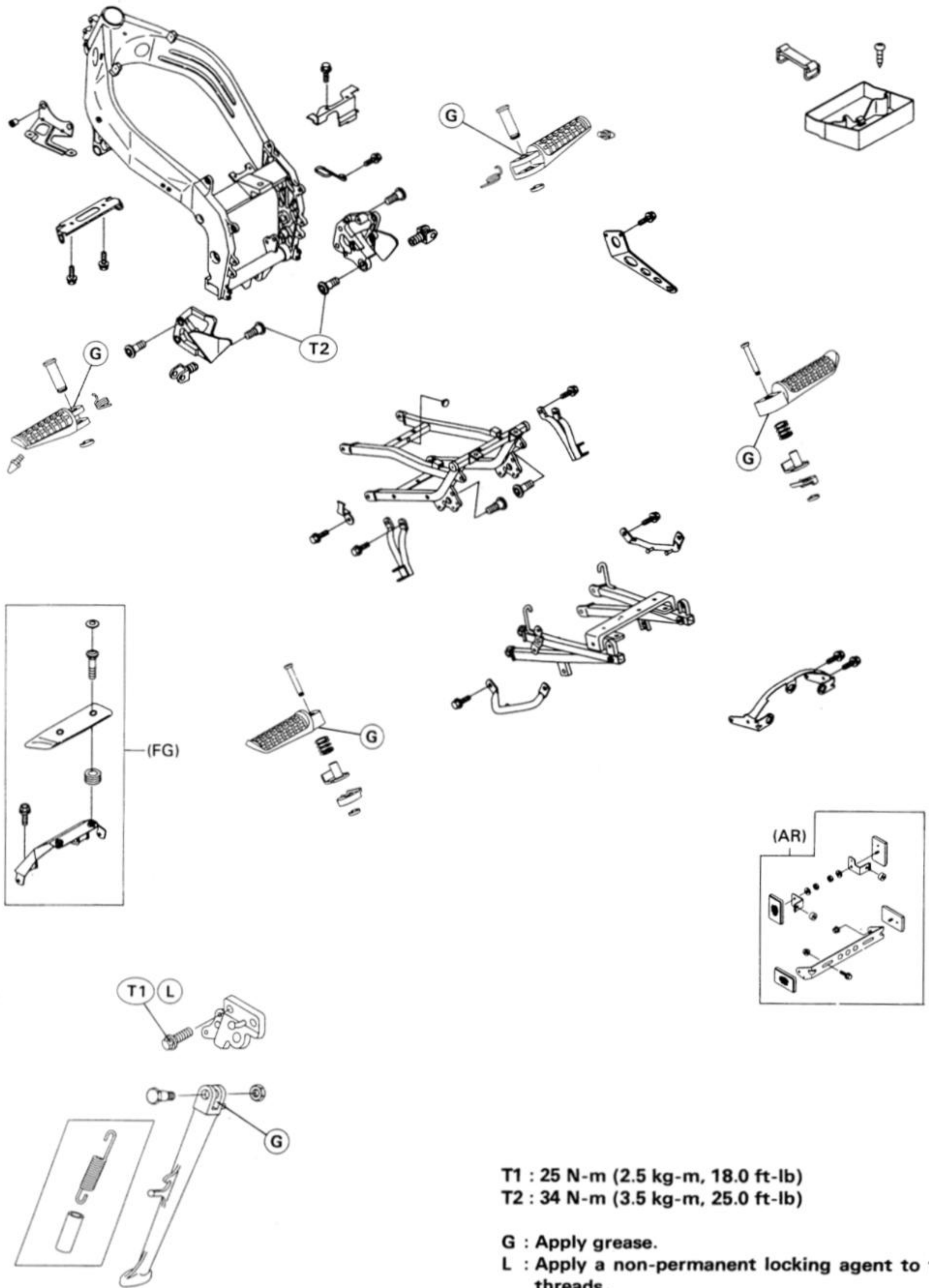

T1 : 25 N-m (2.5 kg-m, 18.0 ft-lb)
T2 : 34 N-m (3.5 kg-m, 25.0 ft-lb)

G : Apply grease.
L : Apply a non-permanent locking agent to the threads.

FG : German Model
AR : Austrian Model

Electrical System

Table of Contents

Precaution	15-2	Brush Inspection	15-22
Exploded View	15-3	Commutator Cleaning and Inspection.....	15-22
Specifications	15-6	Armature Inspection	15-22
Special Tools	15-7	Brush Lead Inspection	15-23
Sealant.....	15-7	Brush Plate and Terminal Bolt Inspection	15-23
Parts Location	15-8	Starter Relay Inspection	15-23
Wiring Diagram (ZX400-L1 ~ L4)	15-9	Lighting System	15-25
Wiring Diagram (ZX400-L5)	15-10	Headlight Beam Horizontal Adjustment.....	15-25
Battery	15-11	Headlight Beam Vertical Adjustment.....	15-25
Charging Condition Inspection	15-11	Headlight Bulb Replacement Notes	15-25
Refreshing Charge.....	15-11	Headlight Unit Removal/Installation Note	15-26
Charging System.....	15-12	Tail/Brake Light Bulb Replacement Notes.....	15-26
Alternator Cover Removal	15-12	Turn Signal Light Bulb Replacement Note	15-26
Alternator Cover Installation	15-12	Turn Signal Relay Inspection.....	15-26
Alternator Rotor Removal	15-13	Cooling Fan System.....	15-29
Alternator Rotor Installation Notes	15-13	Fan System Circuit Inspection	15-29
Stator Coil Removal	15-14	Fan Inspection.....	15-29
Stator Installation Notes.....	15-14	Fan Installation	15-29
Alternator Inspection.....	15-14	Fuel Pump	15-30
Rectifier Inspection.....	15-15	Fuel Pump Relay Inspection	15-30
Regulator Inspection	15-16	Pump Operation Inspection	15-30
Regulator/Rectifier Output		Meters, Gauges	15-31
Voltage Inspection	15-17	Removal.....	15-31
Ignition System	15-17	Bulb Replacement.....	15-31
Pickup Coil Removal.....	15-17	Meter, Gauge Assembly Note.....	15-32
Pickup Coil Installation	15-17	Tachometer Inspection.....	15-32
Pickup Coil Inspection	15-17	Water Temperature Gauge	
Ignition Coil Removal	15-18	Operation Inspection	15-32
Ignition Coil Installation.....	15-18	Water Temperature Sensor Inspection	15-34
Ignition Coil Inspection.....	15-18	Fan Switch Inspection	15-34
Spark Plug Removal.....	15-19	Junction Box.....	15-35
Spark Plug Installation Note.....	15-20	Fuse Removal	15-35
Spark Plug Cleaning and Inspection	15-20	Fuse Installation	15-35
Spark Plug Gap Inspection	15-20	Fuse Inspection	15-35
IC Igniter Inspection.....	15-20	Junction Box Fuse Circuit Inspection	15-35
Electric Starter System	15-21	Starter Circuit.....	15-36
Starter Motor Removal.....	15-21	Diode Circuit Inspection	15-36
Starter Motor Installation	15-21	Electrical Wiring	15-38
Starter Motor Disassembly.....	15-21	Wiring Inspection	15-38
Starter Motor Assembly Note	15-22		

15-2 ELECTRICAL SYSTEM

Precautions

There are numbers of important precautions that are musts when servicing electrical systems. Learn and observe all the rules below.

- Do not reverse the battery lead connections. This will burn out the diodes in the electrical parts.
- Always check battery condition before condemning other parts of an electrical system. A fully charged battery is a must for conducting accurate electrical system tests.
- The electrical parts should never be struck sharply, as with a hammer, or allowed to fall on a hard surface. Such a shock to the parts can damage them.
- To prevent damage to electrical parts, do not disconnect the battery leads or any other electrical connections when the ignition switch is on, or the engine is running.
- Do not use a meter illumination bulb rated for other than the voltage or wattage specified in the wiring diagram, as the meter or gauge panel could be warped by excessive heat radiated from the bulb.
- Take care not to short the leads that are directly connected to the battery positive (+) terminal to the chassis ground.
- Troubles may involve one or in some cases all items. Never replace a defective part without determining what CAUSED the failure. If the failure was caused by some other item or items, they too must be repaired or replaced, or the new replacement will soon fail again.
- Make sure all connectors in the circuit are clean and tight, and examine wires for signs of burning, fraying, etc. Poor wires and bad connections will affect electrical system operation.
- Measure coil and winding resistance when the part is cold (at room temperature).
- Color Codes:
 - BK Black
 - BL Blue
 - BR Brown
 - CH Chocolate
 - DG Dark green
 - G Green
 - GY Gray
 - LB Light blue
 - LG Light green
 - O Orange
 - P Pink
 - PU Purple
 - R Red
 - W White
 - Y Yellow

○ Electrical Connectors

Female Connectors

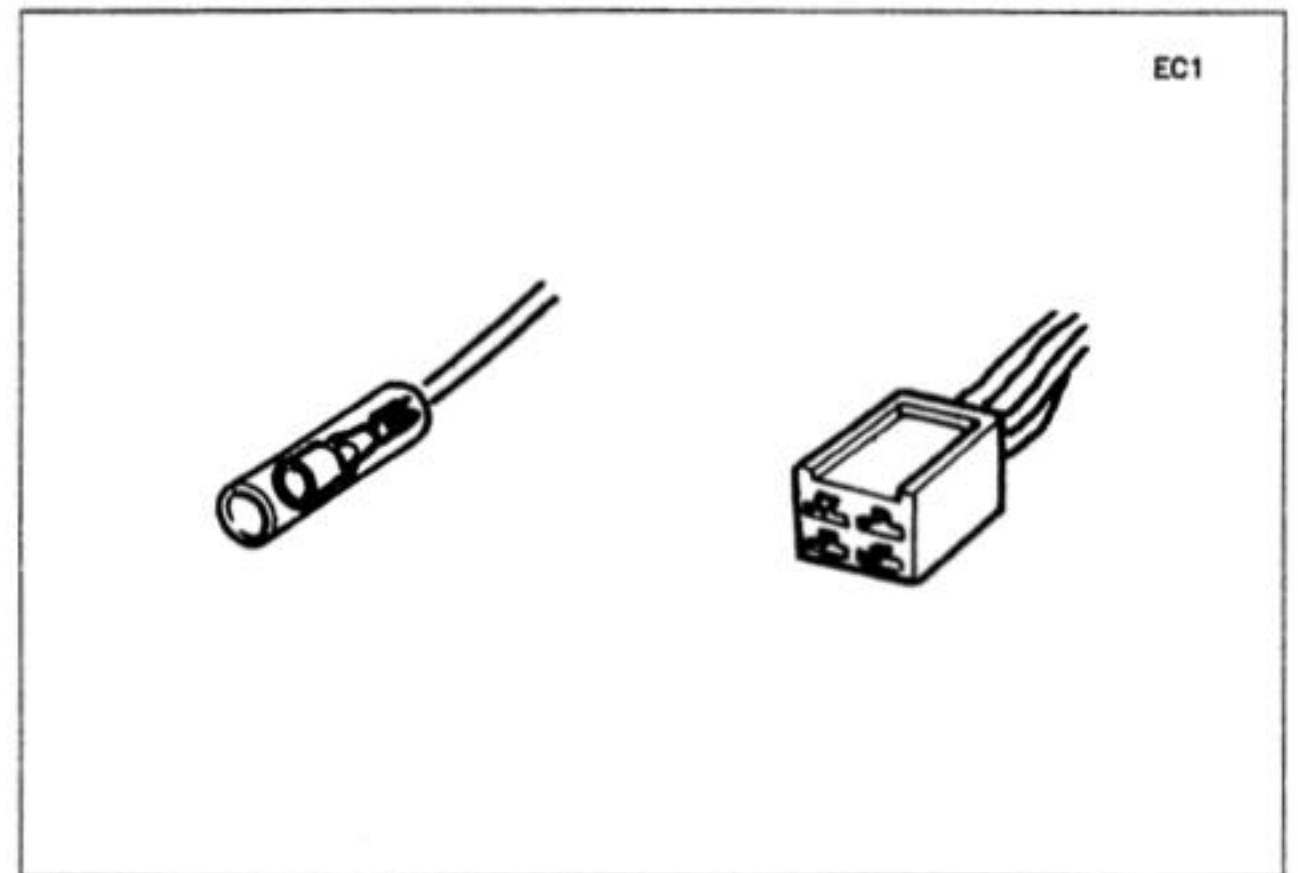

Male Connectors

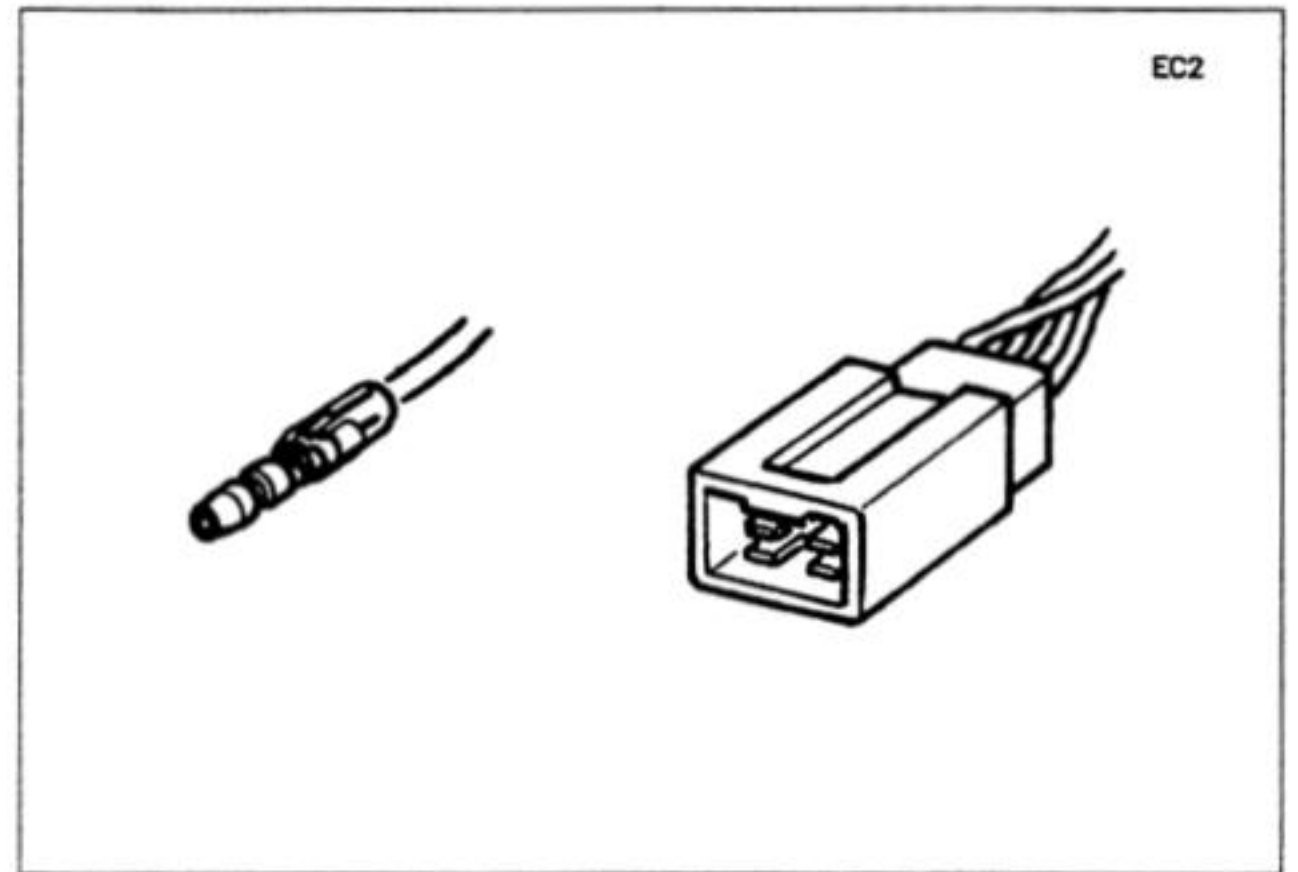

Exploded View

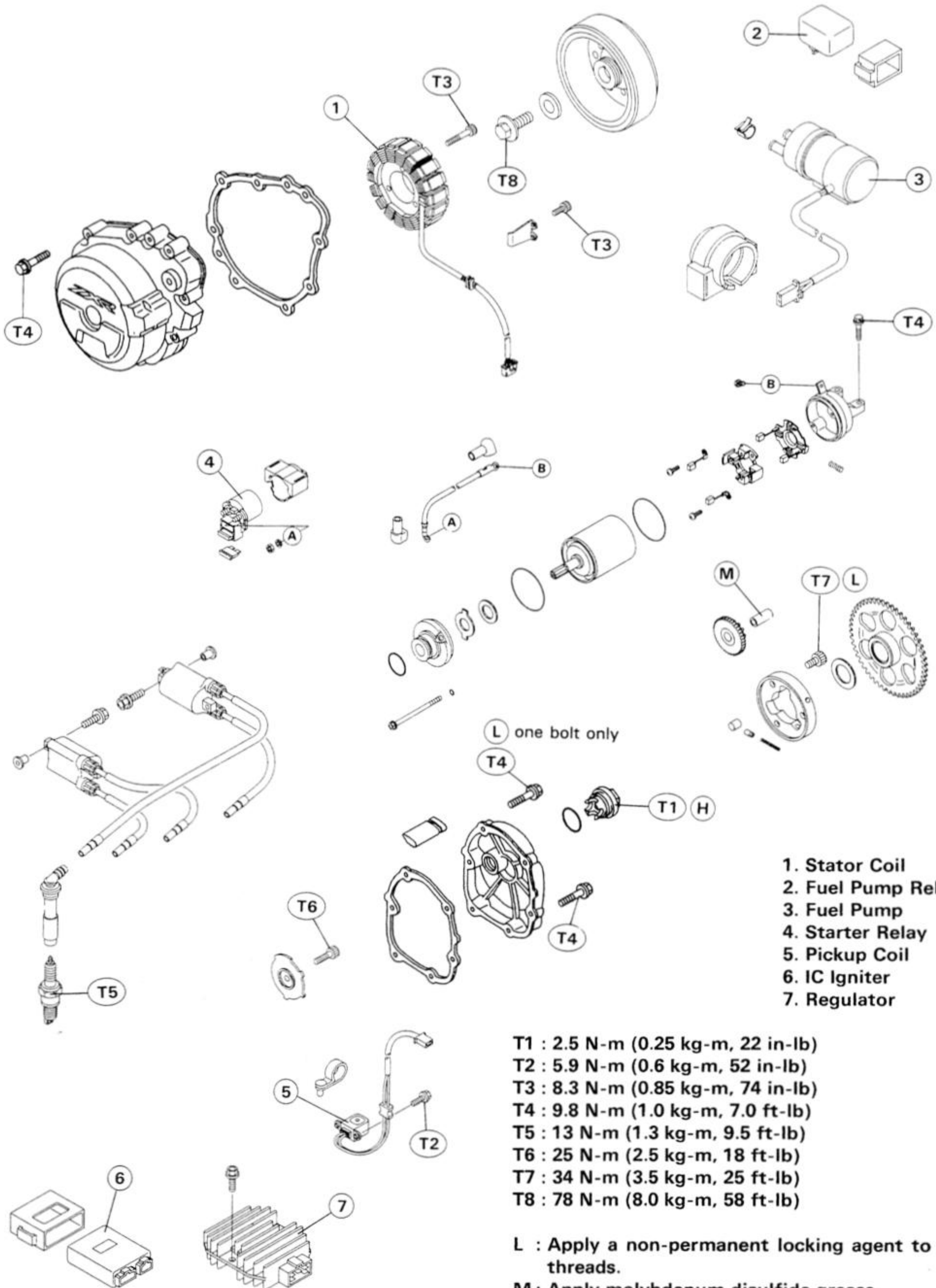

- 1. Stator Coil
- 2. Fuel Pump Relay
- 3. Fuel Pump
- 4. Starter Relay
- 5. Pickup Coil
- 6. IC Igniter
- 7. Regulator

- T1 : 2.5 N-m (0.25 kg-m, 22 in-lb)
- T2 : 5.9 N-m (0.6 kg-m, 52 in-lb)
- T3 : 8.3 N-m (0.85 kg-m, 74 in-lb)
- T4 : 9.8 N-m (1.0 kg-m, 7.0 ft-lb)
- T5 : 13 N-m (1.3 kg-m, 9.5 ft-lb)
- T6 : 25 N-m (2.5 kg-m, 18 ft-lb)
- T7 : 34 N-m (3.5 kg-m, 25 ft-lb)
- T8 : 78 N-m (8.0 kg-m, 58 ft-lb)

L : Apply a non-permanent locking agent to the threads.
 M : Apply molybdenum disulfide grease.
 H : Hand-Tight

15-4 ELECTRICAL SYSTEM

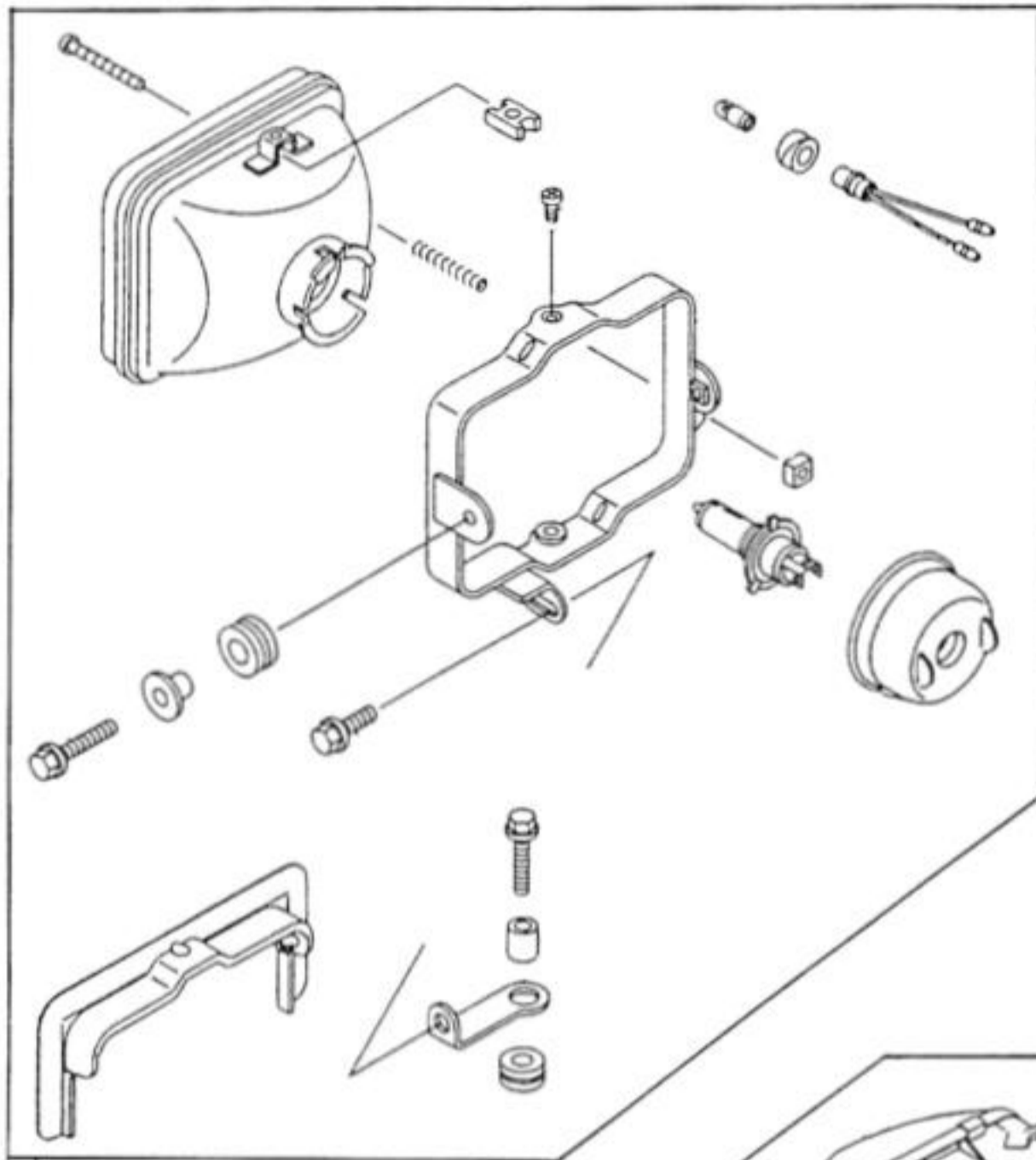

L1 Model
(other than UK)

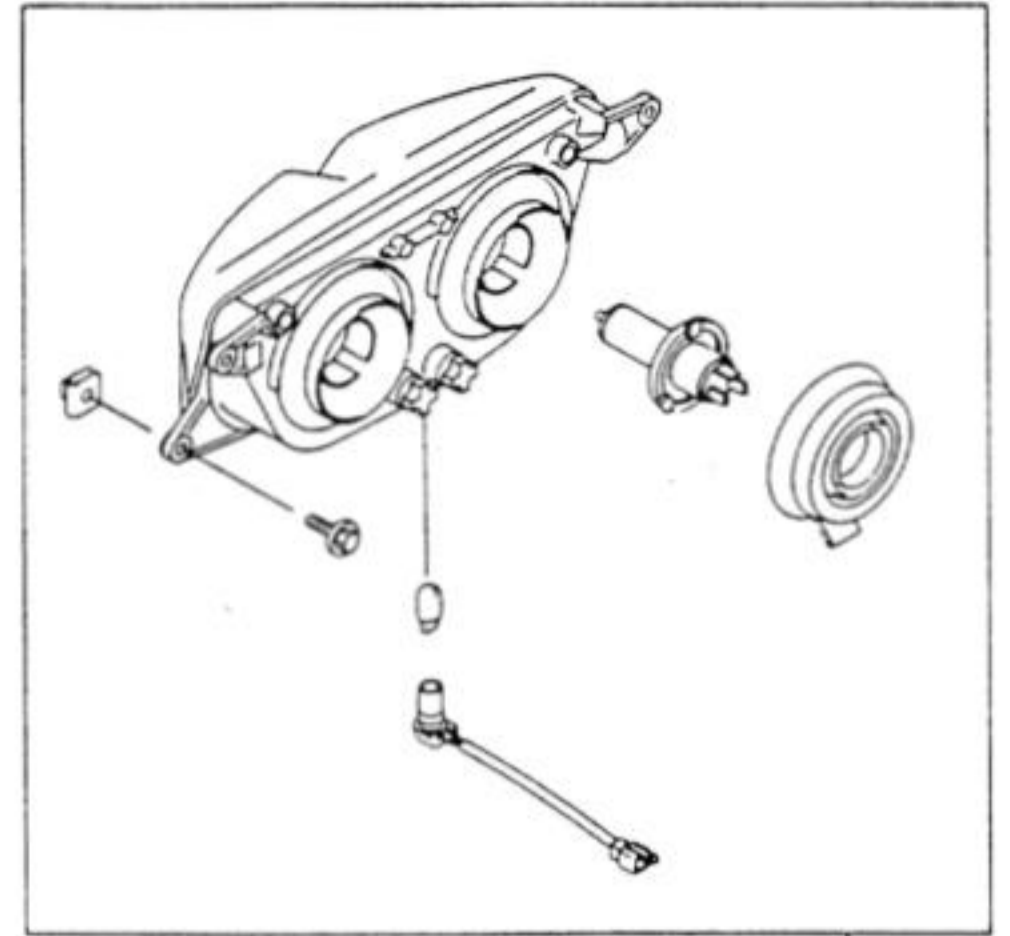

(UK)

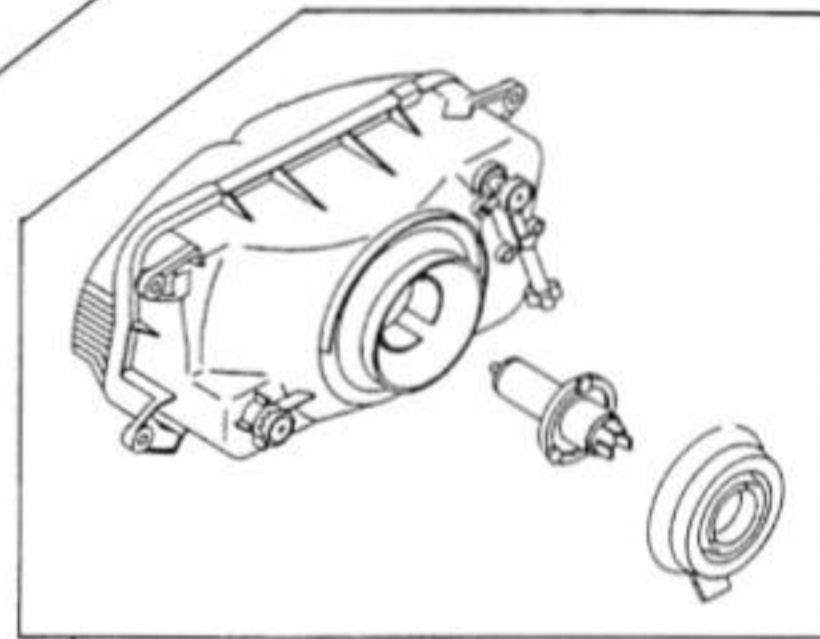

L1 ~ L5 Models
(other than UK)

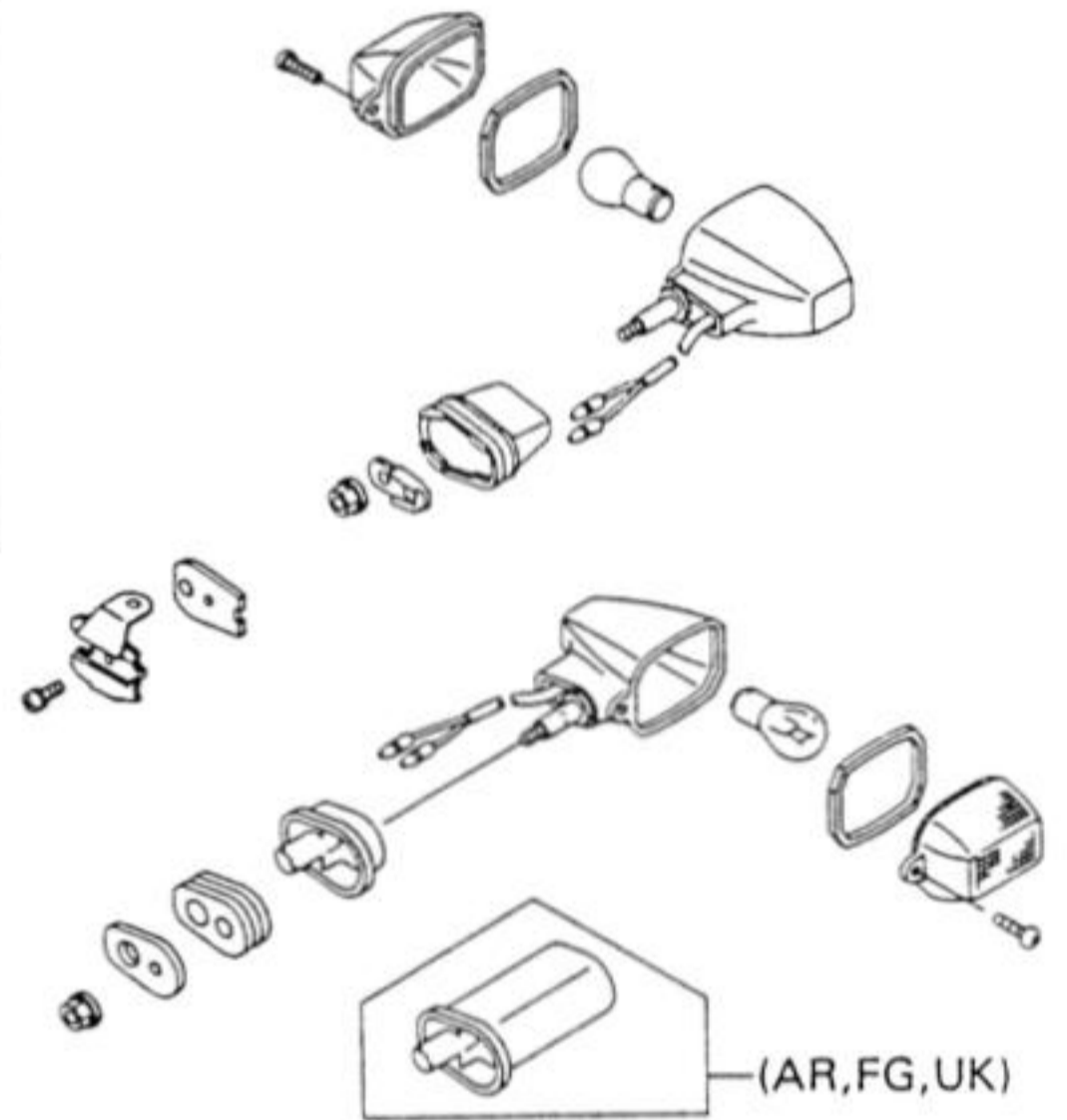

(AR,FG,UK)

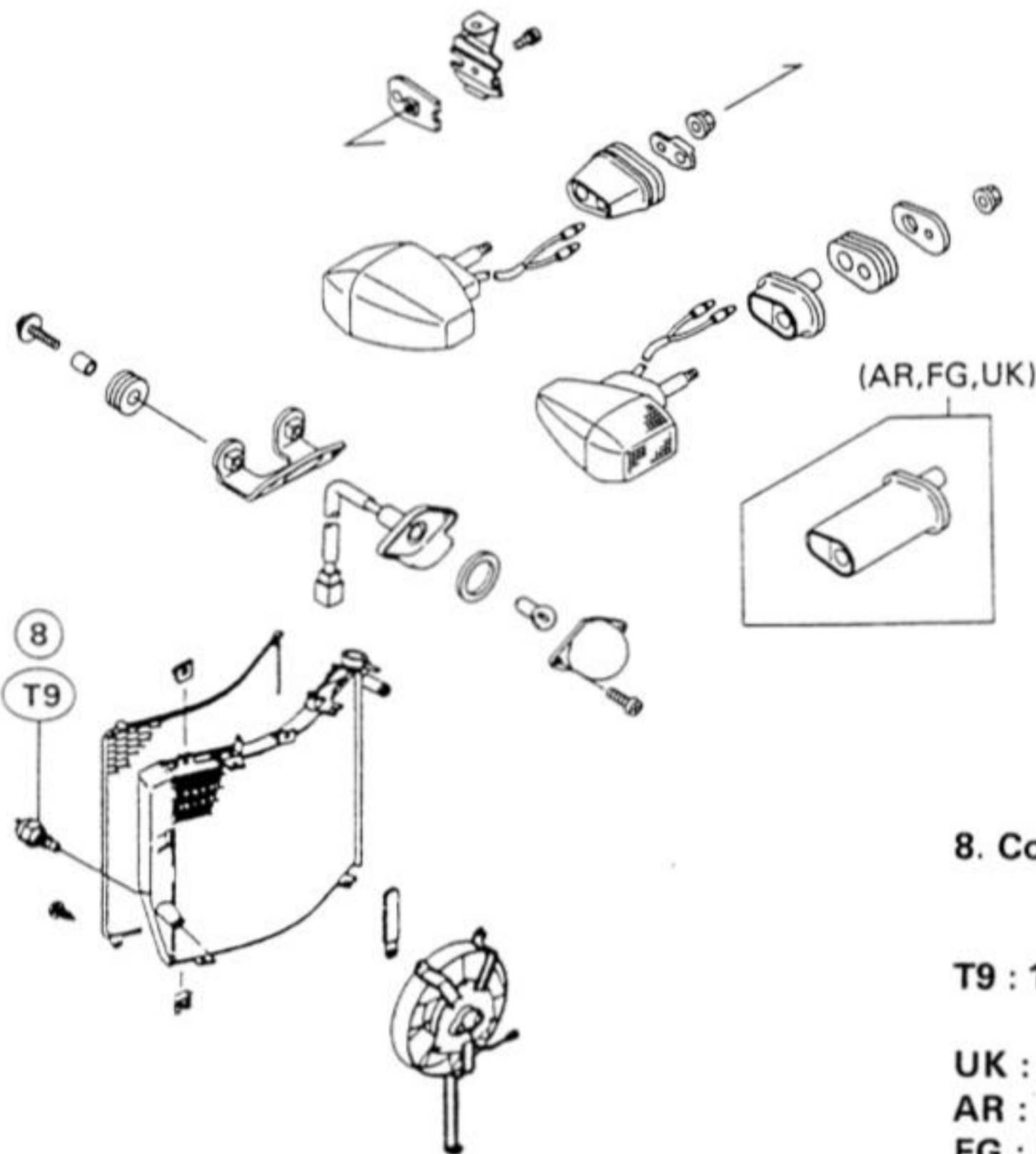

(AR,FG,UK)

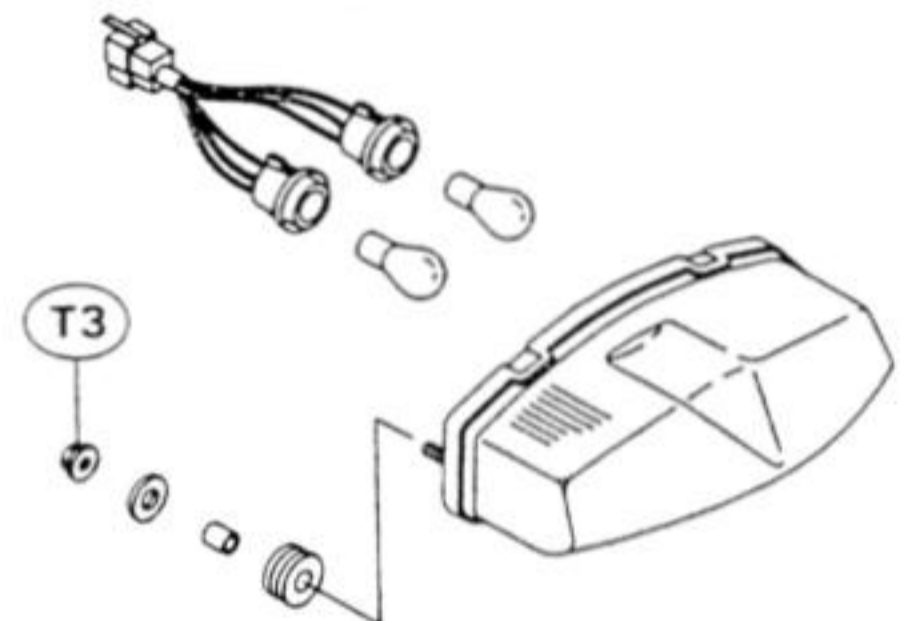

T3

8. Cooling Fan Switch

T9 : 18 N-m (1.8 kg-m, 13 ft-lb)

UK : U.K. Model
AR : Austrian Model
FG : German Model

ELECTRICAL SYSTEM 15-5

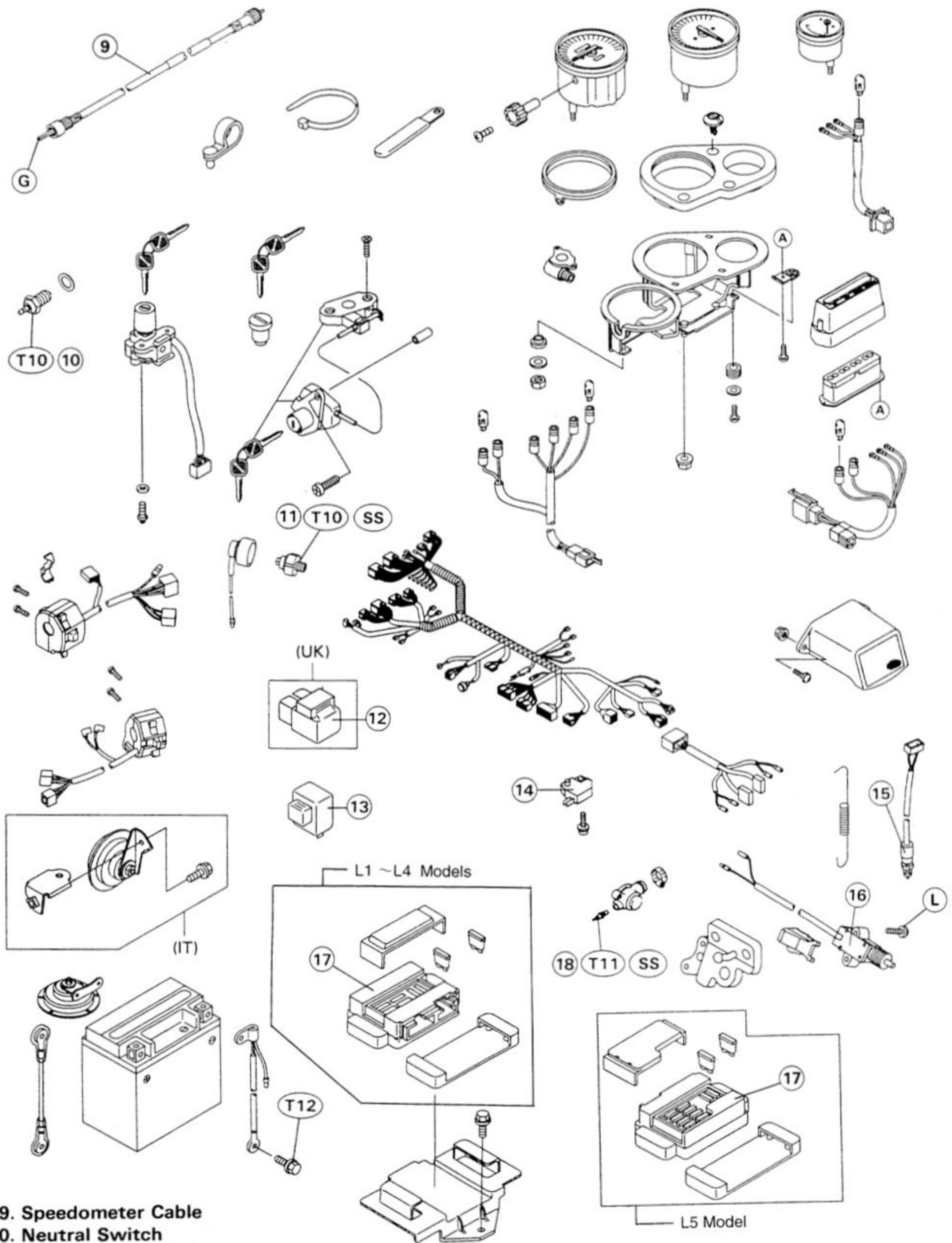

- 9. Speedometer Cable
- 10. Neutral Switch
- 11. Oil Pressure Switch
- 12. Headlight Relay
- 13. Turn Signal Relay
- 14. Front Brake Light Switch
- 15. Rear Brake Light Switch
- 16. Side Stand Switch
- 17. Junction Box
- 18. Water Temperature Sensor

T10 : 15 N-m (1.5 kg-m, 11 ft-lb)
T11 : 7.8 N-m (0.8 kg-m, 69 in-lb)
T12 : 9.8 N-m (1.0 kg-m, 7.0 ft-lb)
G : Apply grease.
IT : Italian Model

15-6 ELECTRICAL SYSTEM

Specifications

Item	Standard	Service Limit
Battery: Type Specific gravity	12 V 8 Ah 1.32 @20°C (68°F)	--- ---
Alternator: Charging voltage Output voltage Stator coil resistance	14.5 V Night @4 000 r/min (rpm) Not less than 43 V @4 000 r/min (rpm) 0.2 ~ 0.9 Ω	--- --- ---
Ignition System: Pickup coil resistance Ignition coil: 3 needle arcing distance Primary winding resistance Secondary winding resistance Spark plug gap	355 ~ 535 Ω 7 mm or more 2.3 ~ 3.5 Ω 12 ~ 18 kΩ 0.7 ~ 0.8 mm	--- --- --- --- ---
Starter Motor: Carbon brush length Commutator groove depth Commutator diameter	7 mm 0.45 ~ 0.75 mm 24 mm	3.5 mm 0.2 mm 23 mm
Fuel Pump: Fuel pump pressure	11 ~ 16 kPa (0.11 ~ 0.16 kg/cm ² , 1.6 ~ 2.3 psi)	---
Switches and Sensors: Rear brake light switch Fan switch: OFF → ON ON → OFF Water temperature sensor resistance	ON after about 10 mm pedal travel 84 ~ 90°C (183 ~ 194°F) 71 ~ 77°C (160 ~ 170°F) 80°C (175°F) : 47 ~ 57 Ω 100°C (212°F) : 25 ~ 30 Ω	--- --- --- ---

Special Tools

Hand Tester: 57001-1394

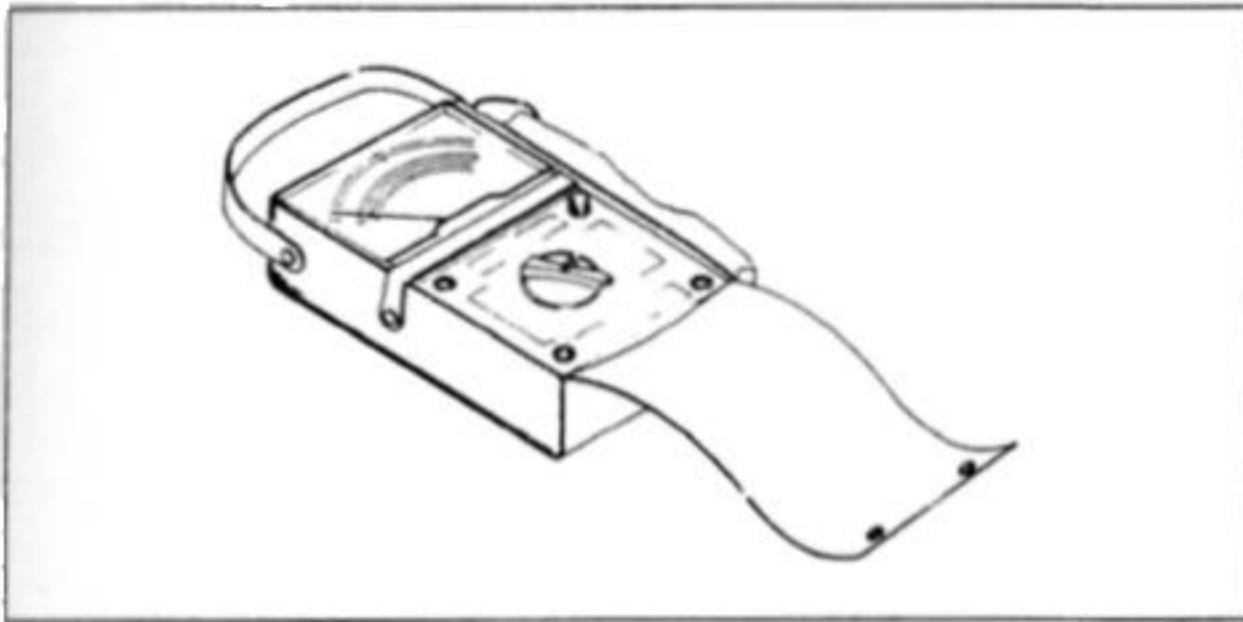

Flywheel Holder: 57001-1313

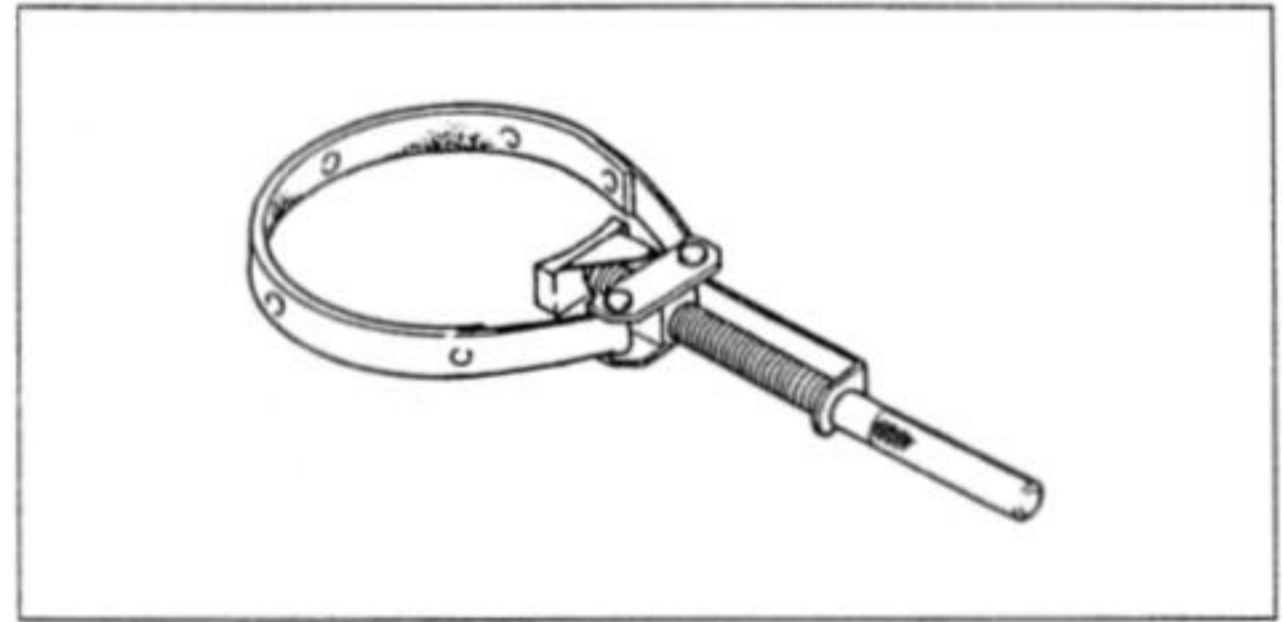

Coil Tester: 57001-1242

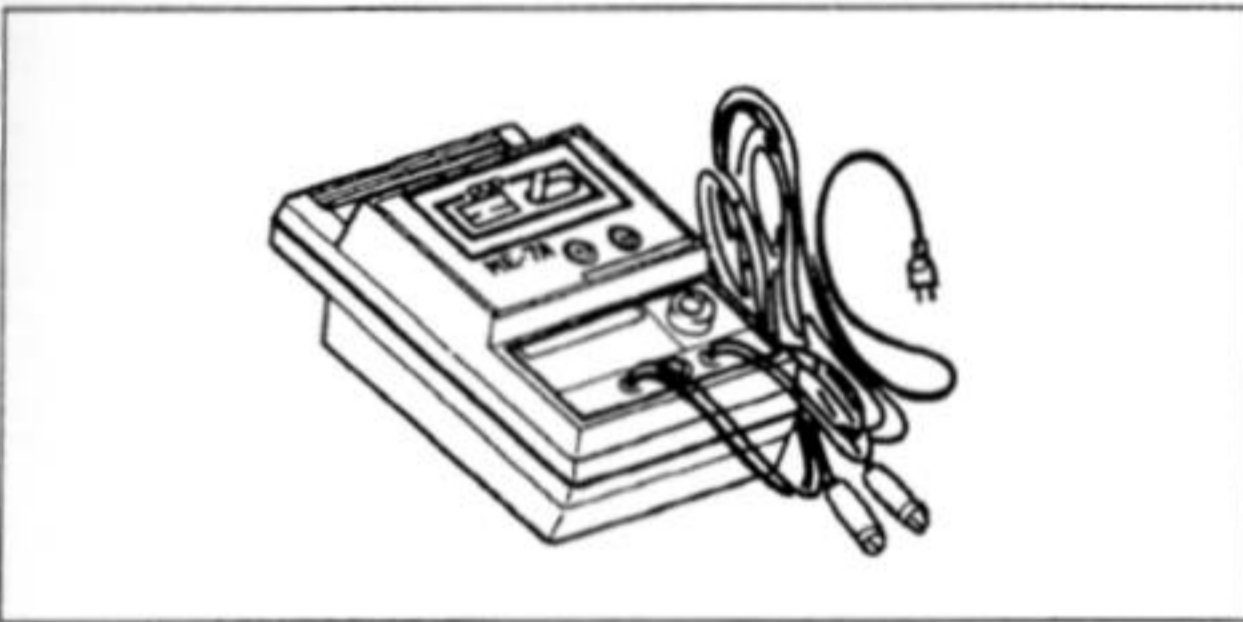

Rotor Puller, M16/M18/M20/M22 x 1.5: 57001-1216

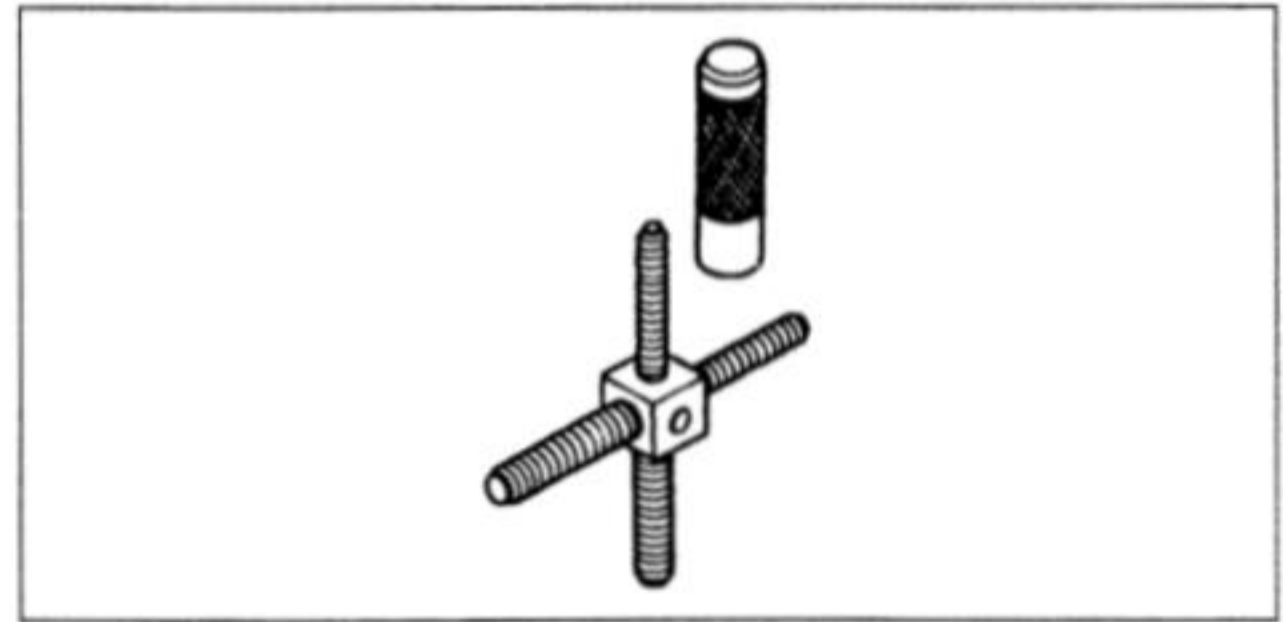

Spark Plug Wrench, Hex 16: 57001-1262

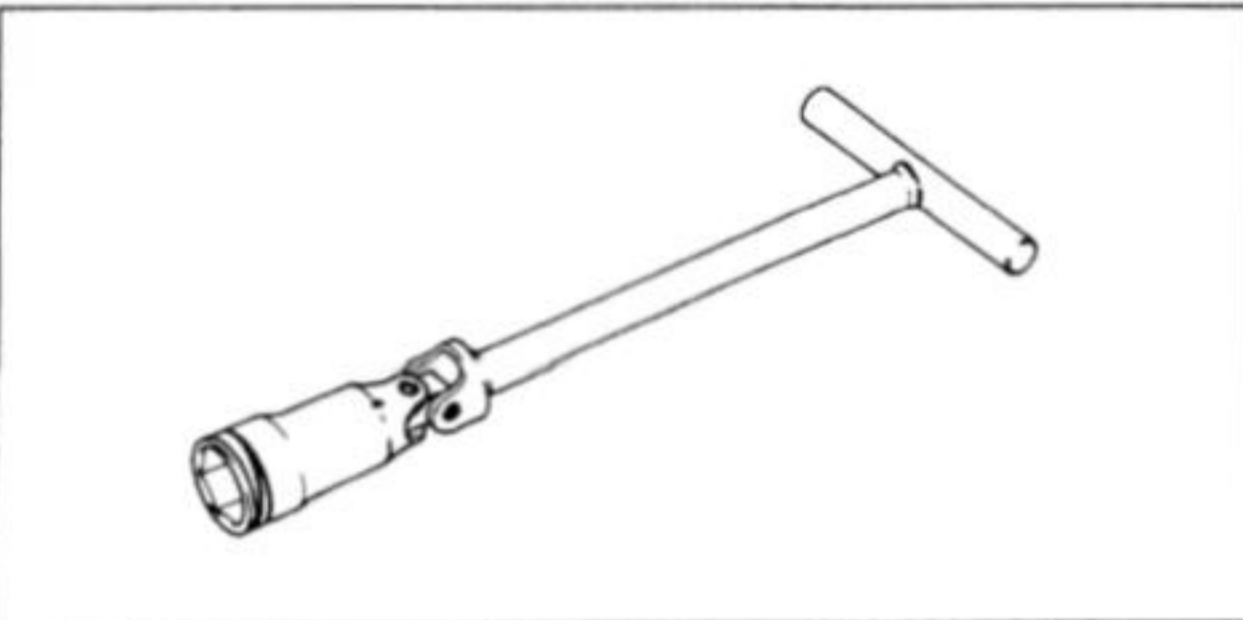

Rotor Puller, M33 x 1.5: 57001-1277

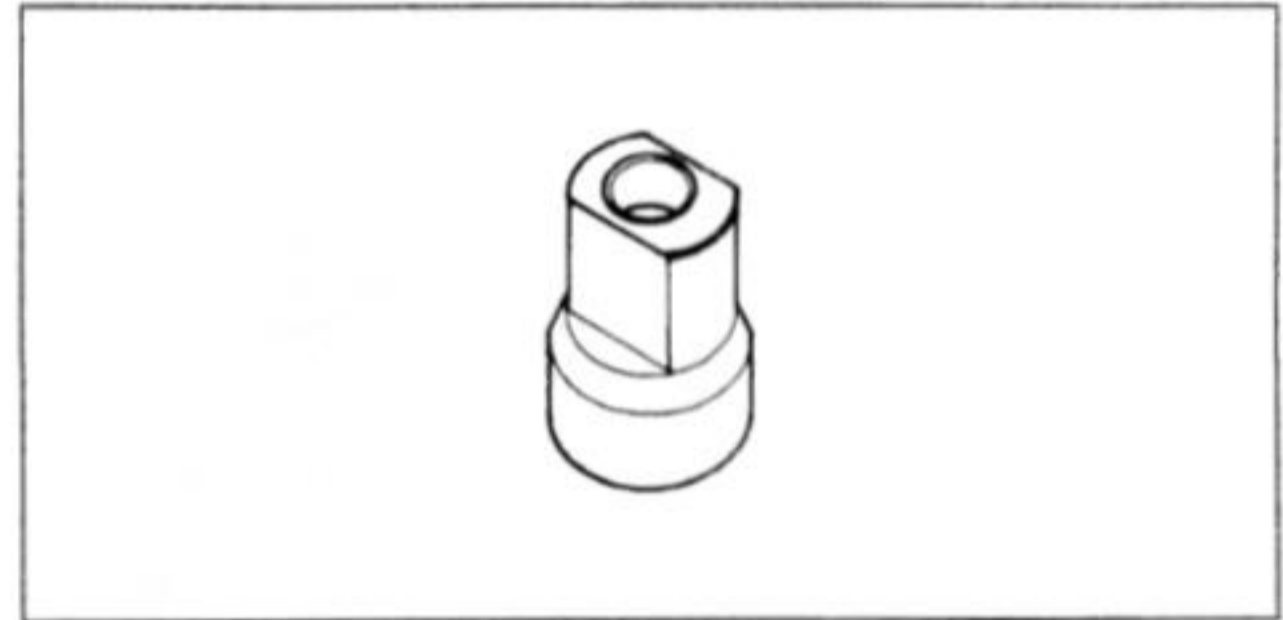

Socket Wrench, Hex 8: 57001-1268

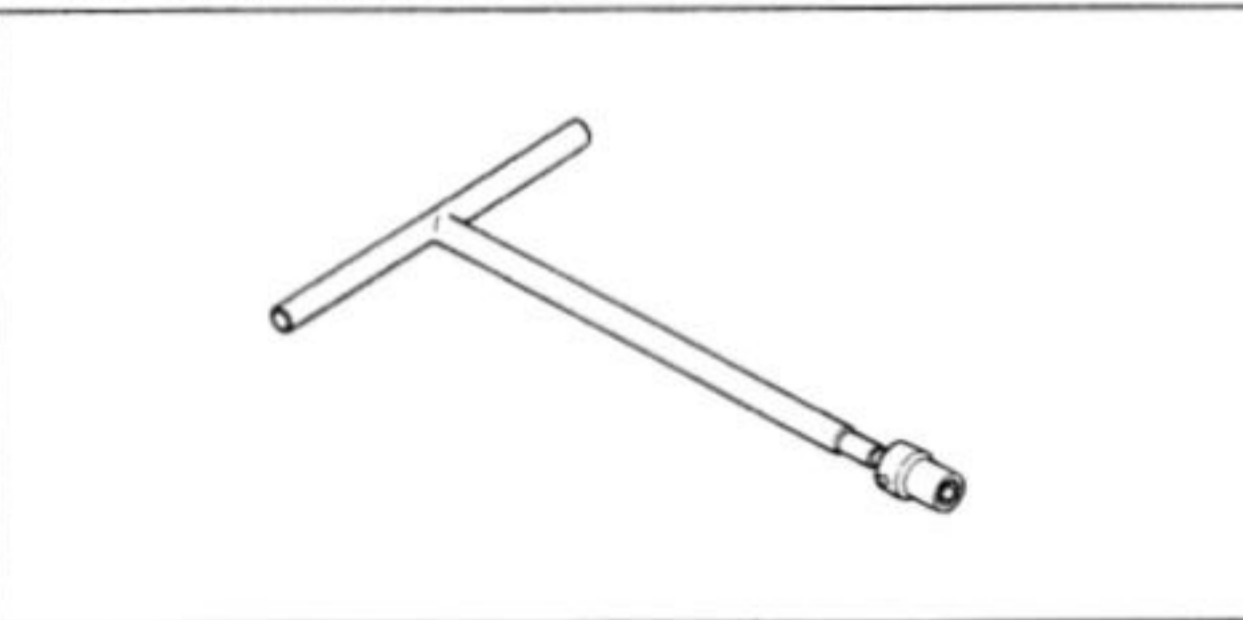

Sealant

Kawasaki Bond (Silicone Sealant): 56019-120

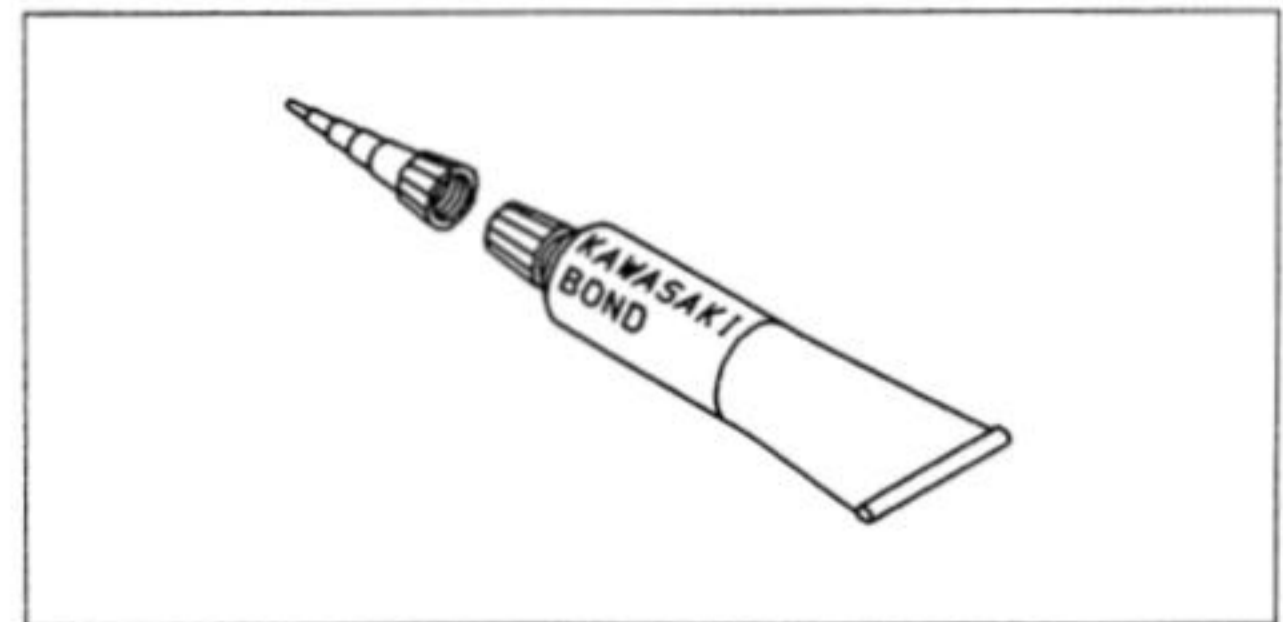

Jack: 57001-1238

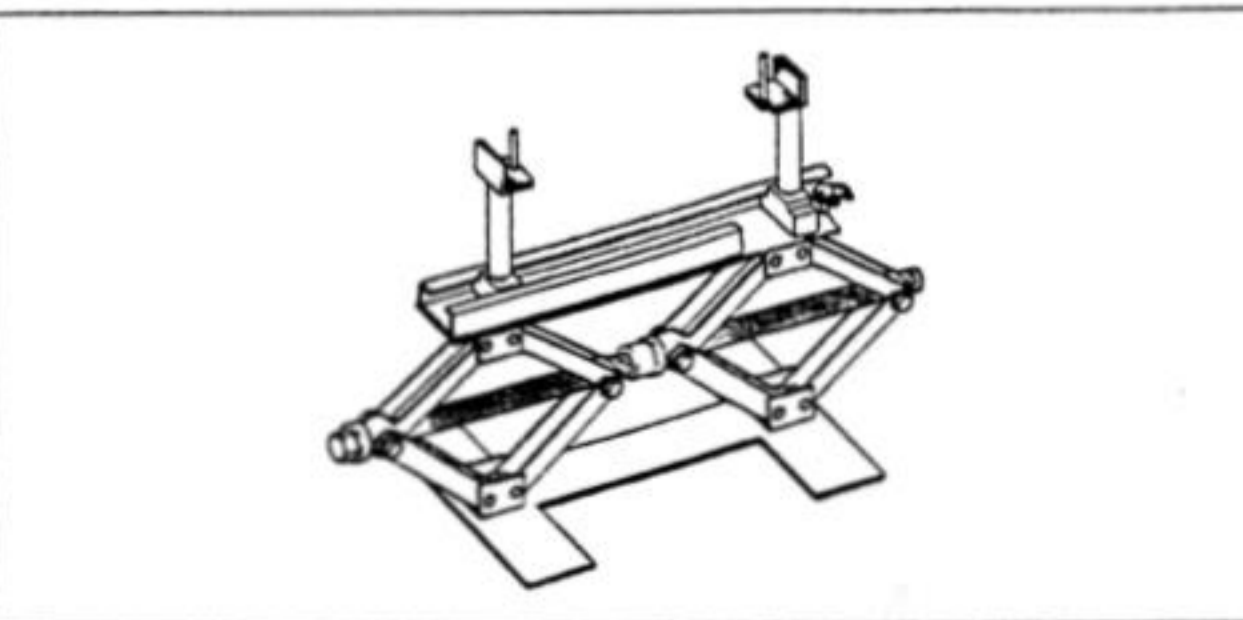

15-8 ELECTRICAL SYSTEM

Parts Location

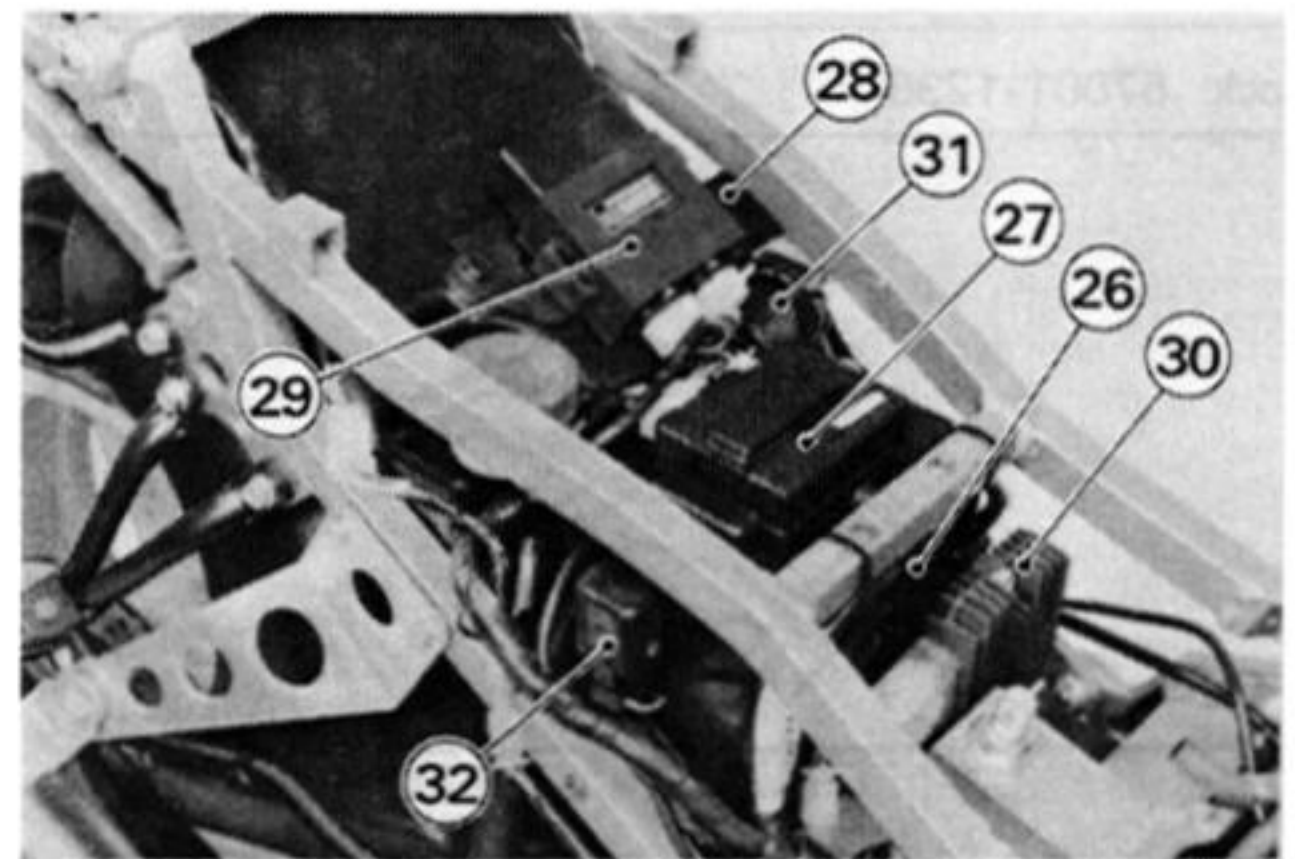
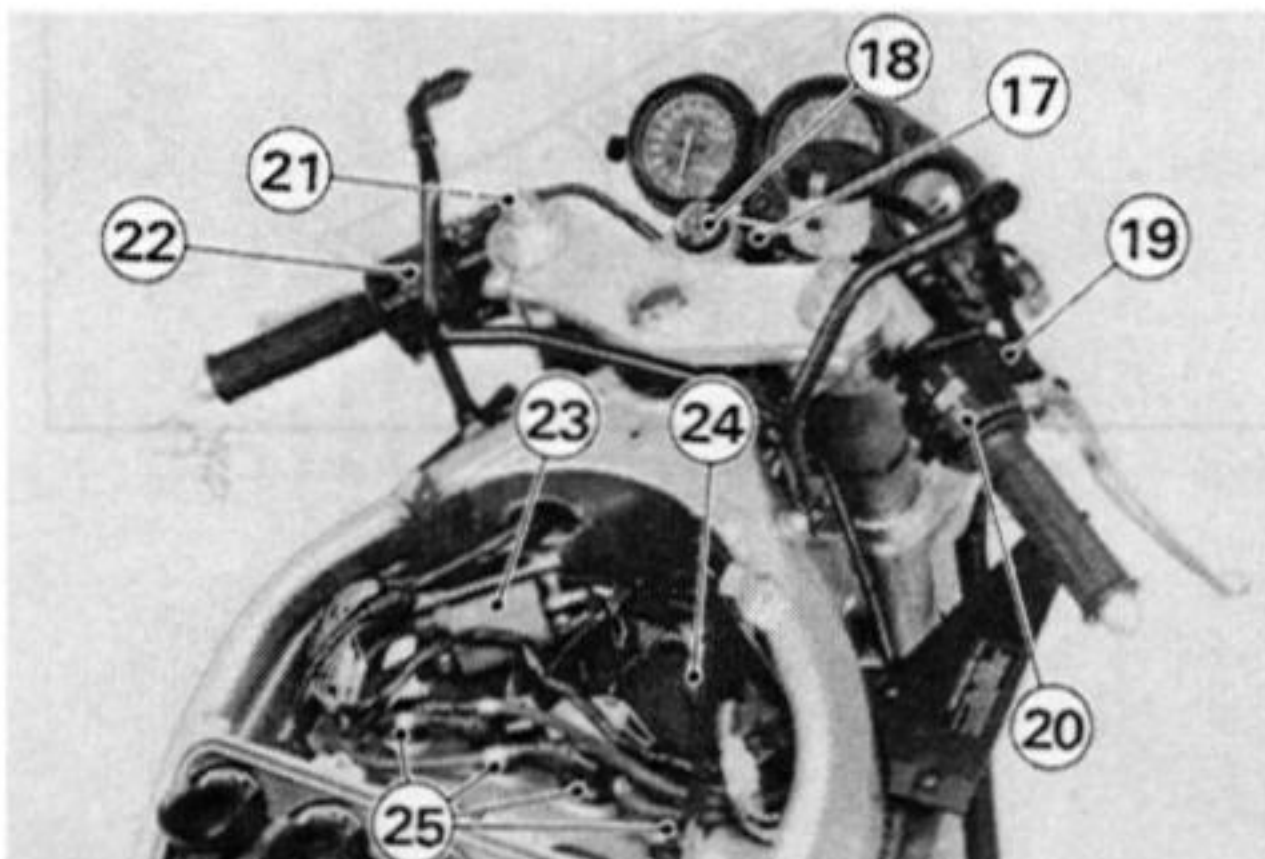
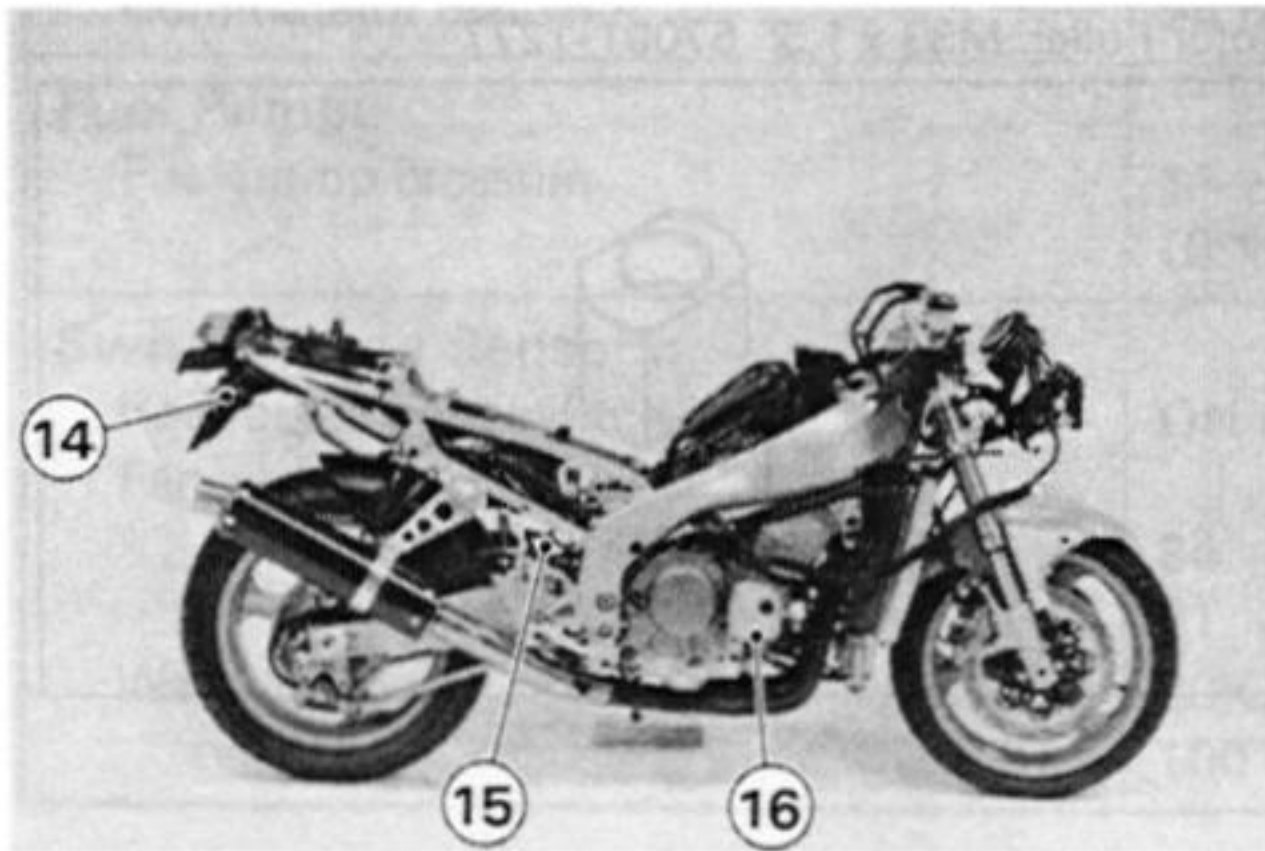
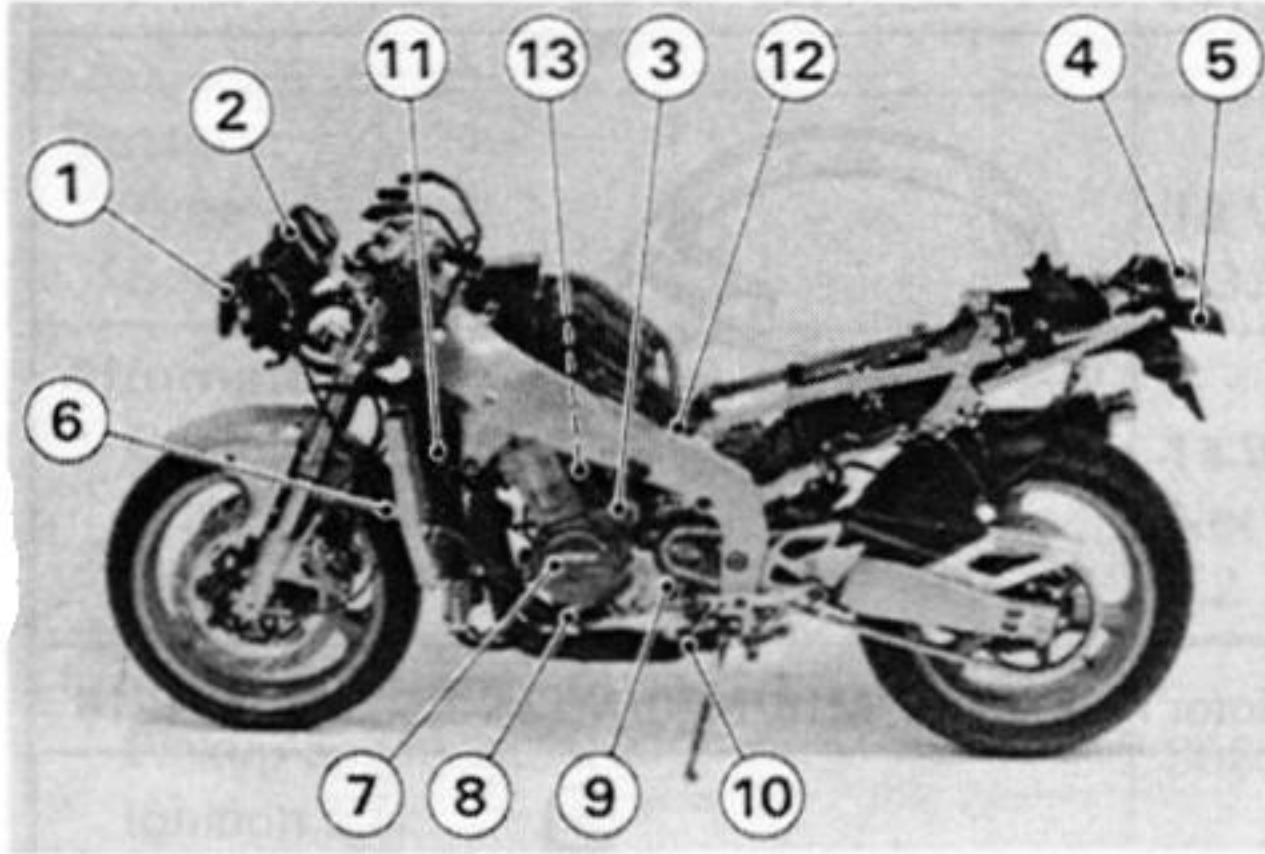

1. Headlight Unit
2. Meter Unit
3. Starter Motor
4. Tail/Brake Light
5. License Light
6. Fan Switch
7. Alternator
8. Oil Pressure Switch
9. Neutral Switch
10. Side Stand Switch
11. Cooling Fan
12. Fuel Pump
13. Water Temperature Sensor
14. Turn Signal Light
15. Rear Brake Light Switch
16. Pickup Coil
17. Indicator Light
18. Ignition Switch
19. Front Brake Light Switch
20. Right Grip Switch
21. Starter Lockout Switch
22. Left Grip Switch
23. Ignition Coil (#2, 3)
24. Ignition Coil (#1, 4)
25. Spark Plugs
26. Battery
27. Junction Box
28. Fuel Pump Relay
29. IC Igniter
30. Regulator/Rectifier
31. Starter Relay
32. Turn Signal Relay

Wiring Diagram (ZX400-L1 ~ L4)

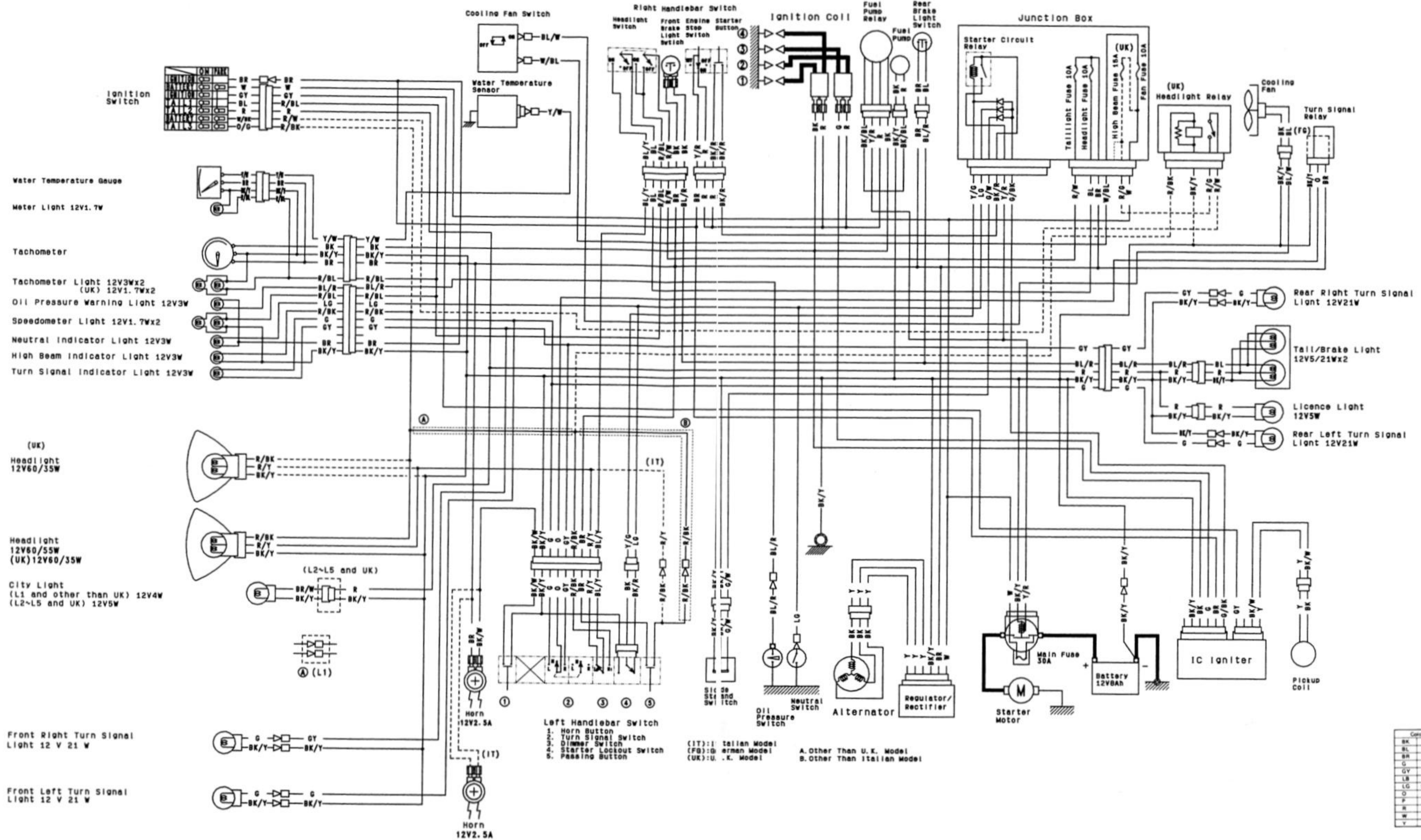

- Water Temperature Gauge
- Meter Light 12V1.7W
- Tachometer
- Tachometer Light 12V3Wx2 (UK) 12V1.7Wx2
- Oil Pressure Warning Light 12V3W
- Speedometer Light 12V1.7Wx2
- Neutral Indicator Light 12V3W
- High Beam Indicator Light 12V3W
- Turn Signal Indicator Light 12V3W

- (UK) Headlight 12V60/35W
- Headlight 12V60/55W (UK) 12V60/35W
- City Light (L1 and other than UK) 12V4W (L2~L5 and UK) 12V5W

- Front Right Turn Signal Light 12 V 21 W
- Front Left Turn Signal Light 12 V 21 W

- Left Handbar Switch
1. Horn Button
 2. Turn Signal Switch
 3. Dimmer Switch
 4. Starter Lockout Switch
 5. Passing Button

(IT): Italian Model
 (FB): German Model
 (UK): U. K. Model
 A. Other Than U. K. Model
 B. Other Than Italian Model

BK	Black
BL	Blue
BR	Brown
G	Green
GY	Grey
LB	Light Blue
LG	Light Green
O	Orange
P	Pink
R	Red
W	White
Y	Yellow

Horn Button		Turn Signal Switch			Dimmer Switch			Starter Lockout Switch			Passing Button						
Color	BK/W	BK/Y	Color	G	O	GY	Color	R/Y	BL/Y	R/BK	Color	BK/Y	BK	BK/R	Color	BR	R/BK
Push	○	○	L	○	○	○	Clutch Lever	○	○	○	Push	○	○	○	Push	○	○
			R	○	○	○	Released	○	○	○		○	○	○		○	○
				○	○	○	Pulled in	○	○	○		○	○	○		○	○

	Ignition	Battery	Ignition	Tail 1	Tail 2	Battery	Tail 3
Color	BR	W	GY	BL	R	W/BK	O/G
ON	○	○	○	○	○	○	○
OFF/LOCK	○	○	○	○	○	○	○
ON V	○	○	○	○	○	○	○
PAR	○	○	○	○	○	○	○

Headlight Switch			Front Brake Light Switch		Engine Stop Switch		Starter Button			
Color	BL/Y	BL	R/BL	R/W	Color	BK	BK	Color	BK/R	BK/R
OFF	○	○	○	○	OFF	○	○	Push	○	○
ON	○	○	○	○	OFF	○	○	Push	○	○
	○	○	○	○	OFF	○	○	Push	○	○
	○	○	○	○	OFF	○	○	Push	○	○

15-10 ELECTRICAL SYSTEM

Wiring Diagram (ZX400-L5)

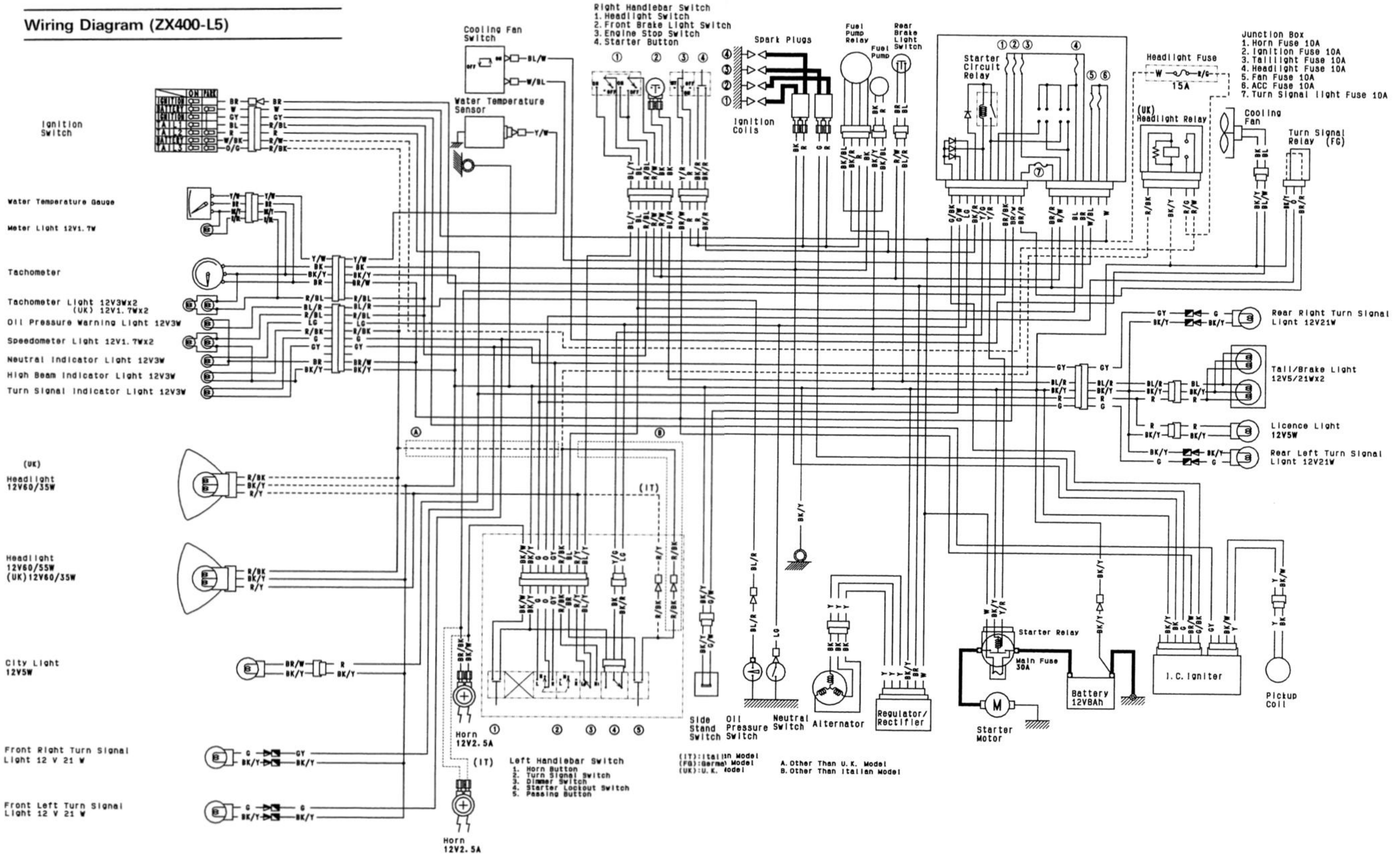

Color Code

BK	Black
BL	Blue
BR	Brown
G	Green
GY	Grey
LB	Light Blue
LG	Light Green
O	Orange
P	Pink
R	Red
W	White
Y	Yellow

LEFT HANDLEBAR SWITCH CONNECTIONS

Horn Button		Turn Signal Switch			Dimmer Switch			Starter Lockout Switch			Passing Button						
Color	BK/W	BK/Y	Color	G	O	GY	Color	R/Y	BL/Y	R/BK	Color	BK/Y	BK	BK/R	Color	BR	R/BK
			L				HI				Clutch Lever						
Push			OFF(Push)				Released				Released				Push		
			R				Pulled in				Pulled in						

IGNITION SWITCH CONNECTIONS

	Ignition	Battery	Ignition	Tail 1	Tail 2	Battery	Tail 3
Color	BR	W	GY	BL	R	W/BK	O/G
OFF, LOCK							
ON	●	●	●	●	●	●	●
PARK	●	●	●	●	●	●	●

RIGHT HANDLEBAR SWITCH CONNECTIONS

Headlight Switch		Front Brake Light Switch		Engine Stop Switch		Starter Button				
Color	BL/Y	BL	R/BL	R/W	Color	BK	BK	Color	BK/R	BK/R
OFF					Color <td>Y/R</td> <td>R</td> <td>Color <td>BK/R</td> <td>BK/R</td> </td>	Y/R	R	Color <td>BK/R</td> <td>BK/R</td>	BK/R	BK/R
OFF	○	○	○	○	Brake Lever	OFF		Color <td>BK/R</td> <td>BK/R</td>	BK/R	BK/R
ON	●	●	●	●	Pulled in	○		Color <td>BK/R</td> <td>BK/R</td>	BK/R	BK/R
					RUN	●		Color <td>BK/R</td> <td>BK/R</td>	BK/R	BK/R

15-12 ELECTRICAL SYSTEM

Battery Standard Charge Time Chart (0.9 A Regular Current Charge) - For Reference

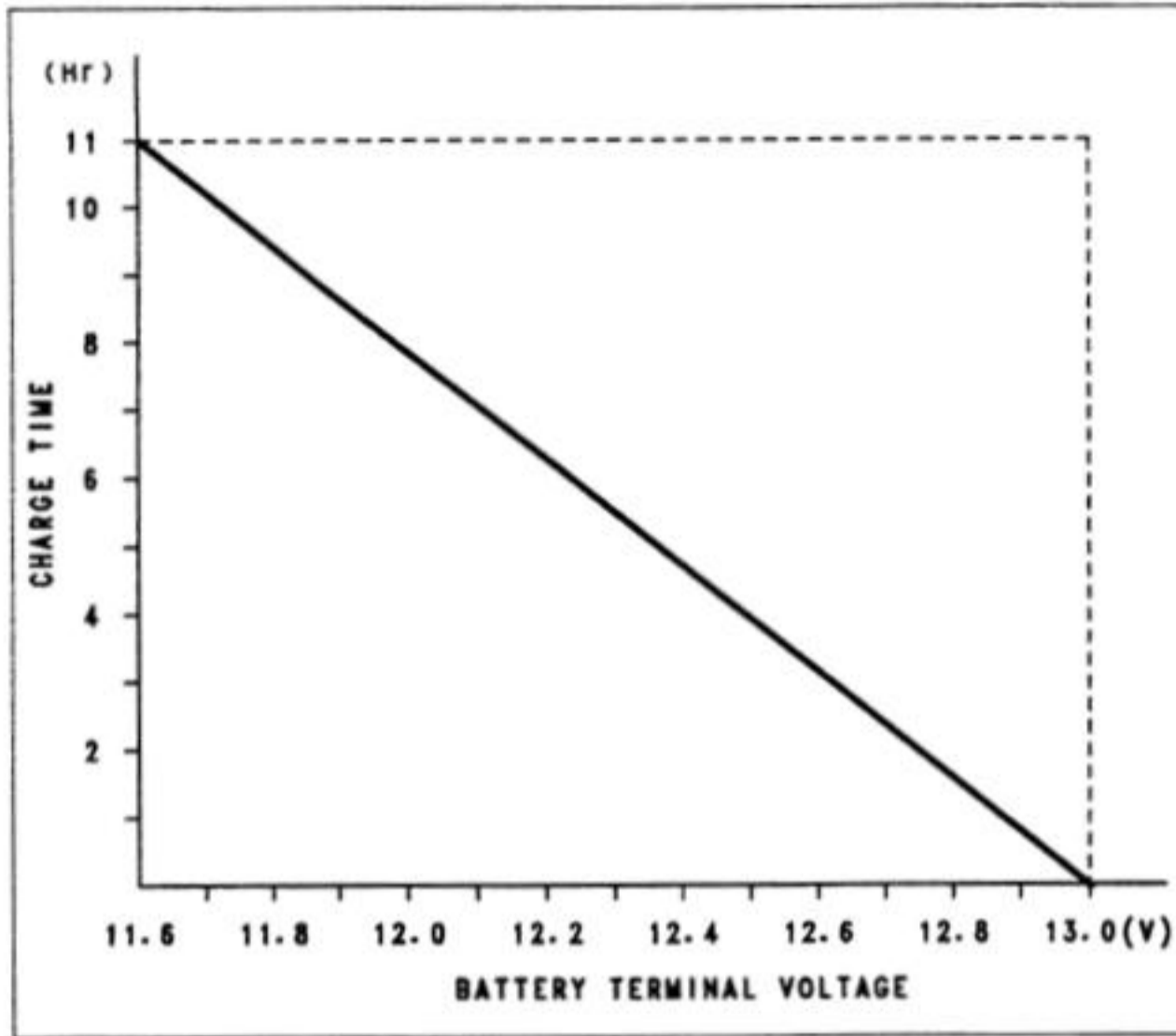

- Determine battery condition after refreshing charge.
- Determine the condition of the battery 30 minutes after completion of the charge by measuring the terminal voltage according to the table below.

Criteria	Judgement
12.6 V or higher	Good
12.0 ~ 12.6 V or lower	Charge insufficient → Recharge.
12.0 V or lower	Unserviceable → Replace.

Charging System

Alternator Cover Removal

- Remove the lower fairing.
- Set a suitable container under the engine.
- Remove the alternator cover bolts, using the socket wrench (special tool: 57001-1268).

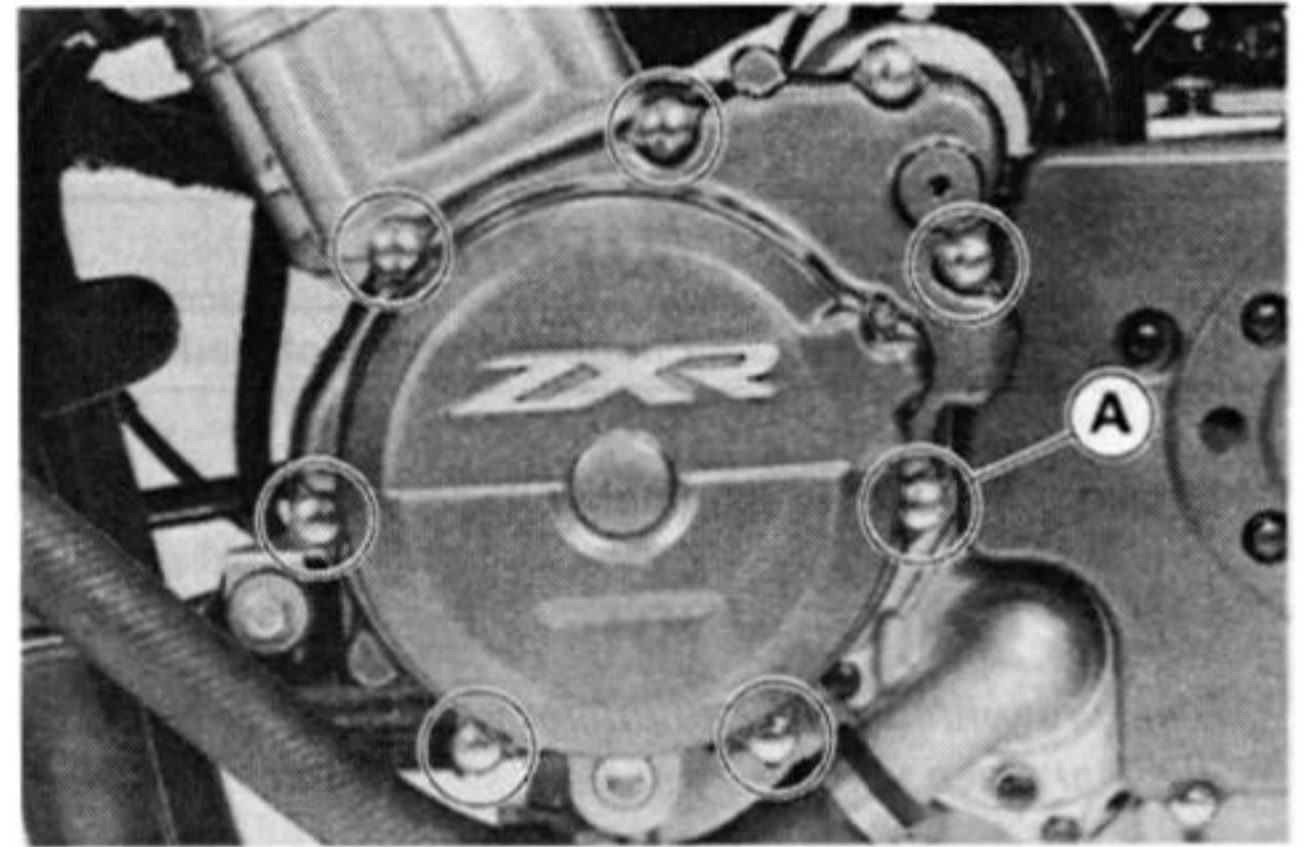

A. Alternator Cover Bolt

- Remove the alternator cover.

Alternator Cover Installation

- Replace the gasket with a new one.
- Run the stator lead as shown.
- Apply silicone sealant to the stator lead grommet.

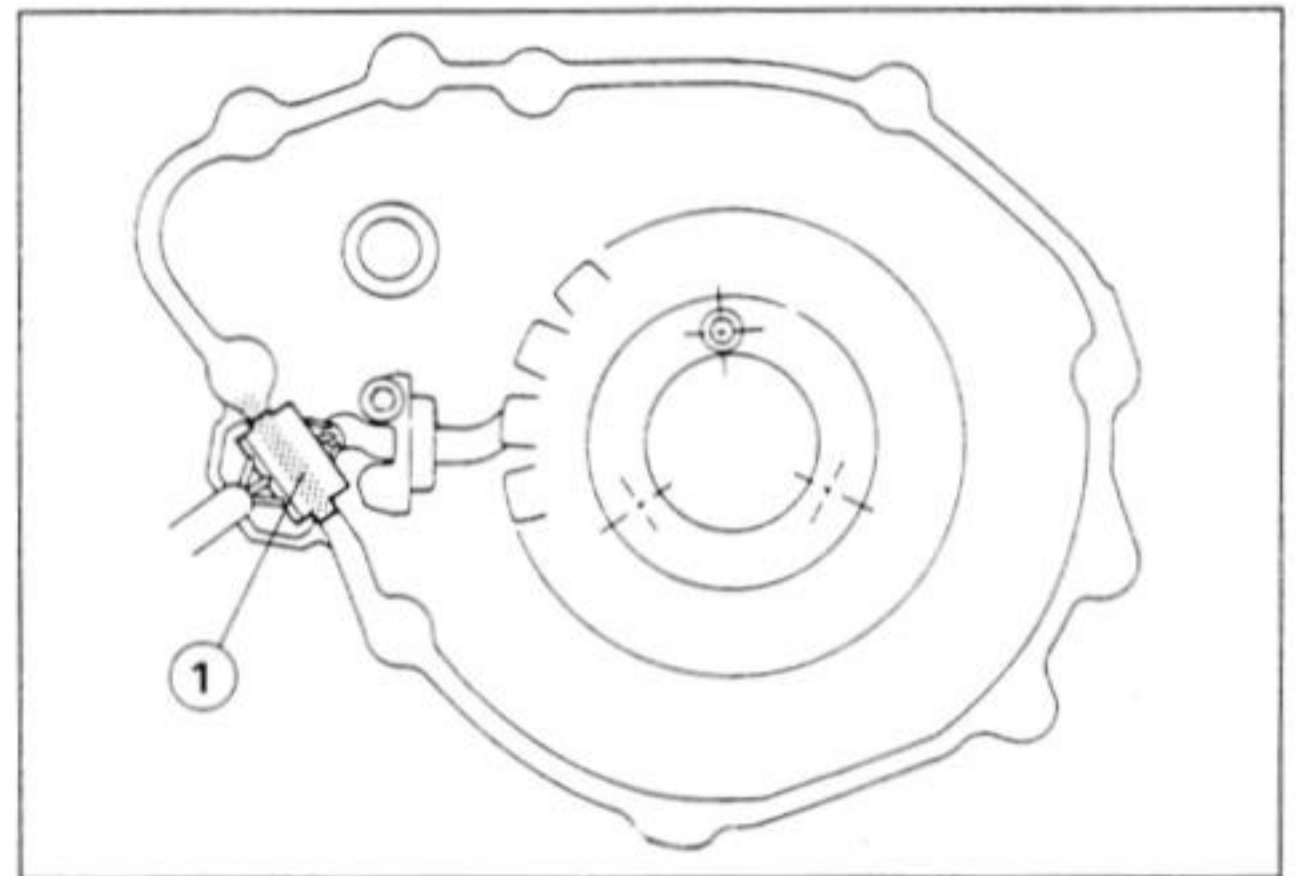

1. Apply silicone sealant

- Apply silicone sealant to the crankcase halves mating surface on the front and rear sides of the cover mount.

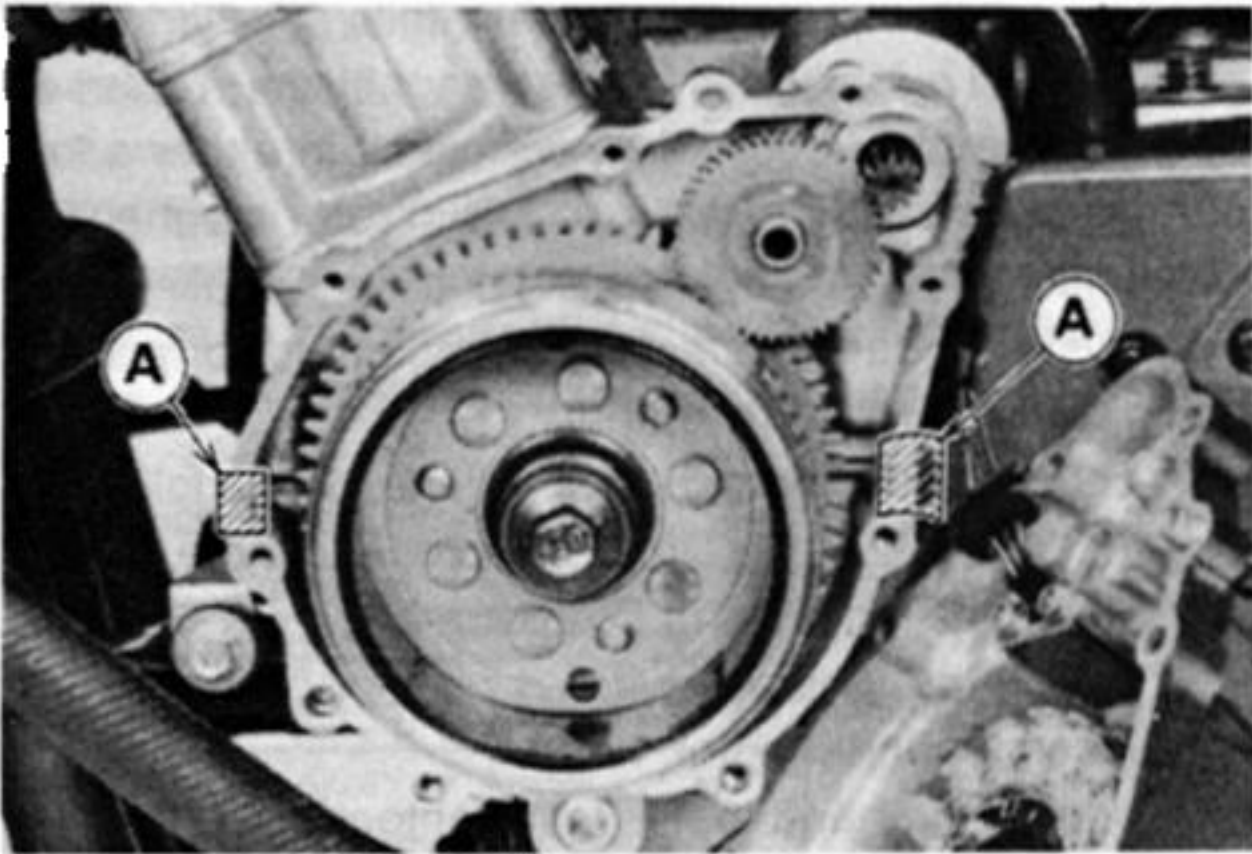

A. Silicone Sealant Applied Area

Alternator Rotor Removal

- Place the jack (special tool) under the frame to steady the motorcycle.
- Place a suitable container under the alternator cover.
- Remove the alternator cover.
- Wipe oil off the outer circumference of the rotor.
- Hold the alternator rotor steady with the flywheel holder (special tool), and remove the rotor bolt.

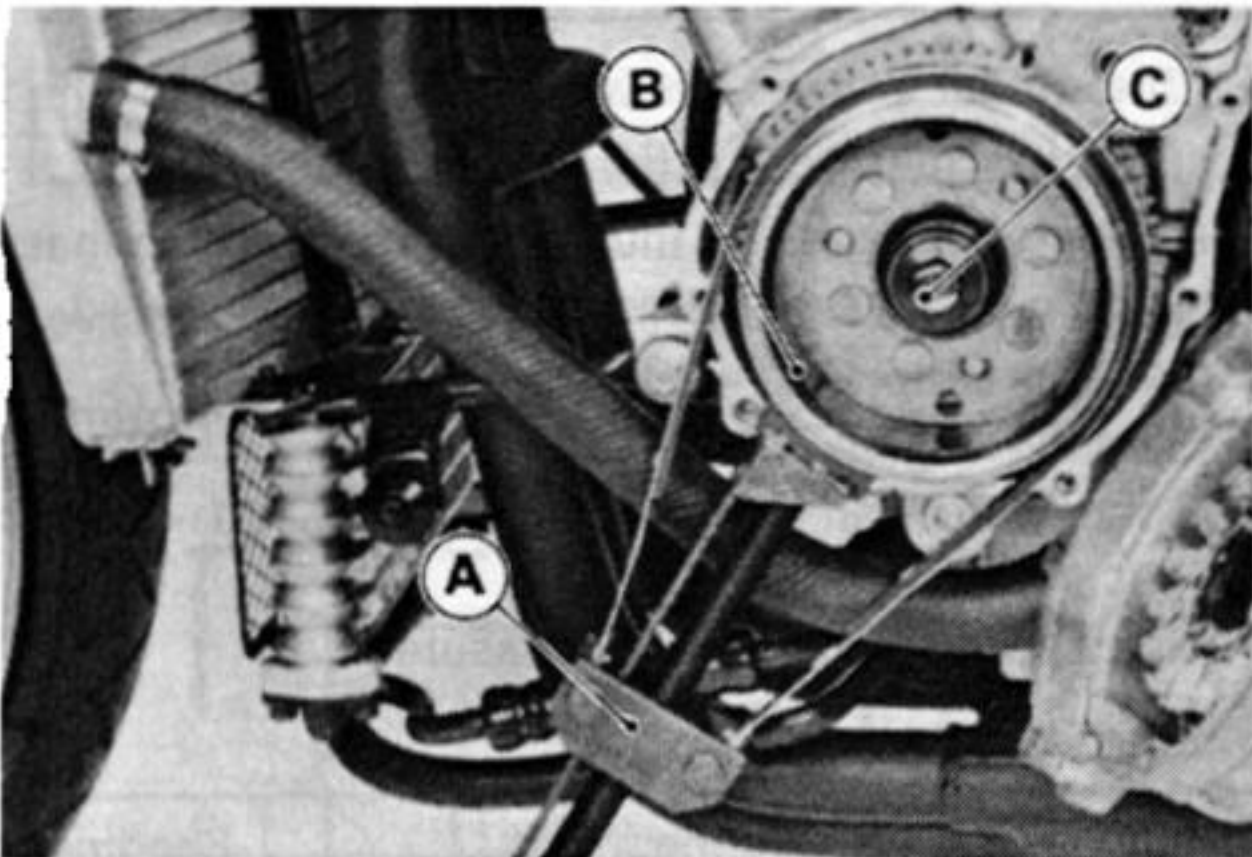

A. Flywheel Holder: 57001-1313 C. Rotor Bolt
B. Rotor

- Threads the rotor puller (special tool) and the rotor puller (special tool) onto the alternator rotor.
- Holding the rotor puller, turn the rotor puller until the alternator rotor is forced off the end of the crankshaft.

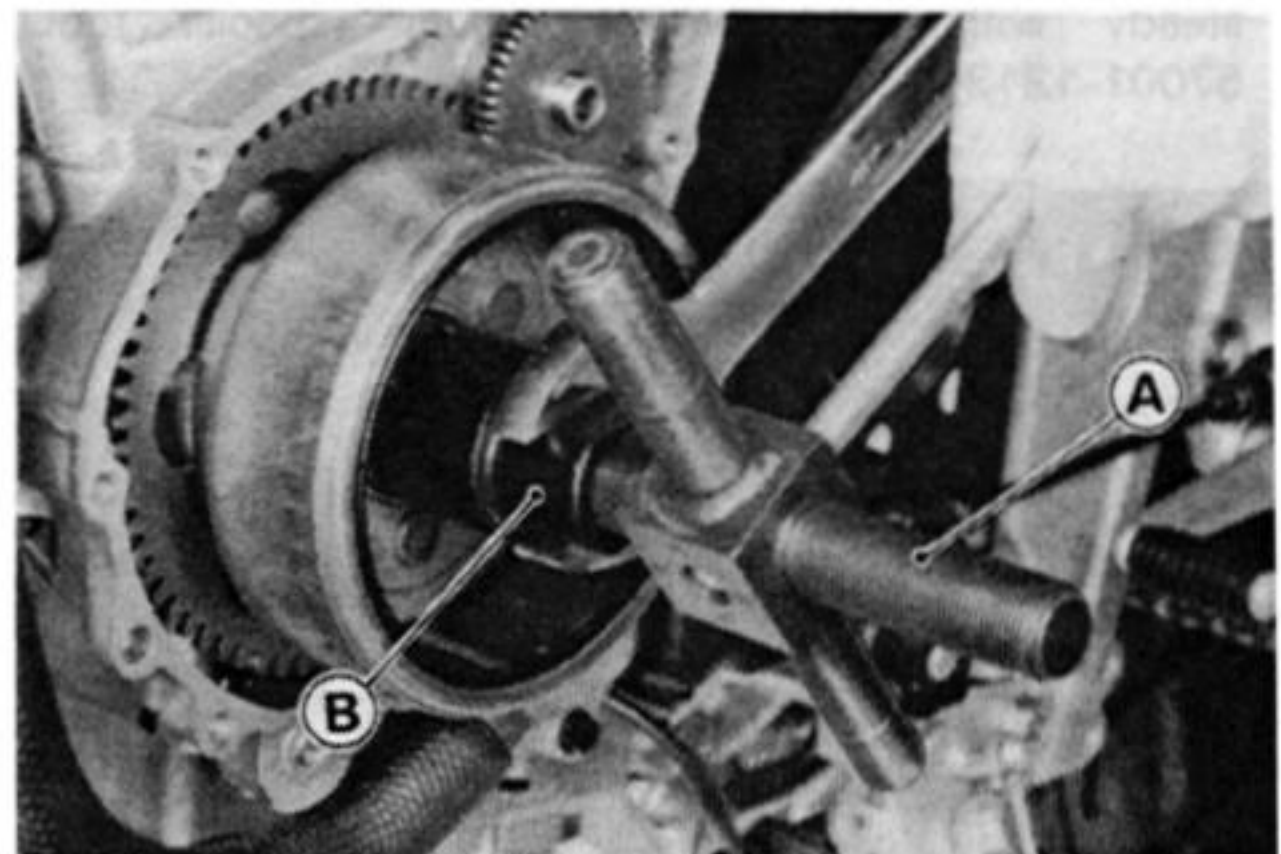

A. Rotor Puller: 57001-1216
B. Rotor Puller: 57001-1277

CAUTION

If the rotor is difficult to remove, turn the puller while tapping the end of the puller covered with the cap. Do not attempt to strike the alternator rotor itself. Striking the rotor can cause the magnets to lose their magnetism.

Alternator Rotor Installation Notes

- Clean the following portions with an oil-less cleaning fluid such as trichloroethylene or acetone.

WARNING

These cleaning fluids are usually highly flammable and harmful if breathed for prolonged periods. Be sure to heed the fluid manufacturer's warnings.

Alternator Rotor Cleaning Area

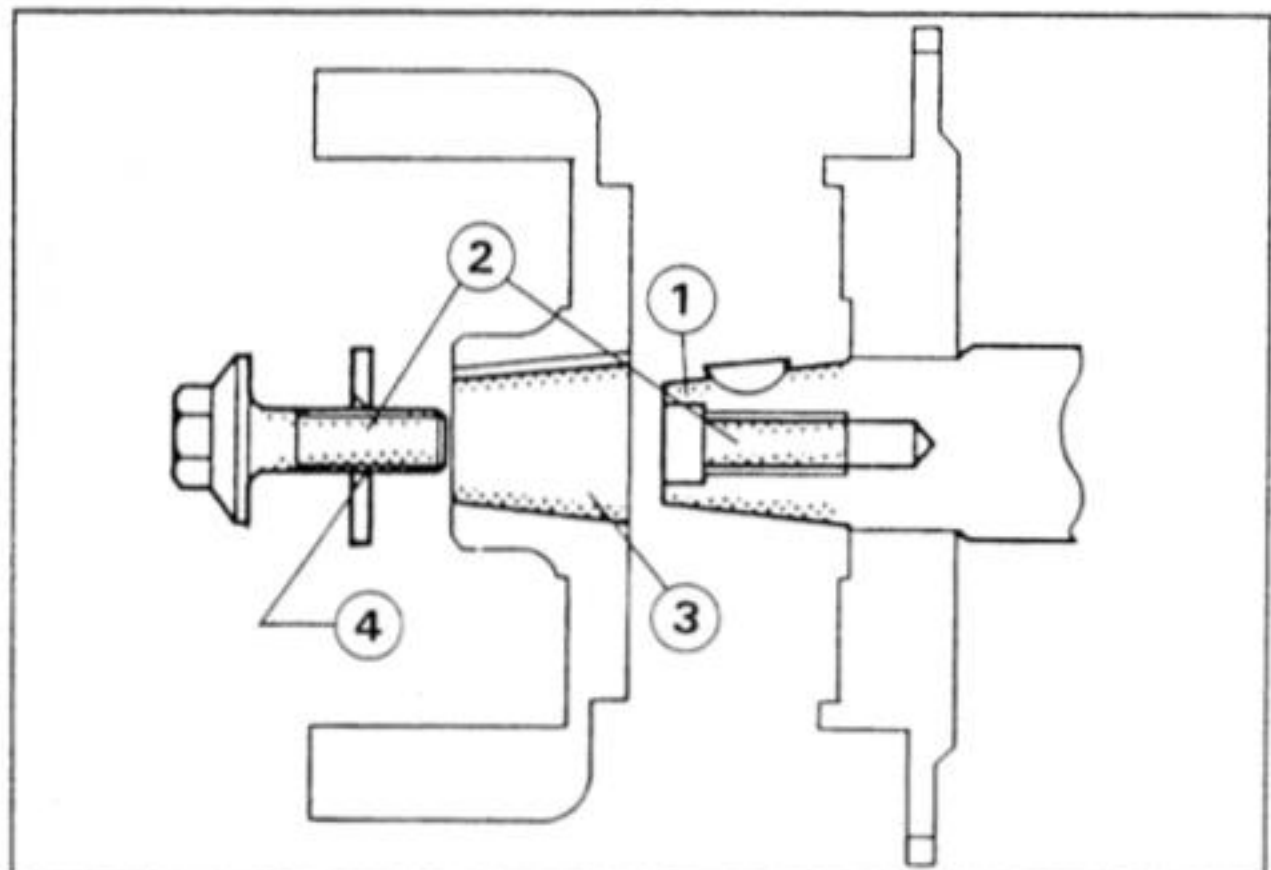

1. The tapered portion of the crankshaft.
2. The alternator rotor bolt and the threads in the crankshaft.
3. The tapered portion of the alternator rotor.
4. Chamfer

- Install the washer so that the chamfer side faces out.
- Tighten the alternator rotor bolt to the specified torque (see Exploded View) while holding the alternator rotor

15-14 ELECTRICAL SYSTEM

steady with the flywheel holder (special tool: 57001-1313).

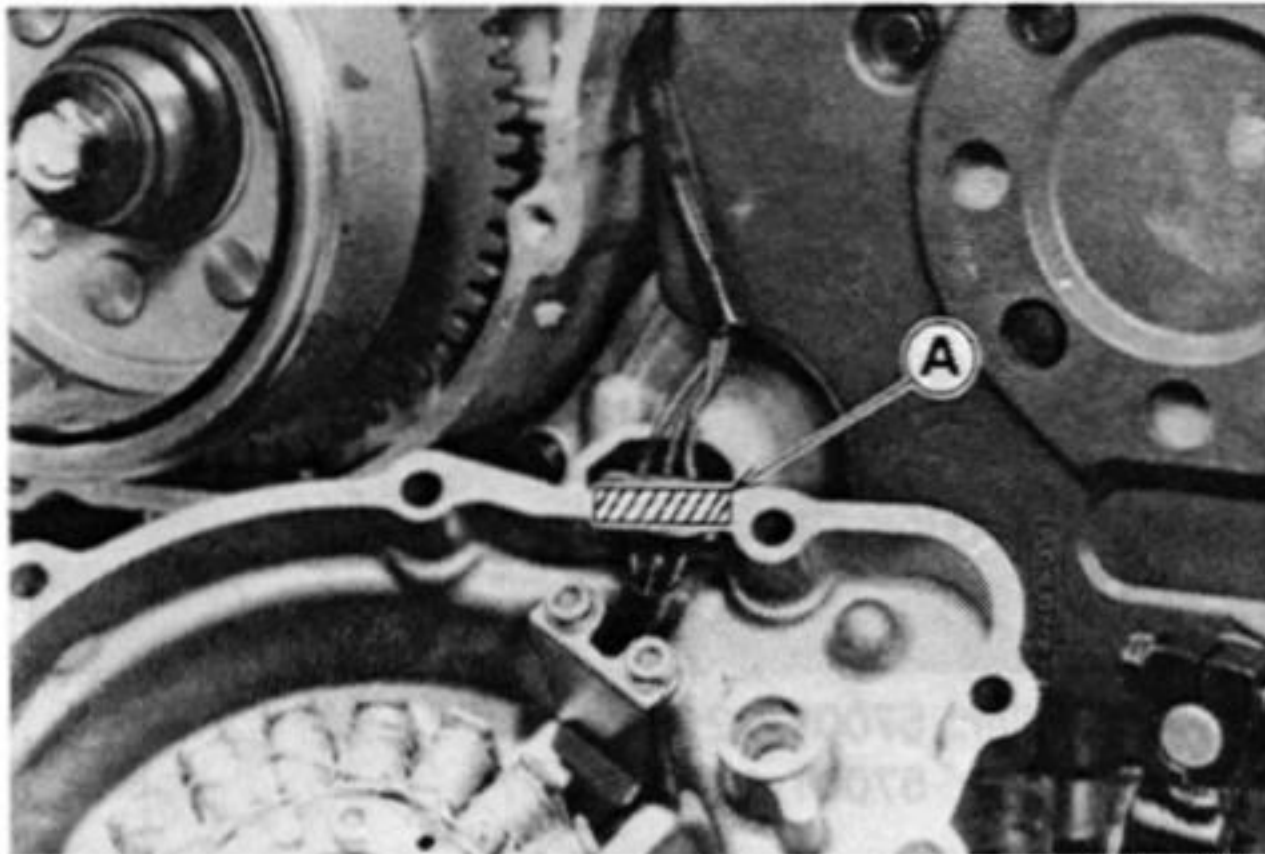

A. Silicone Sealant Applied Areas

- Install a new gasket and the alternator cover.
- Tighten the cover bolts to the specified torque (see Exploded View).
- Fill the engine with engine oil.

Stator Coil Removal

- Remove the alternator cover (see this chapter).
- Remove the holding plate.
- Remove the stator coil lead grommet out of the notch of cover.
- Unscrew the mounting bolt, and take off the stator.

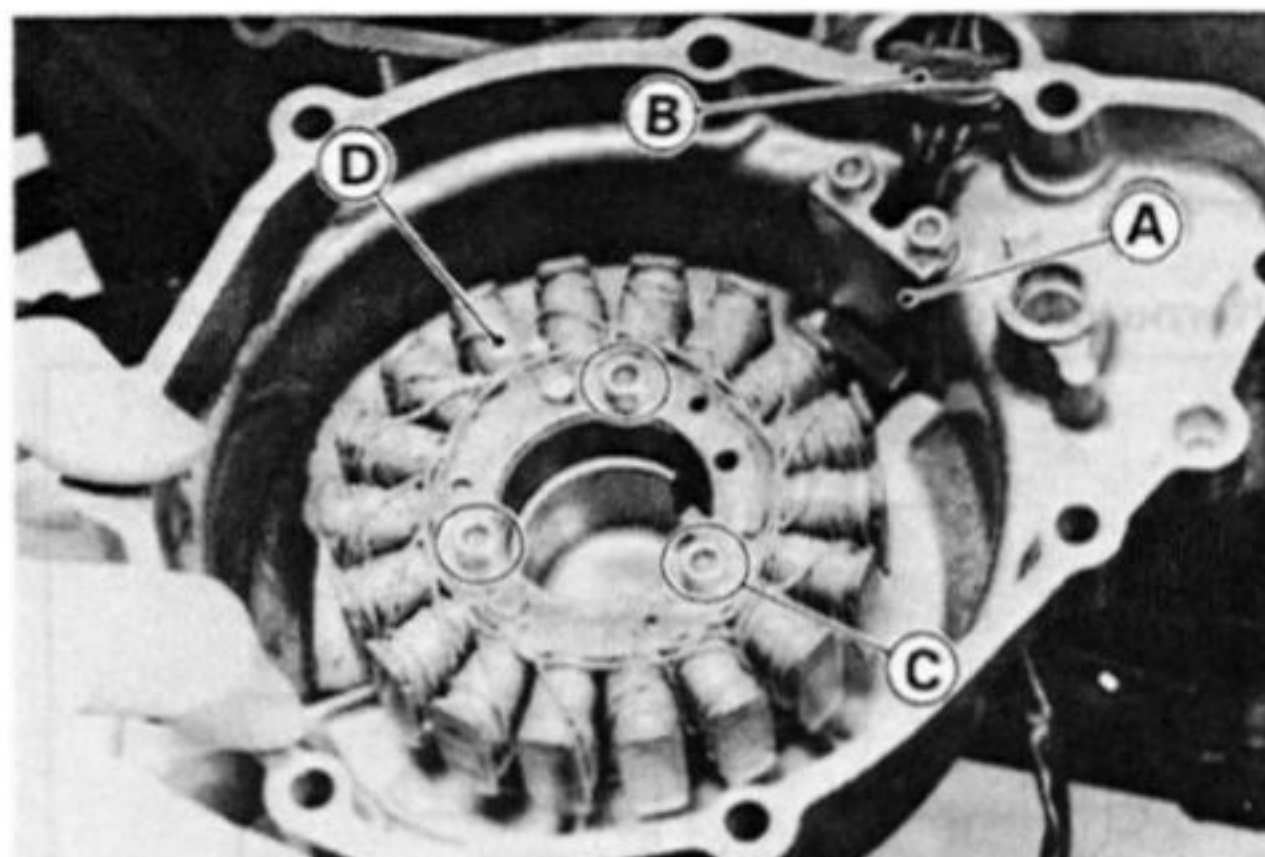

A. Holding Plate
B. Grommets
C. Mounting Bolts
D. Stator

Stator Installation Notes

- Fit the stator coil lead grommet into the notch of cover securely.
- Route the stator coil lead in accordance with the Wire Routing in the General Information chapter.

Alternator Inspection

There are three types of alternator failures: short, open (wire burned out), or loss in rotor magnetism. A short or open in one of the coil wires will result in either a low output, or no output at all. A loss in rotor magnetism, which may be caused by dropping or hitting the alternator, by leaving it near an electromagnetic field, or just by aging, will result in low output.

- To check the alternator output voltage, do the following procedures. Refer to appropriate chapters and charging system Wiring Diagram.

Turn off the ignition switch

Disconnect connector 1.

Connect the hand tester (special tool: 57001-1394) as shown in table.

Start the engine

Run it at the rpm given in table.

Note the voltage readings (total 3 measurements).

Alternator Output Voltage

Meter Range	Connections		Reading 4 000 rpm
	Meter (+) to	Meter (-) to	
250 V AC	One black lead (Connector 1)	Another black lead (Connector 1)	about 43 V

- ★ If the output voltage shows the value in table, the alternator operators properly and the regulator / rectifier is damaged. A much lower reading than that given in the table indicates that the alternator is defective.

- Check the stator coil resistance as follows:

Stop the engine

Connect the hand tester (special tool: 57001-1394) as shown in table.

Note the readings (total 3 measurement).

Stator Coil Resistance

Meter Range	Connections		Reading
	Meter (+) to	Meter (-) to	
x 1 Ω	One black lead (Connector 1)	Another black lead (Connector 1)	0.2 ~ 0.9 Ω

- ★ If there is more resistance than shown in the Table, or no meter reading (infinity) for any two leads, the stator has an open lead and must be replace. Much less than this resistance means the stator is shorted, and must be replaced.

- Using the highest resistance range of the hand tester measure the resistance between each of the yellow leads and chassis ground.

- ★ Any meter reading less than infinity (∞) indicates a short, necessitating stator replacement.

- ★ If the stator coils have normal resistance, but the voltage check showed the alternator to be defective; then the rotor magnetism have probably weakened, and the rotor must be replaced.

Rectifier Inspection

- Check the rectifier resistance as follows.
- Remove the regulator/rectifier and disconnect the connector 2 (see Charging System Wiring Diagram).
- Connect an ohmmeter to the regulator/rectifier as shown in the Table, and check the resistance in both directions of each diode following the table.

Rectifier Circuit Inspection

No.	Connections		Reading	Meter Range
	Meter (+) to	Meter (-) to		
1	Y ₁	W	∞	x 10 Ω or x 100 Ω
2	Y ₂			
3	Y ₃			
4	Y ₁	BK/Y	1/2 scale	
5	Y ₂			
6	Y ₃			
7	W	Y ₁	∞	
8		Y ₂		
9		Y ₃		
10	BK/Y	Y ₁	∞	
11		Y ₂		
12		Y ₃		

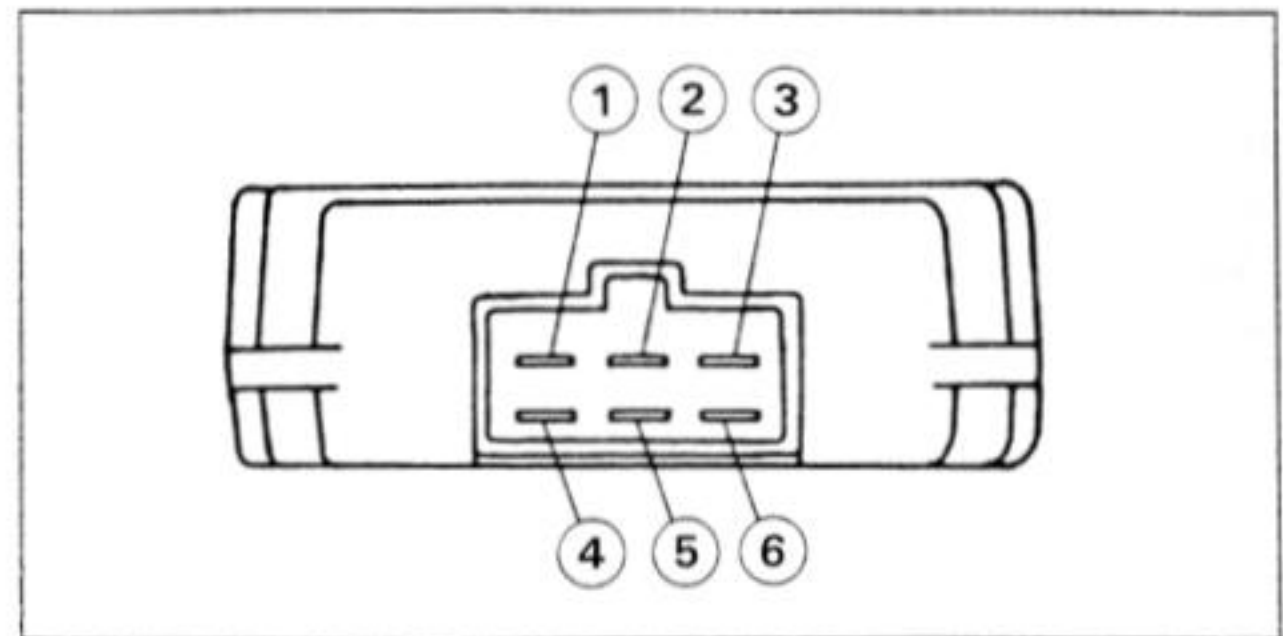

- 1. W Lead Terminal
- 2. BR Lead Terminal
- 3. BK/Y Lead Terminal
- 4. Y₁ Lead Terminal
- 5. Y₂ Lead Terminal
- 6. Y₃ Lead Terminal

NOTE

○ The actual meter reading varies with the meter used and the individual diode, but, generally speaking, the lower reading should be from zero to one half the scale.

Charging System Wiring Diagram

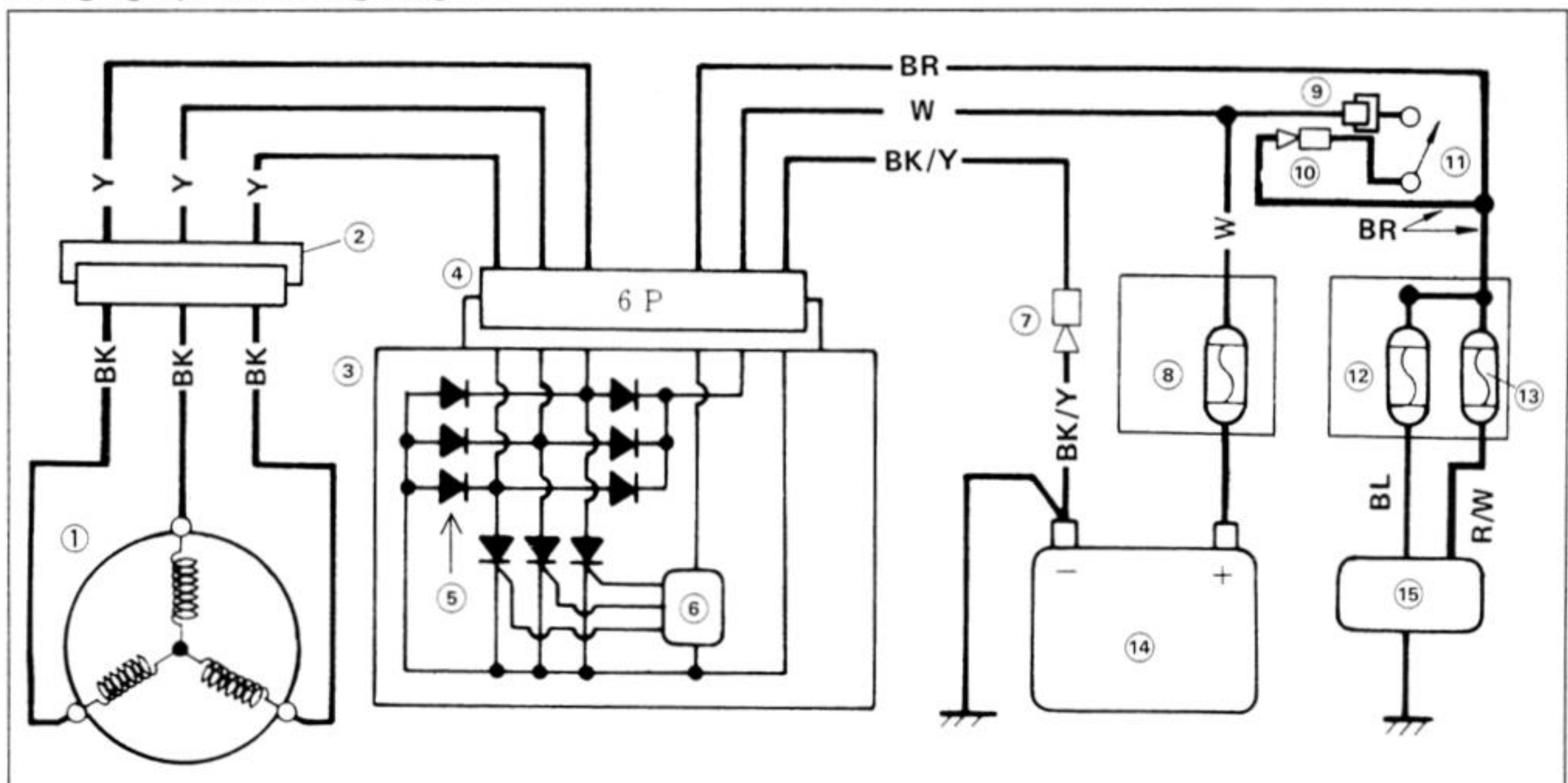

- 1. Alternator
- 2. Connector 1
- 3. Regulator/Rectifier
- 4. Connector 2
- 5. Diode (Rectifier)
- 6. Control Circuit (IC)
- 7. Connector 5
- 8. Main Fuse 30A
- 9. Connector 3
- 10. Connector 4
- 11. Ignition Switch
- 12. Headlight 10A Fuse (Junction Box)
- 13. Taillight 10A Fuse (Junction Box)
- 14. Battery
- 15. Load

15-16 ELECTRICAL SYSTEM

Regulator Inspection

To test the regulator out of circuit, use three 12 V batteries and a test light made from 12 V 3 ~ 6 W bulb in a socket with leads.

- Remove the regulator/rectifier unit from the frame.
- Using auxiliary leads, connect one of the yellow lead terminal at the unit to the battery (+) terminal, and connect the test light between the black/yellow lead terminal at the unit, and the battery (-) terminal.
- At this time the bulb should not be lit.

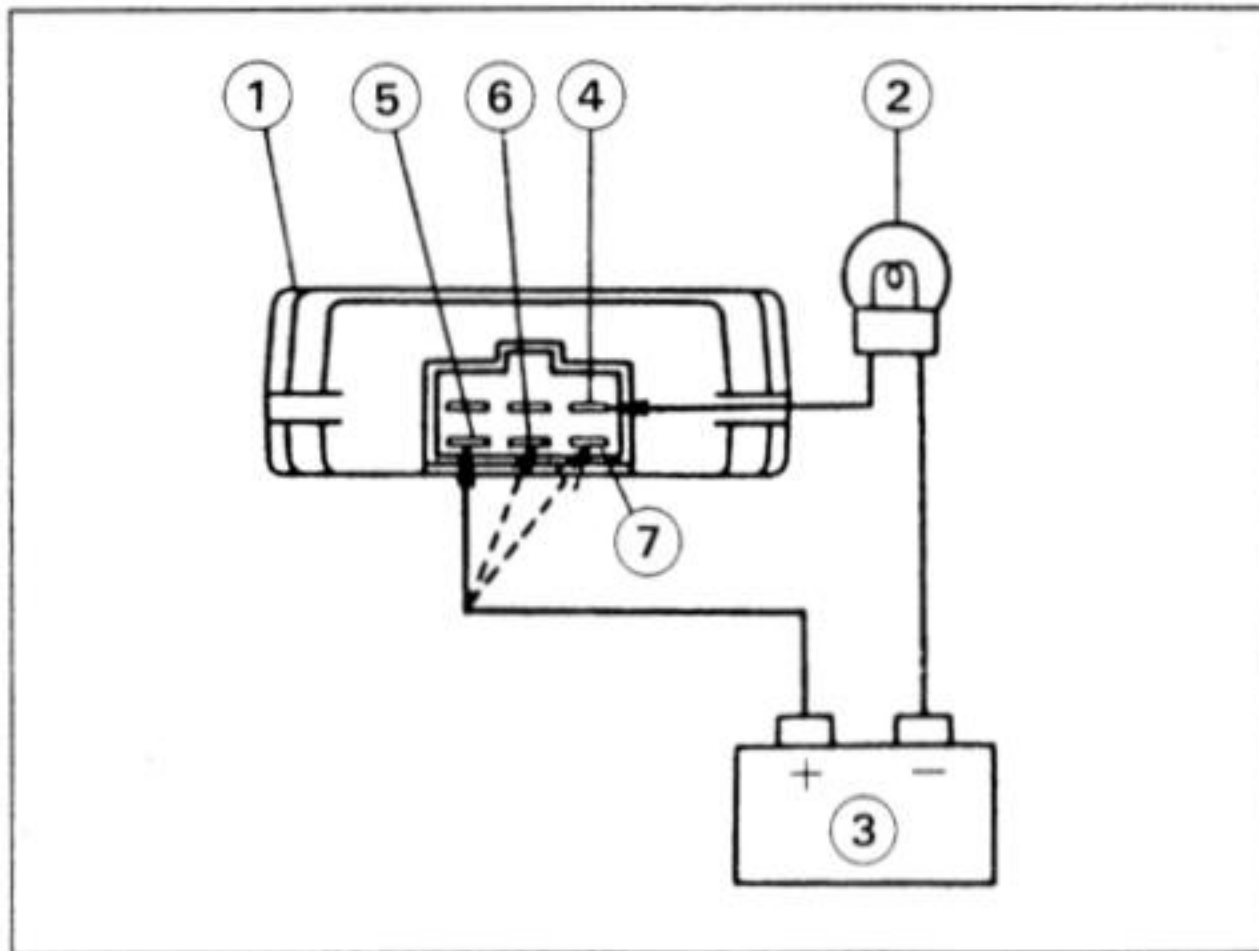

- | | |
|------------------------|---------------------|
| 1. Regulator/Rectifier | 5. Y1 Lead Terminal |
| 2. Test Light | 6. Y2 Lead Terminal |
| 3. 12 V Battery | 7. Y3 Lead Terminal |
| 4. BK/Y Lead Terminal | |

CAUTION

The test light works as an indicator and also as a current limiter to protect the regulator/rectifier from excessive current. Do not use an ammeter instead of a test light.

- Connect the brown lead terminal to the other battery (+) terminal and connect the black/yellow lead terminal to the battery (-) terminal momentarily. At this time the bulb should not be lit.

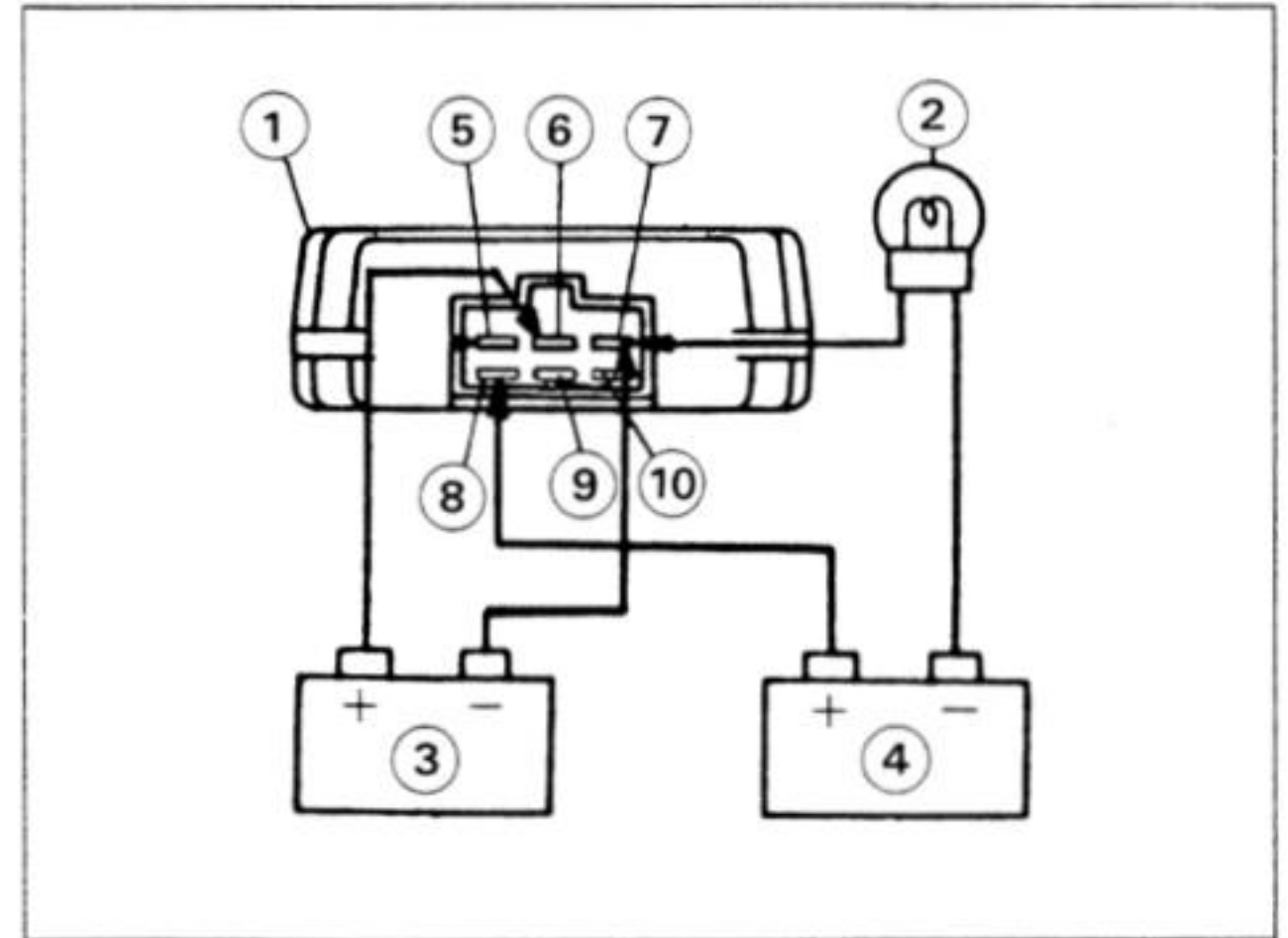

- | | |
|------------------------|-----------------------|
| 1. Regulator/Rectifier | 6. BR Lead Terminal |
| 2. Test Light | 7. BK/Y Lead Terminal |
| 3. 12 V Battery | 8. Y1 Lead Terminal |
| 4. 12 V Battery | 9. Y2 Lead Terminal |
| 5. W Lead Terminal | 10. Y3 Lead Terminal |

- To apply 24 V to the regulator/rectifier, connect two 12 V batteries in series, and connect the brown lead terminal to the battery (+) terminal and the black/yellow lead terminal to the battery (-) terminal momentarily. The bulb should now light and stay on until the bulb circuit is opened.

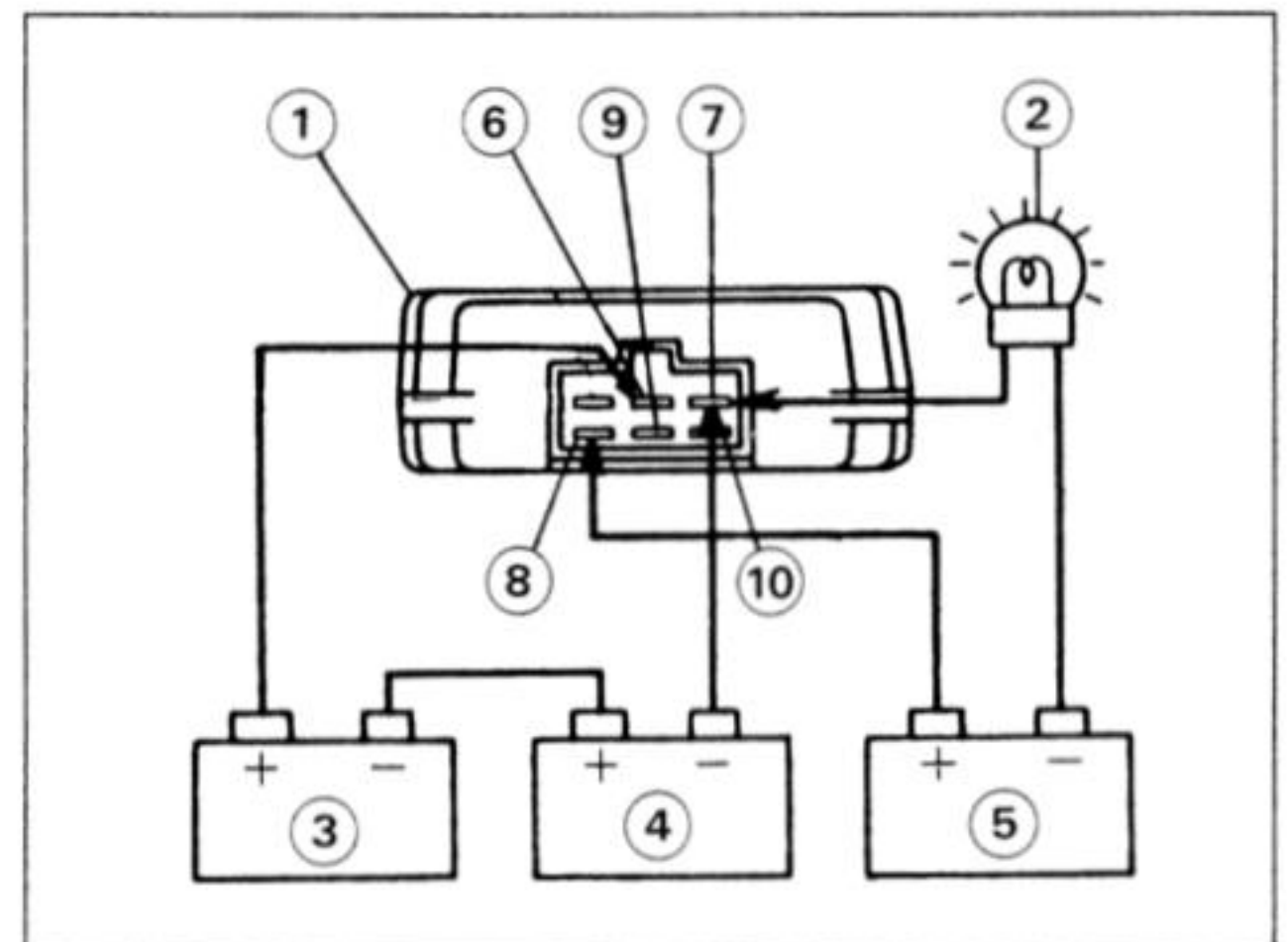

- | | |
|------------------------|-----------------------|
| 1. Regulator/Rectifier | 6. BR Lead Terminal |
| 2. Test Light | 7. BK/Y Lead Terminal |
| 3. 12 V Battery | 8. Y1 Lead Terminal |
| 4. 12 V Battery | 9. Y2 Lead Terminal |
| 5. 12 V Battery | 10. Y3 Lead Terminal |

CAUTION

Do not apply more than 24 volts. If more than 24 volts is applied, the regulator/rectifier may be damaged. Do not apply 24 V more than a few seconds. If 24 volts is applied for more than a few seconds, the regulator/rectifier may be damaged.

- Repeat the above three steps for other two yellow leads (in connector 2 which leads to the regulator/rectifier).

- ★ Replace the regulator/rectifier if the bulb does not light as described above.

NOTE

○ *The above test is not foolproof. If the above checks show the regulator/rectifier is not damaged, but there is still trouble in the charging system, first carefully inspect the alternator, battery, wiring, and all connections. Replace the regulator/rectifier if all these other components turn out good.*

Regulator/Rectifier Output Voltage Inspection

- Check the battery condition (see Battery section).
- Warm up the engine to obtain actual alternator operating conditions.
- Remove the seat.
- Check that the ignition switch is turned off, and connect the hand tester as shown in table.

Regulator/Rectifier Output/Voltage

Meter Range	Connections		Reading
	Meter (+) to	Meter (-) to	
25 V DC	Battery (+)	Black/Yellow (Connector 5)	Battery Voltage – 14 ~ 15 V

- Start the engine, and note the voltage readings at various engine speeds with the headlight turned on and then turned off. The readings should show nearly battery voltage when the engine speed is low, and, as the engine speed rises, the readings should also rise. But they must be kept under the specified voltage.
- Turn off the ignition switch to stop the engine, and disconnect the hand tester.
- ★ If the regulator/rectifier output voltage is kept between the values given in table, the charging system is considered to be working normally.
- ★ If the output voltage is much higher than the values specified in the table, the regulator/rectifier is defective or the regulator/rectifier leads are loose or open.
- ★ If the battery voltage does not rise as the engine speed increases, then the regulator/rectifier is defective or the alternator output is insufficient for the loads. Check the alternator and regulator/rectifier to determine which part is defective.

Ignition System

⚠ WARNING

The ignition system produces extremely high voltage. Do not touch the spark plugs, ignition coils, or spark plug leads while the engine is running, or you could receive a severe electrical shock.

CAUTION

Do not disconnect the battery leads or any other electrical connections when the ignition switch is on, or while the engine is running. This is to prevent IC igniter damage. Do not install the battery backwards. The negative side is grounded. This is to prevent damage to the diodes and IC igniter.

Pickup Coil Removal

- Remove the pickup coil cover.
- Remove the pickup coil.

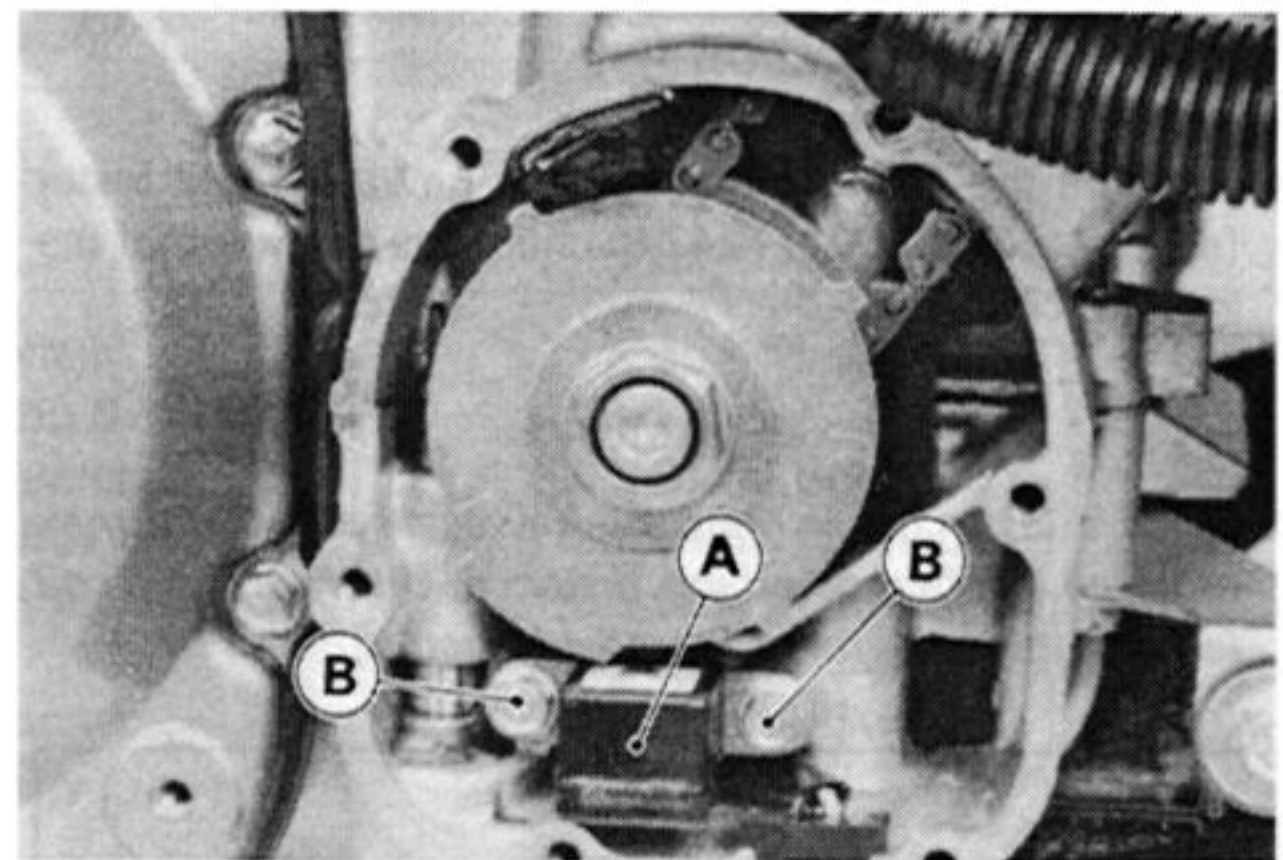

A. Pickup Coil B. Mounting Bolts

Pickup Coil Installation

- Tighten the pickup coil mounting bolt to the specified torque (see Exploded View).
- Install the pickup coil cover.

Pickup Coil Inspection

- Disconnect the pickup coil connector.
- Zero an ohmmeter, and connect it to the pickup coil leads.
- ★ If there is more resistance than the specified value, the coil has an open lead and must be replaced. Much less than this resistance means the coil is shorted, and must be replaced.

15-18 ELECTRICAL SYSTEM

Pickup Coil Resistance (x 100 Ω)

355 ~ 535 Ω (BK, Y Lead)

- Using the highest resistance range of the ohmmeter, measure the resistance between the pickup coil leads and chassis ground.
- ★ Any meter reading less than infinity (∞) indicates a short, necessitating replacement of the pickup coil assembly.

Ignition Coil Removal

- Remove the air cleaner housing.
- Remove the ignition coil from the bracket.

Ignition Coil Installation

- Connect the primary leads to the ignition coil terminals.
 - Black Lead → to #1, #4 Coil
 - Green Lead → to #2, #3 Coil
 - Red Lead → to both Coils

Ignition Coil Inspection

- Remove the ignition coils.
- Measure the arcing distance with Kawasaki coil tester (special tool: 57001-1242 to check the condition of the ignition coil.

NOTE

- Since a tester other than the Kawasaki coil tester may produce a different arcing distance, the Kawasaki coil tester is recommended for reliable results.

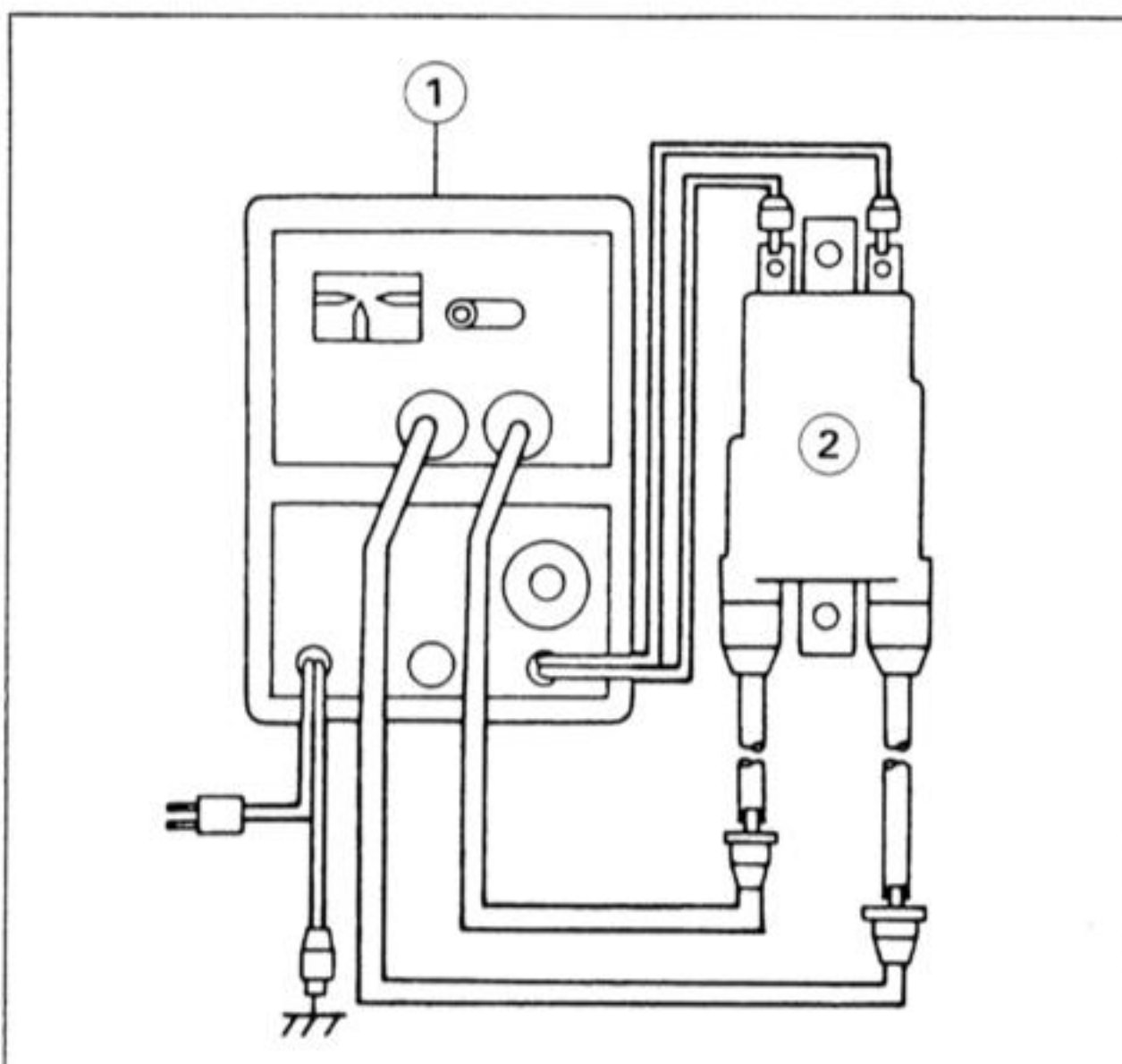

1. Ignition Coil Tester: 57001-1242
2. Ignition Coil

⚠ WARNING

To avoid extremely high voltage shocks, do not touch the coil or lead.

- ★ If the distance reading is less than the specified value, the ignition coil or spark plug caps are defective.

Ignition Coil Arcing Distance

7 mm or more

- To determine which part is defective, measure the arcing distance again with the spark plug caps removed from the ignition coil.
- ★ If the arcing distance is subnormal as before, the trouble is with the ignition coil itself. If the arcing distance is now normal, the trouble is with the spark plug caps.

Measuring coil resistance:

If the arcing tester is not available, the coil can be checked for a broken or badly shorted winding with an ohmmeter. However, an ohmmeter cannot detect layer shorts and shorts resulting from insulation breakdown under high voltage.

- Disconnect the primary leads from the coil terminals.
- Measure the primary winding resistance.
 - Connect an ohmmeter between the coil terminals.
 - Set the meter to the x 1 Ω range, and read the meter.
- Measure the secondary winding resistance.
 - Pull the spark plug cap off the lead.
 - Connect an ohmmeter between the spark plug leads.
 - Set the meter to the x 1 k Ω , and read the meter.
- ★ If the meter does not read as specified, replace the coil.

Ignition Coil Winding Resistance

Primary Windings: 2.3 ~ 3.5 Ω
Secondary Windings: 12 ~ 18 k Ω

Ignition Coil Winding Resistance

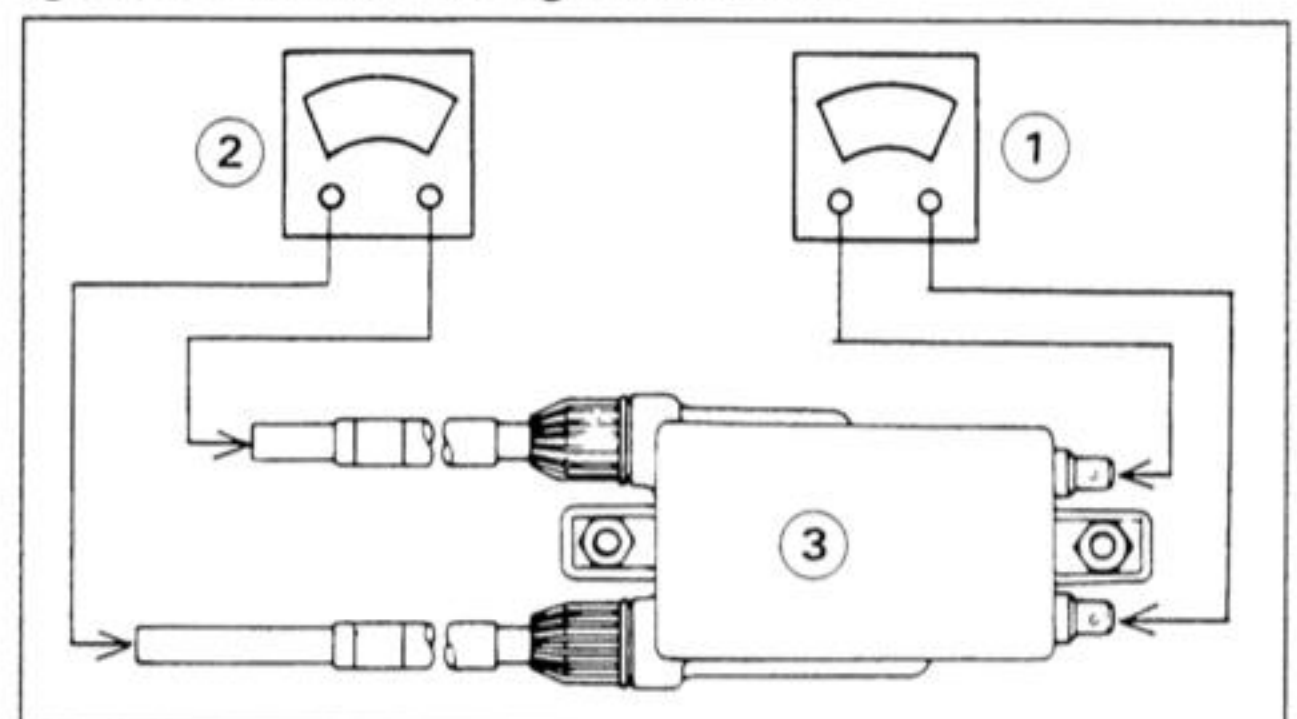

1. Measure primary winding resistance.
2. Measure secondary winding resistance.
3. Ignition Coil

- ★ If the meter reads as specified, the ignition coil windings are probably good. However, if the ignition system still does not perform as it should after all other components have been checked, test replace the coil with one known to be good.

- Check the spark plug leads for visible damage.
- ★ If any spark plug lead is damaged, replace the coil.

Ignition System Wiring Diagram

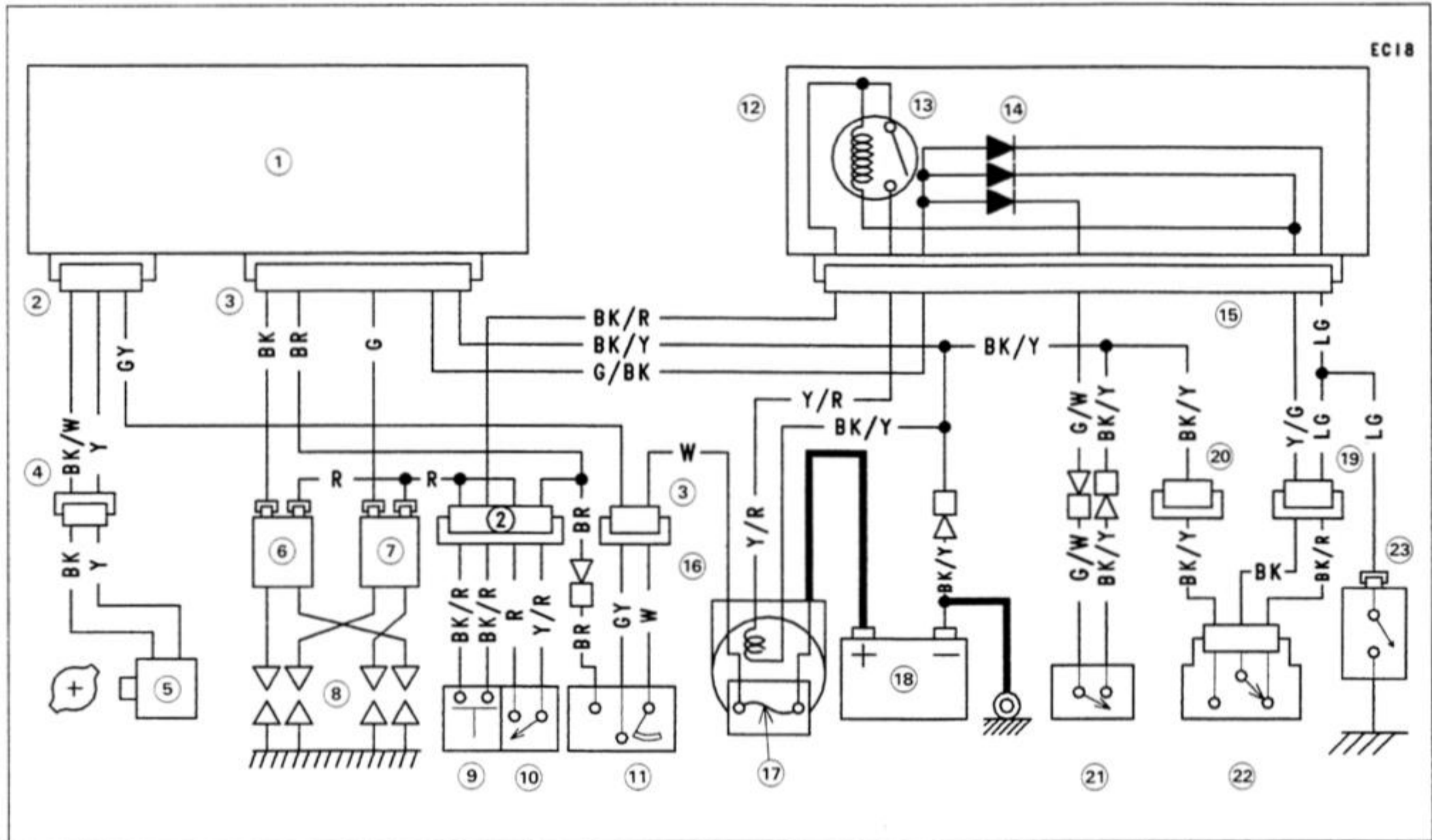

- | | | |
|--|---------------------------|----------------------------|
| 1. IC Igniter | 9. Starter Switch | 17. 30A Main Fuse |
| 2. 4-Pin Connector | 10. Engine Stop Switch | 18. Battery |
| 3. 6-Pin Connector | 11. Ignition Switch | 19. 2-Pin Connector |
| 4. 2-Pin Connector | 12. Junction Box | 20. 9-Pin Connector |
| 5. Pickup Coil | 13. Starter Circuit Relay | 21. Side Stand Switch |
| 6. Ignition Coil (for #1, #4 Cylinder) | 14. Diodes | 22. Starter Lockout Switch |
| 7. Ignition Coil (for #2, #3 Cylinder) | 15. 10-Pin Connector | 23. Neutral Switch |
| 8. Spark Plugs | 16. Starter Relay | |

Spark Plug Removal

- Remove the following.
 - Air Cleaner Housing
 - Spark Plug Caps
- Remove the spark plugs with the box wrench in the tool kit (P/N: 92110-1146) or the spark plug wrench (special tool: 57001-1262).

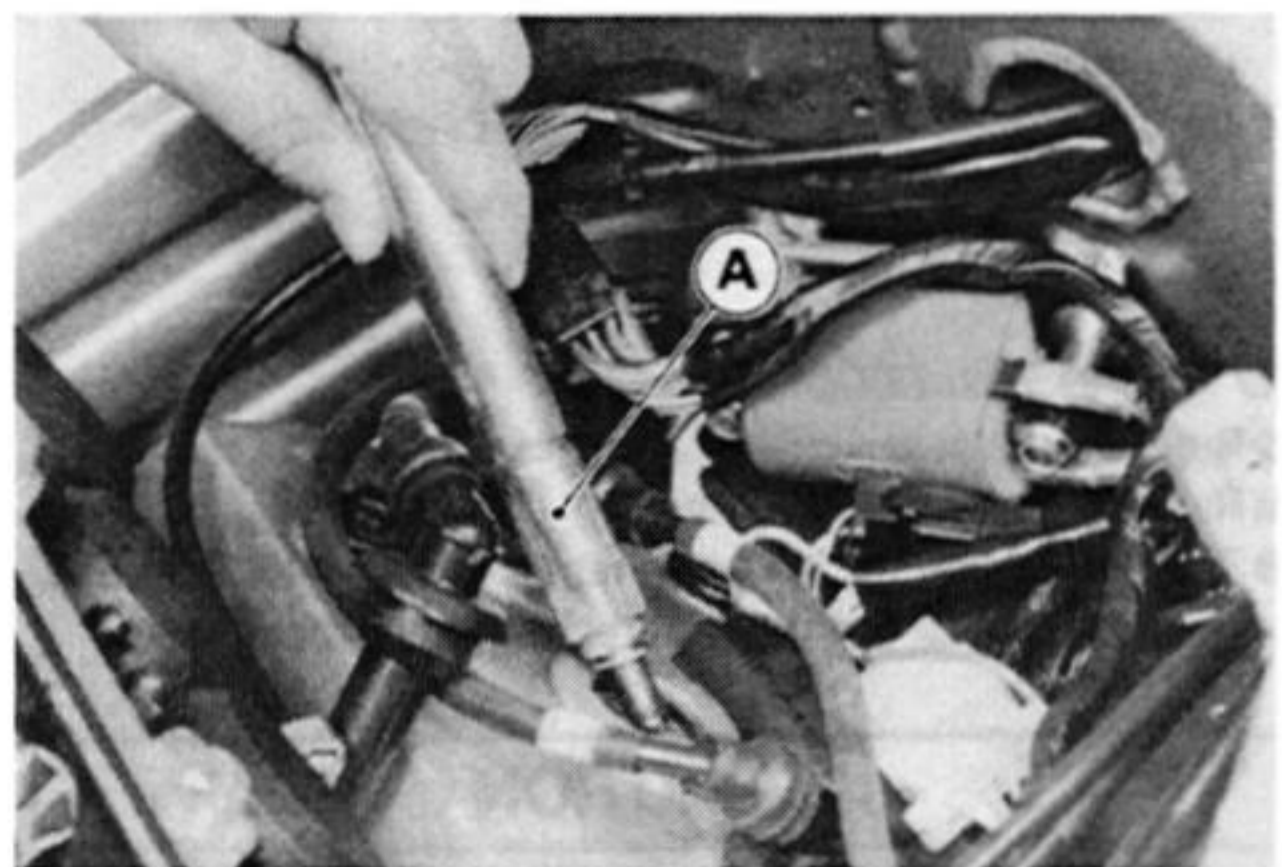

A. Spark Plug Wrench: 92110-1146

15-20 ELECTRICAL SYSTEM

Spark Plug Installation Note

- Tighten the spark plugs to the specified torque (see Exploded View).
- Run the spark plug leads correctly (see Cable Routing section in the General Information chapter).

Spark Plug Cleaning and Inspection

- Remove the spark plug, and visually inspect.
- Clean the spark plug, preferably in a sandblasting device, and then clean off any abrasive particles. The plug may also be cleaned using a high flash point solvent and a wire brush or other suitable tool.
- ★ If the spark plug electrodes are corroded or damaged, or if the insulator is cracked, replace the plug. Use the standard spark plug or its equivalent.

Spark Plug Gap Inspection

- Measure the gap with a wire-type thickness gauge.
- ★ If the gap is incorrect, carefully bend the side electrode with a suitable tool to obtain the correct gap.

Spark Plug Gap

0.7 ~ 0.8 mm

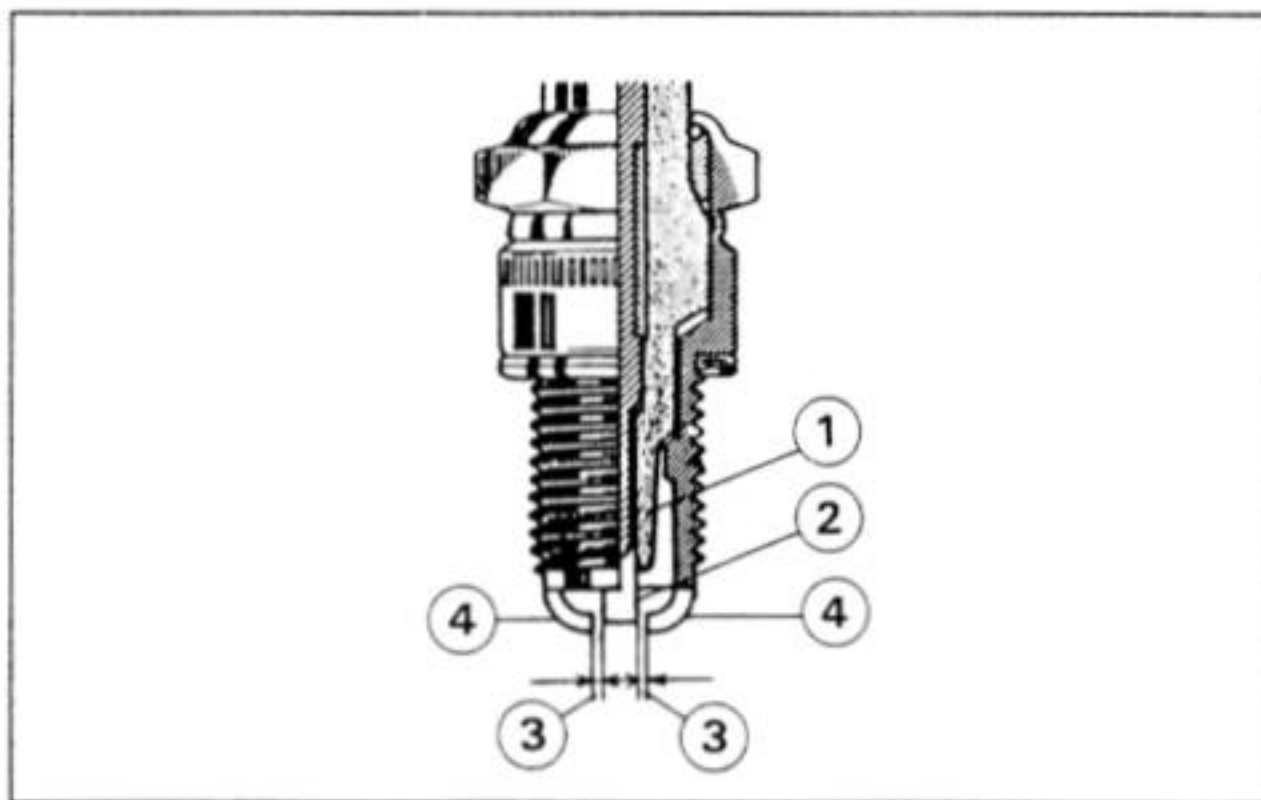

- | | |
|---------------------|-------------------|
| 1. Insulator | 3. Plug Gap |
| 2. Center Electrode | 4. Side Electrode |

IC Igniter Inspection

- Remove the seat.
- Remove the igniter connector.
- Zero an ohmmeter, and connect it to terminals of the IC igniter to check the internal resistance of the igniter.

CAUTION

Use only Hand Tester 57001-983 for this test. A tester other than the Kawasaki Hand Tester may show different readings.
If a megger or a meter with a large-capacity battery is used, the IC igniter will be damaged.

- ★ Replace the IC igniter if the reading is not the specified value.

IC Igniter Internal Resistance

Range : kΩ

Tester (-) Lead Con- nection	Tester Positive (+) Lead Connection								
	A	B	C	D	E	F	G	H	I
A	-	2.5	4.4	2.4	6.5	6.5	7.2	10.5	2.7
	~	~	~	~	~	~	~	~	~
B	39	-	1.1	0	1.6	1.6	2.9	4	0.22
	~	~	~	~	~	~	~	~	~
C	40	1.1	-	1.1	3.5	3.5	4.3	5.9	1.3
	~	~	~	~	~	~	~	~	~
D	39	0	1.1	-	1.7	1.6	2.9	3.9	0.2
	~	~	~	~	~	~	~	~	~
E	∞	∞	∞	∞	-	∞	∞	∞	∞
	~	~	~	~	~	~	~	~	~
F	∞	∞	∞	∞	∞	-	∞	∞	∞
	~	~	~	~	~	~	~	~	~
G	43	3.3	4.9	3.3	6.5	6.5	-	3.3	4.6
	~	~	~	~	~	~	~	~	~
H	50	6.1	8	6.1	12	12	7	-	6.4
	~	~	~	~	~	~	~	~	~
I	40	0.15	1.3	0.15	1.9	1.9	3.2	4.2	-
	~	~	~	~	~	~	~	~	~

IC Igniter Terminal

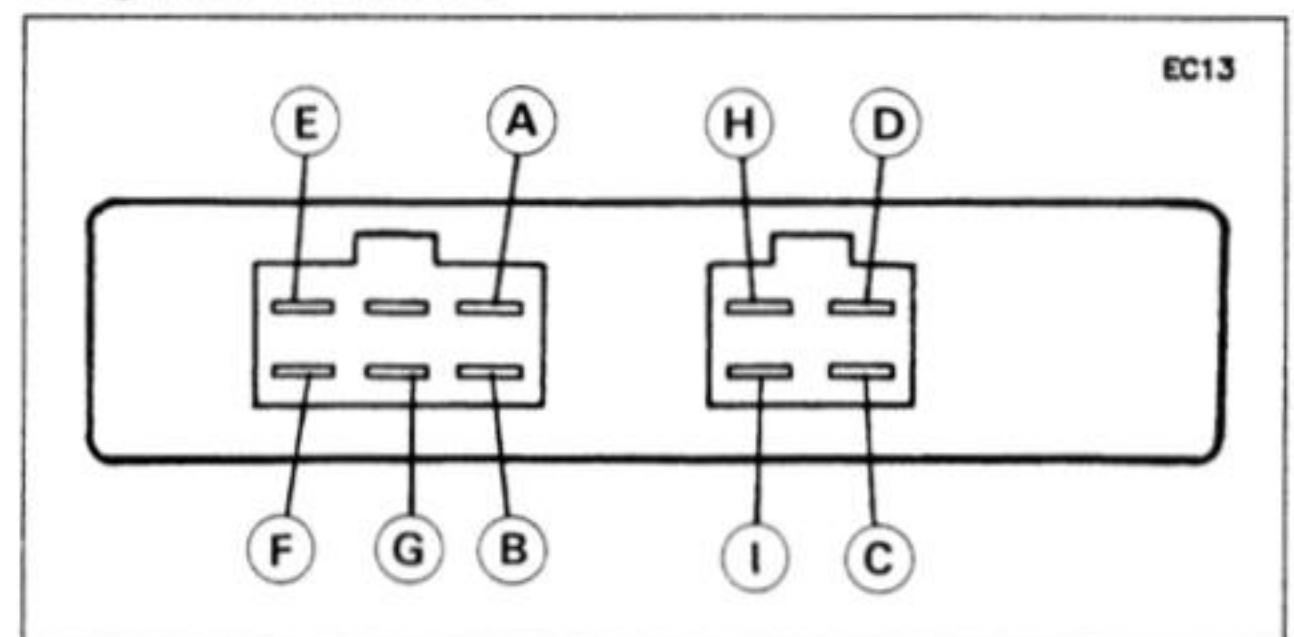

NOTE

- No measurement is needed on H terminal.

Electric Starter System

Starter Motor Removal

- Remove the fuel tank.
- Remove the terminal nut of starter motor wiring and take out the mounting bolts.
- Using the socket wrench (special tool: 57001-1268) makes work easy.
- Pull the starter motor upwards with twisting motion.

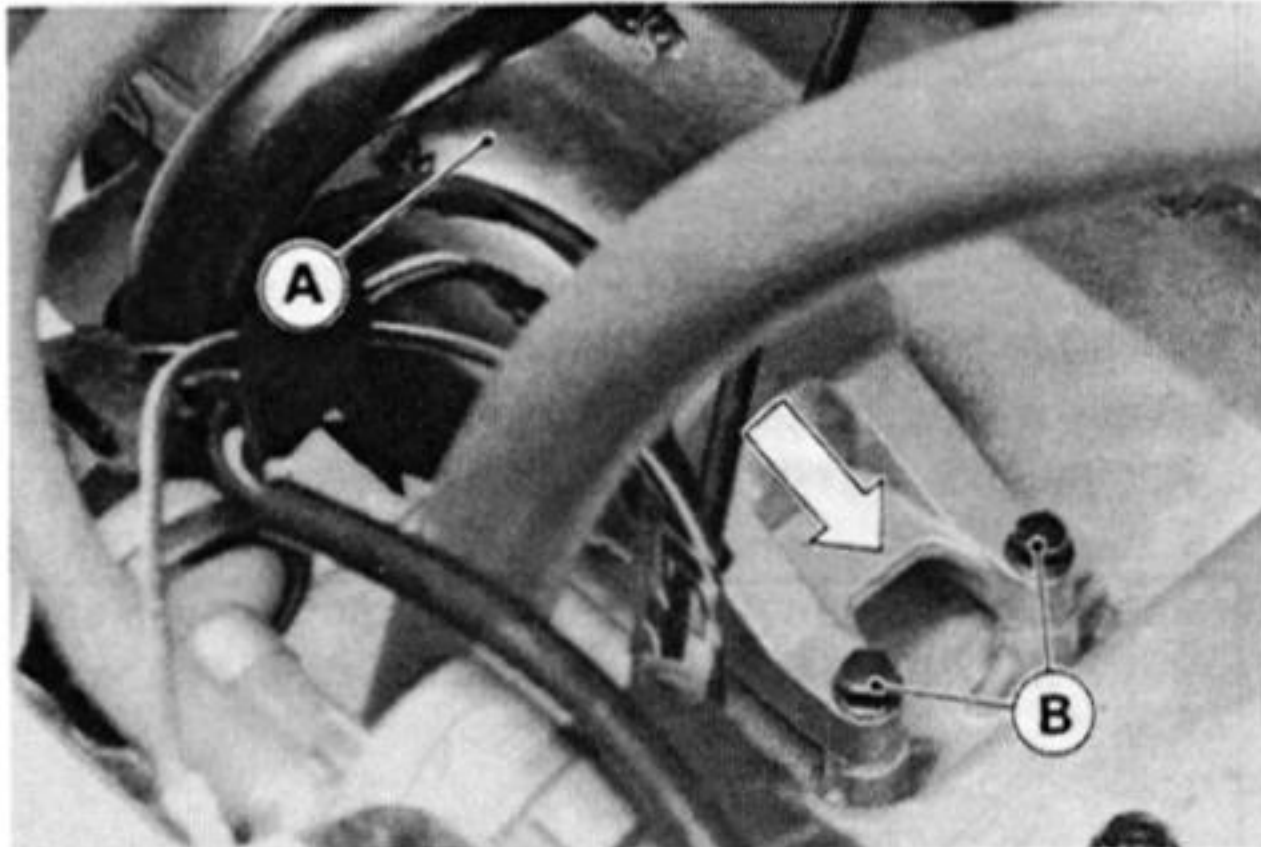

A. Starter Motor

B. Mounting Bolts

Starter Motor Installation

CAUTION

Do not tap the starter motor shaft or body. Tapping the shaft or body could damage the motor.

- When installing the starter motor, clean the starter motor legs and crankcase where the starter motor is grounded.
- Apply a small amount of engine oil to the O-ring.
- Tighten the following fasteners to the specified torque (see Exploded View).
Starter Motor Mounting Bolts

Starter Motor Disassembly

- Remove both end covers and pull the armature out of yoke.

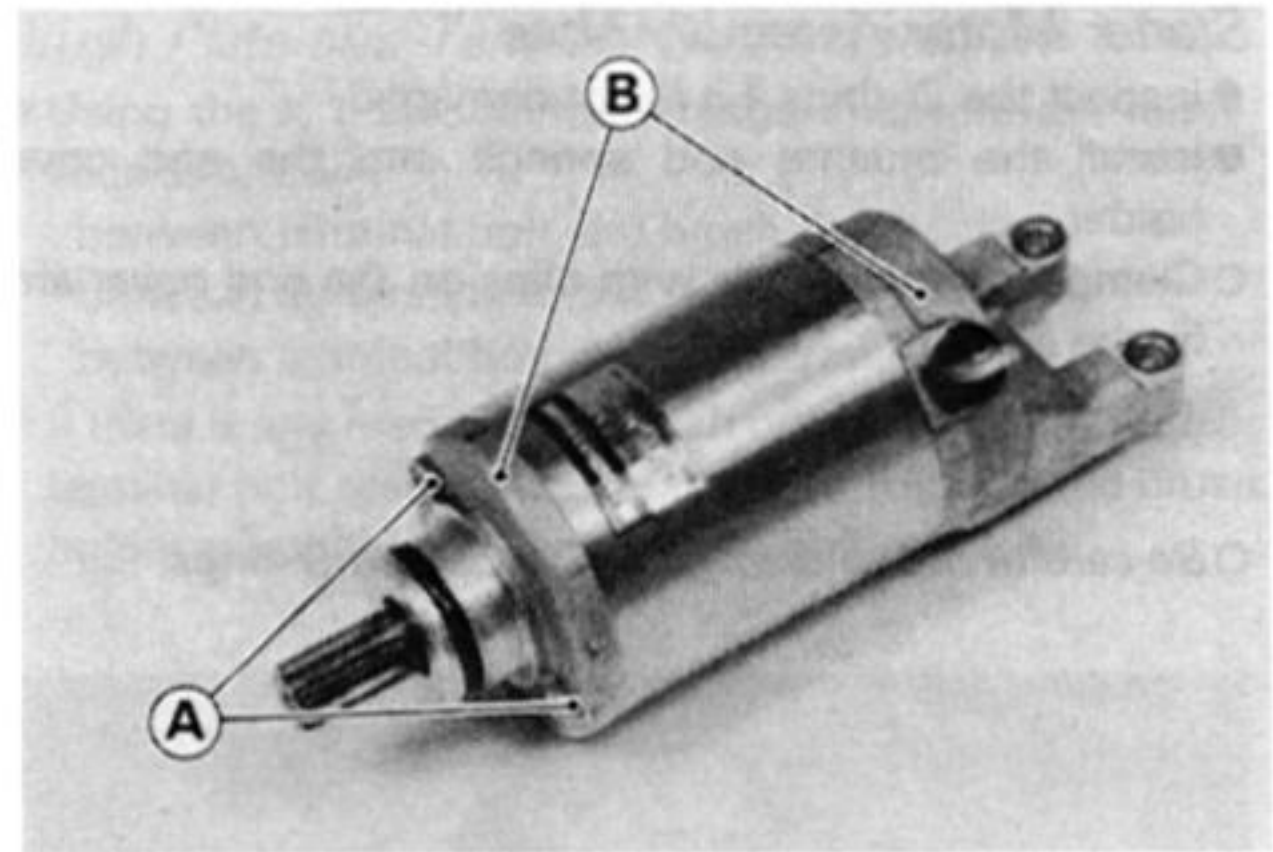

A. Bolts

B. End Covers

- Be careful not to lose the brush springs.
- Remove the screw and take out the (-) brushes.
- Unsolder the (+) terminal and take out the (+) brushes.

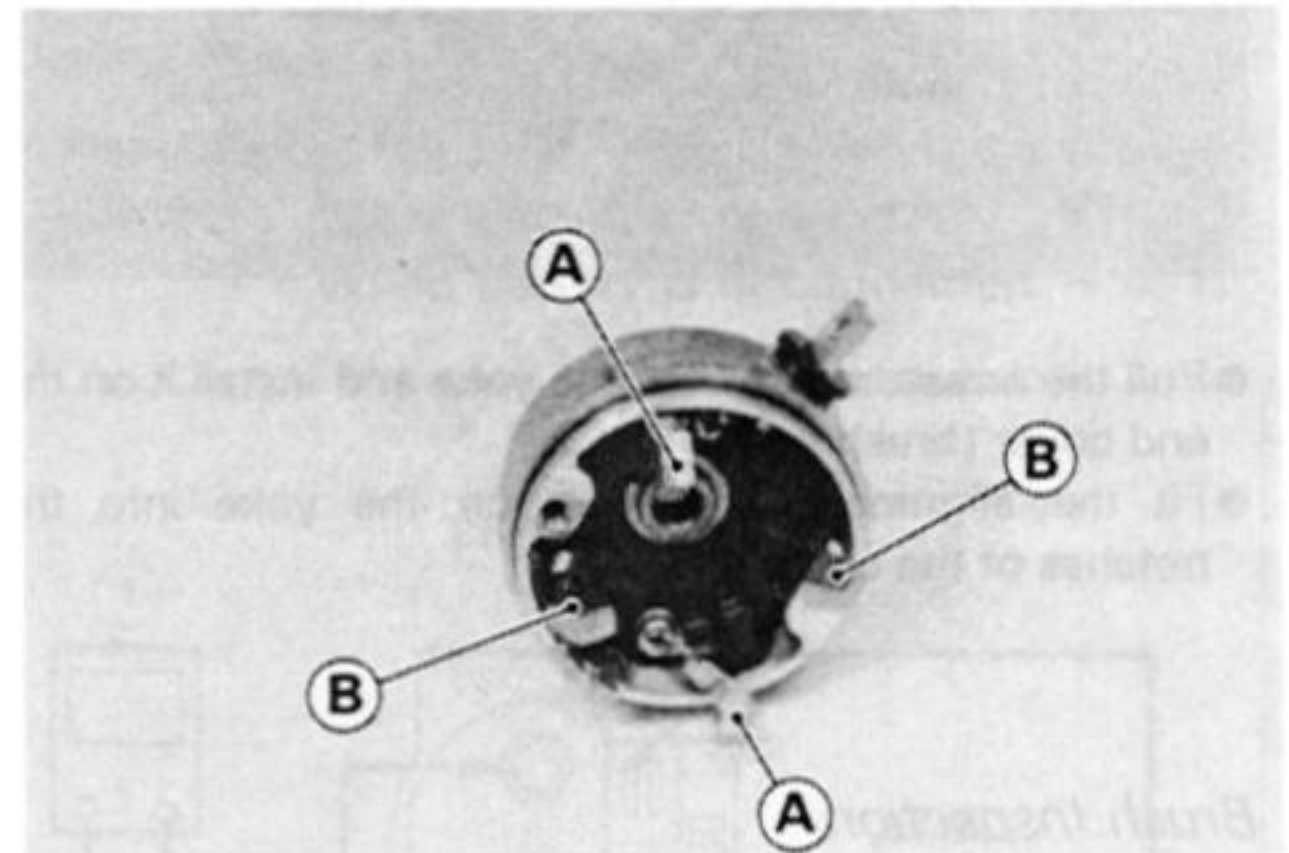

A. (-) Brushes

B. (+) Brushes

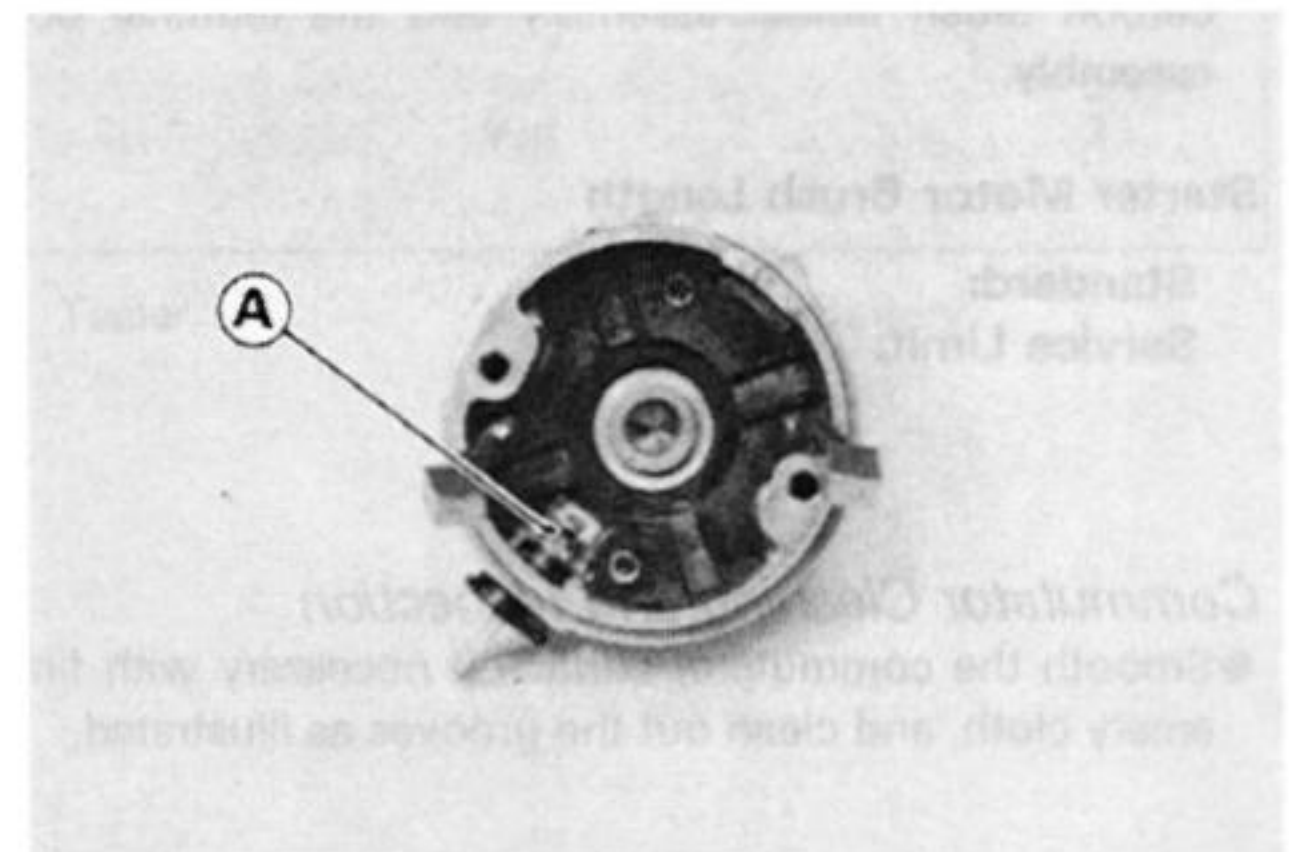

A. Soldered Terminal

15-22 ELECTRICAL SYSTEM

Starter Motor Assembly Note

- Inspect the O-rings if it is not damaged.
- Install the brushes and springs into the end cover holder.
- Clamp the brush leads with clips on the end cover and fix the springs.

NOTE

- Be careful not to damage the leads and O-rings.

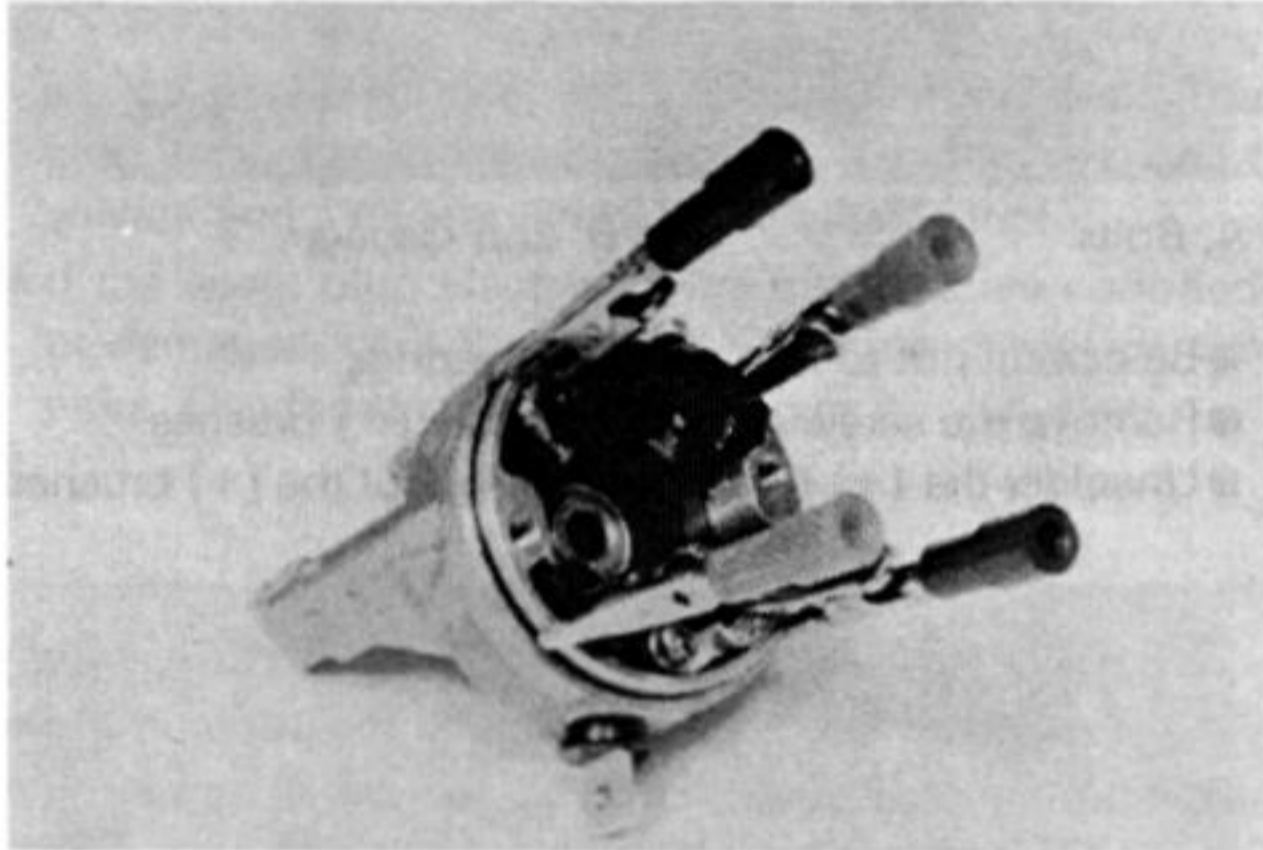

- Pull the armature out from the yoke and install it on the end cover (brush side).
- Fit the alignment projection on the yoke into the notches of the end cover.

Brush Inspection

- Measure the length of each brush.
- ★ If any is worn down to the service limit, replace the carbon brush holder assembly and the terminal bolt assembly.

Starter Motor Brush Length

Standard:	7.0 mm
Service Limit:	3.5 mm

Commutator Cleaning and Inspection

- Smooth the commutator surface if necessary with fine emery cloth, and clean out the grooves as illustrated.

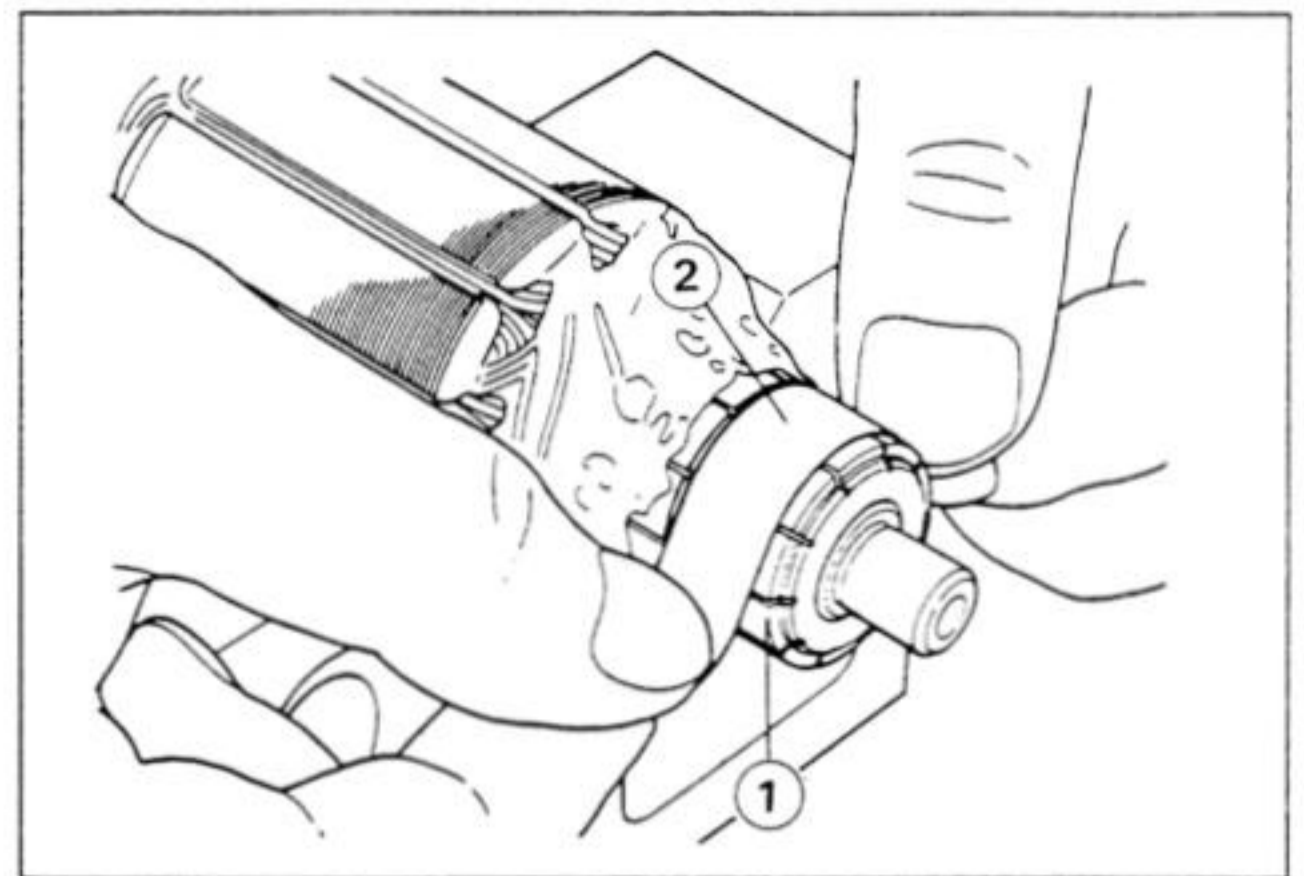

1. Commutator 2. Emery Cloth

- Measure the diameter of the commutator.
- ★ Replace the starter motor with a new one if the commutator diameter is less than the service limit.

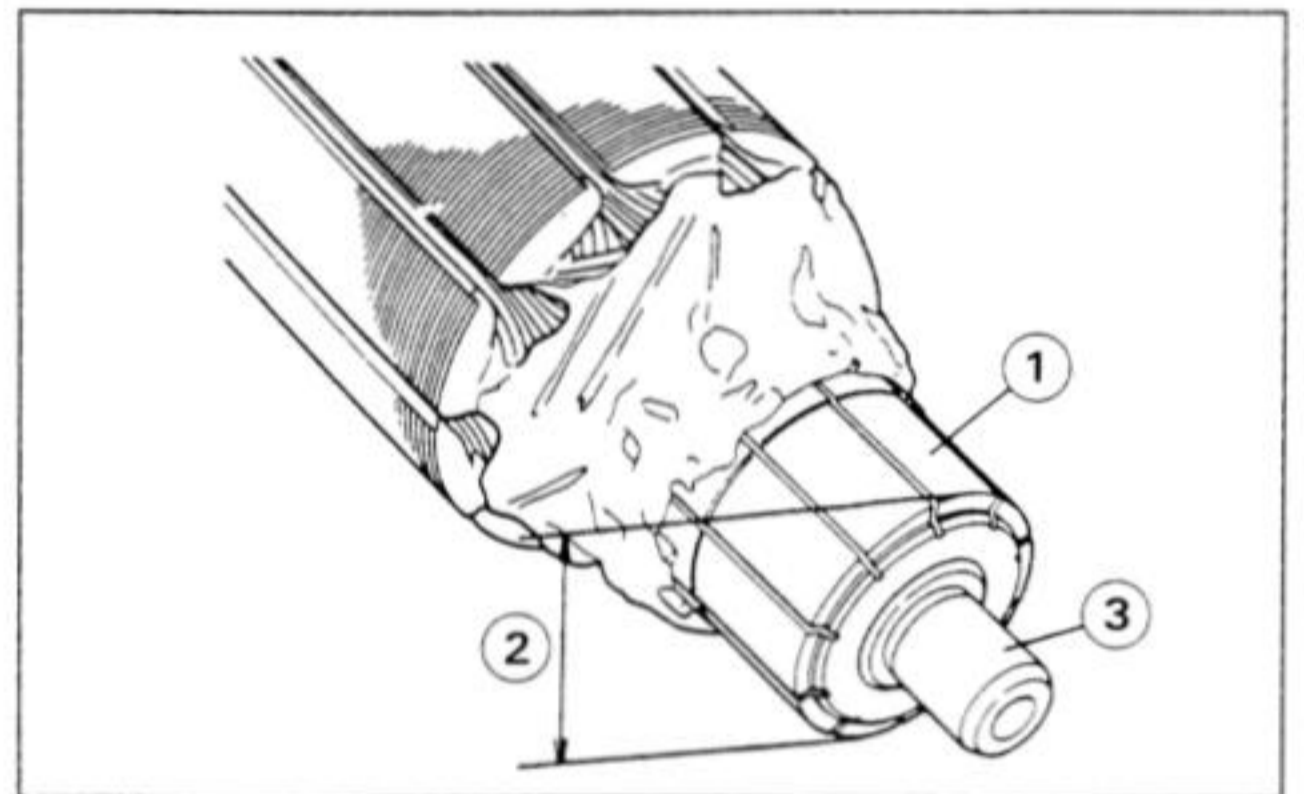

1. Commutator Segment 3. Shaft
2. Diameter

Commutator Diameter

Standard:	24 mm
Service Limit:	23 mm

Armature Inspection

- Using the x 1 Ω ohmmeter range, measure the resistance between any two commutator segments.
- ★ If there is a high resistance or no reading (∞) between any two segments, a winding is open and the starter motor must be replaced.
- Using the highest ohmmeter range, measure the resistance between the segments and the shaft.
- ★ If there is any reading at all, the armature has a short and the starter motor must be replaced.

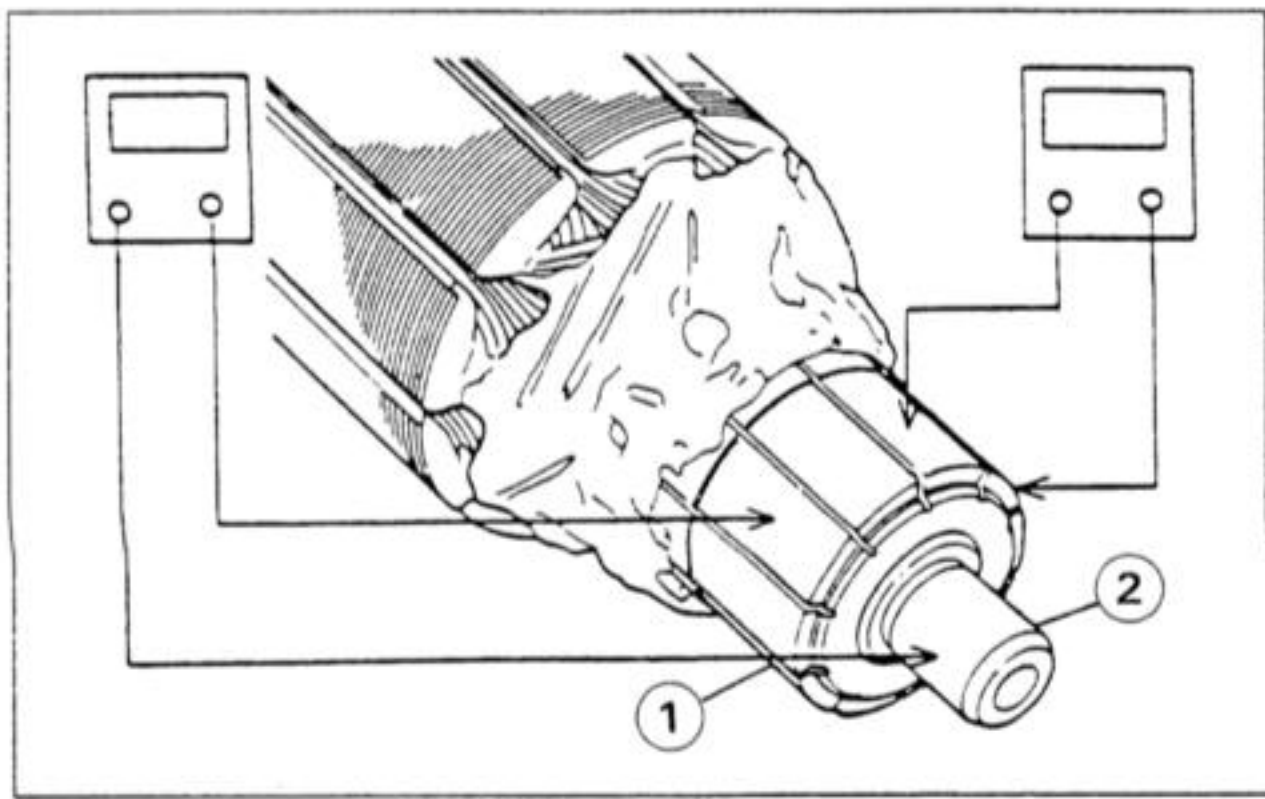

1. Segment

2. Shaft

NOTE

○ Even if the foregoing checks show the armature to be good, it may be defective in some manner not readily detectable with an ohmmeter. If all other starter motor and starter motor circuit components check good, but the starter motor still does not turn over or only turns over weakly, replace the starter motor with a new one.

Brush Lead Inspection

- Using the x 1 Ω ohmmeter range, measure the resistance as shown.
 - (+) Brush and (+) Terminal
 - (-) Brush and End Cover

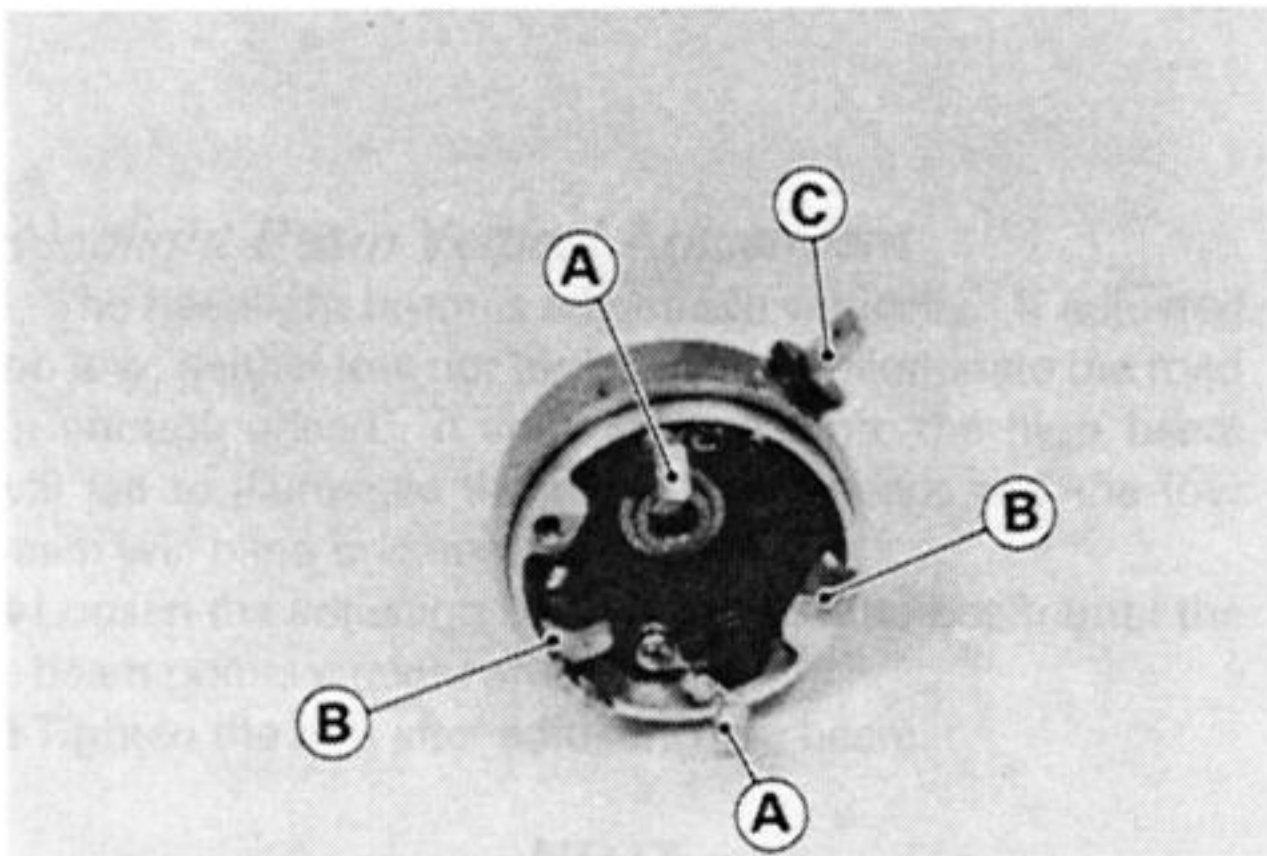

A. (-) Brush
B. (+) Brush

C. (+) Terminal

★ If there is not close to zero ohms, the brush lead has an open. Replace the terminal bolt assembly and/or the brush holder assembly.

Brush Plate and Terminal Bolt Inspection

- Using the x 1 Ω ohmmeter range, measure the resistance as shown.
 - between terminal bolt and brush plate
 - between terminal bolt and (-) brush
 - between terminal bolt and end cover
- ★ If there is any reading, the brush holder assembly and/or terminal bolt assembly have a short. Replace the brush holder assembly and the terminal bolt assembly.

Starter Relay Inspection

- Remove the left side cover.
- Remove the starter relay.
- Connect the hand tester and 12 V battery to the starter relay as shown.
- ★ If the relay does not work as specified, the relay is defective. Replace the relay.

Testing Relay

Hand Tester Range : x 1 Ω range

Criteria : When battery is connected → 0 Ω

When battery is disconnected → ∞ Ω

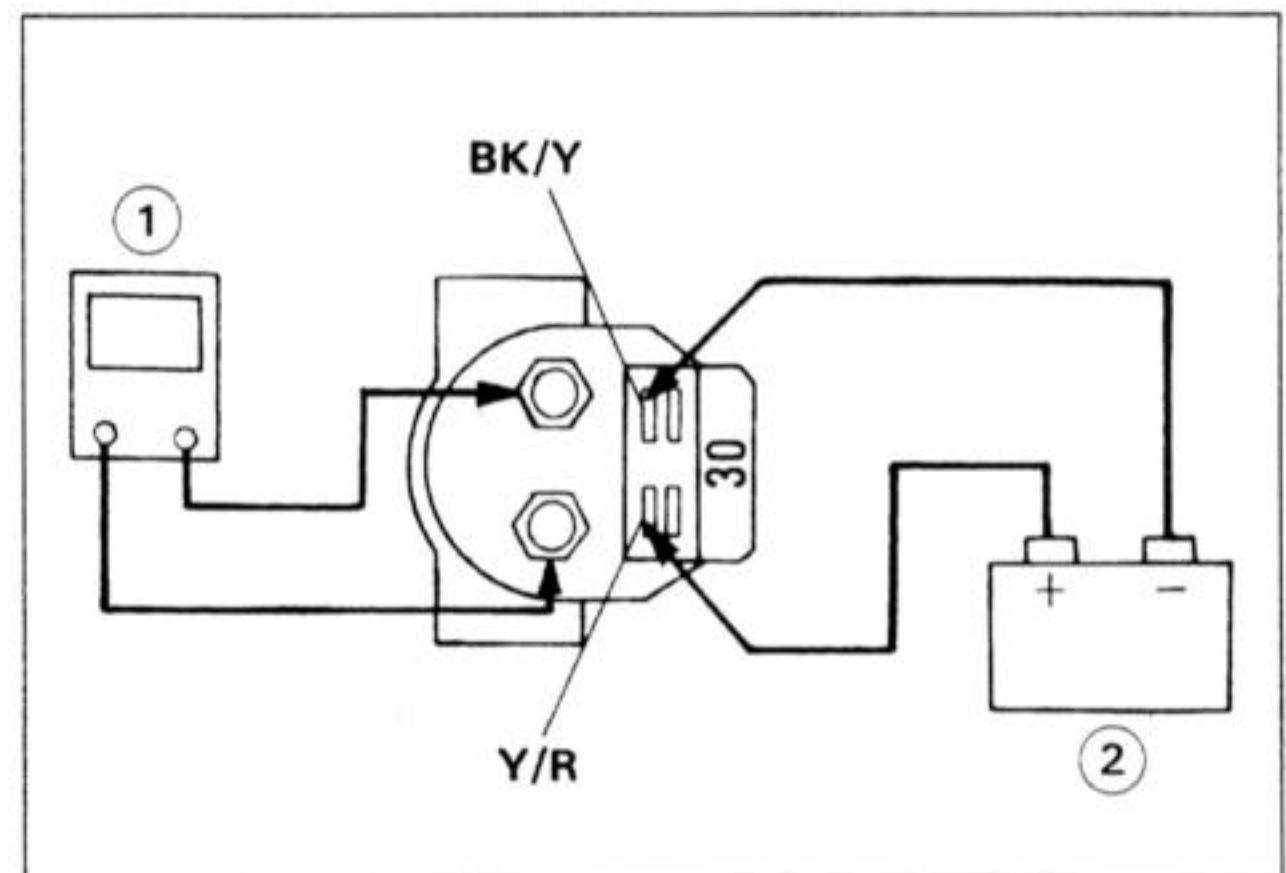

1. Tester

2. 12 V Battery

15-24 ELECTRICAL SYSTEM

Electric Starter and Fuel Pump Circuit

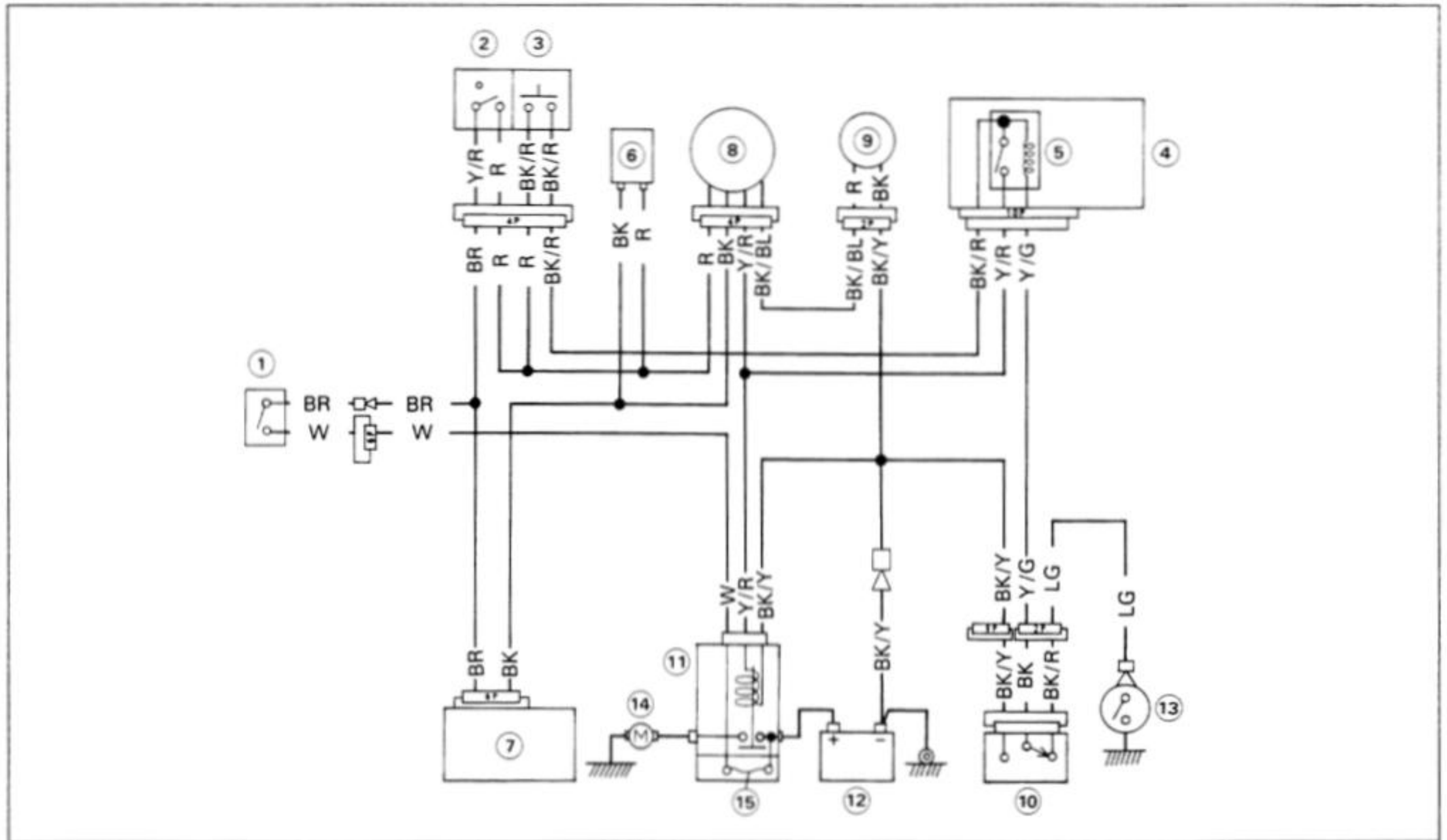

- 1. Ignition Switch
- 2. Engine Stop Switch
- 3. Starter Button
- 4. Junction Box
- 5. Starter Circuit Relay

- 6. Ignition Coil for #1, #4 Cylinder
- 7. IC Igniter
- 8. Fuel Pump Relay
- 9. Fuel Pump
- 10. Starter Lockout Switch

- 11. Starter Relay
- 12. Battery
- 13. Neutral Switch
- 14. Starter Motor
- 15. 30 A Main Fuse

Lighting System

The headlight beam is adjustable both horizontally and vertically. Headlight aiming must be correctly adjusted both for your safety as well as that of oncoming drivers. In most areas it is illegal to ride with an improperly adjusted headlight.

Headlight Beam Horizontal Adjustment

- Turn the adjusting screw on the headlight rim in or out until the beam points straight ahead. Turning the adjusting screw clockwise makes the headlight beam point to the left.

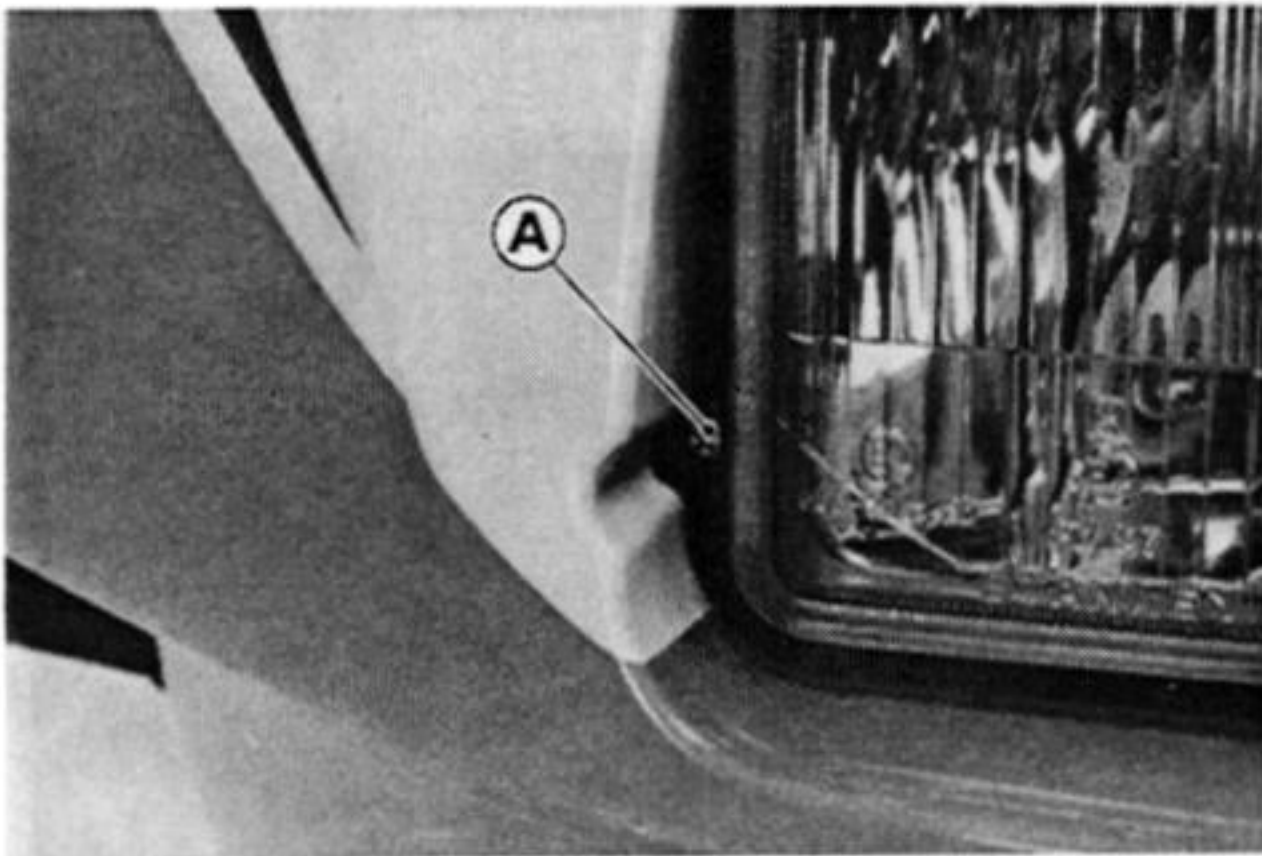

A. Adjusting Screw

Headlight Beam Vertical Adjustment

The headlight beam is adjustable vertically. If adjusted too low, neither low nor high beam will illuminate the road far enough ahead. If adjusted too high, the high beam will fail to illuminate the road close ahead, and the low beam will blind oncoming drivers.

- Loosen the adjusting bolt and adjust the beam until the beam points straight ahead.
- Tighten the bolt after adjusting the beam.

NOTE

- On high beam, the brightest point should be slightly below horizontal with the motorcycle on its wheels and the rider seated. Adjust the headlights to the proper angle according to local regulations.

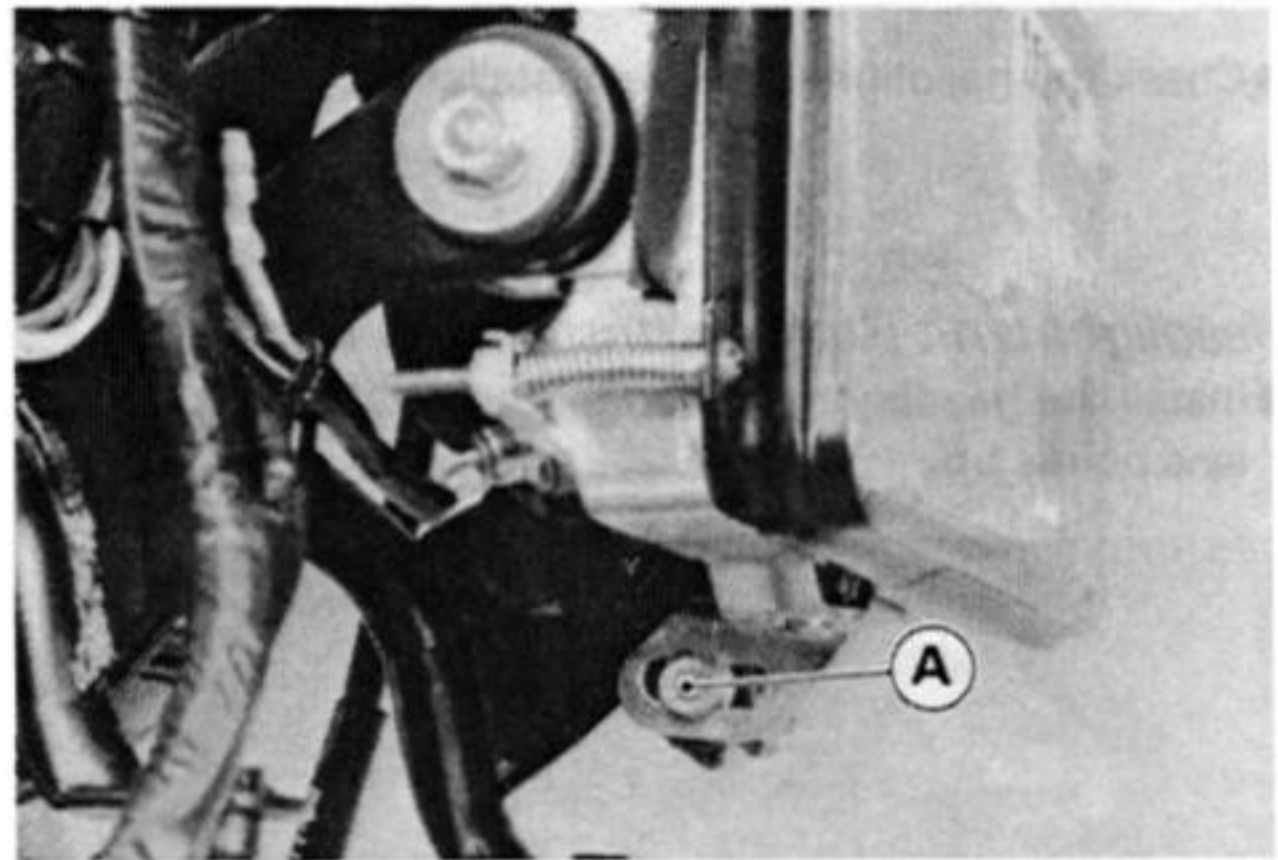
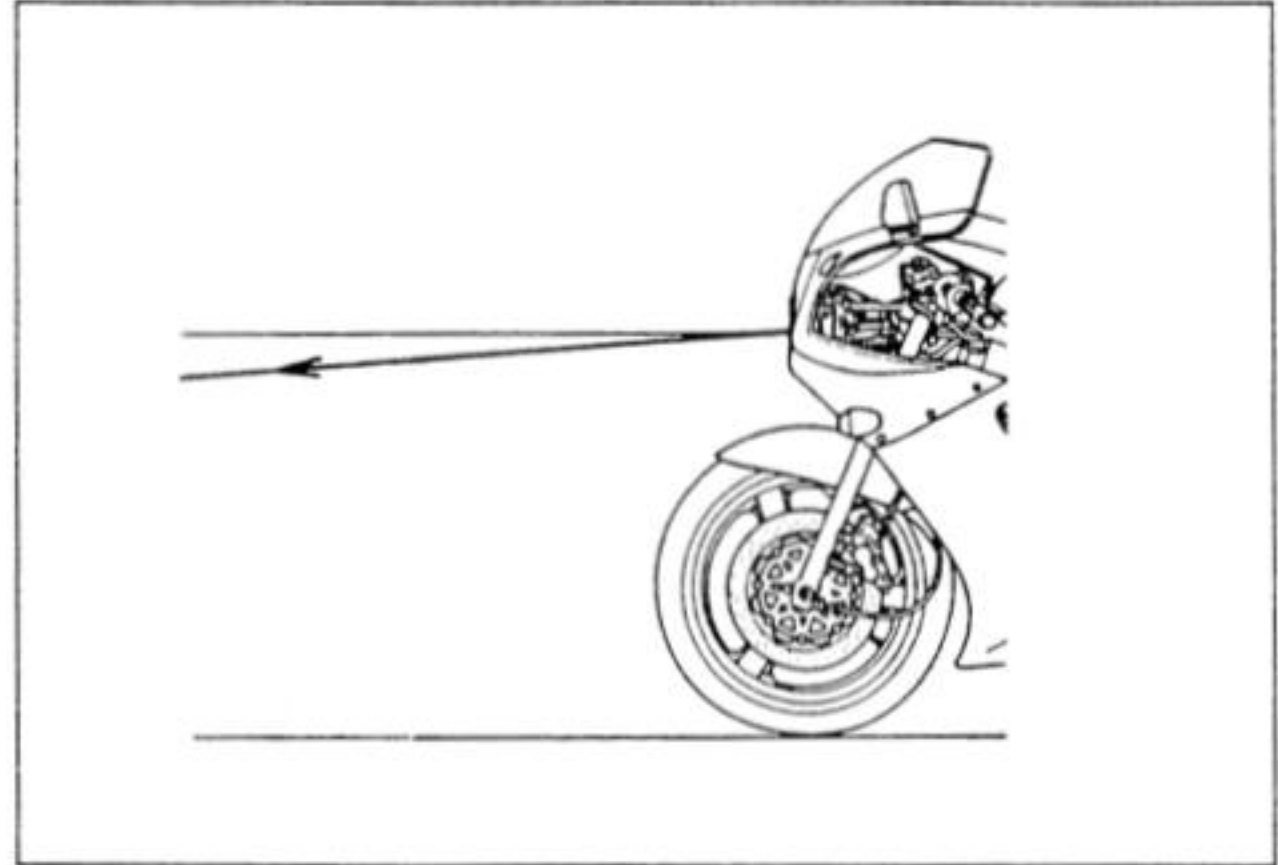

A. Adjusting Bolt

Headlight Bulb Replacement Notes

CAUTION

When handling the quartz-halogen bulbs, never touch the glass portion with bare hands. Always use a clean cloth. Oil contamination from hands or dirty rags can reduce bulb life or cause the bulb to explode.

- Install the dust cover so that the "TOP" mark point up and the cover fits onto the bulb firmly as shown.

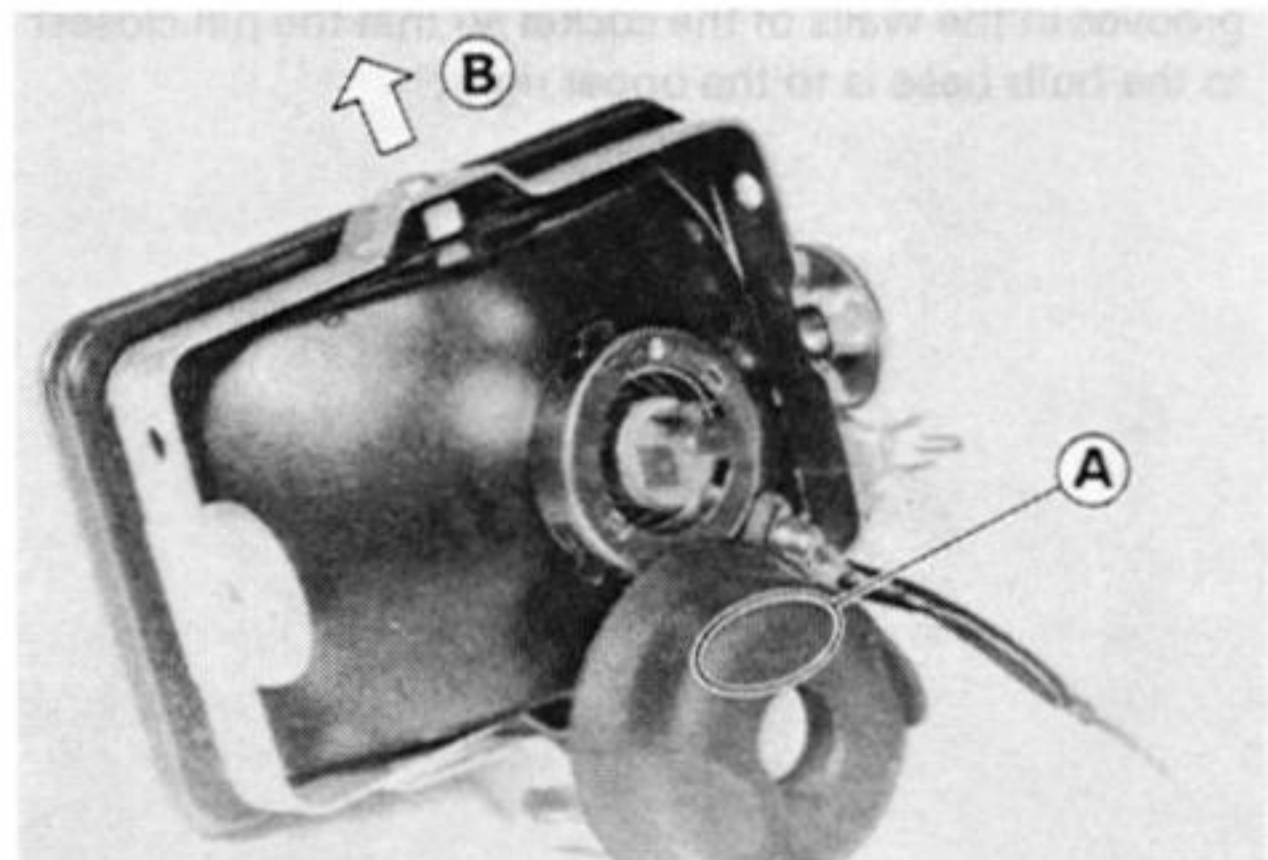

A. Top Mark

B. Up

15-26 ELECTRICAL SYSTEM

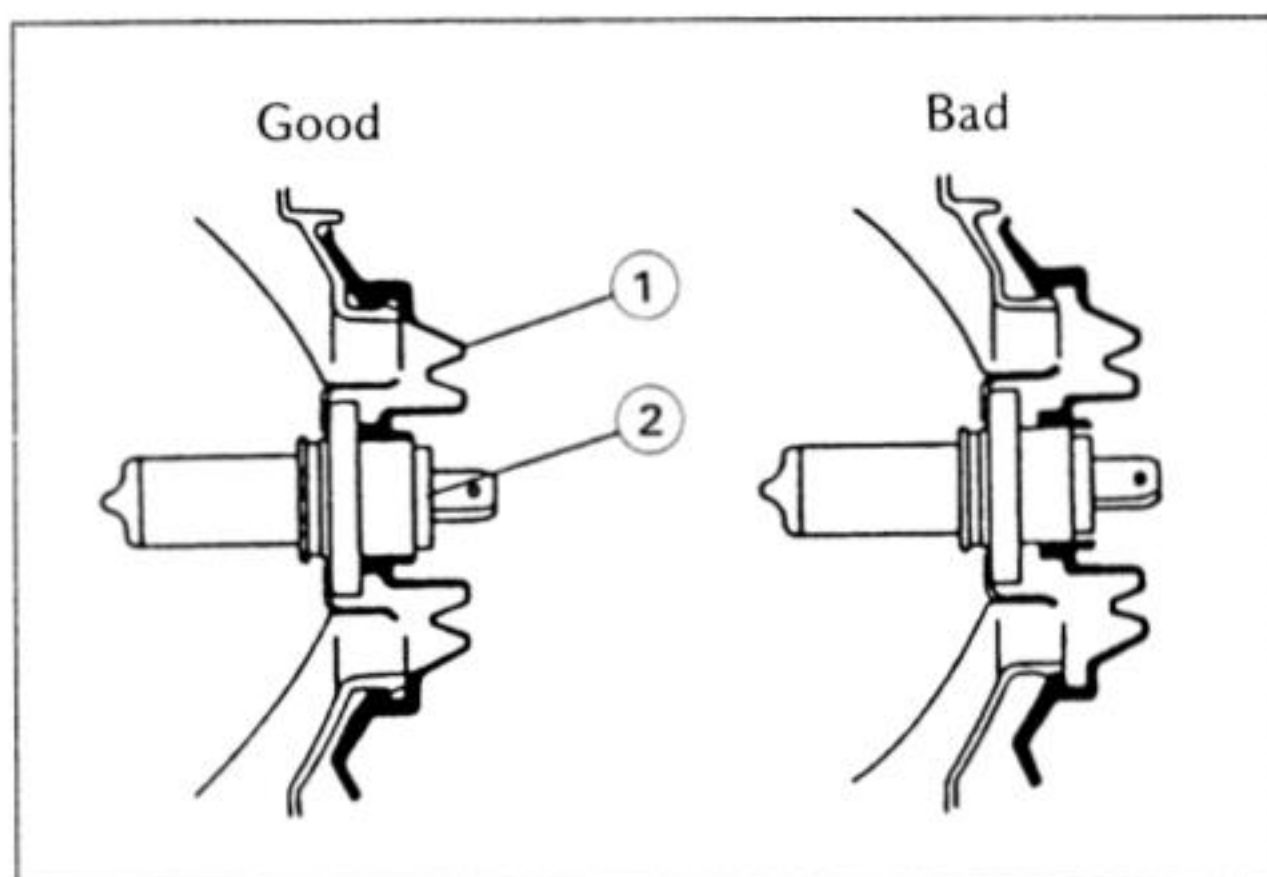

1. Dust Cover 2. Headlight Bulb

- Check the headlight aim after installation.

Headlight Unit Removal/Installation Note

- Install the headlight unit so that the "TOP" mark on the lens points up.

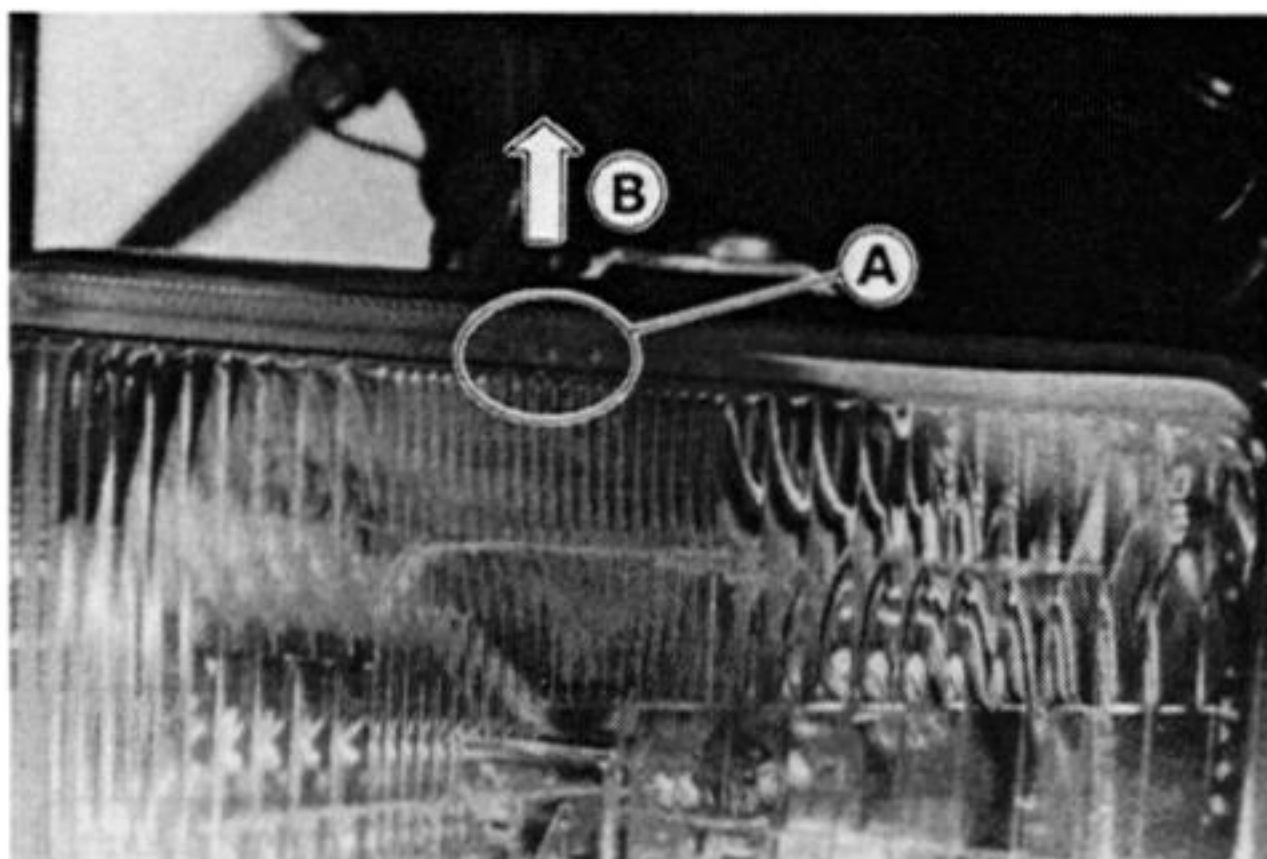

A. Top Mark B. Up

Tail/Brake Light Bulb Replacement Notes

- Insert the new bulb by aligning the pins with the grooves in the walls of the socket so that the pin closest to the bulb base is to the upper right.

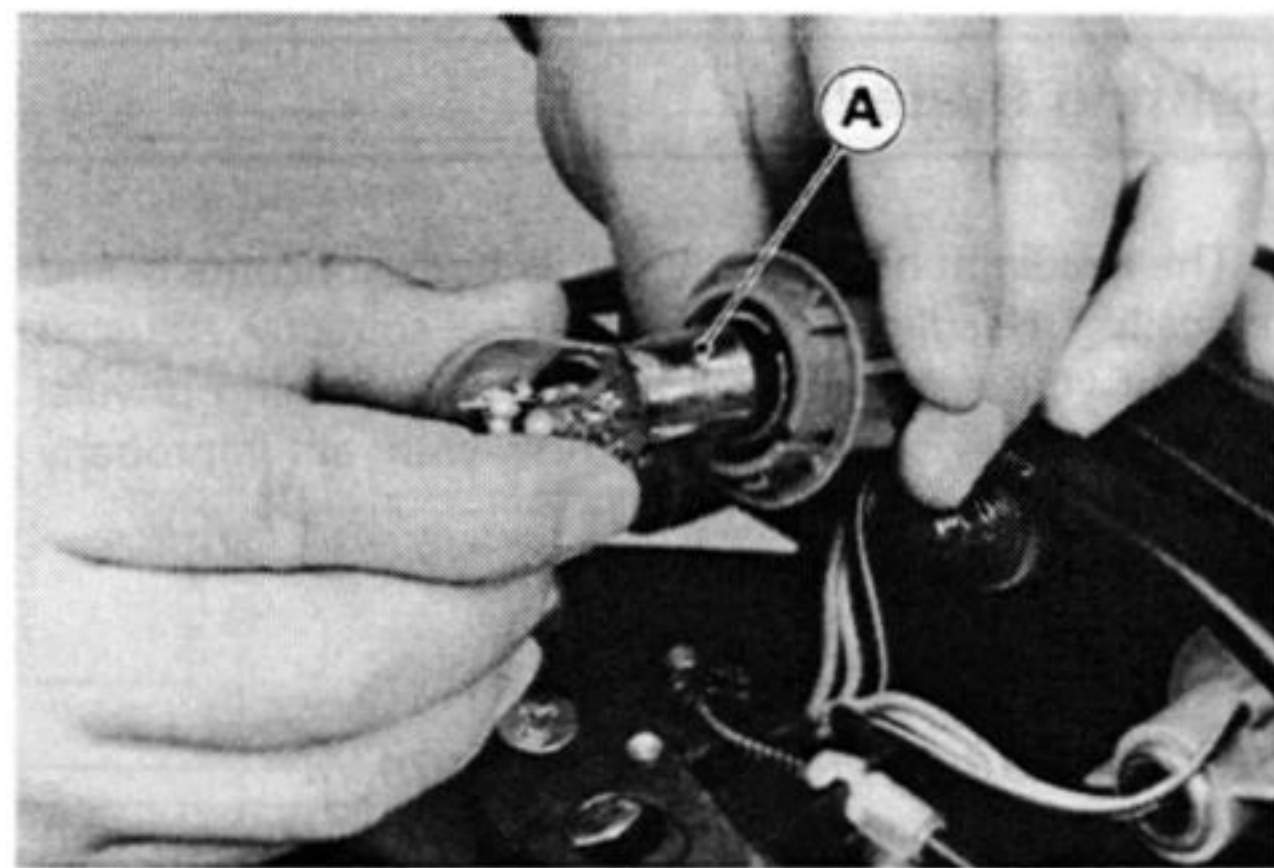

A. Pin Closest to Base.

- Insert the socket by aligning the projection on the triangular mark with the notch and turn the socket clockwise.

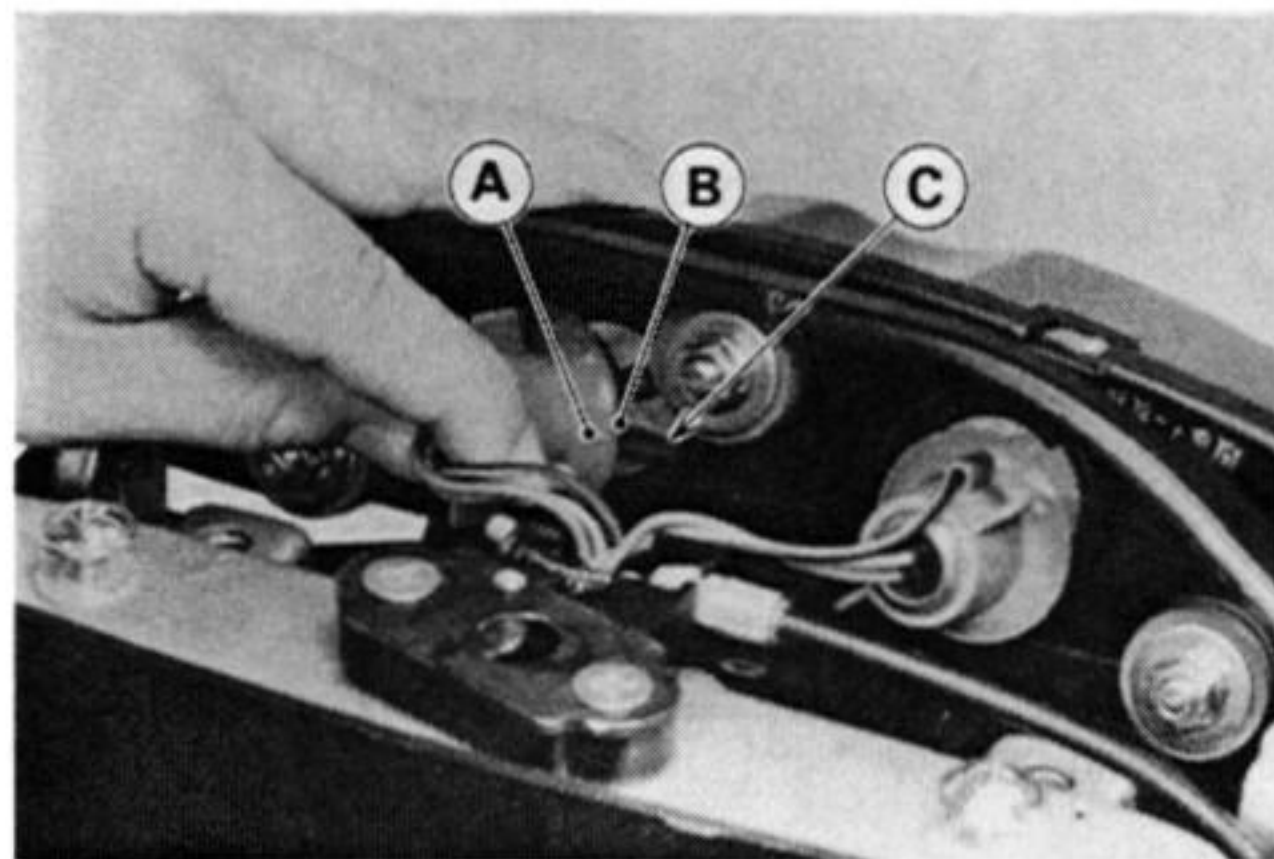

A. Triangular Mark C. Notch
B. Projection

Turn Signal Light Bulb Replacement Note

- Be careful not to overtighten the lens mounting screws.

Turn Signal Relay Inspection

- Remove the seat and right side cover.
- Take the turn signal relay out of the bracket.

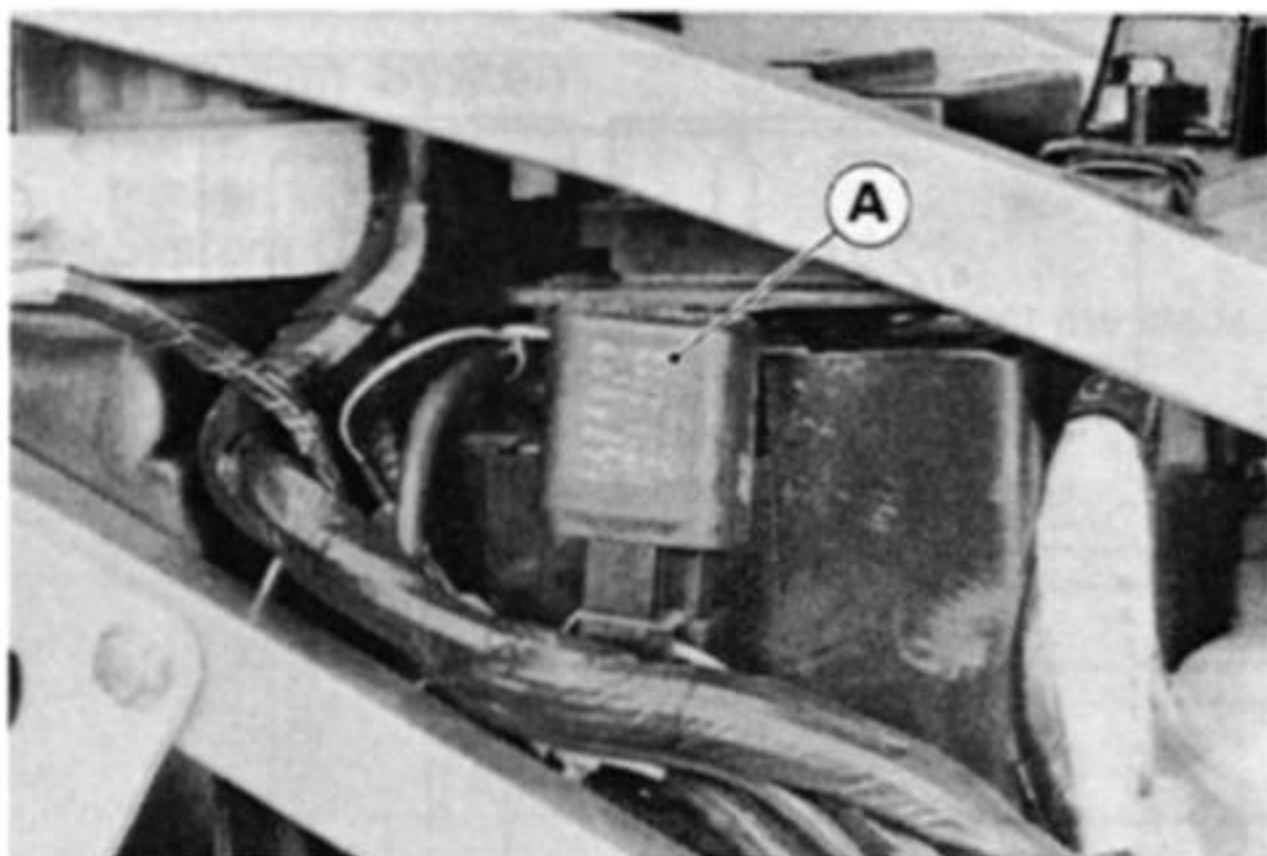

A. Turn Signal Relay

- Check the condition of the relay for the following troubles.

(1) Neither right nor left turn signals come on at all:

- Check that battery voltage is normal.
- Unplug the relay leads and use an ohmmeter to check that there is continuity (close to zero ohms) between the relay terminals.
- ★ If there is no ohmmeter reading, or if there is several ohms resistance, replace the relay with a new one.
- Turn the meter to the 25 V DC range, connect the (+) meter lead to the brown lead that was disconnected from the relay, and connect the (-) meter lead to the orange lead.
- With the ignition switch on, first switch the turn signal switch to the R and then to the L position. The meter should register battery voltage at either position.
- ★ If it does not, the fuse, ignition switch, or wiring is at fault.

(2) Both right or both left turn signals come on and stay on or flash too slowly:

- Check that battery voltage is normal.
- Check that all wiring connections are good.
- Check that the turn signal bulbs and indicator bulbs are of the correct wattage.
- ★ If all of the above check good, replace the relay.

(3) A single light on one side comes on and stays on:

- ★ Either the light that does not come on is burned out of the incorrect wattage, or the wiring is broken or improperly connected.

(4) Neither light on one side comes:

- ★ Unless both lights for that side are burned out, the trouble is with the turn signal switch.

(5) Flashing rate is too fast:

- ★ If this occurs on both the right and left sides, check that the battery is not being overcharged.
- ★ If the magneto and the battery voltage are normal, replace the turn signal relay.
- ★ If this occurs on only one side, one or both of the turn signal bulbs are of too high a wattage.

15-28 ELECTRICAL SYSTEM

Headlight Circuit (U.K. Model) :

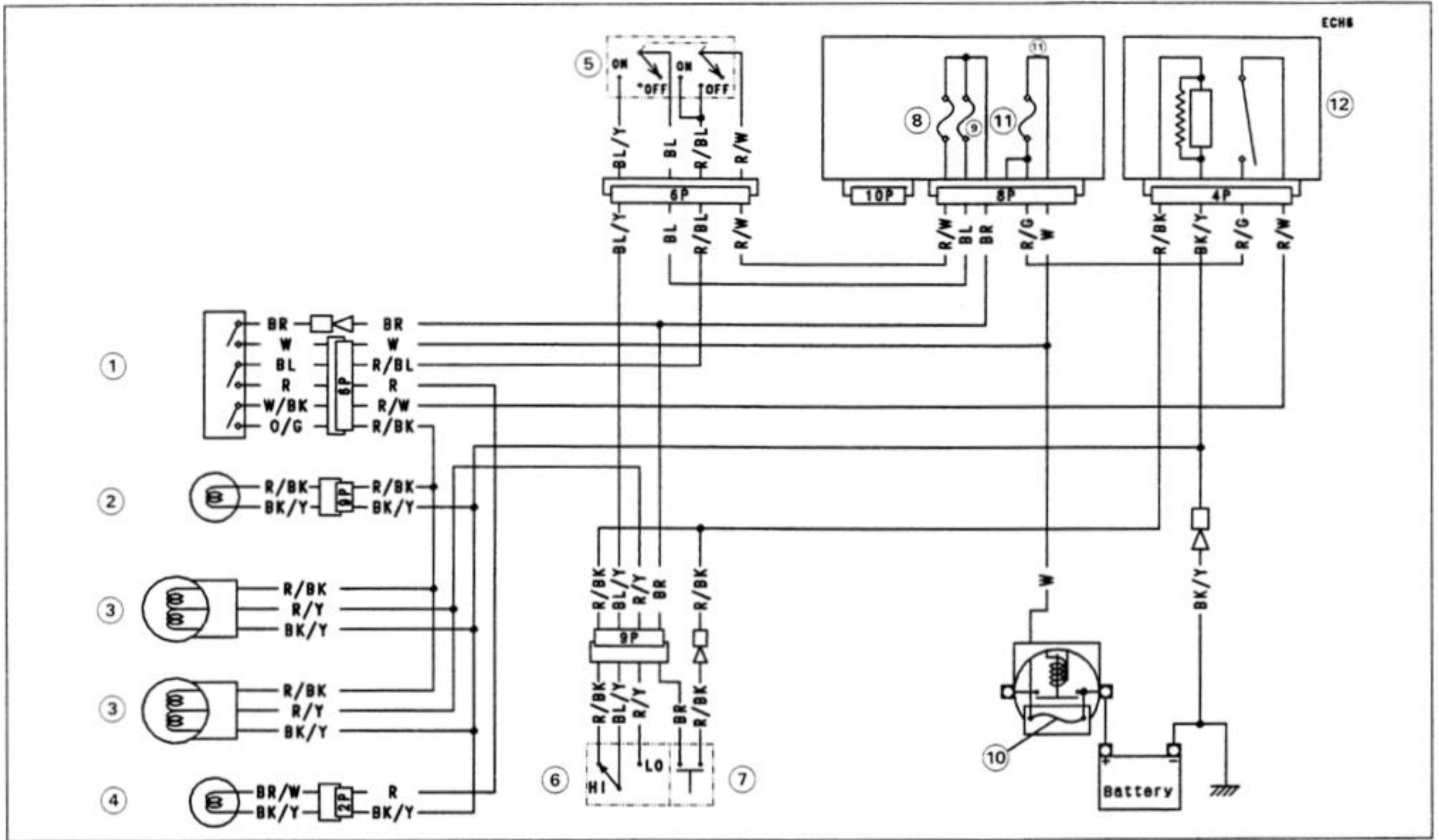

Headlight Circuit (other than U.K. Model) :

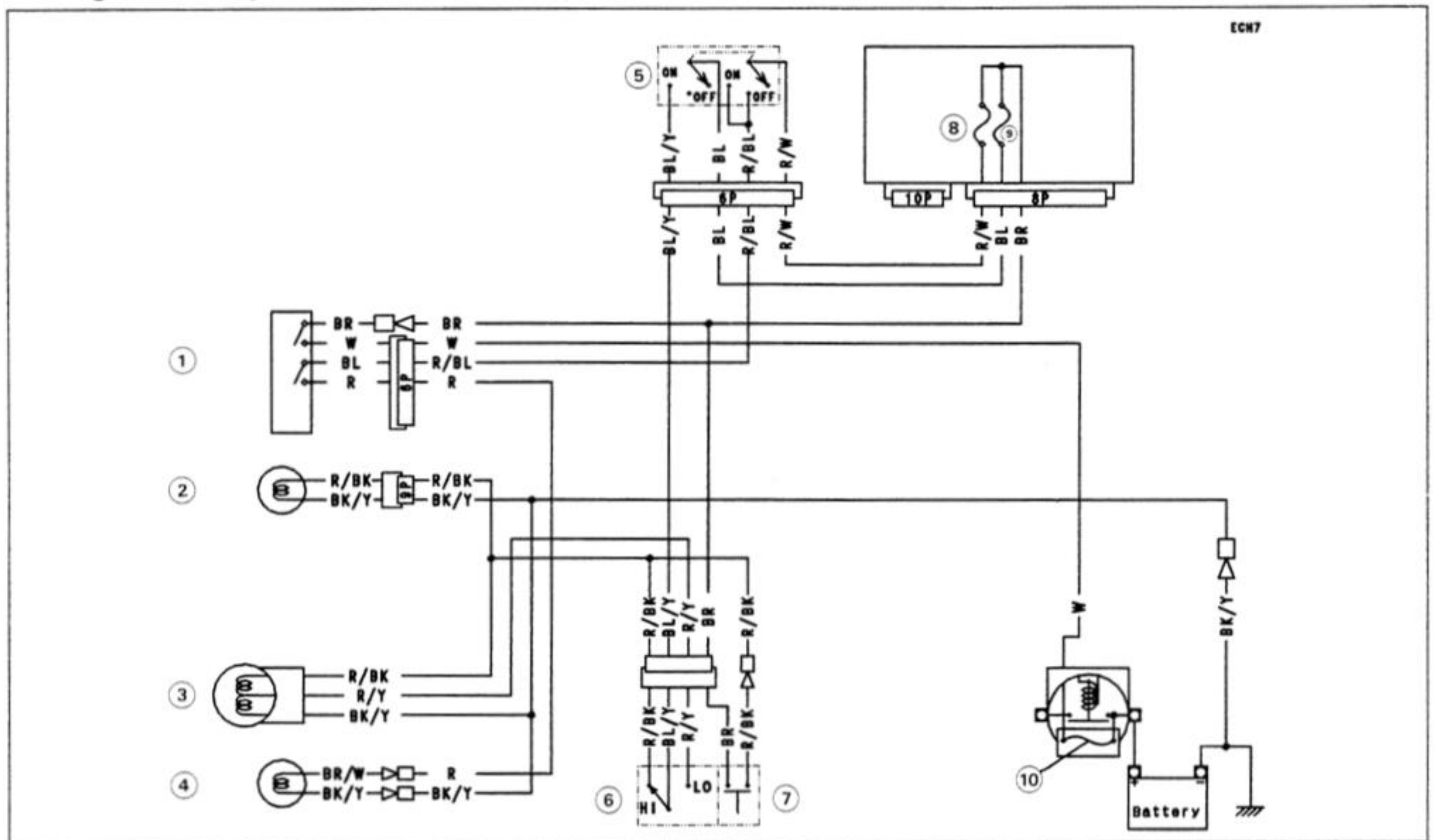

1. Ignition Switch
2. High Beam Indicator Light
3. Headlight
4. City Light

5. Headlight Switch
6. Dimmer Switch
7. Passing Button
8. 10A Taillight Fuse

9. 10A Headlight Fuse
10. 30A Main Fuse in Starter Relay
11. 15A High Beam Fuse
12. Headlight Relay

Cooling Fan System

Fan System Circuit Inspection

- Remove the left lower fairing and disconnect the leads from the radiator fan switch.

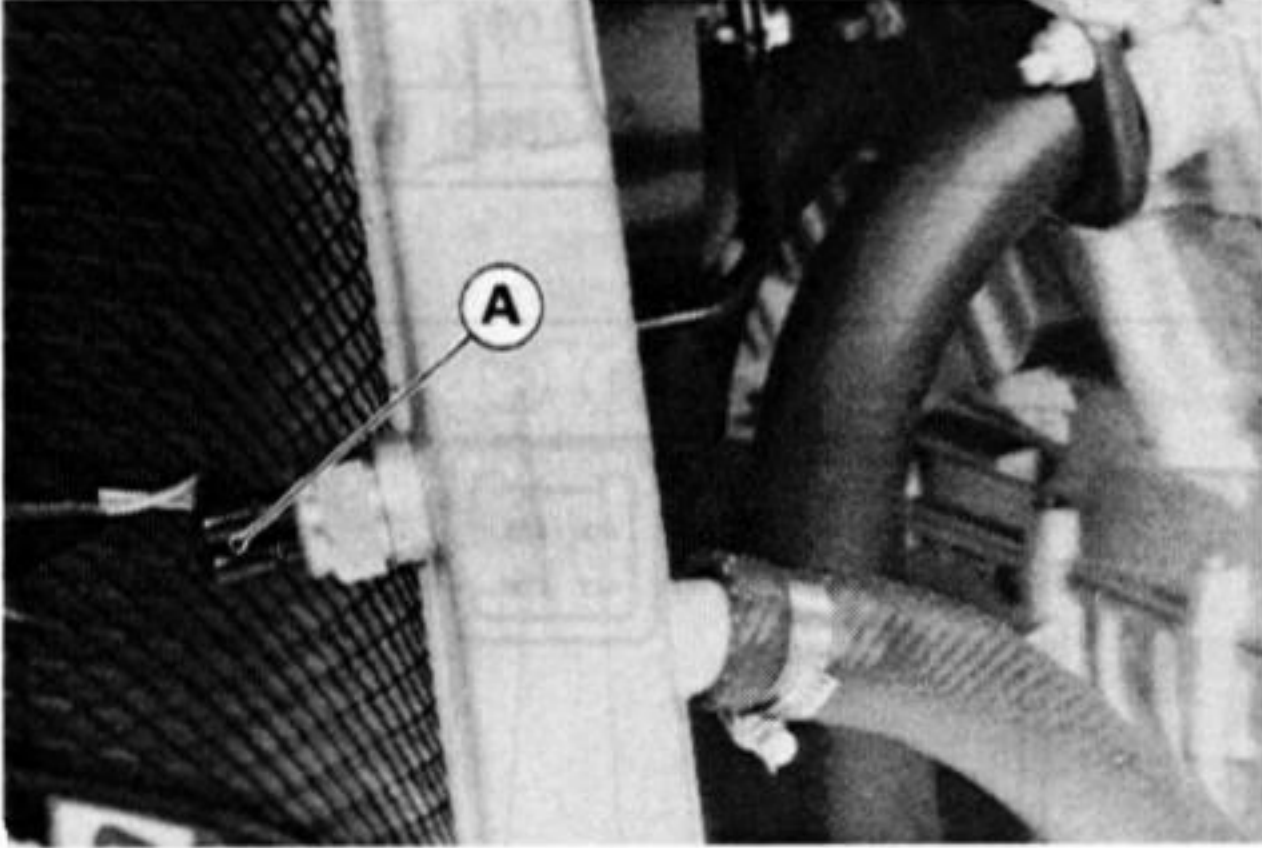

A. Fan Switch Terminals

- Using an auxiliary wire, connect the radiator fan switch leads.
- ★ If the fan rotates, inspect the fan switch.
- ★ If the fan does not rotate, inspect the following.
 - Fan Fuse (Junction Box)
 - Headlight Circuit
 - Leads and Connectors
 - Main Fuse
 - Fan

Fan Inspection

- Remove the following.
 - Air Cleaner Housing
- Disconnect the 2-pin connector in the fan leads.

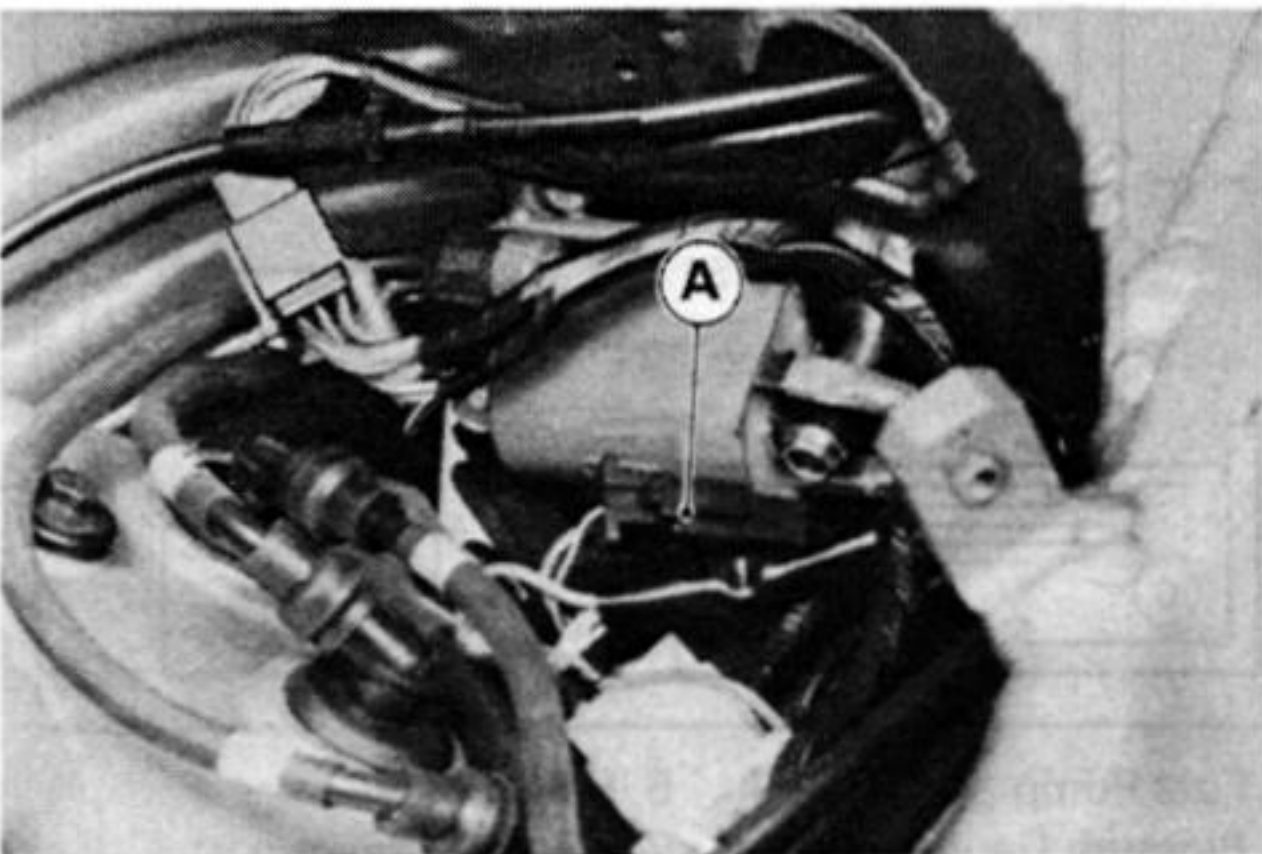

A. Fan Connector

- Using two auxiliary wires, supply battery power to the fan.
- ★ If the fan does not rotate at this time, the fan is defective and must be replaced.

Fan Installation

- Installation is the reverse of removal.

Cooling Fan Circuit

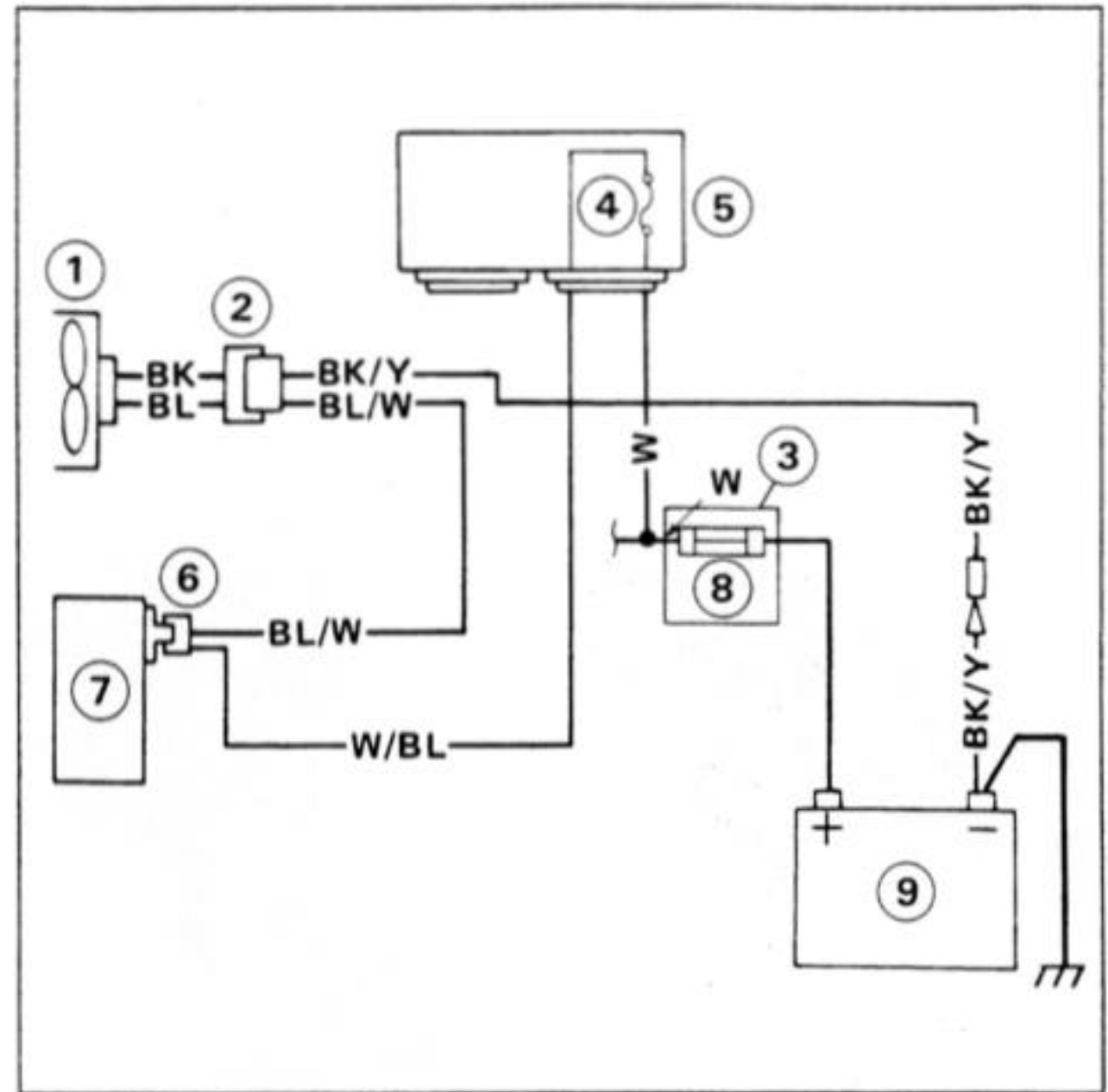

- | | |
|--------------------|------------------|
| 1. Cooling Fan | 6. Fan Switch |
| 2. 2-pin Connector | 7. Radiator |
| 3. Starter Relay | 8. Main Fuse 30A |
| 4. Fan Fuse 10A | 9. Battery |
| 5. Junction Box | |

15-30 ELECTRICAL SYSTEM

Fuel Pump

The pump operates when the starter button is pushed on or the engine is running.

● Refer to the Starter Motor section for the Fuel Pump Wiring Diagram.

When fuel level in the float bowl is low, the fuel pump operates to supply fuel into the float bowl.

When the fuel reaches a certain level, the fuel pressure rises, and the fuel pump stops.

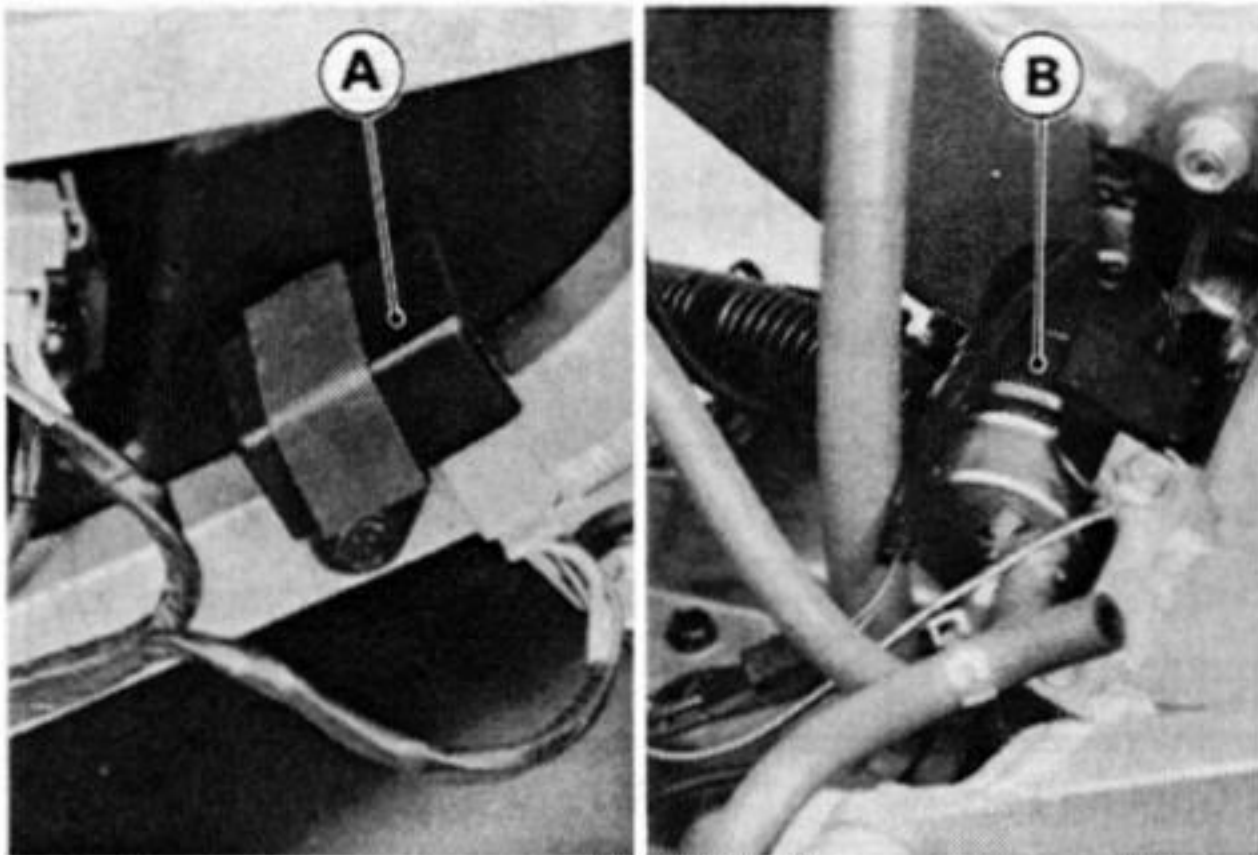

A. Pump Relay

B. Fuel Pump

Fuel Pump Relay Inspection

- Remove the side cover assembly and take out the fuel pump relay.
- Set the hand tester (special tool: 57001-1394) to the $\times 1k\Omega$ range and make the measurements shown in the table.
- ★ If the tester readings are not as specified, replace the fuel pump relay.
- ★ If the tester readings are not normal, check the fuel pump operation.

CAUTION

Use only Hand Tester 57001-983 for this test. An ohmmeter other than the Kawasaki Hand Tester may show different readings. If a megger or a meter with a large-capacity battery is used, the pump relay will be damaged.

Fuel Pump Relay Internal Resistance

Range $\times 1k\Omega$	Tester (+) Lead Connection			
	1	2	3	4
Tester (-) Lead Connection	1	∞	∞	∞
	2	∞	∞	∞
	3	∞	10 - 100	∞
	4	∞	20 - 200	1 - 5

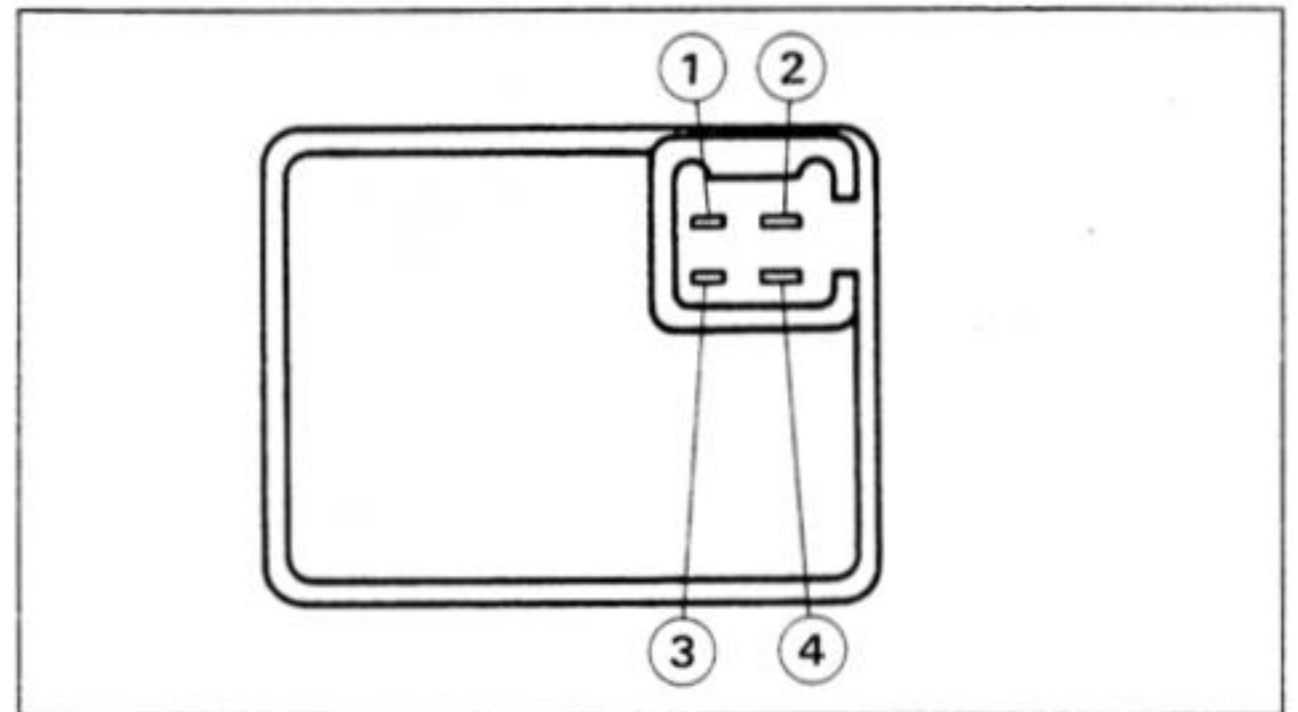

Pump Operation Inspection

- Remove the fuel pump with the fuel filter.
- Prepare a container filled with kerosene.
- Prepare the rubber hoses, and connect them to the pump fittings.
- Connect the suitable pressure gauge to the outlet hose as shown.

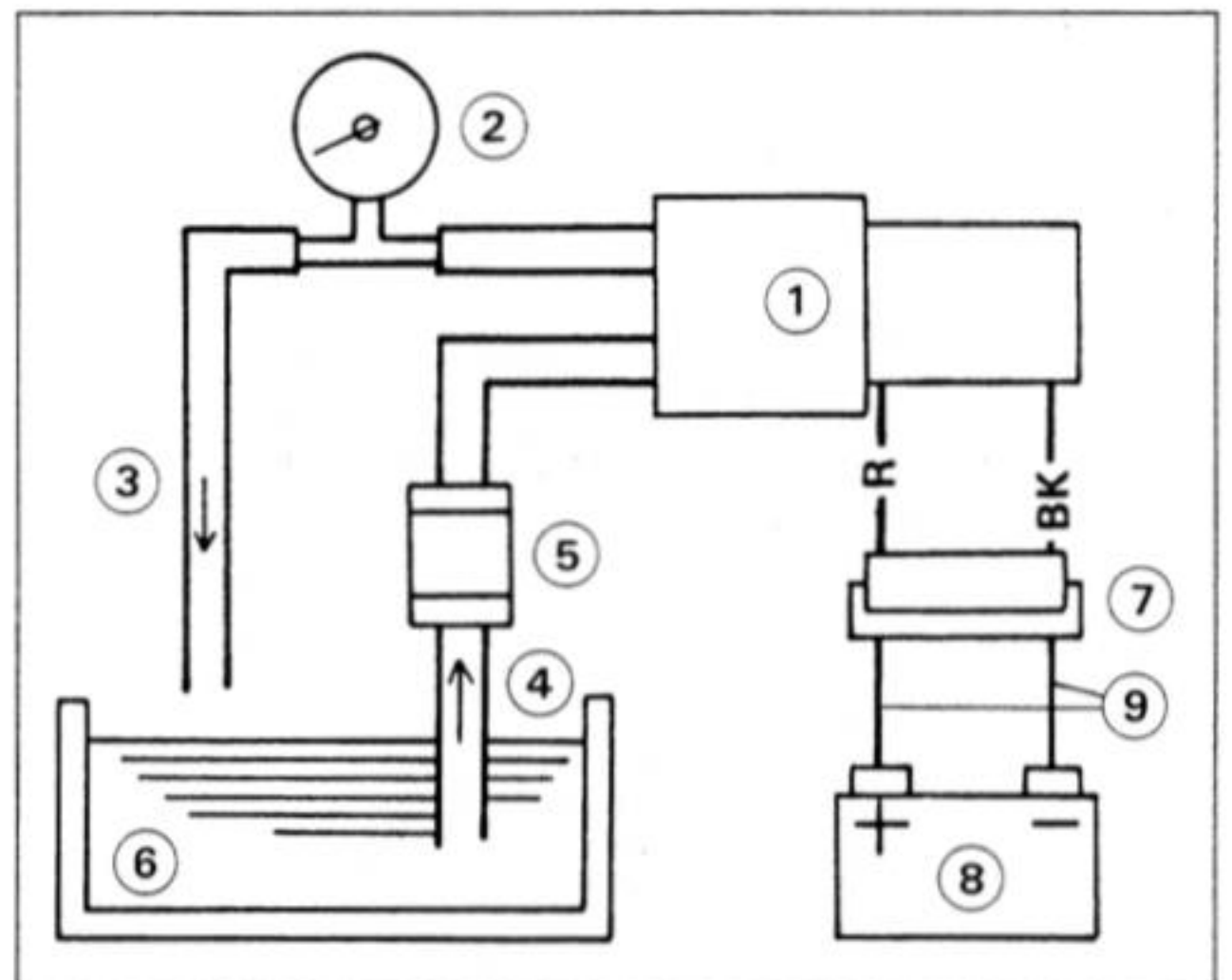

- | | |
|-------------------|--------------------|
| 1. Fuel Pump | 6. Kerosene |
| 2. Pressure Gauge | 7. 2-Pin Connector |
| 3. Outlet Hose | 8. Battery |
| 4. Inlet Hose | 9. Auxiliary Leads |
| 5. Fuel Filter | |

- Connect the pump leads to the battery using auxiliary wires as shown.

★ If the pump operates, check the pump relay.

- ★ If the pump does not operate, the pump is defective.
- ★ If the pump operates and the pump relay is normal, close the outlet hose while operating the fuel pump.
- When the pump stops, read the pressure gauge.
- ★ If the pressure gauge reading is out of the specified pressure, the pump is defective.

Fuel Pump Pressure

Standard 11 ~ 16 kPa
 (0.11 ~ 0.16 kg/cm², 1.6 ~ 2.3 psi)

Meters, Gauges

Removal

- Remove the following.
 - Upper Fairing
 - Headlight Unit
 - Speedometer Cable Upper End
 - Wiring Connectors
- Remove the meter unit by taking off the mounting nuts.

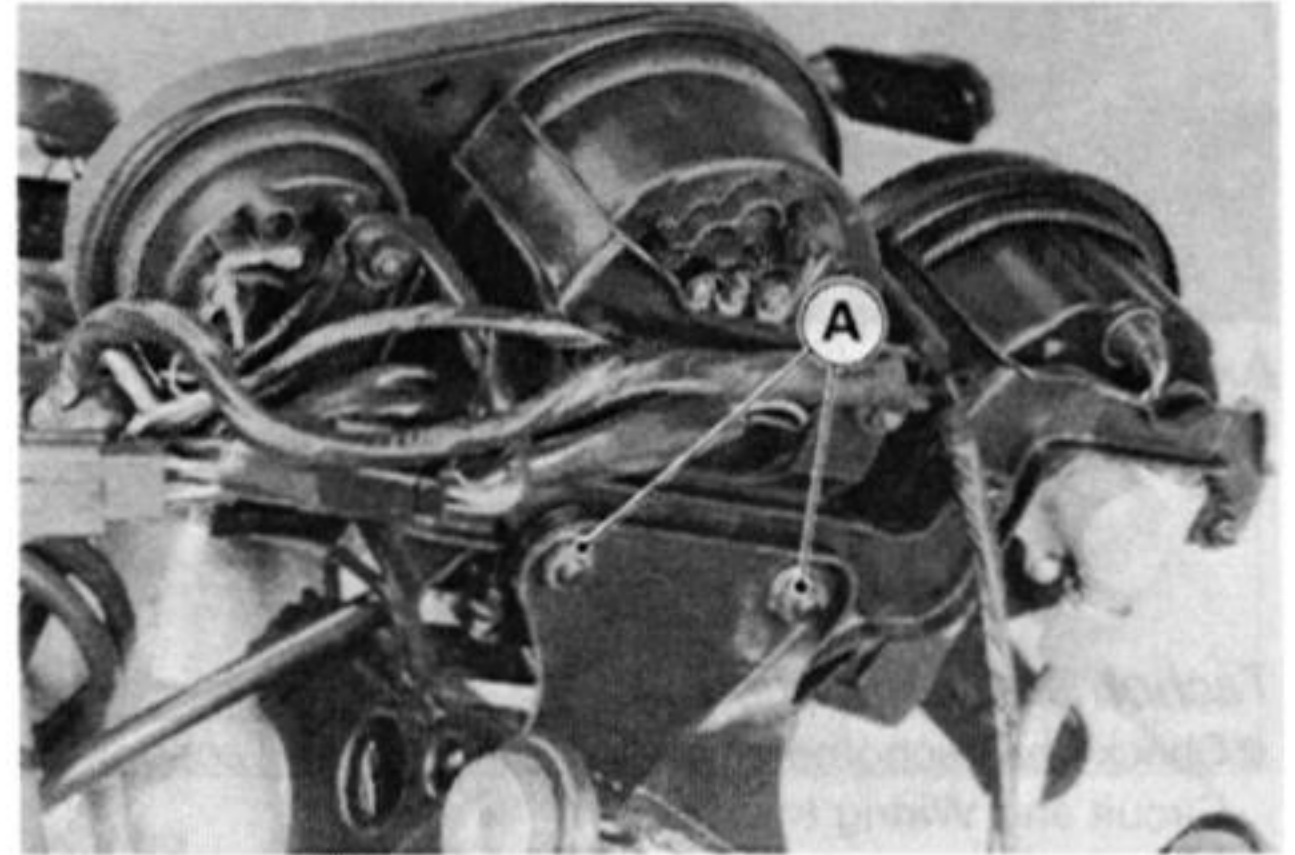

A. Meter Mounting Nuts

CAUTION

Place the meter or gauge so that the face is up. If a meter or gauge is left upside down or sideways for any length of time it will malfunction.

Bulb Replacement

- To remove the wedge-base type bulb, pull the bulb out of the socket.

CAUTION

Do not use bulb rated for greater wattage than the specified value.
 Do not turn the bulb to prevent damage to the bulb.

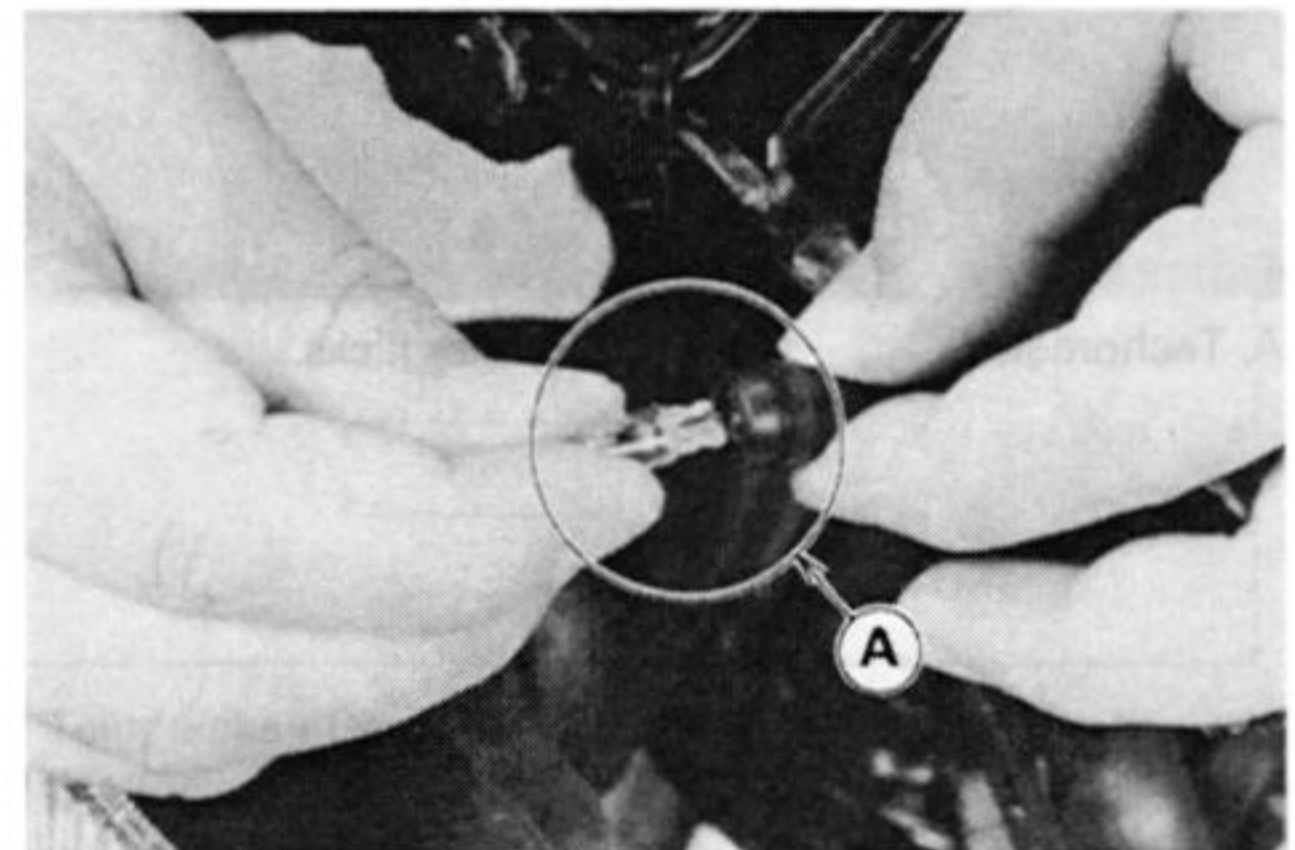

A. Pull the bulb.

15-32 ELECTRICAL SYSTEM

Meter, Gauge Assembly Note

- Install each lead on the original position shown.

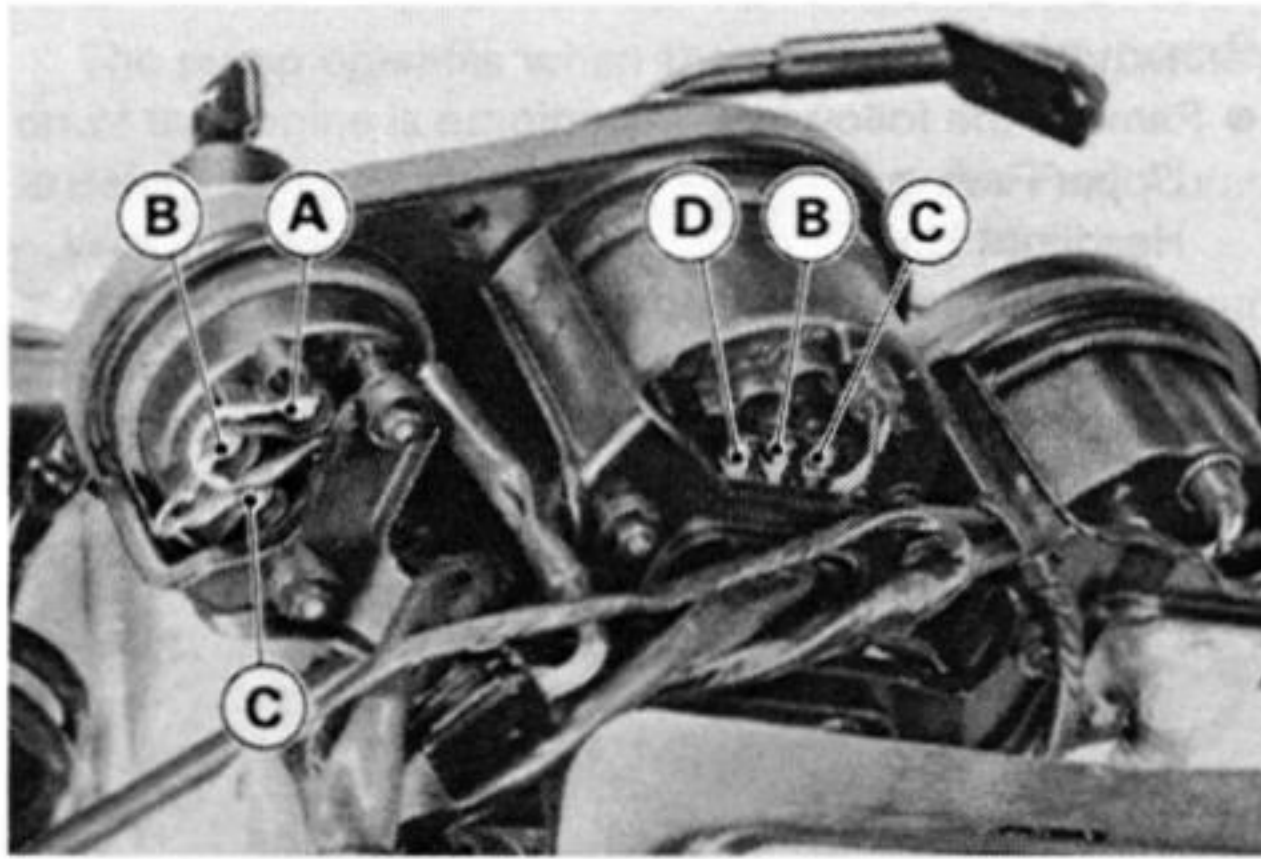

A. Y/W Lead
B. BK/Y Lead
C. BR Lead
D. BK Lead

Tachometer Inspection

- Check the tachometer circuit wiring (see Tachometer Circuit and Wiring Inspection).
- ★ If all wiring and components other than the tachometer unit check out good, the unit is suspect. Check the unit as shown.
- Remove the air cleaner housing.
- Remove the BK lead of the ignition coil.
- Turn the ignition switch ON.
- Open or connect the BK lead to the battery positive terminal using an auxiliary lead. Then the pointer should flick.
- Turn the ignition switch OFF.
- ★ If the pointer does not flick, replace the tachometer unit.

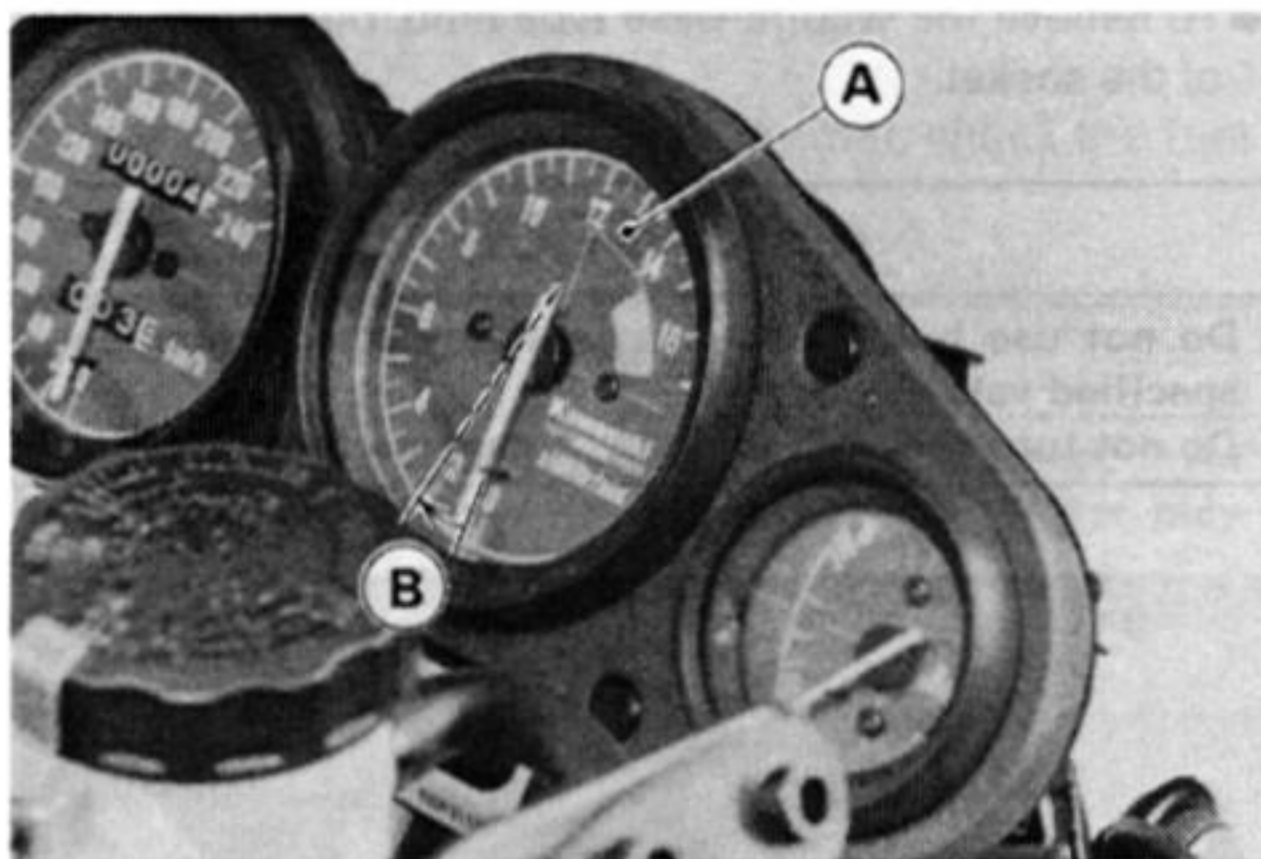

A. Tachometer
B. Pointer flicks.

Water Temperature Gauge Operation Inspection

- Prepare an auxiliary wire, and check the operation of the gauge.

Gauge Operation Test

Ignition Switch Position: ON

Wire Location: Water temperature sensor female connector (disconnected)

Results: Gauge should read C when sensor wire is opened.
Gauge should read H when sensor wire is grounded to engine.

CAUTION

Do not ground the wiring longer than necessary. After the pointer swings to the H position, stop the test. Otherwise the gauge could be damaged.

- ★ If these readings are not correct, the trouble is with the gauge and/or wiring.

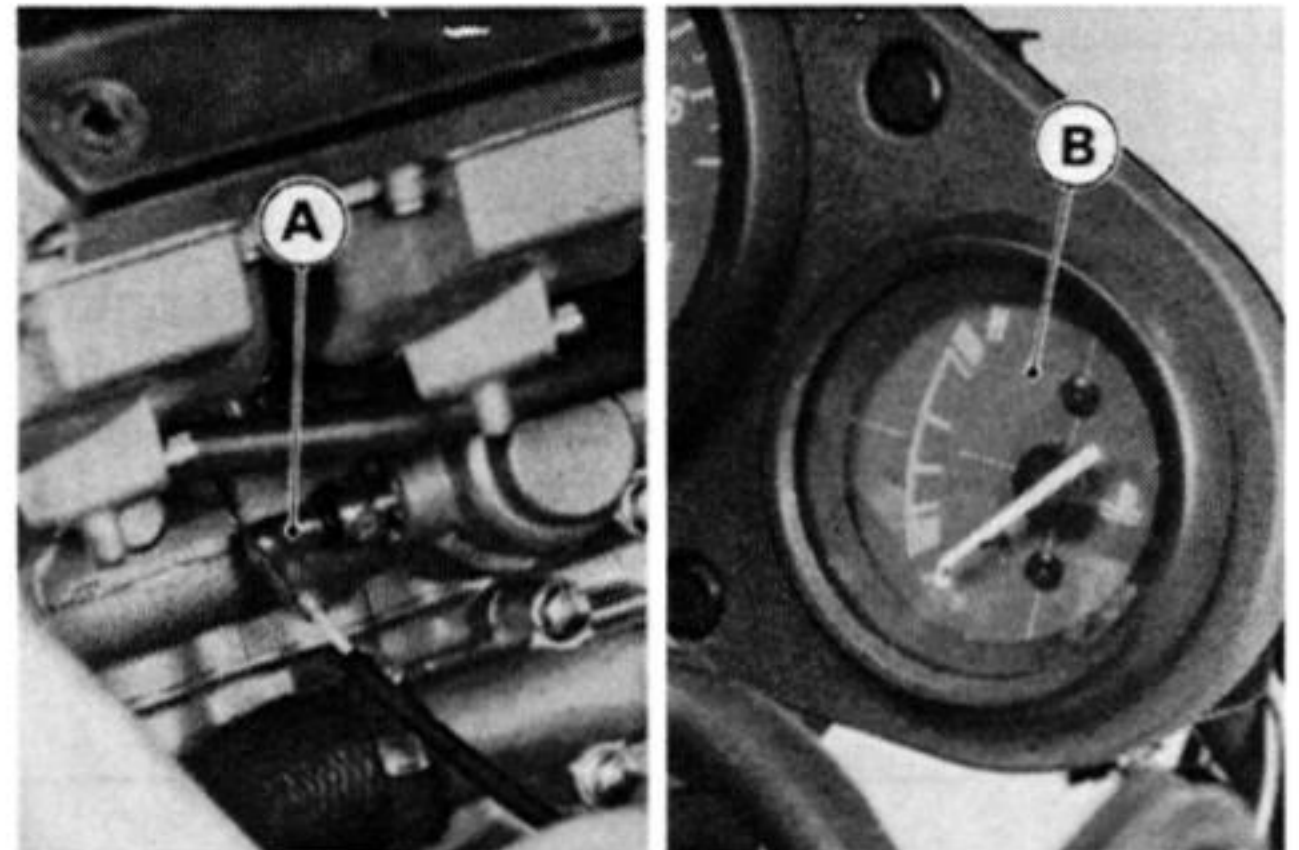

A. Sensor Connector
B. Water Temperature Gauge

- Check the water temperature gauge circuit wiring (see Wiring Inspection).
- If all wiring and components other than the water temperature gauge unit check out good, the gauge is defective.

Tachometer Circuit

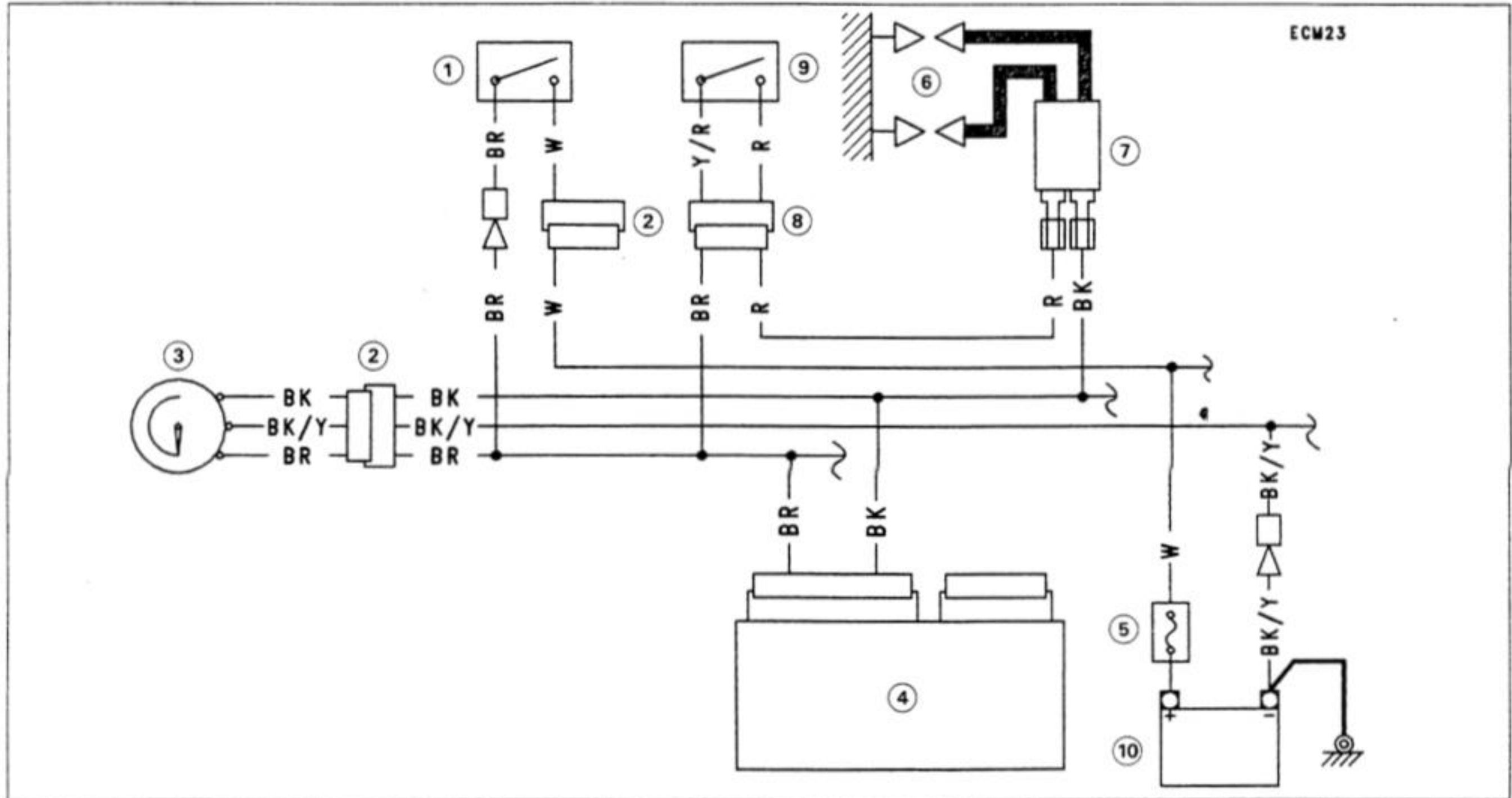

- 1. Ignition Switch
- 2. 6-Pin Connector
- 3. Tachometer
- 4. IC Igniter
- 5. 30A Main Fuse in Starter Relay
- 6. Spark Plug
- 7. Ignition Coil (#1, #4)
- 8. 4-Pin Connector
- 9. Engine Stop Switch
- 10. Battery

Water Temperature Gauge Circuit

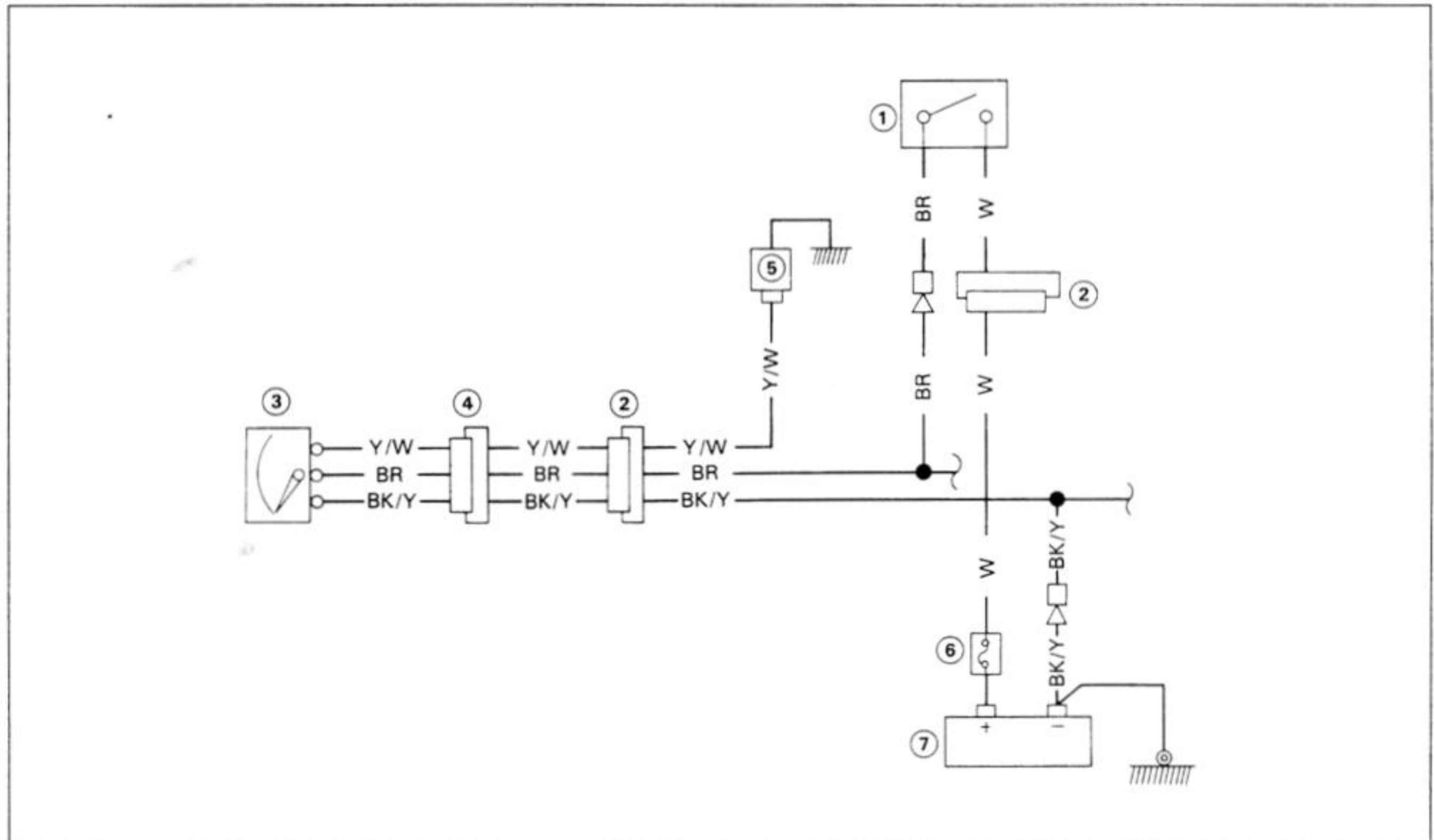

- 1. Ignition Switch
- 2. 6-Pin Connector
- 3. Water Temperature Gauge
- 4. 4-Pin Connector
- 5. Water Temperature Sensor
- 6. 30A Main Fuse in Starter Relay
- 7. Battery

15-34 ELECTRICAL SYSTEM

Water Temperature Sensor Inspection

- Suspend the sensor in a container of coolant so that the temperature sensing projection and threaded portion are submerged.
- Using an ohmmeter, measure the internal resistance of the sensor across the terminal and the body at the temperatures shown in the table.

Water Temperature Sensor

80°C (175°F):	47 ~ 57 Ω
100°C (212°F):	25 ~ 30 Ω

NOTE

- The sensor and thermometer must not touch the container sides or bottom.

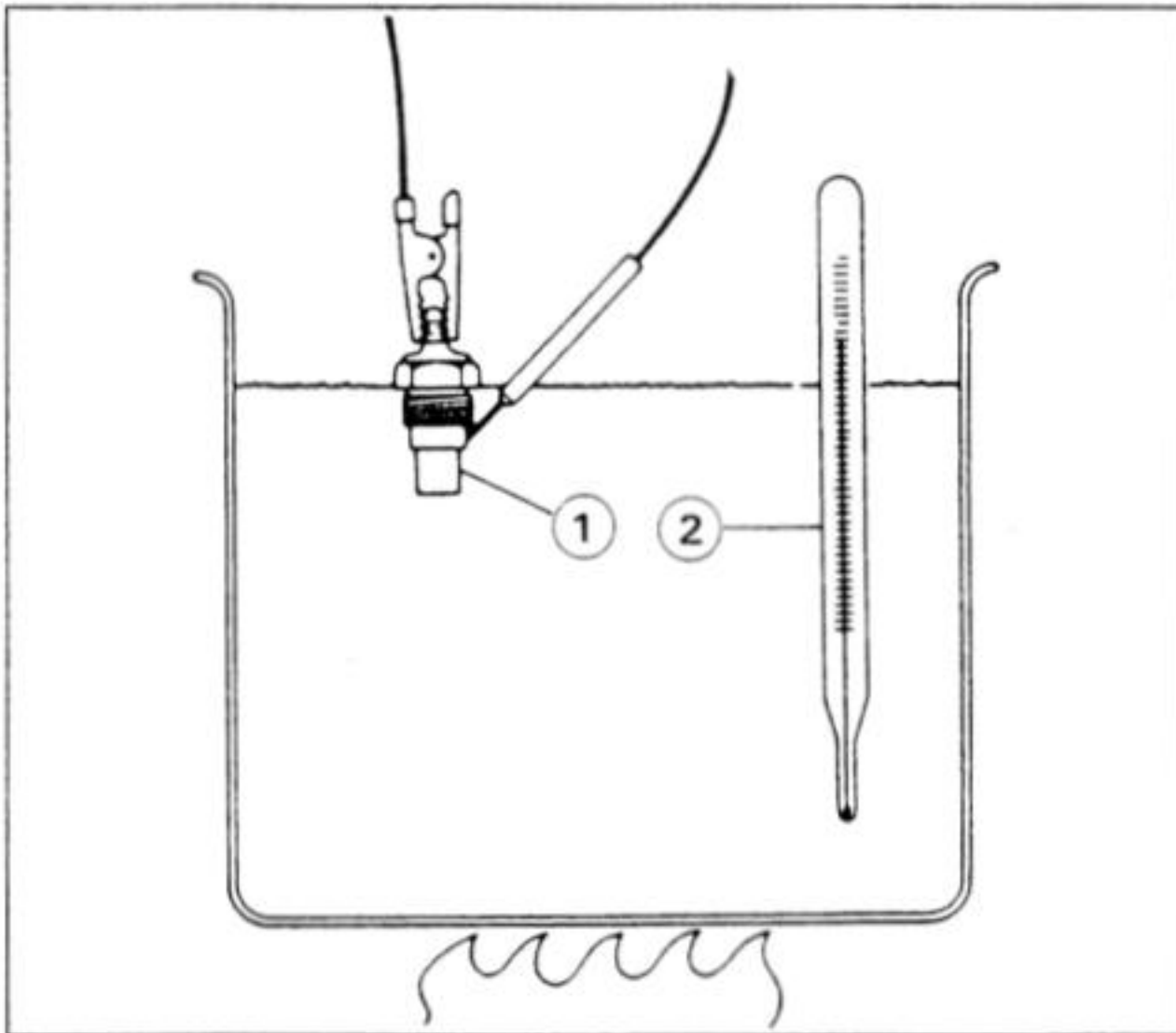

1. Water Temperature Sensor 2. Thermometer

- ★ If the ohmmeter does not show the specified values, replace the sensor.

Fan Switch Inspection

- Using an ohmmeter, check to see that only the connections shown in the table have continuity (about zero ohms).
- ★ If the switch has an open or short, repair or replace it with new one.

Fan Switch Resistance

- Rising temperature:
From OFF to ON at 84 ~ 90°C
(183 ~ 194°F)
- Falling temperature:
From ON to OFF at 71 ~ 77°C
(160 ~ 170°F)
- ON : Less than 0.5 Ω
- OFF : More than 1 M Ω

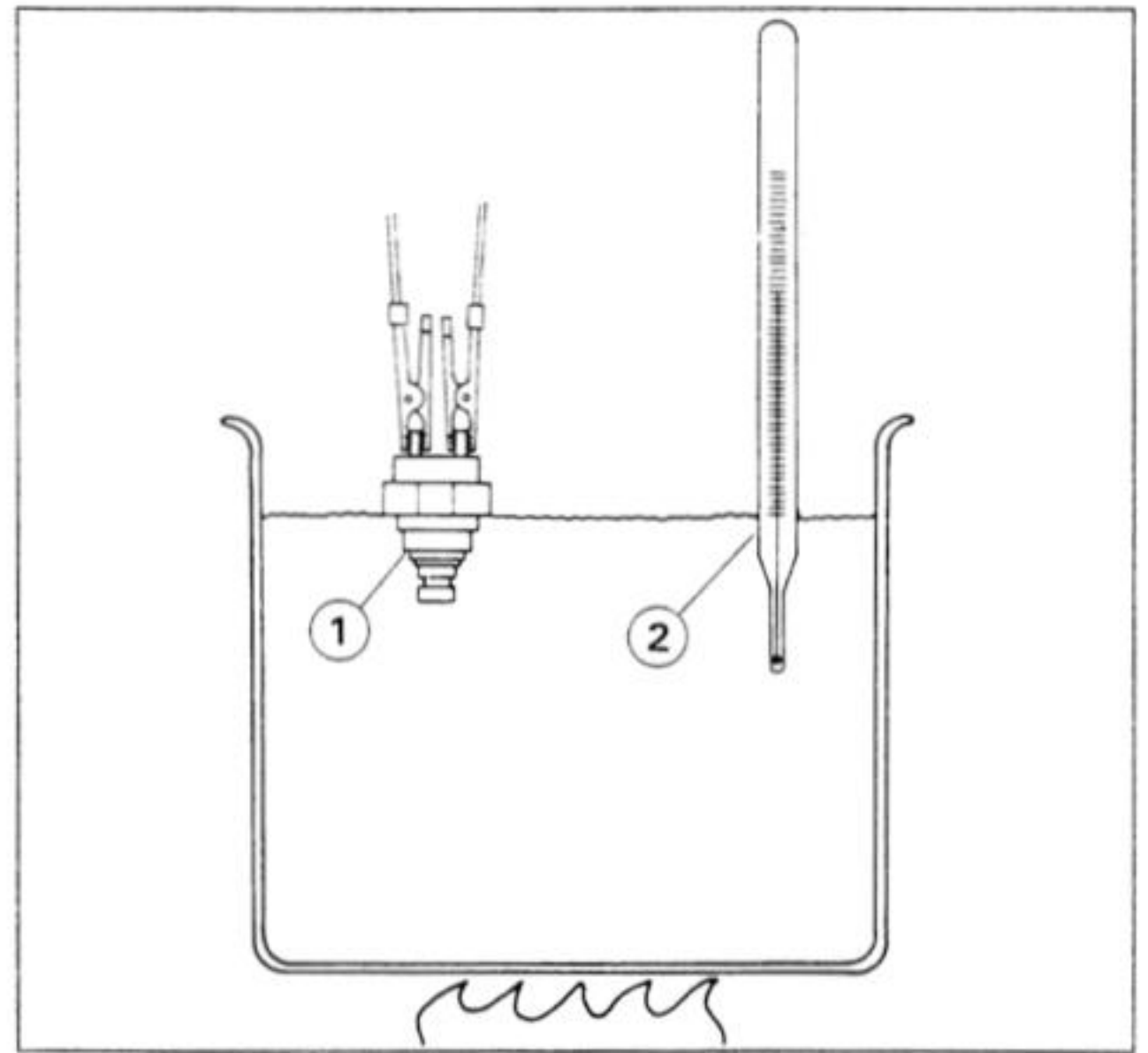

1. Fan Switch

2. Thermometer

- Suspend the switch in a container of coolant so that the temperature-sensing projection and threaded portion are submerged.
- Suspend an accurate thermometer in the coolant.

NOTE

- The switch and thermometer must not touch the container sides or bottom.
- Place the container over a source of heat and gradually raise the temperature of the coolant while stirring the coolant gently.

Junction Box

The junction box has fuses, relays, and diodes. The relays and diodes can not be removed.

Fuse Removal

- Remove the seats and the left side cover.
- Unlock the hook to lift up the locking arm.
- Pull the fuses straight out of the junction box with needle nose pliers.
- Pull out the main fuse from the starter relay.

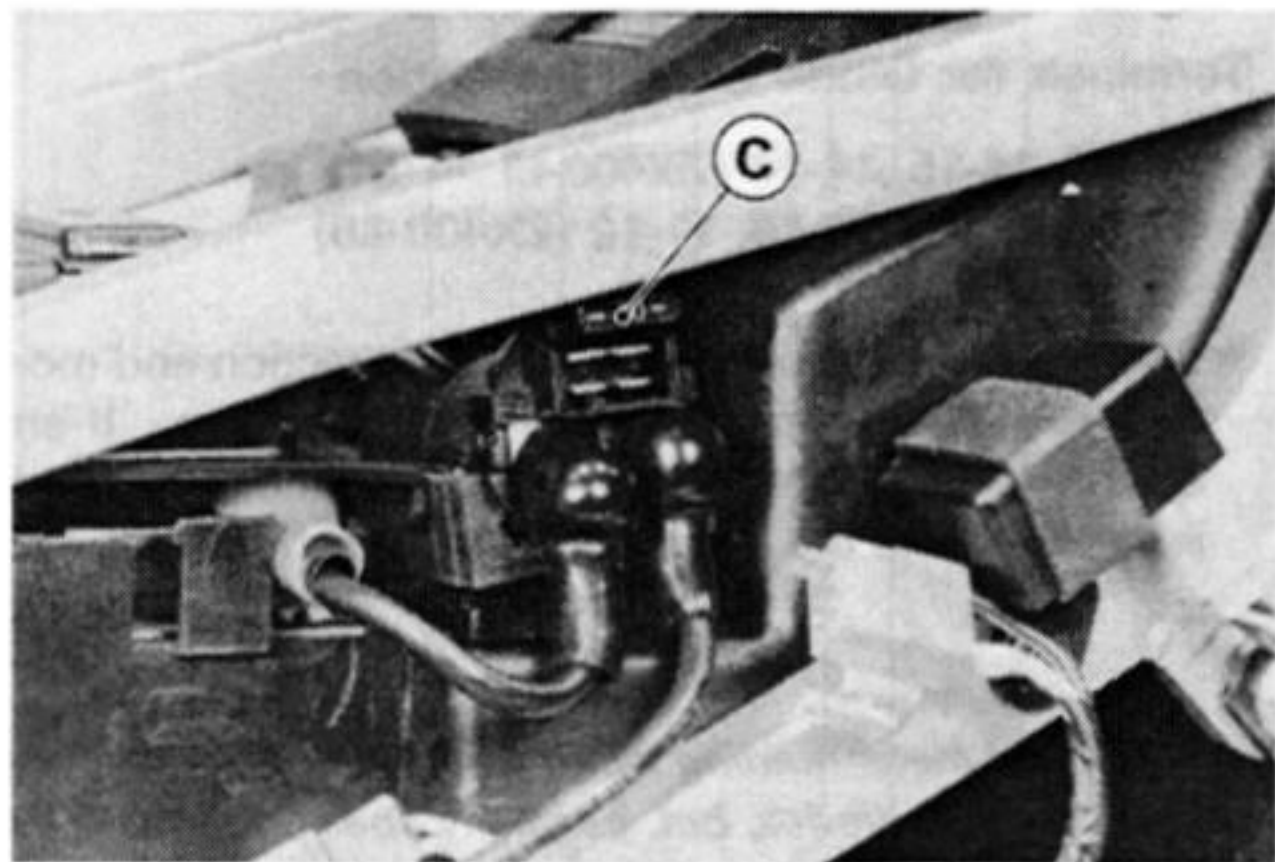
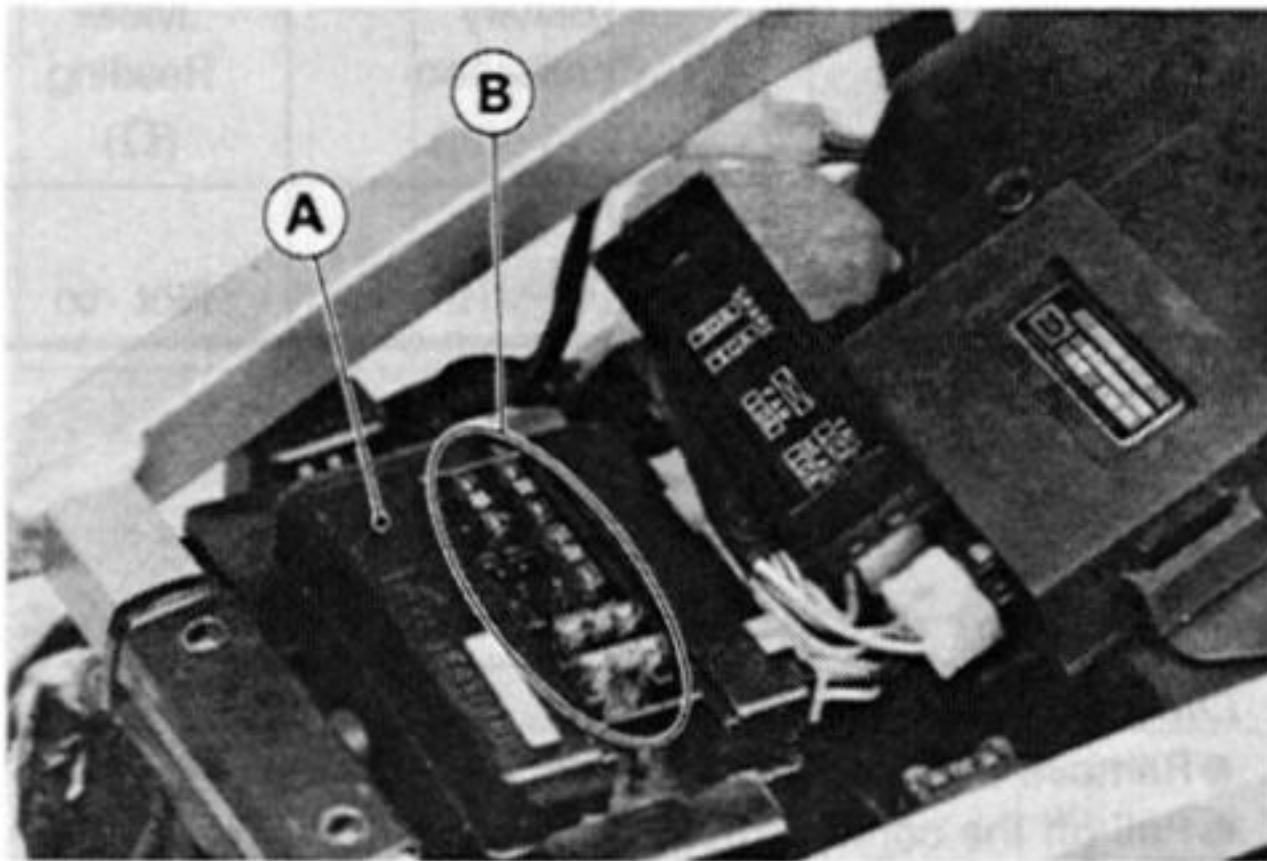

A. Junction Box
B. Fuses

C. Main Fuse

Fuse Installation

- ★ If a fuse fails during operation, inspect the electrical system to determine the cause, and then replace it with a new fuse of proper amperage.

Fuse Inspection

- Remove the fuse (see Fuse Removal).
- Inspect the fuse element.
- ★ If it is blown out, replace the fuse. Before replacing a blown fuse, always check the amperage in the affected circuit. If the amperage is equal to or greater than the fuse rating, check the wiring and related components for a short circuit.

CAUTION

When replacing a fuse, be sure the new fuse matches the specified fuse rating for that circuit. Installation of a fuse with a higher rating may cause damage to wiring and components.

Fuse

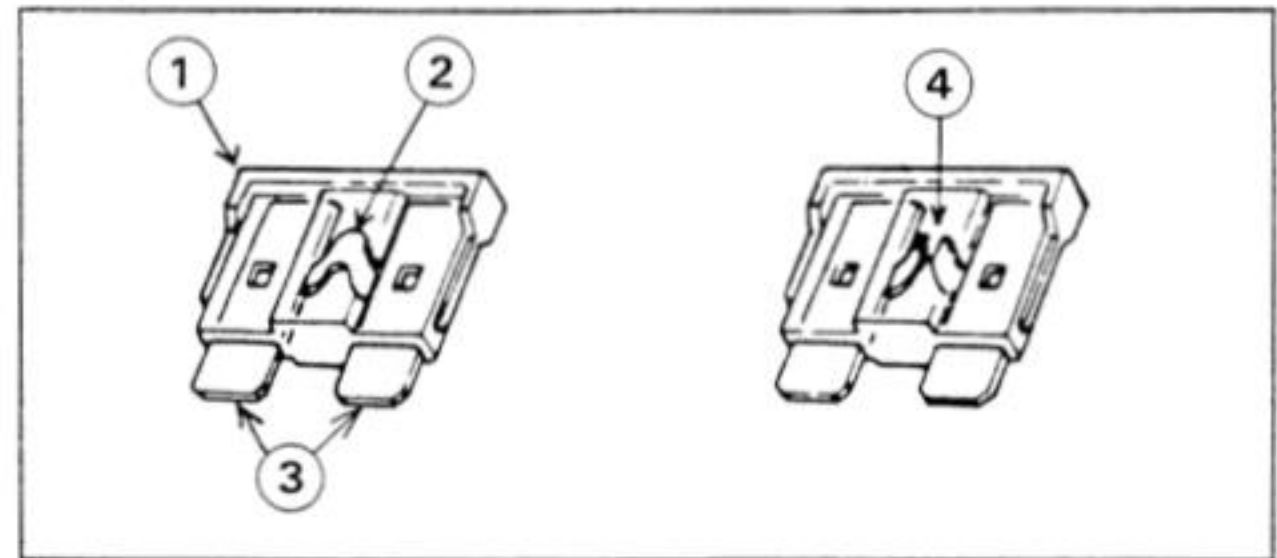

- 1. Housing
- 2. Fuse Element
- 3. Terminals
- 4. Blown Element

Junction Box Fuse Circuit Inspection

- Remove the junction box (see Fuse Removal).
- Pull off the connectors from the junction box.
- Make sure all connector terminals are clean and tight, and none of them have been bent.
- ★ Clean the dirty terminals, and straighten slightly-bent terminals.
- Check conductivity of the numbered terminals with the hand tester (special tool).
- ★ If the tester dose not read as specified, replace the junction box.

Fuse Circuit Inspection (ZX400-L1 ~ L4)

Meter Connection	Meter Reading (Ω)
1 - 2	0
*1 - 3B	0
6 - 7	0
6 - 17	0
1 - 7	∞
8 - 17	∞

* : U.K. Model

15-36 ELECTRICAL SYSTEM

Fuse Circuit Inspection (ZX400-L5)

Meter Connection	Meter Reading (Ω)
1 - 1A	0
1 - 2	0
3A - 4	0
6 - 5	0
6 - 10	0
6 - 7	0
6 - 17	0
1A - 8	∞
2 - 8	∞
3A - 8	∞
6 - 2	∞
6 - 3A	∞
17 - 3A	∞

Starter Circuit

- Remove the junction box (see Fuse Removal).
- Check conductivity of the following numbered terminal by connecting the hand tester (special tool) and one 12 V battery to the junction box as shown.
- ★ If the relay does not work as specified, replace the junction box.

Relay Circuit Inspection (ZX400-L1 ~ L4)

(with the battery disconnected)

Meter Connection	Meter Reading
11 - 13	∞
12 - 13	∞

(with the battery connected)

Meter Connection	Battery Connection		Meter Reading (Ω)
	(+)	(-)	
11 - 13	11	12	0

Relay Circuit Inspection (ZX400-L5)

(with the battery disconnected)

Meter Connection	Meter Reading
9 - 11	∞
12 - 13	∞
(+) (-) 13 - 11	∞

- (+): Apply positive lead.
- (-): Apply negative lead.

(with the battery connected)

Meter Connection	Battery Connection		Meter Reading (Ω)
	(+)	(-)	
(+) (-) 13 - 11	11	12	Not ∞

- (+): Apply positive lead.
- (-): Apply negative lead.

Diode Circuit Inspection

- Remove the junction box from the motorcycle.
- Pull off the connectors from the junction box.
- Check conductivity of the following pair of terminals.

Terminals for Diode Circuit Inspection

14-12, 14-15, 14-16 (ZX400-L1 ~ L4)
14-12, 14-15, 14-16, 11-12 (ZX400-L5)

- ★ The resistance should be low in one direction and more than ten times as much in the other direction. If any diode shows low or high in both directions, the diode is defective and the junction box must be replaced.

NOTE

- The actual meter reading varies with the meter used and the individual diodes, but, generally speaking, the lower reading should be from zero to one half the scale.

Junction Box Internal Circuit (U.K. Model: ZX400-L1 ~ L4):

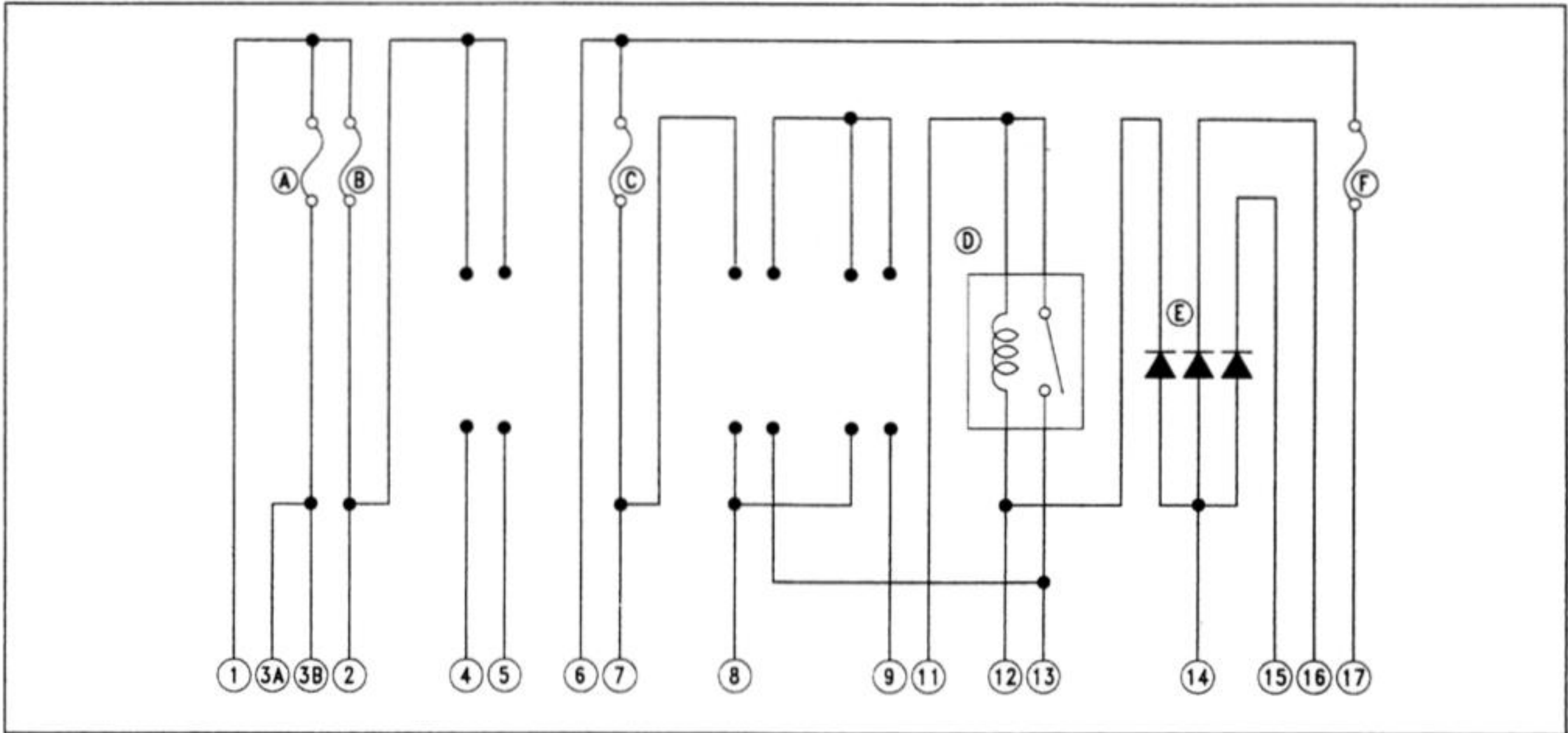

Junction Box Internal Circuit (other than U.K. Model: ZX400-L1 ~ L4):

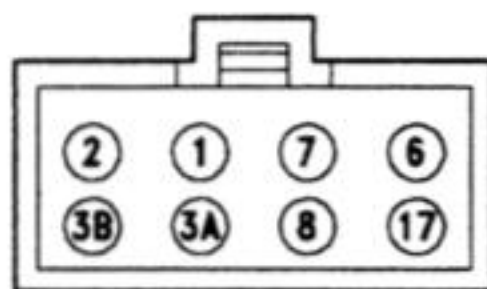
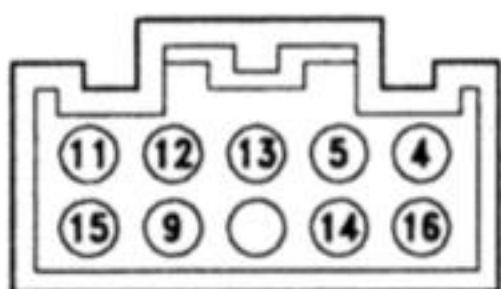
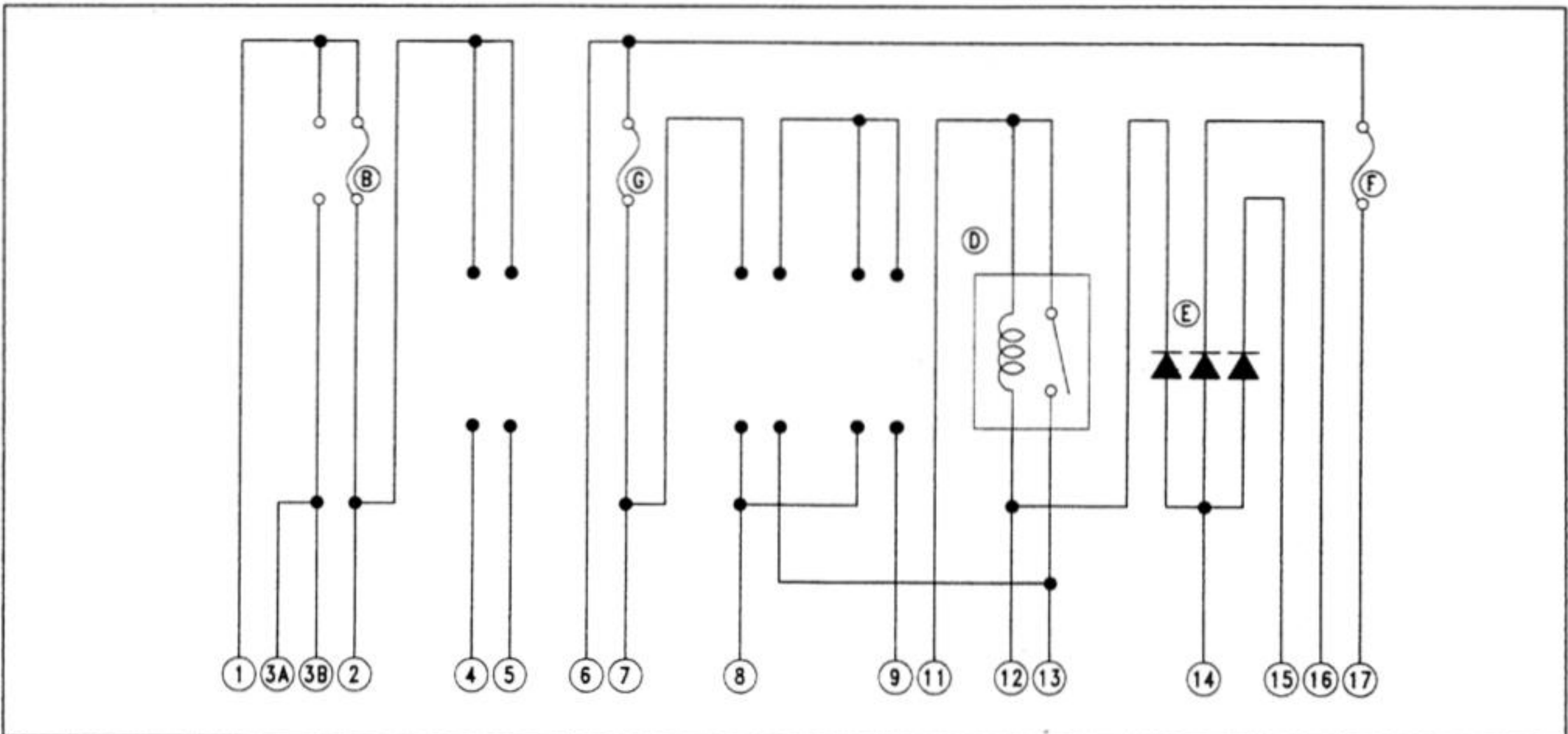

- A. 15 A High Beam Headlight Fuse
- B. 10A Fan Fuse
- C. 10A Low Beam Headlight Fuse
- D. Horn Fuse 10A

- E. Diodes
- F. 10A Taillight Fuse
- G. 10A Headlight Fuse

15-38 ELECTRICAL SYSTEM

Junction Box Internal Circuit (ZX400-L5):

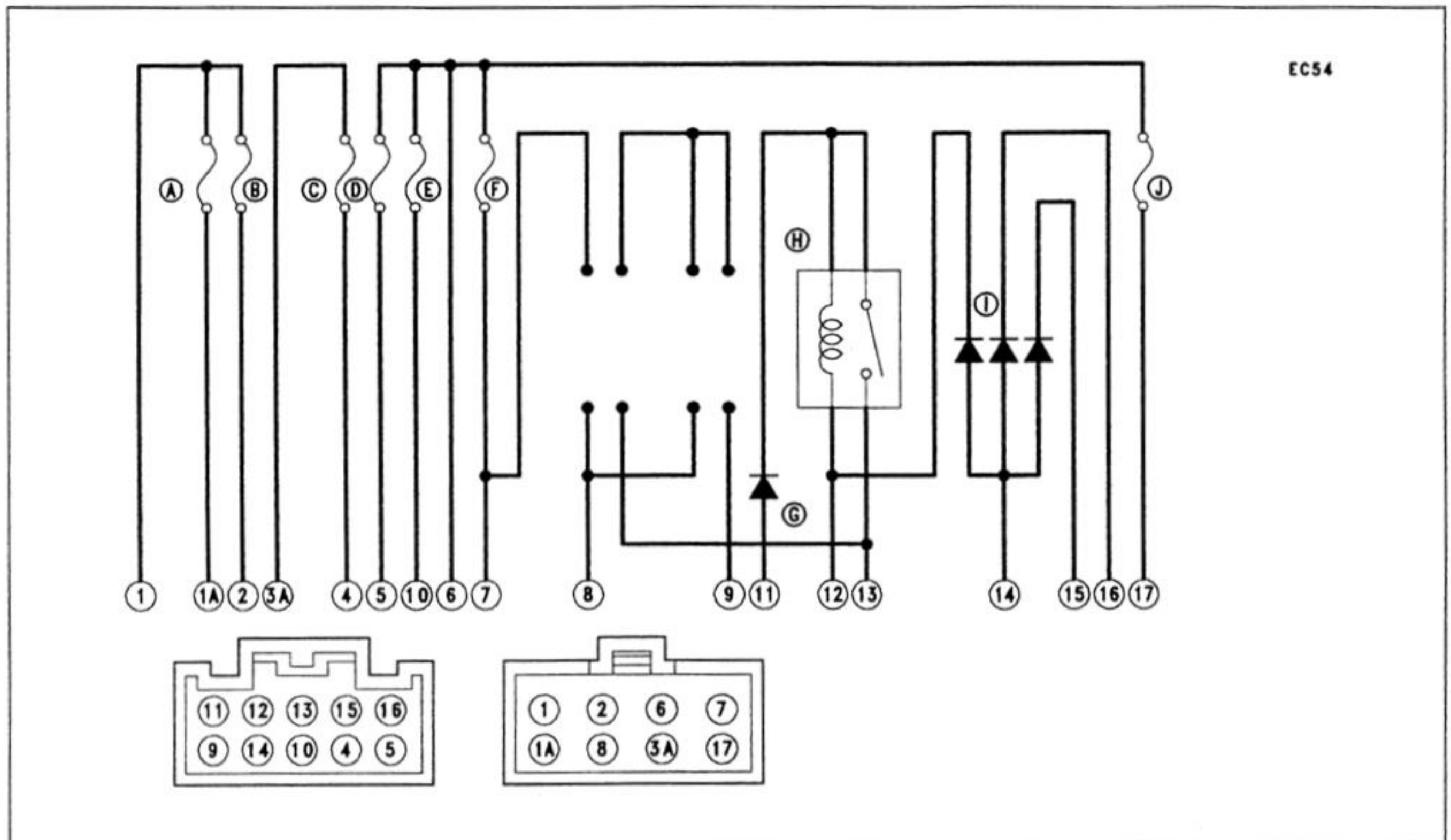

A. Accessory Fuse 10A

B. Fan Fuse 10A

C. Turn Signal Relay Fuse 10A

D. Horn Fuse 10A

E. Ignition Fuse 10A

F. Headlight Fuse 10A

G. Starter Diode

H. Starter Circuit Relay

I. Interlock Diodes

J. Taillight Fuse 10A

Electrical Wiring

Wiring Inspection

- Visually inspect the wiring for signs of burning, fraying, etc.
- ★ If any wiring is poor, replace the damaged wiring.
- Pull each connector apart and inspect it for corrosion, dirt, and damage.
- ★ If the connector is corroded or dirty, clean it carefully. If it is damaged, replace it.
- Check the wiring for continuity.
- Use the wiring diagram to find the ends of the lead which is suspected of being a problem.
- Connect an ohmmeter between the ends of the leads.
- Set the meter to the x 1 Ω range, and read the meter.
- ★ If the meter does not read 0 Ω , the lead is defective. Replace the lead or the wiring loom if necessary.

Appendix

Table of Contents

Additional Considerations for Racing	(16-2)
Carburetor	(16-2)
Spark Plug	(16-2)
Spark Plug Inspection	(16-3)
Troubleshooting Guide	(16-4)
General Lubrication	(16-7)
Lubrication	(16-7)
Nut, Bolt, and Fastener Tightness	(16-8)
Tightness Inspection	(16-8)
Unit Conversion Table	(16-9)

() : Refer to Base Manual

Supplement - 1999 Model

Table of Contents

Foreword	17-2
General Information	17-3
General Specifications	17-4
Periodic Maintenance Chart	17-6
Torque and Locking Agent	17-7
Fuel System	17-7
Specifications	17-7
Wheels/ Tires	17-8
Specifications	17-8
Suspension	17-8
Specifications	17-8
Frame	17-9
Exploded View	17-9
Electrical System	17-11
Specifications	17-11
Wiring Diagram	17-12

How to Use this Manual

This "Supplement-1999 Model " designed to be used in conjunction with the front part of this manual (up to 16 - 1) and /or Base Manual ZX400H Service Manual –Part No. 99924-1137-01.

The specifications and maintenance procedures described in this chapter are only those that are unique to the ZX400-L9 model.

Complete and proper servicing of the ZX400-L9 model therefore requires mechanics to read both this chapter and the front of this manual.

General Information

General Specifications

Item	ZX400-L9
Dimensions:	
Overall length	1 995 mm
Overall width	700 mm
Overall height	1 080 mm
Wheelbase	1 385 mm
Road clearance	120 mm
Seat height	790 mm (SG, KR) 760 mm
Dry weight	162 kg, (SG, KR) 159 kg
Curb weight:	95 kg, (SG, KR) 93 kg
Front	
Rear	93 kg, (SG, KR) 92 kg
Fuel tank capacity	16.0 L
Performance:	
Minimum turning radius	3.2 m
Engine:	
Type	4-stroke, DOHC, 4-cylinder
Cooling system	Liquid-cooled
Bore and stroke	57.0 × 39.0 mm
Displacement	398 mL
Compression ratio	12.1
Maximum horsepower	47.8 kW (65 PS) @ 13 000 r/min (rpm),
Maximum Torque	36.3 N-m (3.7 kg-m, 26.8 ft-lb) @ 12 000 r/min (rpm),
Carburetion system	Carburetor, Keihin CVK-D 32 × 4
Starting system	Electric starter
Ignition system	Battery and coil (transistorized)
Timing advance	Electronically advanced
Ignition timing	From 12.5° BTDC @ 1 200 r/min (rpm) to 45° BTDC @ 6 000 r/min (rpm),
Spark plug	NGK CR9EK or ND U27ETR
Cylinder numbering method	Left to right, 1-2-3-4
Firing order	1-2-4-3
Valve timing:	
Inlet:	Open 23° (BTDC)
	Close 65° (ABDC)
	Duration 268°
Exhaust:	Open 57.5° (BBDC)
	Close 27.5° (ATDC)
	Duration 265°
Lubrication system	Forced lubrication (wet sump with cooler)
Engine oil:	Grade SE, SF, or SG class
	Viscosity SAE 10W-40, 10W-50, 20W-40, or 20W-50
	Capacity 3.0 L
Drive Train:	
Primary reduction system:	
Type	Gear
Reduction ratio	2.195 (90/41)

Item	ZX400-L9	
Clutch type:	Wet multi disc	
Transmission:	Type	6-speed, constant mesh, return shift
	Gear ratios:	
	1st	2.846 (37/13)
	2nd	2.000 (38/19)
	3rd	1.578 (30/19)
	4th	1.318 (29/22)
	5th	1.200 (30/25)
	6th	1.111 (30/27)
Final drive system:	Type	Chain drive
	Reduction ratio	3.000 (45/15)
	Overall drive ratio	7.317 @Top gear
Frame:		
Type	Press, diamond	
Caster (rake angle)	23.5°	
Trail	82 mm	
Front tire:	Type	TUBELESS
	Size	120/60-R17 55V
Rear tire:	Type	TUBELESS
	Size	160/60-R17 69V
Front suspension:	Type	Telescopic fork
	Wheel travel	120 mm
Rear suspension:	Type	Swingarm (uni-trak)
	Wheel travel	120 mm
Brake type:	Front	Dual disc
	Rear	Single disc
Electrical Equipment:		
Battery	12 V 8 Ah	
Headlight:	Type	Semi-sealed beam
	Bulb	Quartz-halogen 12 V 60/55 W, (UK, SG) 12 V 60/35 W × 2
Tail/brake light:	12 V 5/21 W × 2	
Alternator:	Type	Three-phase AC
	Rated output	23 A @10 000 r/min (rpm), 14 V,

Specifications are subject to change without notice, and may not apply to every country.

(SG) : Singapore Model

(UK) : U.K. Model

(KR) : Korea Model

17-6 SUPPLEMENT - 1999 MODEL

The scheduled maintenance must be done in accordance with this chart to keep the motorcycle in good running condition. **The initial maintenance is vitally important and must not be neglected.**

OPERATION	FREQUENCY	*ODOMETER READING							
		Whichever comes first ↓ Every	1 000 km (600 mile)	60 000 km (40 000 mile)	12 000 km (7 500 mile)	18 000 km (12 000 mile)	24 000 km (15 000 mile)	30 000 km (20 000 mile)	36 000 km (24 000 mile)
Spark plug – clean and gap †			•	•	•	•	•	•	
Valve clearance – check †				•		•		•	
Air cleaner element – clean † #				•		•		•	
Throttle grip play – check †		•		•		•		•	
Idle speed – check †		•		•		•		•	
Idle speed – adjust		•		•		•		•	
Carburetor synchronization – check †				•		•		•	
Engine oil – change #	6 months	•	•	•	•	•	•	•	
Oil filter – replace		•		•		•		•	
Radiator hoses, connections – check †		•							
Coolant – change	2 years					•			
Clutch – adjust		•	•	•	•	•	•	•	
Drive chain wear – check † #			•	•	•	•	•	•	
Drive chain – lubricate #	600 km								
Drive chain slack – check † #	1 000 km								
Brake lining or pad wear – check † #			•	•	•	•	•	•	
Brake fluid level – check †	month	•	•	•	•	•	•	•	
Brake fluid – change	2 years					•			
Brake master cylinder cup and dust seal – replace	4 years								
Caliper piston seal and dust seal – replace	4 years								
Brake light switch – check †		•	•	•	•	•	•	•	
Steering – check †		•	•	•	•	•	•	•	
Steering stem bearing – lubricate	2 years					•			
Front fork oil – change	2 years					•			
Rear shock absorber oil leak – check †				•		•		•	
Front fork oil leak – check †				•		•		•	
Tire wear – check †			•	•	•	•	•	•	
Swingarm pivot, uni-trak linkage – lubricate				•		•		•	
General lubrication – perform				•		•		•	
Nut, bolt, and fastener tightness – check †		•		•		•		•	
Coolant filter – clean	year								

: Service more frequently when operating in severe conditions, dusty, wet, muddy, high speed, or frequent starting/stopping.

* : For higher odometer readings, repeat at the frequency interval established here.

† : Replace, add, adjust, clean, or torque if necessary.

Torque and Locking Agent

Fastener	Torque			Remarks
	N-m	kg-m	ft-lb	
Brakes :				
Bleed valves	7.8	0.80	69 in-lb	
Caliper Mounting Bolts (Front)	32	3.3	24	
Caliper Assembly Bolts: Front	21	2.1	15	
Rear	32	3.3	24	
Pad Spring Screws	2.9	0.30	26 in-lb	
Disc Mounting Bolt: Front	27	2.8	20	
Rear	23	2.3	17	
Brake Hose Banjo Bolts	25	2.5	18	
Brake Lever Pivot Bolt	1.0	0.10	9 in-lb	
Brake Lever Pivot Locknut	5.9	0.60	52 in-lb	
Front Brake Light Switch Mounting Screw	1.2	0.12	10 in-lb	
Brake Pedal Mounting Bolt	34	3.5	25	
Rear Master Cylinder Rod Locknut	18	1.8	13	
Caliper Mounting Bolts (Rear)	25	2.5	18	
Rear Master Cylinder Mounting Bolts	23	2.3	17	
Torque Link Bolt	25	2.5	18	
Torque Link Nut	25	2.5	18	

Fuel System

Specifications

Item	Standard
Throttle Grip Free Play:	2 ~ 3 mm
Choke Cable Free Play:	2 ~ 3 mm
Idle Speed :	1300 ± 50r/min (rpm), (IT, UK, NL, GR) 1200 ± 50r/min (rpm)
Carburetor Specifications:	
Make/ type	Keihin/ CVK-D32
Synchronization vacuum	2.7 kPa (2 cm Hg) or less difference between two cylinders
Main jet Standard	#95
Option	#90, 92, 98, 100
Main air jet	#100
Needle jet	#6
Jet needle mark	N 77W, (IT, UK, NL, GR) N 77S
Pilot jet (slow jet)	#35
Pilot air jet	#120, (IT, UK, NL, GR) #110
Pilot screw	1 3/4, (IT, UK, NL, GR) 1 5/8
Starter jet	#45
Service fuel level	8 ± 1 mm below the mark
Float height	11 ± 2 mm
Air Cleaner:	
Air cleaner element oil: Grade	SE or SF class
Viscosity	SAE 30

(IT): Italia Model
(GR): Greece Model

(UK): U.K. Model

(NL): Netherlands Model

17-8 SUPPLEMENT - 1999 MODEL

Wheels/Tires

Specifications

Item	Standard	Service Limit
Wheels:		
Rim runout: Axial	---	TIR 0.5 mm
Radial	---	TIR 0.8 mm
Axle runout/ 100 mm	TIR 0.5 mm or less	TIR 0.2 mm
Tires:		
Front: Type	Tubeless	---
Size	120/60 R17 55V	
Make	BRIDGESTONE, CYROX-7	
Rear: Type	Tubeless	---
Size	160/60 R17 69V	
Make	BRIDGESTONE, CYROX-20	
Air pressure (when cold):		
Front:	Up to 185 kg (408 lb) load 225 kPa (2.25 kg/ cm ² , 32 psi)	---
Rear:	Up to 185 kg (408 lb) load 250 kPa (2.50 kg/ cm ² , 36 psi)	---
Tread depth:		
Front:	3.4 mm	1 mm
Rear:	5.8 mm under 130 km/h (80mph) over 130 km/h (80mph)	2 mm 3 mm

Suspension

Specifications

Item	Standard	Service Limit
Front Fork:		
Rebound damping setting	6 clicks counterclockwise (front the seated position adjuster turned fully clockwise)	(adjustable range) 12 clicks
Spring preload setting	6 th mark from the top	(adjustable range) 7 makes
Fork oil:		
Viscosity	SAE 5W	---
Amount (per side)	424 ± 2.5 mL	---
Oil level (fully compressed, with spring)	85 ± 8 mm below from top of outer tube	---
Fork spring free length	325.1 mm	319 mm
Rear Shock Absorber:		
Rebound damping setting	No. 2 of 4 position, (SG) No. 1 of 4 position	---
Spring preload setting	Spring free length minus 6.5 mm	Spring free length minus 6.5 mm to 24.5 mm
Gas pressure	980 kPa (10 kg/ cm ² , 142 psi) Non-adjustable	---

(SG): Singapore Model

Frame

Exploded View

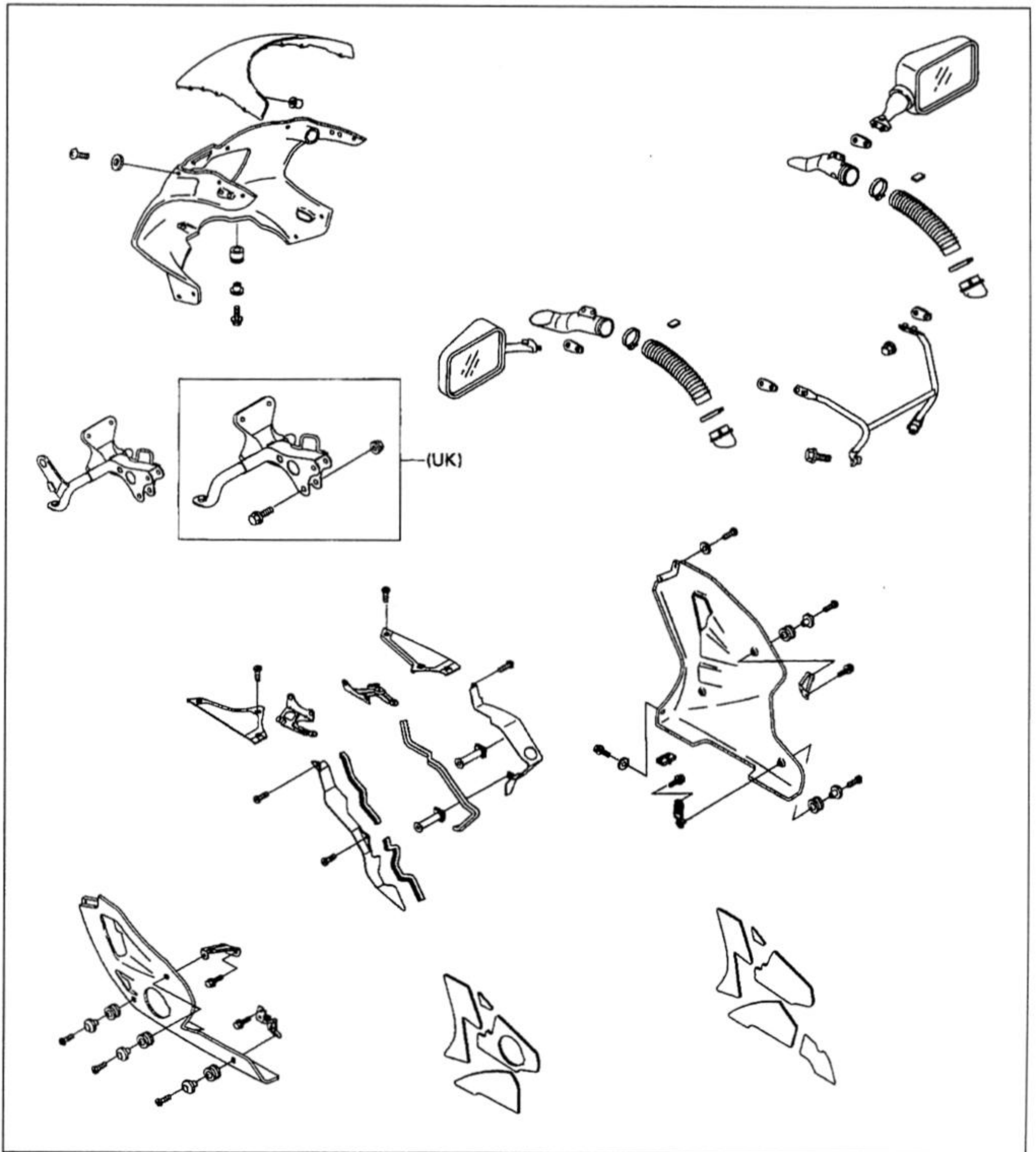

UK : U.K. Model

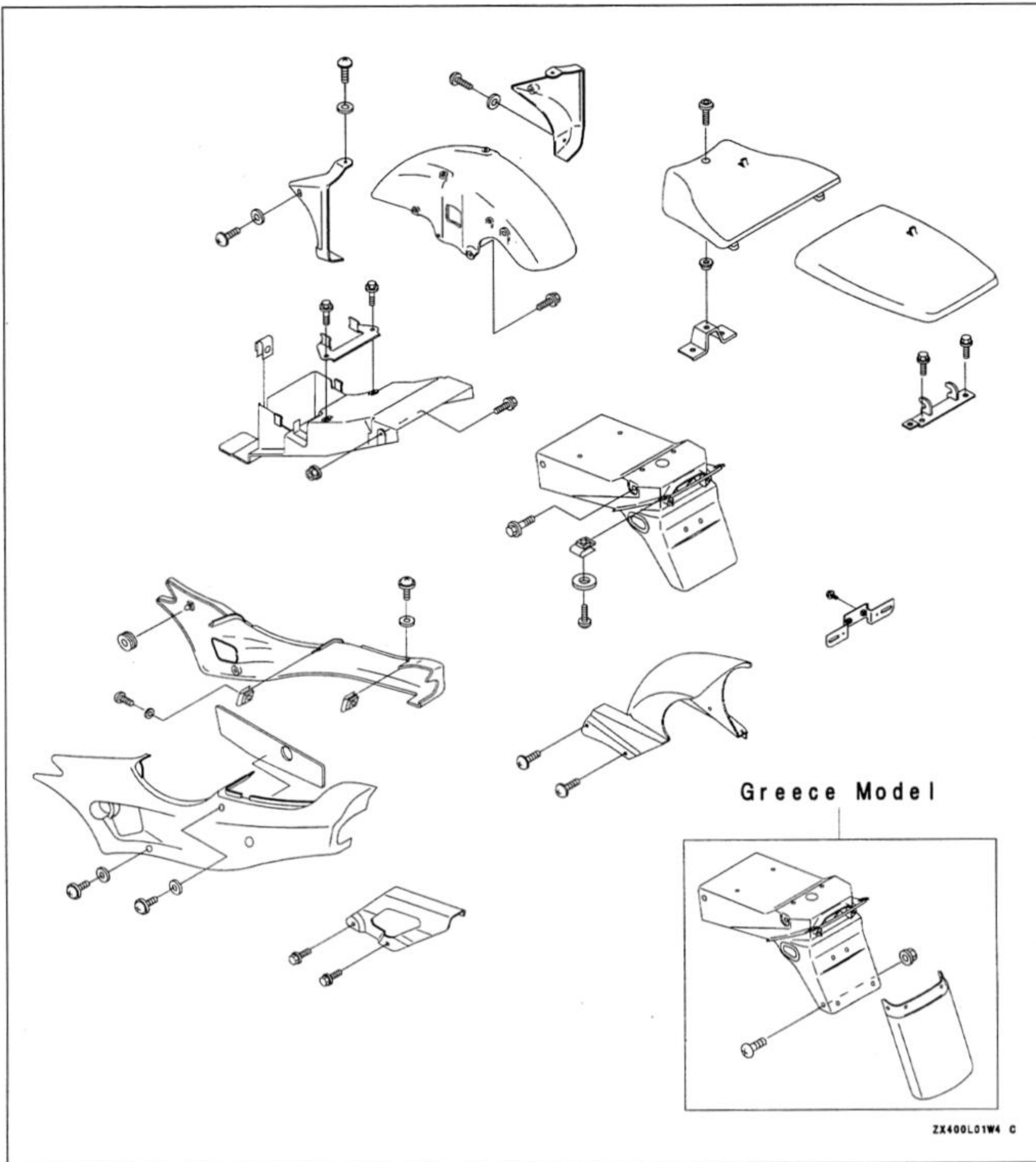

Electrical System**Specifications**

Item	Standard	Service Limit
Ignition System: Spark Plug : Standard ; Option ;	NGK CR9EK or ND U27 ETR NGK CR8EK or ND U24 ETR	

17-12 SUPPLEMENT - 1999 MODEL

Wiring Diagram (Singapore Model)

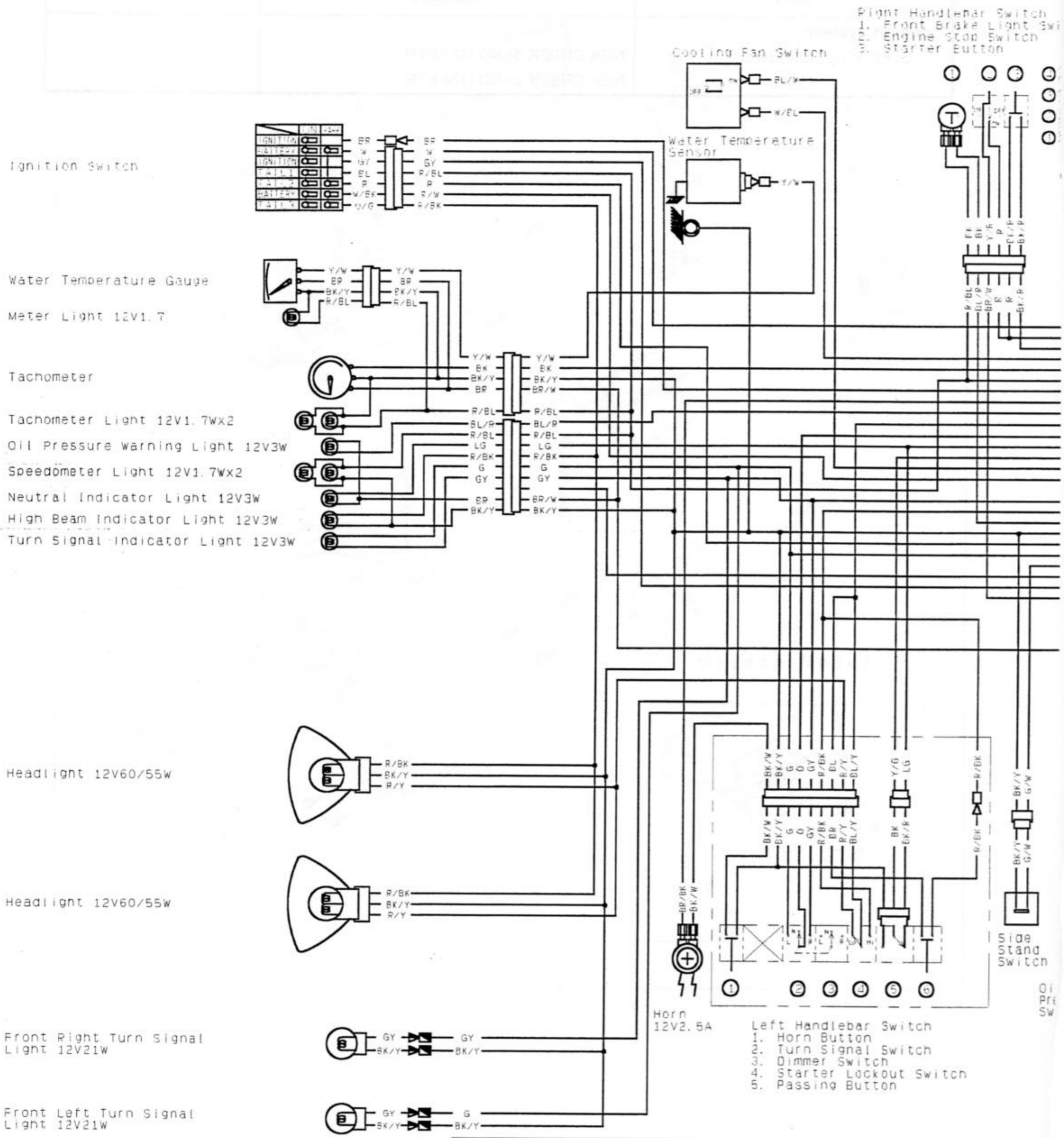

Horn Button		Turn Signal Switch			Dimmer Switch			Starter Lockout Switch		Passing					
Color	BK/W	BK/Y	Color	G	O	GY	Color	R/Y	BL/Y	R/BK	Color	BK/Y	BK	BK/R	Color
			R				HI				Clutch Lever				
Push			OFF (Push)				LO				Released				Push
			L								Pulled in				

LA, LB (Austria, Dutch, French, Korea Models)

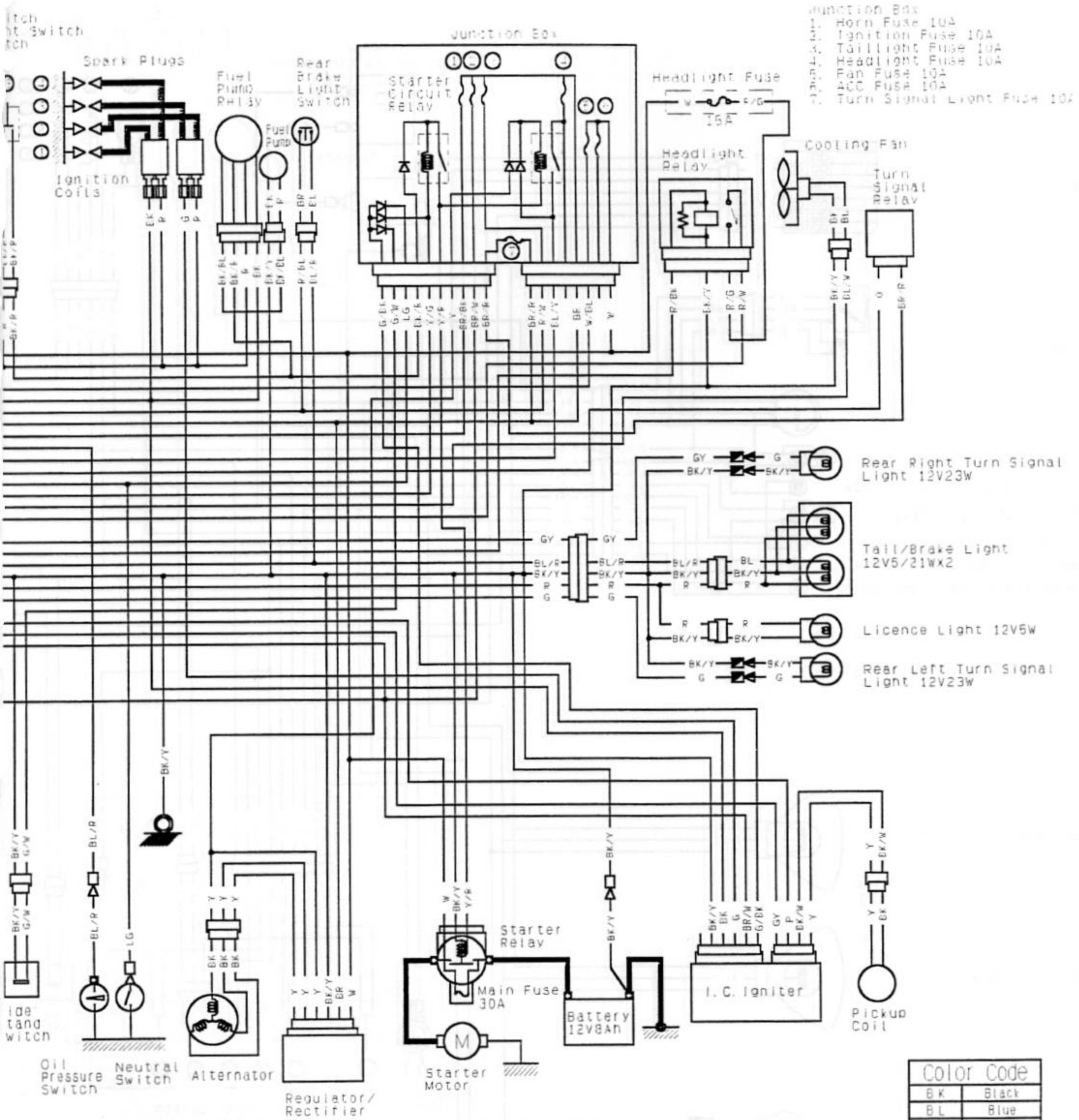

- Junction Box
- 1. Horn Fuse 10A
 - 2. Ignition Fuse 10A
 - 3. Taillight Fuse 10A
 - 4. Headlight Fuse 10A
 - 5. Fan Fuse 10A
 - 6. ACC Fuse 10A
 - 7. Turn Signal Light Fuse 10A

Passing Button	Color	BR	R/BK
Push			

IGNITION SWITCH CONNECTIONS							
	Ignition	Battery	Ignition	Tail1	Tail2	Battery	Tail3
Color	BR	W	GY	BL	R	W/BK	O/G
OFF. LOCK							
ON	—————						
P(PARK)							

RIGHT HANDLEBAR SWITCH CONNECTIONS								
	Front Brake Light Switch		Engine Stop Switch		Starter Button			
Color	BK	BK	Color	Y/R	R	Color	BK/R	BK/R
Brake Lever			OFF					
Pulled In	—————					Push		
			RUN					

Color Code	
BK	Black
BL	Blue
BR	Brown
CH	Chocolate
DG	Dark Green
G	Green
GY	Gray
LB	Light Blue
LG	Light Green
O	Orange
P	Pink
PU	Purple
R	Red
W	White
Y	Yellow

17-14 SUPPLEMENT - 1999 MODEL

ZX400-L5, L6, L7, L8 (Austria, Dutch, French, Korea Models)

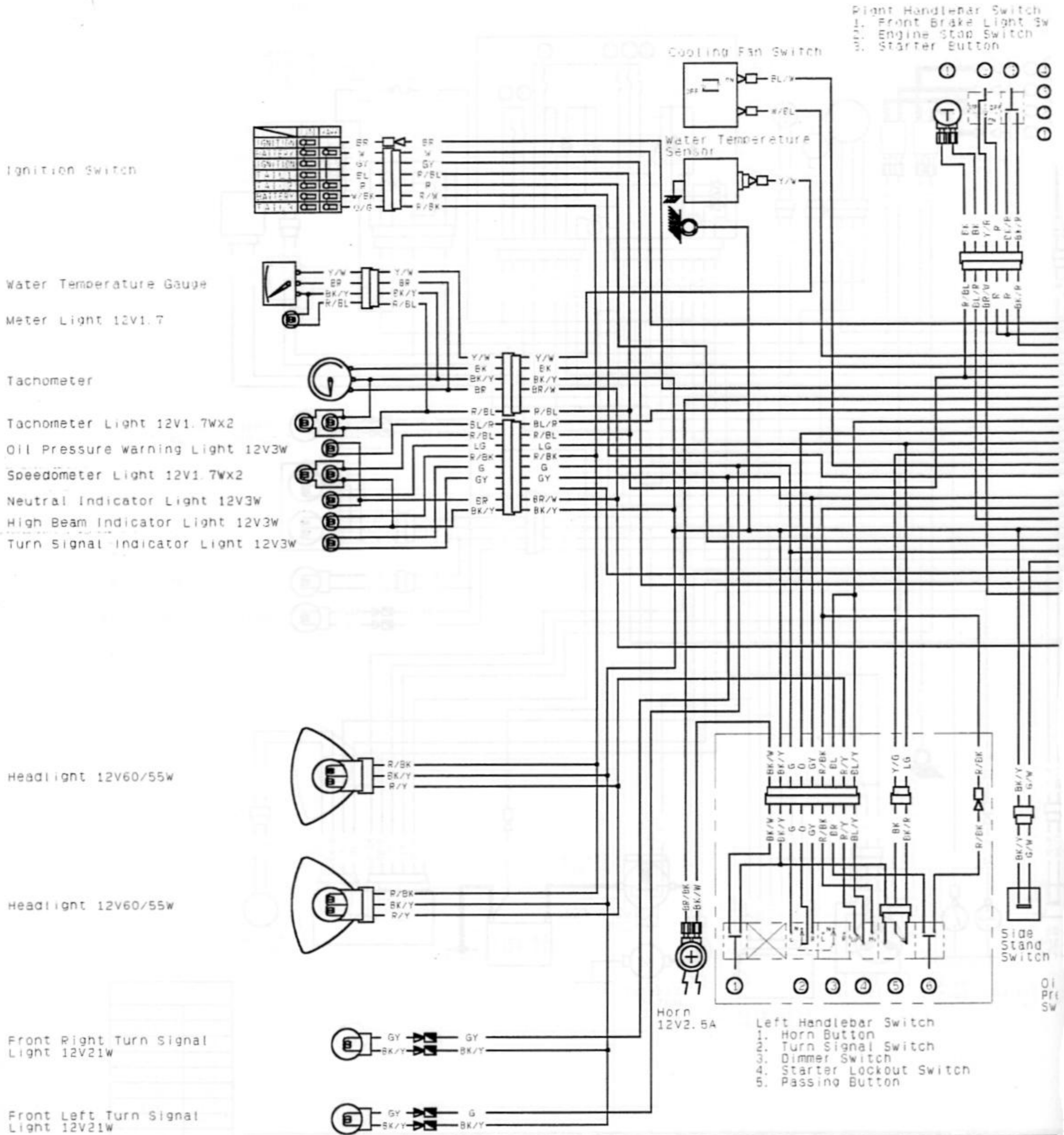

Right Handlebar Switch
 1. Front Brake Light Sw
 2. Engine Stop Switch
 3. Starter Button

Left Handlebar Switch
 1. Horn Button
 2. Turn Signal Switch
 3. Dimmer Switch
 4. Starter Lockout Switch
 5. Passing Button

LEFT HANDLEBAR SWITCH CONNECTIONS

Horn Button	Turn Signal Switch	Dimmer Switch	Starter Lockout Switch	Passing
Color BK/W BK/Y	Color G O GY	Color R/Y BL/Y R/BK	Color BK/Y BK BK/R	Color
Push	R OFF(Push) L	HI LO	Clutch Lever Released Pushed in	Push

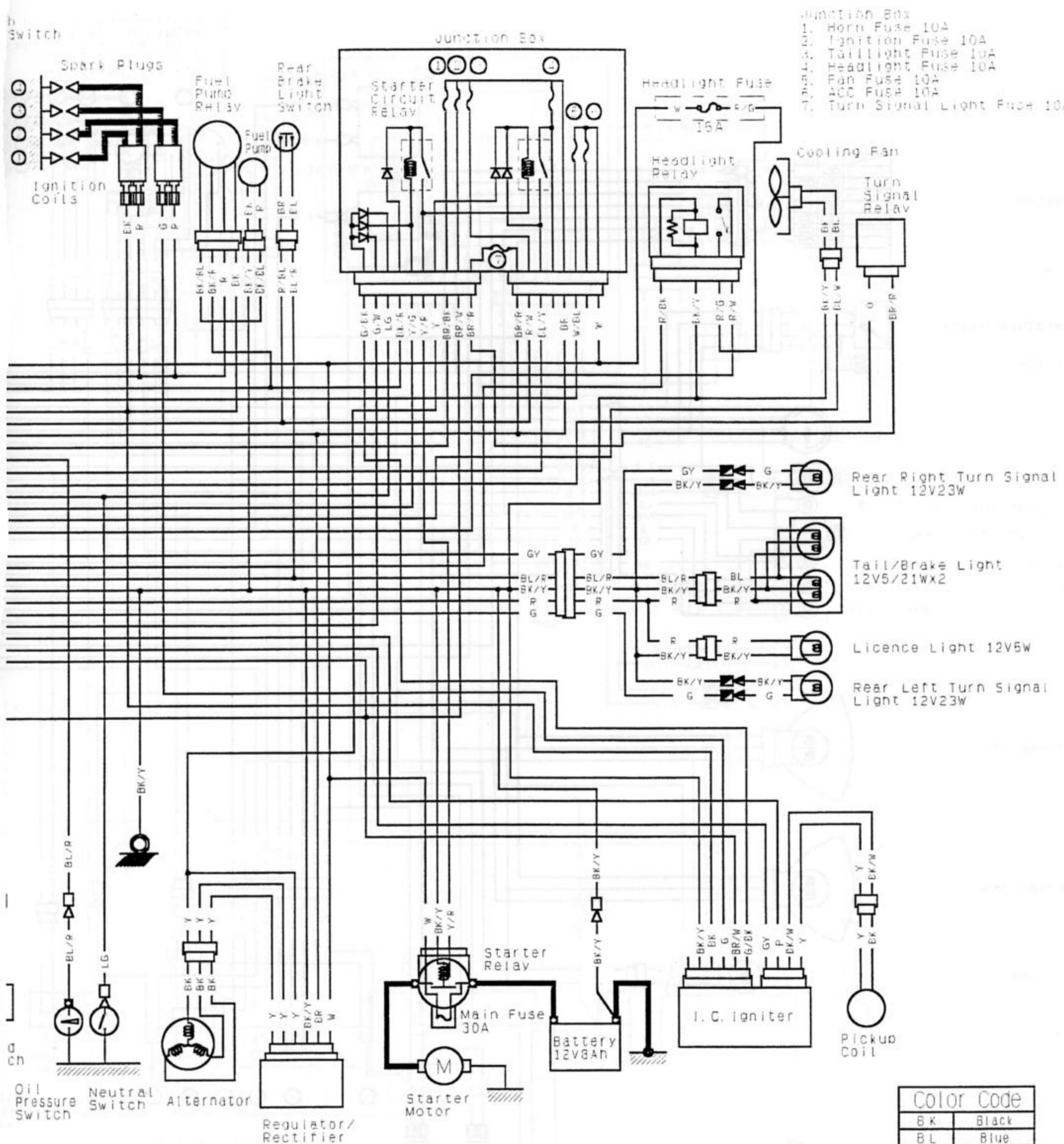

- Junction Box
1. Horn Fuse 10A
 2. Ignition Fuse 10A
 3. Taillight Fuse 10A
 4. Headlight Fuse 10A
 5. Fan Fuse 10A
 6. ACC Fuse 10A
 7. Turn Signal Light Fuse 10A

Color Code	
BK	Black
BL	Blue
BR	Brown
CH	Chocolate
DG	Dark Green
G	Green
GY	Gray
LB	Light Blue
LG	Light Green
O	Orange
P	Pink
PU	Purple
R	Red
W	White
Y	Yellow

Line Button	Color
OFF. LOCK	BR R/BK
ON	BR R/BK
P(PARK)	BR R/BK

IGNITION SWITCH CONNECTIONS						
	Ignition	Battery	Ignition	Tail1	Tail2	Battery
	Color	BR	W	GY	BL	R
OFF. LOCK		●	●	●	●	●
ON		●	●	●	●	●
P(PARK)		●	●	●	●	●

RIGHT HANDLEBAR SWITCH CONNECTIONS					
	Front Brake Light Switch	Engine Stop Switch	Starter Button		
	Color	BK	BK	Color	Y/R
Brake Lever		●	●	Color <td>R</td>	R
Pulled In		●	●	Color <td>BK/R</td>	BK/R
				Color <td>BK/R</td>	BK/R
				Color <td>BK/R</td>	BK/R

ZX400-L9 Wiring Diagram (U.K. Model)

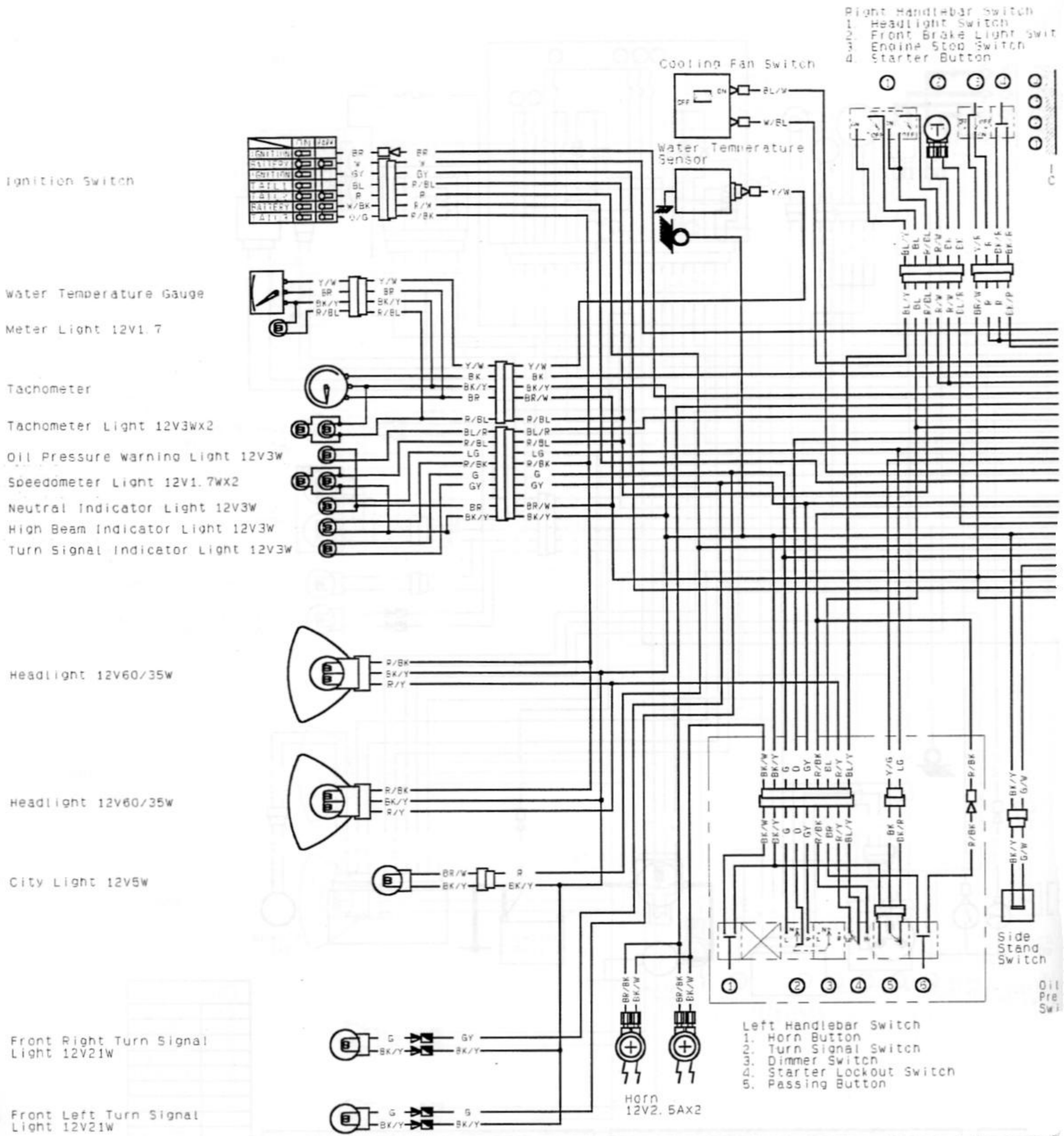

LEFT HANDLEBAR SWITCH CONNECTIONS									
Horn Button	Turn Signal Switch	Dimmer Switch	Starter Lockout Switch	Passing Button					
Color	BK/W BK/Y	Color	G O GY	Color	R/Y BL/YR/BK	Color	BK/Y BK BK/R	Color	BR R/BK
Push	OFF (Push)	HI	Clutch Level	Push					
	L	LO	Released	Push					
			Pulled in						

IGNI	
Color	BR
OFF. LOCK	OFF. LOCK
ON	ON
P (PARK)	P (PARK)

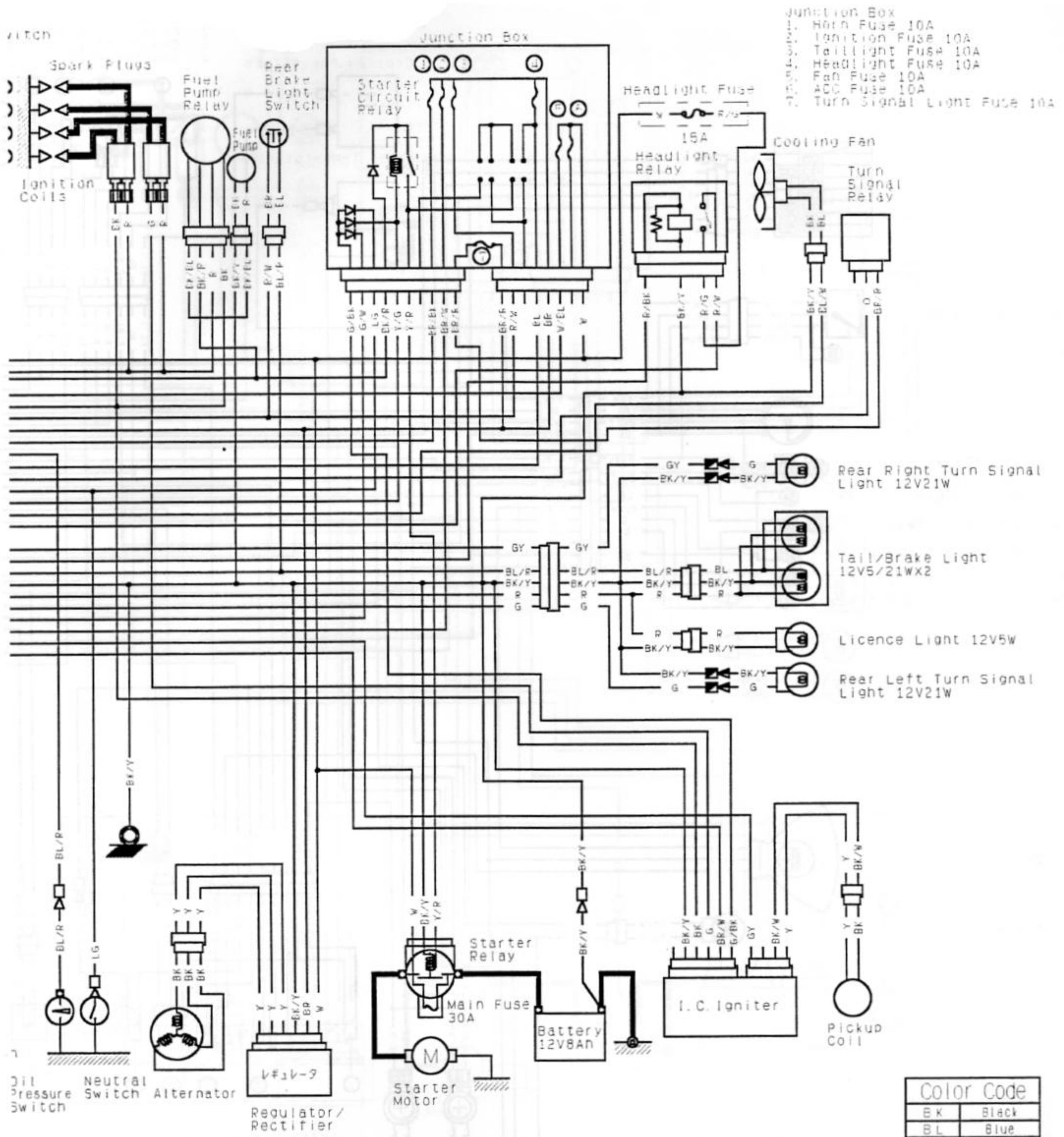

- Junction Box
1. Horn Fuse 10A
 2. Ignition Fuse 10A
 3. Taillight Fuse 10A
 4. Headlight Fuse 10A
 5. Fan Fuse 10A
 6. ACC Fuse 10A
 7. Turn Signal Light Fuse 10A

IGNITION SWITCH CONNECTIONS						
Ignition	Battery	Ignition	Tail1	Tail2	Battery	Tail3
BR	W	GY	BL	R	W/BK	O/G

RIGHT HANDLEBAR SWITCH CONNECTIONS							
Headlight Switch		Front Brake Light Switch		Engine Stop Switch		Starter Button	
Color	BL/Y	BL	R/BL	R/W	Color	BK	BK
OFF					Color <td>Y/R <td>R</td> </td>	Y/R <td>R</td>	R
					Color <td>BK/P</td> <td>BK/R</td>	BK/P	BK/R
					Color <td></td> <td></td>		
ON					Color <td></td> <td></td>		

Color Code	
BK	Black
BL	Blue
BR	Brown
CH	Chocolate
DG	Dark Green
G	Green
GY	Gray
LB	Light Blue
LG	Light Green
O	Orange
P	Pink
PU	Purple
R	Red
W	White
Y	Yellow

17-18 SUPPLEMENT - 1999 MODEL

ZX400-L9 Wiring Diagram (Austria, Dutch, German, German, Greece, Italy Models)

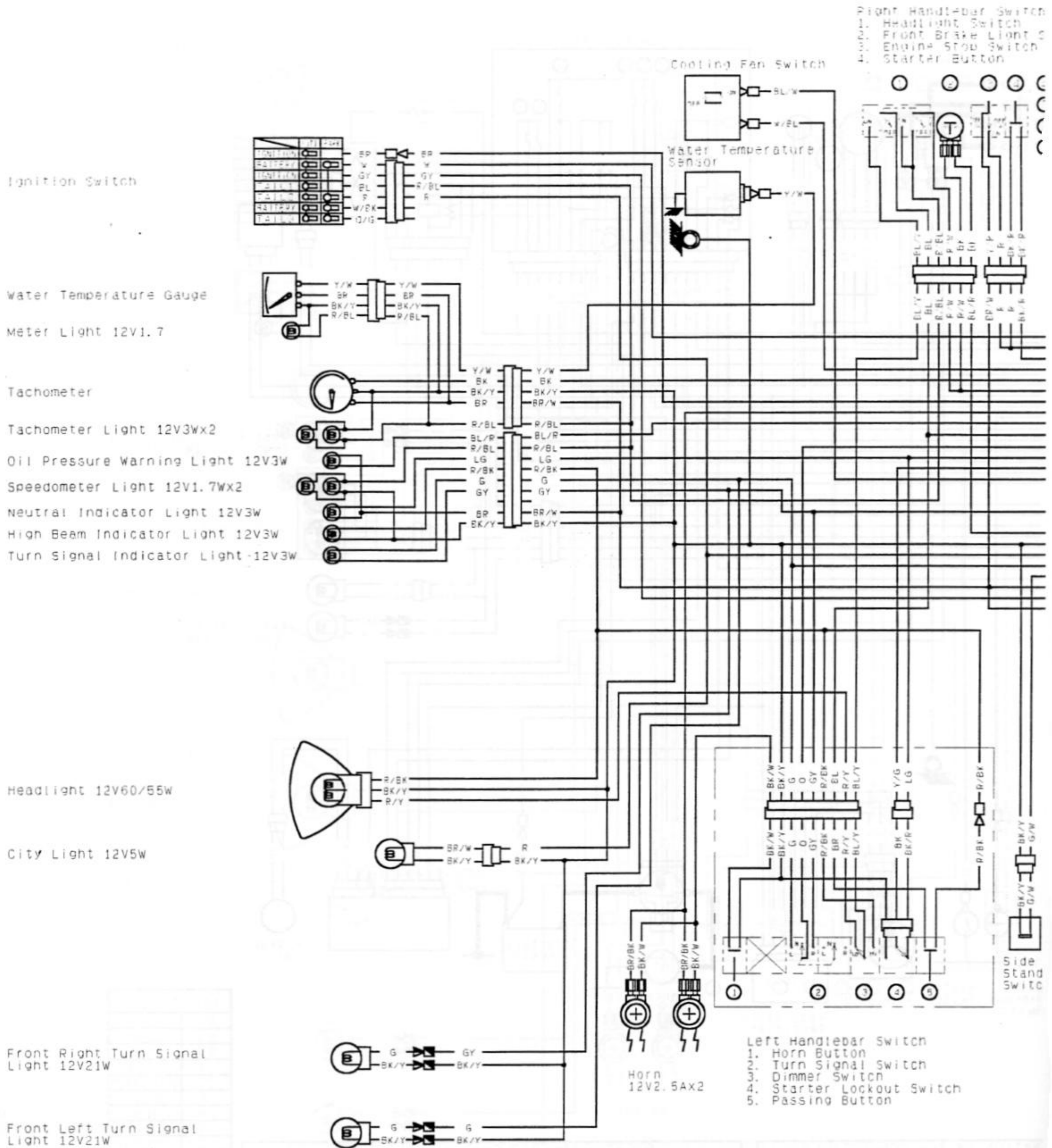

LEFT HANDLEBAR SWITCH CONNECTIONS

Horn Button		Turn Signal Switch		Dimmer Switch			Starter Lockout Switch			Passing Button	
Color	Wiring	Color	Wiring	Color	Wiring	Color	Wiring	Color	Wiring	Color	Wiring
	BR/BK	R	BK/Y	H	R/Y	LO	BL/YR/BK	clutch Lever	BK/Y	BK	BK/R
Push	—	OFF (Push)	—	—	—	Released	—	Released	—	Push	—
		L	—	LO	—	Pulled in	—	Pulled in	—	—	—

IGNITION SWITCH CONNECTIONS

Color	Wiring
Color	BR
OFF, LOCK	—
ON	—
P (PARK)	—

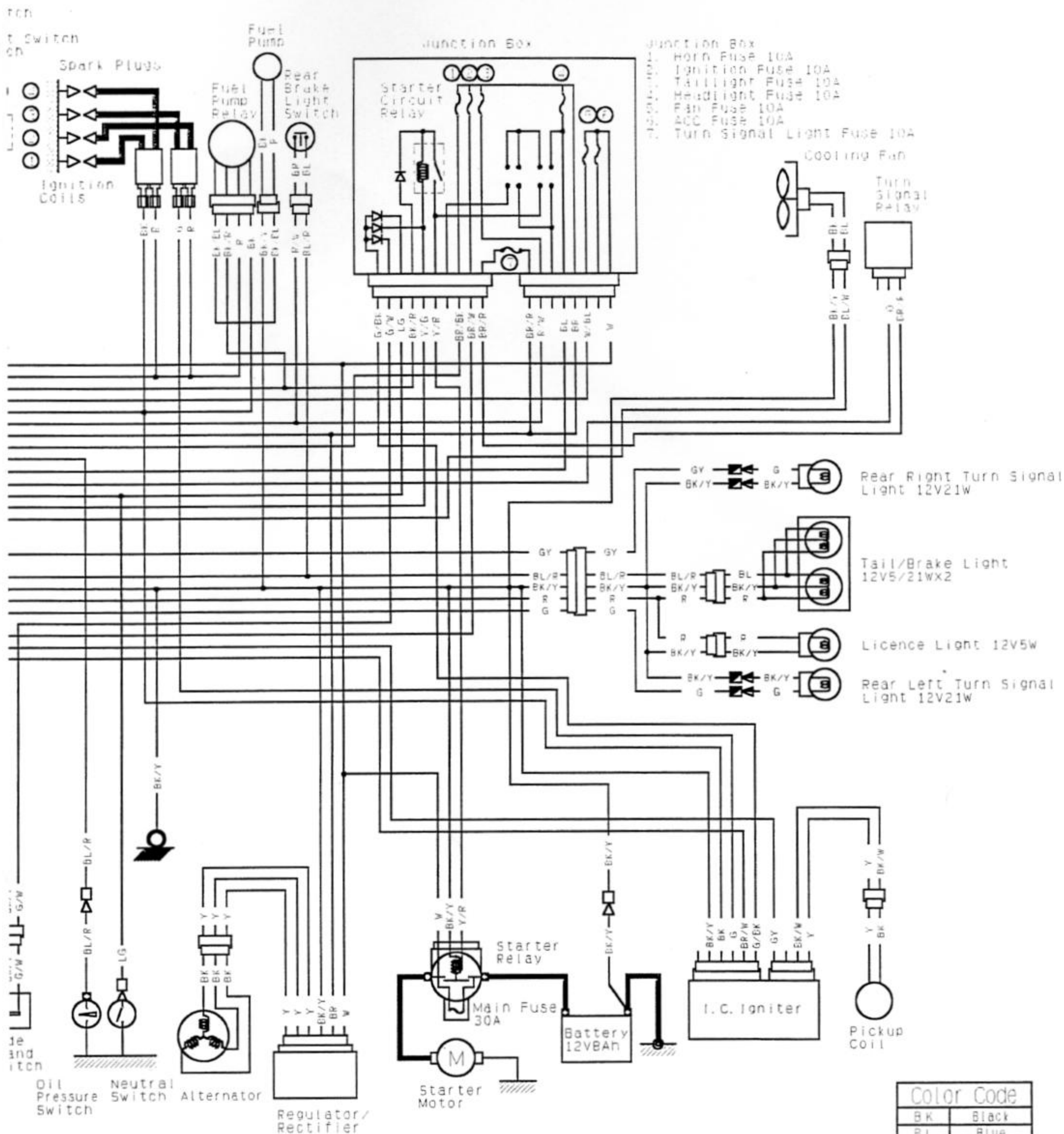

- JUNCTION BOX
- 1. Horn Fuse 10A
 - 2. Ignition Fuse 10A
 - 3. Taillight Fuse 10A
 - 4. Headlight Fuse 10A
 - 5. Park Fuse 10A
 - 6. ACC Fuse 10A
 - 7. Turn Signal Light Fuse 10A

Color Code	
BK	Black
BL	Blue
BR	Brown
CH	Chocolate
DG	Dark Green
G	Green
GY	Gray
LB	Light Blue
LG	Light Green
O	Orange
P	Pink
PU	Purple
R	Red
W	White
Y	Yellow

IGNITION SWITCH CONNECTIONS						
Ignition	Battery	Ignition	Taill	Taill2	Battery	Taill3
BR	W	GY	BL	R	W/BK	O/G
ON						

RIGHT HANDLEBAR SWITCH CONNECTIONS													
Headlight Switch			Front Brake Light Switch			Engine Stop Switch			Starter Button				
Color	BL/Y	BL	R/BL	R/W	Color	BK	BK	Color	Y/R	R	Color	BK/R	BK/P
OFF					Brake Level			OFF					
ON					Pulled In			RUN					