

**SUZUKI**

**GSX250F**

**SERVICE MANUAL**

99500-32060-01E

(英)

## FOREWORD

The SUZUKI GSX250F has been developed as a new generation motorcycle to the GS-models. It is packed with highly advanced design concepts including a Suzuki Advanced Cooling System, a new highly efficient combustion system, a fully transistorized ignition system and a improved link type rear suspension. Combined with precise control and easy handling the GSX250F provides excellent performance and outstanding riding comfort.

This service manual has been produced primarily for experienced mechanics whose job is to inspect, adjust, repair and service SUZUKI motor cycles.

Apprentice mechanics and do-it-yourself mechanics, will also find this manual as an extremely useful repair guide. This manual contains the most up-to-date information at the time of publication. The rights are reserved to update or make corrections to this manual at any time.

**SUZUKI MOTOR CORPORATION**  
Motorcycle Technical Service Department

## GROUP INDEX

<b>GENERAL INFORMATION</b>	<b>1</b>
<b>PERIODIC MAINTENANCE AND TUNE-UP PROCEDURES</b>	<b>2</b>
<b>ENGINE</b>	<b>3</b>
<b>COOLING SYSTEM</b>	<b>4</b>
<b>FUEL AND LUBRICATION SYSTEM</b>	<b>5</b>
<b>ELECTRICAL SYSTEM</b>	<b>6</b>
<b>CHASSIS</b>	<b>7</b>
<b>SERVICING INFORMATION</b>	<b>8</b>

# GENERAL INFORMATION

1

## CONTENTS

<b>VIN AND SERIAL NUMBER LOCATIONS</b> .....	<b>1- 1</b>
<b>FUEL, OIL AND COOLING SOLUTION RECOMMENDATIONS</b> .....	<b>1- 1</b>
<b>FUEL</b> .....	<b>1- 1</b>
<b>ENGINE OIL</b> .....	<b>1- 1</b>
<b>FRONT FORK OIL</b> .....	<b>1- 1</b>
<b>BRAKE FLUID</b> .....	<b>1- 1</b>
<b>COOLING SOLUTION</b> .....	<b>1- 2</b>
<b>BREAKING-IN PROCEDURES</b> .....	<b>1- 2</b>
<b>CYLINDER IDENTIFICATION</b> .....	<b>1- 2</b>
<b>SPECIAL MATERIALS</b> .....	<b>1- 3</b>
<b>PRECAUTIONS AND GENERAL INSTRUCTIONS</b> .....	<b>1- 5</b>
<b>REPLACEMENT PARTS</b> .....	<b>1- 5</b>
<b>SPECIFICATIONS</b> .....	<b>1- 6</b>

## VIN AND SERIAL NUMBER LOCATIONS

The frame serial number or V.I.N. (Vehicle Identification Number) ① is stamped on the steering head pipe. The engine serial number ② is located on the right side of the upper crankcase. These numbers are required especially for registering the machine and ordering spare parts.

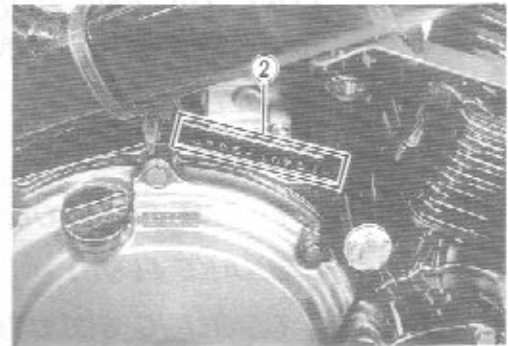
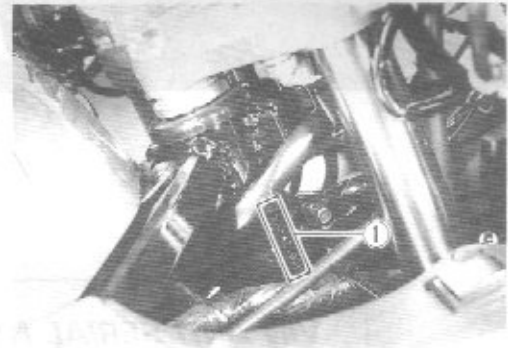

## FUEL, OIL AND COOLING SOLUTION RECOMMENDATIONS

### FUEL

Gasoline used should be graded 85–95 octane or higher. An unleaded gasoline is recommended.

### ENGINE OIL

Be sure that the engine oil you use comes under API classification of SE or SF and that its viscosity rating is SAE 10W/40. If an SAE 10W/40 motor oil is not available, select the oil viscosity according to the right chart.

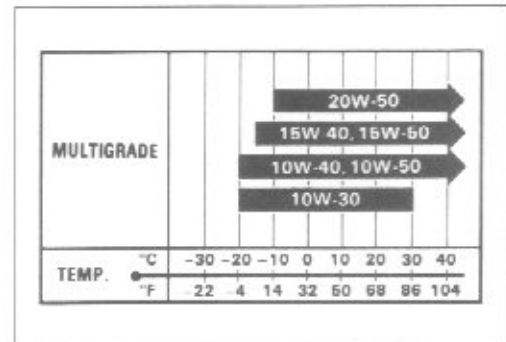

### FRONT FORK OIL

Use fork oil # 10.

99000-99044-10G: SUZUKI FORK OIL # 10

### BRAKE FLUID

specification and classification: DOT 4

99000-23110: SUZUKI BRAKE FLUID

## COOLING SOLUTION

Use an anti-freeze & Summer coolant compatible with aluminum radiator, mixed with distilled water only, at ratio of 50 : 50.

## WATER FOR MIXING

Use distilled water only. Water other than distilled water can corrode and clog the aluminum radiator.

## ANTI-FREEZE & SUMMER COOLANT

The coolant performs as corrosion and rust inhibitor as well as anti-freeze. Therefore, the coolant should be used at all times even though the atmospheric temperature in your area does not go down to freezing point.

SUZUKI recommends the use of SUZUKI GOLDEN CRUISER 1200NA anti-freeze & summer coolant. If this is not available, use an equivalent which is compatible with aluminum radiator.

**99000-99032-10X : SUZUKI GOLDEN CRUISER 1200NA (Non-Amine type)**

## REQUIRED AMOUNT OF WATER/COOLANT

Solution capacity (total) : 2 000 ml (2.1/1.8 US/lmp qt)

## CAUTION:

Mixing of anti-freeze & summer coolant should be limited to 60%. Mixing beyond it would reduce its efficiency. If the anti-freeze & summer coolant mixing ratio is below 30%, rust inhibiting performance is greatly reduced. Be sure to mix it above 30% even though the atmospheric temperature does not go down to freezing point.

## BREAKING-IN PROCEDURES

During manufacture only the best possible materials are used and all machined parts are finished to a very high standard, but it is still necessary to allow the moving parts to "BREAK-IN" before subjecting the engine to maximum stresses. The future performance and reliability of the engine depends on the care and restraint exercised during its early life. The general rules are as follows.

- Keep to these breaking-in engine speed limits.
- |                              |                      |
|------------------------------|----------------------|
| Initial 800 km (500 miles)   | : Below 7 000 r/min  |
| Up to 1 600 km (1 000 miles) | : Below 10 000 r/min |
| Over 1 600 km (1 000 miles)  | : Below 16 500 r/min |



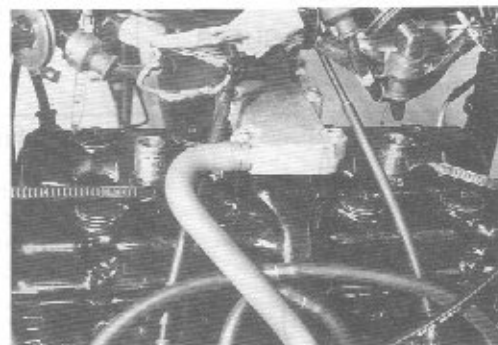

## CYLINDER IDENTIFICATION





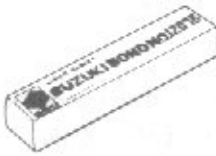

The four cylinders of this engine are identified as No.1, No.2, No.3 and No.4 cylinder, as counted from the left hand. (as viewed by rider on the seat)



## SPECIAL MATERIALS

The materials listed below are needed for maintenance work on the GSX250F, and should be kept on hand for ready use. They supplement such standard materials as cleaning fluids, lubricants, emery cloth and the like. How to use them and where to use them are described in the text of this manual.

MATERIAL	PART	PAGE	PART	PAGE
 <p>SUZUKI SUPER GREASE "A" 99000-25010</p>	<ul style="list-style-type: none"> <li>• Starter motor oil seal and O-ring</li> <li>• Wheel bearing</li> <li>• Steering stem bearings</li> <li>• Sprocket mounting drum bearing</li> <li>• Water pump oil seal</li> </ul>	<p>6-10</p> <p>7-3 7-28 7-30</p> <p>7-23 7-28 7-30 5-11</p>	<ul style="list-style-type: none"> <li>• Swingarm bearing, spacer and dust seal cover</li> <li>• Cushion lever bearing, spacer and dust seal</li> <li>• Speedometer gear box</li> </ul>	<p>7-36 7-40 7-36 7-40 7-3</p>
 <p>SUZUKI MOLY PASTE 99000-25140</p>	<ul style="list-style-type: none"> <li>• Valve stem</li> <li>• Conrod big end bearing</li> <li>• Countershaft and drive-shaft</li> <li>• Crankshaft journal bearing</li> <li>• Camshaft journal</li> <li>• Starter motor armature end</li> </ul>	<p>3-21</p> <p>3-31 3-37</p> <p>3-40 3-50 6-10</p>		
 <p>SUZUKI BOND NO.1207B 99000-31140</p>	<ul style="list-style-type: none"> <li>• Crankcase mating surface</li> <li>• Mating surface between crankcases and starter clutch cover, clutch cover</li> <li>• Oil pressure switch</li> <li>• Cylinder head cover</li> <li>• Water thermo-gauge</li> <li>• Water pump mechanical seal</li> </ul>	<p>3-40</p> <p>3-43 3-46</p> <p>3-47</p> <p>3-52</p> <p>5-7 5-11</p>		
 <p>THREAD LOCK SUPER "1303" 99000-32030</p>	<ul style="list-style-type: none"> <li>• Cam sprocket bolt</li> </ul>	<p>3-25</p>		
 <p>THREAD LOCK "1342" 99000-32050</p>	<ul style="list-style-type: none"> <li>• Gearshift cam stopper bolt</li> <li>• Countershaft bearing retainer screw</li> <li>• Gearshift cam guide/pawl lifter screw</li> <li>• Starter motor mounting bolt</li> </ul>	<p>3-41</p> <p>3-43</p>	<ul style="list-style-type: none"> <li>• Front fork damper rod bolt</li> </ul>	<p>7-21</p>

MATERIAL	PART	PAGE	PART	PAGE
 <p>THREAD LOCK SUPER "1305" 99000-32100</p>	<ul style="list-style-type: none"> <li>• Generator rotor bolt</li> </ul>	3-42		
 <p>THREAD LOCK "1360" 99000-32130</p>	<ul style="list-style-type: none"> <li>• Disc plate mounting bolt</li> </ul>	7-3 7-5		
 <p>SUZUKI SILICONE GREASE 99000-25100</p>	<ul style="list-style-type: none"> <li>• Front brake caliper</li> </ul>	7-12		
 <p>SUZUKI BRAKE FLUID DOT3 &amp; DOT4 99000-23110</p>	<ul style="list-style-type: none"> <li>• Brakes</li> </ul>	1-1 2-14 7-17		
 <p>SUZUKI FORK OIL #10 99000-99044 10G</p>	<ul style="list-style-type: none"> <li>• Front fork</li> </ul>	7-22		
 <p>SUZUKI GOLDEN CRUISER 1200NA (Non-Amine type) 99000-99032-10X</p>		1-2		

## PRECAUTIONS AND GENERAL INSTRUCTIONS

Observe the following items without fail when disassembling and reassembling motorcycles.

- Do not run engine indoors with little or no ventilation.
- Be sure to replace packings, gaskets, circlips, O-rings and cotter pins with new ones.

### CAUTION:

Never reuse a circlip after a circlip has been removed from a shaft, it should be discarded and a new circlip must be installed.

When installing a new circlip, care must be taken not to expand the end gap larger than required to slip the circlip over the shaft.

After installing a circlip, always insure that it is completely seated in its groove and securely fitted.

- Tighten cylinder head and case bolts and nuts beginning with larger diameter and ending with smaller diameter, and from inside to outside diagonally, to the specified tightening torque.
- Use special tools where specified.
- Use genuine parts and recommended oils.
- When more than 2 persons perform work together, pay attention to the safety of each other.
- After the reassembly, check parts for tightness and operation.
- Treat gasoline, which is extremely flammable and highly explosive, with greatest care. Never use gasoline as cleaning solvent.

Warning, Caution and Note are included in this manual occasionally, describing the following contents.

**WARNING** ..... The personal safety of the rider or bystanders may be involved. Disregarding this information could result in personal injury.

**CAUTION** ..... These instructions point out special service procedures or precautions that must be followed to avoid damaging the machine.

**NOTE** ..... This provides special information to make maintenance easier or important instructions clearer.

## REPLACEMENT PARTS

When you replace any parts, use only genuine SUZUKI replacement parts, or their equivalent. Genuine SUZUKI parts are high quality parts which are designed and built specifically for SUZUKI vehicles.

### CAUTION:

Use of replacement parts which are not equivalent in quality to genuine SUZUKI parts can lead to performance problems and damage.

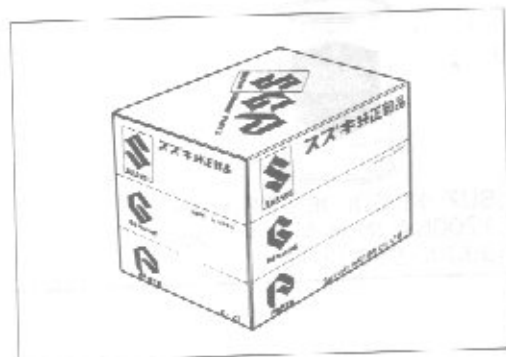



## SPECIFICATIONS

### DIMENSIONS AND DRY MASS

Overall length .....	2 020 mm (79.5 in)
Overall width .....	695 mm (27.4 in)
Overall height .....	1 120 mm (44.1 in)
Wheelbase .....	1 380 mm (54.3 in)
Seat height .....	770 mm (30.3 in)
Ground clearance .....	140 mm ( 5.5 in)
Dry mass .....	163 kg (359 lbs)

### ENGINE

Type .....	Four-stroke, water-cooled, DOHC
Number of cylinders ..	4
Bore .....	49.0 mm (1.929 in)
Stroke .....	33.0 mm (1.299 in)
Piston displacement ...	248 cm <sup>3</sup> (15.1 cu.in)
Compression ratio ...	12.5 : 1
Carburetor .....	MIKUNI BSW27, two
Air cleaner .....	Non-woven fabric element
Starter system .....	Electric starter motor
Lubrication system ...	Wet sump

### TRANSMISSION

Clutch .....	Wet multi-plate type
Transmission .....	6-speed constant mesh
Gearshift pattern .....	1-down, 5-up
Primary reduction ....	2.285 (80/35)
Final reduction .....	3.769 (49/13)
Gear ratios, Low .....	3.083 (37/12)
2nd .....	2.200 (33/15)
3rd .....	1.722 (31/18)
4th .....	1.450 (29/20)
5th .....	1.315 (25/19)
Top .....	1.227 (27/22)
Drive chain .....	DAIDO: DID520V <sub>7</sub> , TAKASAGO: RK520SMO, 110 links

### CHASSIS

Front suspension .....	Telescopic, coil spring, oil damped
Rear suspension .....	Link type, coil spring, oil damped, spring pre-load 7-way adjustable
Steering angle .....	33° (right & left)
Caster .....	64° 10'
Trail .....	102 mm (4.0 in)
Turning radius .....	2.9 m (9.5 ft)
Front brake .....	Disc
Rear brake .....	Disc
Front tire size .....	110/70-17 54H
Rear tire size .....	140/70 17 66H
Front fork stroke .....	130 mm (5.1 in)
Rear wheel travel .....	122 mm (4.8 in)

### ELECTRICAL

Ignition type .....	Transistorized
Ignition timing .....	22° B.T.D.C. below 1800 r/min
Spark plug .....	NGK CR7HSA or ND U22FSR-U
Battery .....	12V 21.6 kC (6Ah)/10HR
Generator .....	Three-phase A.C. generator
Fuse .....	25/10/10/10A

### CAPACITIES

Fuel tank	
including reserve ...	12L (3.2/2.6 US/Imp gal)
reserve .....	2.0L (0.5/0.4 US/Imp gal)
Engine oil change ....	2.6L (2.7/2.3 US/Imp qt)
with filter change ...	2.9L (3.1/2.6 US/Imp qt)
Front fork oil .....	401 ml (13.6/14.1 US/Imp oz)
Coolant	
including reserve ...	2.0L (2.1/1.8 US/Imp qt)

\*These specifications are subject to change without notice.

# PERIODIC MAINTENANCE AND TUNE-UP PROCEDURES

## CONTENTS

<b>PERIODIC MAINTENANCE SCHEDULE</b> .....	2- 1
<b>PERIODIC MAINTENANCE CHART</b> .....	2- 1
<b>LUBRICATION POINTS</b> .....	2- 2
<b>MAINTENANCE AND TUNE-UP PROCEDURES</b> .....	2- 3
<b>BATTERY</b> .....	2- 3
<b>AIR CLEANER</b> .....	2- 4
<b>EXHAUST PIPE BOLTS</b> .....	2- 4
<b>TAPPET CLEARANCE</b> .....	2- 5
<b>SPARK PLUG</b> .....	2- 8
<b>ENGINE OIL AND OIL FILTER</b> .....	2- 8
<b>FUEL LINES</b> .....	2- 9
<b>CARBURATORS</b> .....	2-10
<b>COOLING SYSTEM</b> .....	2-10
<b>CLUTCH</b> .....	2-11
<b>DRIVE CHAIN</b> .....	2-12
<b>BRAKES</b> .....	2-14
<b>TIRES</b> .....	2-16
<b>STEERING</b> .....	2-17
<b>FRONT FORK</b> .....	2-17
<b>REAR SUSPENSION</b> .....	2-17
<b>CHASSIS BOLTS AND NUTS</b> .....	2-18

## PERIODIC MAINTENANCE SCHEDULE

The chart below lists the recommended intervals for all the required periodic service work necessary to keep the motorcycle operating at peak performance and economy. Mileages are expressed in terms of kilometer, miles and time for your convenience.

**NOTE:**

More frequent servicing may be performed on motorcycles that are used under severe conditions.

### PERIODIC MAINTENANCE CHART

Item	Interval	km	1 000	5 000	10 000	15 000
		miles	600	3 000	6 000	9 500
		months	2	15	30	45
Battery			—	I	I	I
Air cleaner		Clean every 3 000 km (2 000 miles) and replace every 12 000 km (7 500 miles)				
Exhaust pipe bolts			T	T	T	T
Tapet clearance			I	I	I	I
Spark plugs			—	I	R	I
Engine oil and oil filter			R	R	R	R
Fuel lines			I	I	I	I
		Replace every four years				
Carburetors			I	I	I	I
Radiator hoses			I	—	I	—
		Replace every four years				
Coolant		Replace every two years				
Clutch			I	I	I	I
Drive chain			I	I	I	I
		Clean and lubricate every 1 000 km (600 miles)				
Brakes			I	I	I	I
Brake hoses			I	I	I	I
		Replace every four years				
Brake fluid			I	I	I	I
		Replace every two years				
Tires			I	I	I	I
Steering			I	I	I	I
Front fork			I	I	—	I
Rear suspension			I	I	—	I
Chassis bolts and nuts			T	T	T	T

**NOTE:**

I - Inspect and clean, adjust, replace or lubricate as necessary

R = Replace      T = Tighten

## LUBRICATION POINTS

Proper lubrication is important for smooth operation and long life of each working part of the motorcycle. Major lubrication points are indicated below.

- Ⓜ : Grease
- Ⓞ : Oil

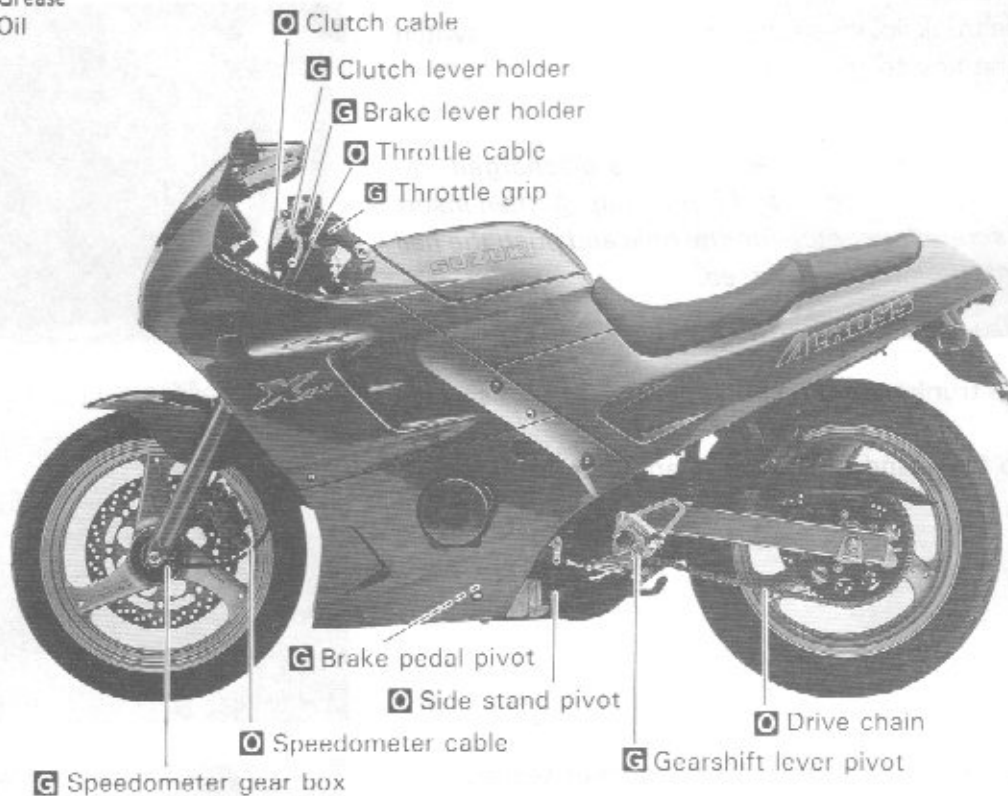

### NOTE:

- \* Before lubricating each part, clean off any rusty spots and wipe off any grease, oil, dirt or grime.
- \* Lubricate exposed parts, other than the points mentioned on above, which are subject to rust.

## MAINTENANCE AND TUNE-UP PROCEDURES

This section describes the servicing procedures for each item of the Periodic Maintenance requirements.

### BATTERY

Inspect Every 5 000 km (15 months)

- Remove the seat.
- To open the trunk lid, insert the key into the ignition switch and turn the key to the "OPEN" position.

#### NOTE:

To open the trunk lid when the battery is discharged, remove the screws ①, plate ② and rubber cap ③ then insert the negative screwdriver etc. into the hole and push the nail ④ down until the latch is released.

- Remove the trunk mounting bolts (⑤ and ⑥) and screws (⑦).
- Pull up the front end of the trunk and lean it rearward.

- Check the battery voltage with the pocket tester.

#### 09900-25002: Pocket tester

If voltage reading is below 12.0 V, this battery needs recharging.

**Battery voltage: Above 12V**

- Disconnect the battery  $\ominus$  and  $\oplus$  lead wires and remove the battery.

#### WARNING:

When disconnecting the battery lead wire,  $\ominus$  lead wire first.

#### CAUTION:

Read the "ELECTRICAL SECTION", for the servicing battery.

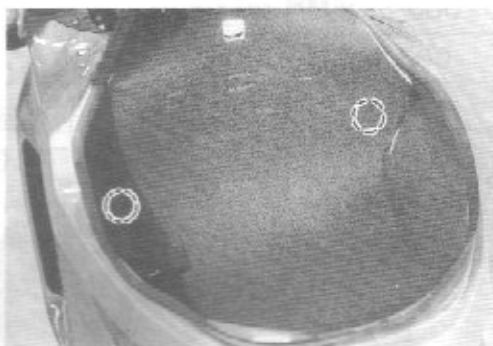
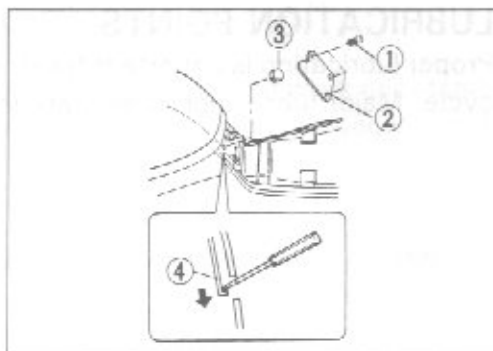

## AIR CLEANER

Clean Every 3 000 km and Replace Every 12 000 km

- Open the trunk. (Refer to page 2-3.)
- Remove the air cleaner case cover.

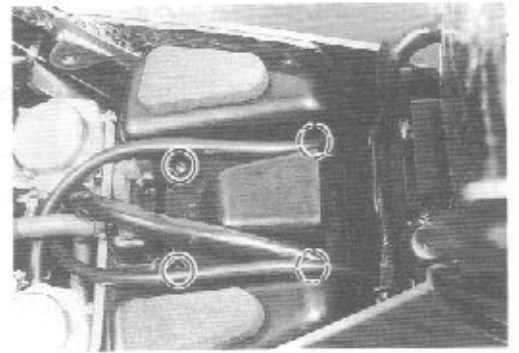

- Remove the air cleaner element.

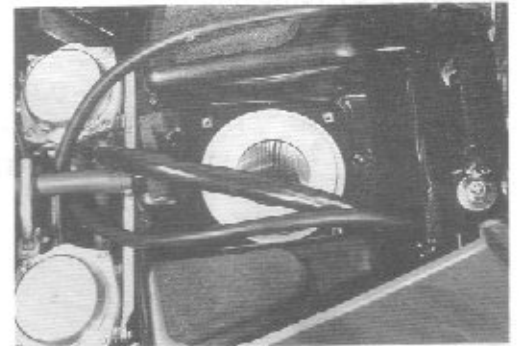

- Carefully use air hose to blow the dust from the outside of cleaner element.

### CAUTION:

Always use air pressure on the outside of the cleaner element. If air pressure is used on the inside, dirt will be forced into the pores of the cleaner element thus restricting air flow through the cleaner element.

- Reinstall the cleaned or new cleaner element in the reverse order of removal.

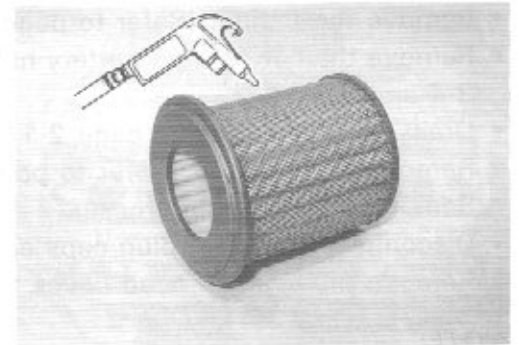

### CAUTION:

If driving under dusty conditions, clean the air cleaner element more frequently. The surest way to accelerate engine wear is to use the engine without the element or to use a ruptured element. Make sure that the air cleaner is in good condition at all times. Life of the engine depends largely on this component!

## EXHAUST PIPE BOLTS

Tighten Initial 1 000 km (2 months) and Every 5 000 km (15 months)

- Tighten the exhaust pipe bolts to the specified torque.

Tightening torque: 8–12 N·m  
(0.8–1.2 kg·m, 6.0–8.5 lb-ft)

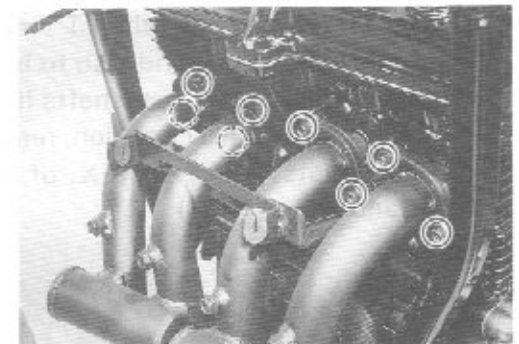

## TAPPET CLEARANCE

Inspect Initial 1 000 km (2 months) and  
Every 5 000 km (15 months)

The tappet clearance specifications in the different for both intake and exhaust.

Tappet clearance adjustment must be checked and adjusted, 1) at the time of periodic inspection, 2) when the tappet mechanism is serviced, and 3) when the camshafts are disturbed by removing them for servicing.

**Tappet clearance** IN: 0.17–0.27 mm  
(when cold) (0.007–0.011 in)  
EX: 0.20–0.30 mm  
(0.008–0.012 in)

- Remove the fairing. (Refer to page 7-1.)
- Remove the battery and battery holder. (Refer to pages 3-4 and 3-5.)
- Drain coolant. (Refer to page 2-11.)
- Remove the radiator. (Refer to page 5-2.)
- Remove the thermostat case.
- Disconnect the spark plug caps and breather hose.
- Remove the cylinder head cover.

### NOTE:

- \* The cam must be at positions, (A) or (B), in order to check the tappet clearance. Clearance readings should not be taken with the cam in any other position than these two positions.
- \* The clearance specification is for COLD state.
- \* To turn the crankshaft for clearance checking, be sure to use a 22 mm wrench and rotate in the normal running direction. All spark plugs should be removed.



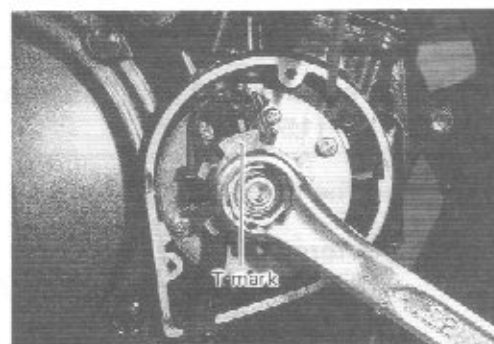
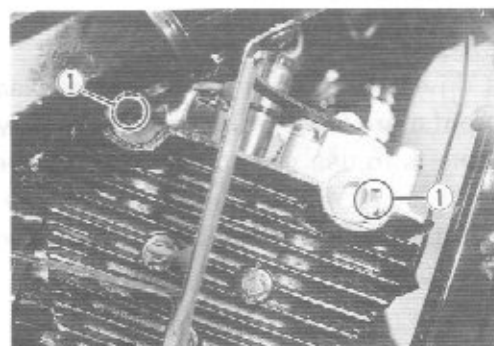
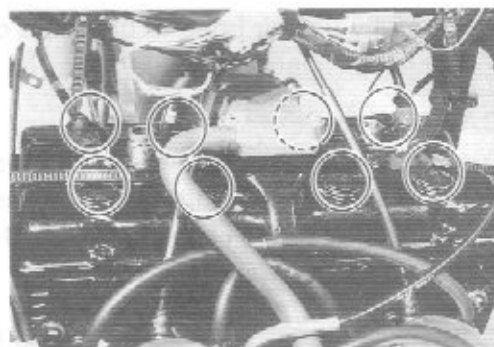
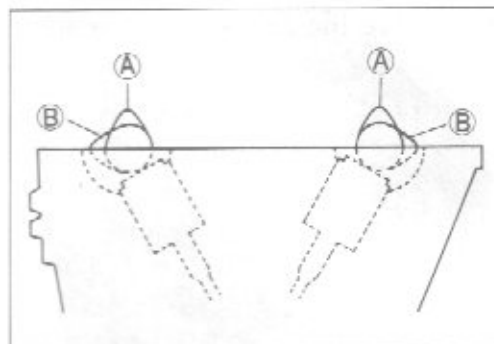

- Turn crankshaft to bring the "T" mark on the rotor to the center of pick-up coil and also to bring the notches (1) in the right ends of both camshafts (IN. and EX.) to the positions shown. In this condition, read the tappet clearance at the tappets (C) (IN. and EX. of No.1 cylinder, EX. of No.2 and IN. of No.3).



- Use the thickness gauge between tappet and cam to check the clearance.

#### 09900-20803: Thickness gauge

- Turn the crankshaft 360° (one rotation) to bring the "T" mark on the rotor to the center of pick-up coil and also to bring the notches ① to the positions as shown.
- Read the clearance at the remaining tappets ② and adjust the clearance if necessary.

Cam Position	Notch ① position	
	Intake Camshaft	Exhaust Camshaft
Ⓒ		
Ⓓ		

#### TAPPET CLEARANCE ADJUSTMENT

- Remove the camchain tensioner. (Refer to page 3-9.)
- Remove the camshafts. (Refer to page 3-9.)
- Remove the tappets. (Refer to page 3-18.)
- Replace the shim with a magnetic bar etc.
- Check the figures printed on the shim. These figures indicate the thickness of the shim, as illustrated.
- Select a replacement shim that will provide a clearance within the specified range (IN.: 0.17–0.27 mm, EX.: 0.20–0.30 mm). For the purpose of this adjustment, a total of 41 sizes of tappet shim are available ranging from 1.200 mm to 2.200 mm in steps of 0.025 mm. Fit the selected shim to the spring retainer, with numbers toward tappet. Be sure to check shim sized with micrometer to insure its size.

#### NOTE:

- \* Before fitting the tappet shim to the spring retainer, be sure to apply engine oil to its top and bottom faces.
- \* When seating tappet shim, be sure to face figure printed surface to the tappet.

- To check the tappet clearance, reassemble each tappet, camshafts, camchain and camchain tensioner. (Refer to page 3-51.)
- Turn the crankshaft two turns and bring the position to T.D.C. and check the tappet clearance. If the correct clearance not has been obtained, readjust the clearance until correct range.

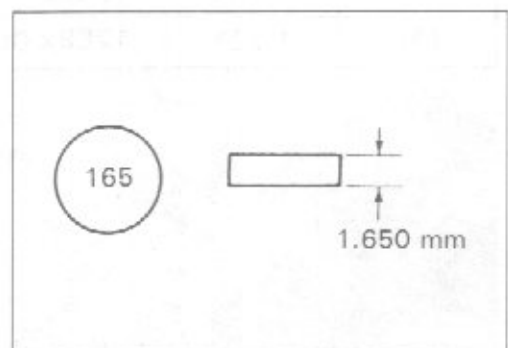
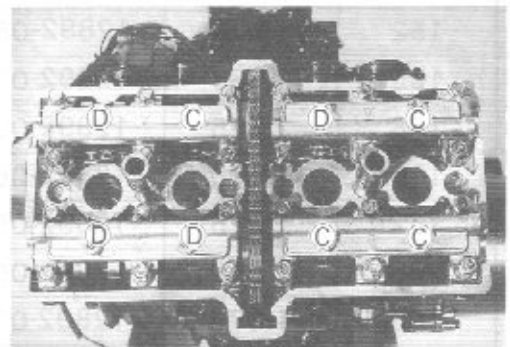
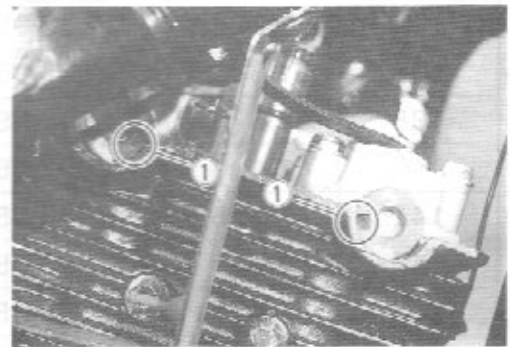
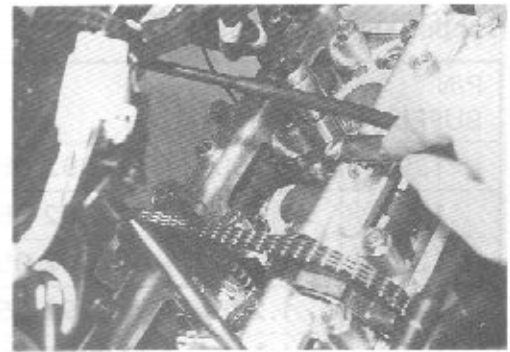



Tappet shim size chart

P/N SUFFIX	Thickness (mm)	Part No.	P/N SUFFIX	Thickness (mm)	Part No.
120	1.200	12892-05C00-120	175	1.750	12892-05C00-175
122	1.225	12892-05C00-122	178	1.775	12892-05C00-178
125	1.250	12892-05C00-125	180	1.800	12892-05C00-180
128	1.275	12892-05C00-128	182	1.825	12892-05C00-182
130	1.300	12892-05C00-130	185	1.850	12892-05C00-185
132	1.325	12892-05C00-132	188	1.875	12892-05C00-188
135	1.350	12892-05C00-135	190	1.900	12892-05C00-190
138	1.375	12892-05C00-138	192	1.925	12892-05C00-192
140	1.400	12892-05C00-140	195	1.950	12892-05C00-195
142	1.425	12892-05C00-142	198	1.975	12892-05C00-198
145	1.450	12892-05C00-145	200	2.000	12892-05C00-200
148	1.475	12892-05C00-148	202	2.025	12892-05C00-202
150	1.500	12892-05C00-150	205	2.050	12892-05C00-205
152	1.525	12892-05C00-152	208	2.075	12892-05C00-208
155	1.550	12892-05C00-155	210	2.100	12892-05C00-210
158	1.575	12892-05C00-158	212	2.125	12892-05C00-212
160	1.600	12892-05C00-160	215	2.150	12892-05C00-215
162	1.625	12892-05C00-162	218	2.175	12892-05C00-218
165	1.650	12892-05C00-165	220	2.200	12892-05C00-220
168	1.675	12892-05C00-168			
170	1.700	12892-05C00-170			
172	1.725	12892-05C00-172			

## SPARK PLUG

**Inspect Every 5 000 km (15 months) and Replace Every 10 000 km (30 months)**

Remove the carbon deposits with a wire or pin and adjust the spark plug gap to 0.6–0.7 mm (0.024–0.028 in) measuring with a thickness gauge.

When removing carbon deposits, be sure to observe the appearance of the plug, noting the color of the carbon deposits. The color observed indicates whether the standard plug is suitable or not. If the standard plug is apt to get wet, replace with hotter one.

	NGK	ND
Hot type	CR6HSA	U20FSR-U
<b>Standard</b>	<b>CR7HSA</b>	<b>U22FSR-U</b>
Cold type	CR8HSA	U24FSR-U

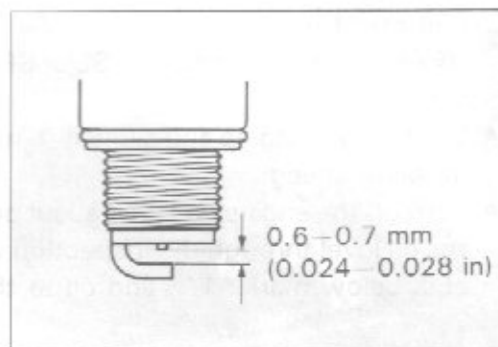
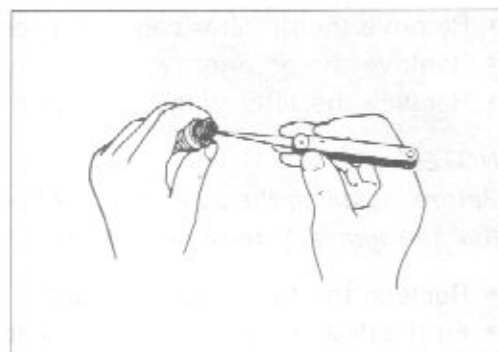

### CAUTION:

Confirm the thread size and reach when replacing the plug.

## ENGINE OIL AND OIL FILTER

**Replace (change) Initial 1 000 km (2 months) and Every 5 000 km (15 months)**

Oil should be changed while the engine is hot. Oil filter replacement at the above intervals should be done together with engine oil change.

- Remove the filler cap cover ①.
- Keep the motorcycle upright.
- Place an oil pan below the engine and drain oil to remove the drain plug ② and filler cap ③.

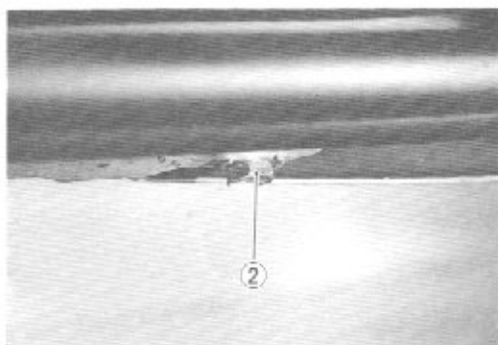
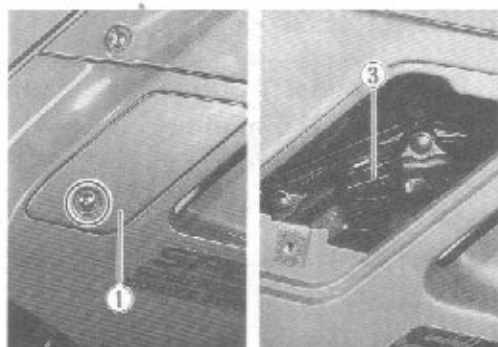

- Remove the oil filter cap ① by removing the nuts.
- Remove the oil filter ②.
- Replace the filter with a new one.

**NOTE:**

Before installing the oil filter and filter cap check to be sure that the spring ③ and a new O-ring ④ are installed correctly.

- Replace the filter cap and tighten the nuts securely.
- Fit the drain plug securely, and add fresh oil through the oil filler. The engine will hold about 2.9 L (3.1/2.6 US/Imp qt) of oil.  
Use an API classification of SE or SF oil with SAE 10W/40 viscosity.
- Start up the engine and allow it to run for several seconds at idling speed.
- Turn off the engine and wait about one minute, then check the oil level through the inspection window ⑤. If the level is below mark "F", add oil to that level.

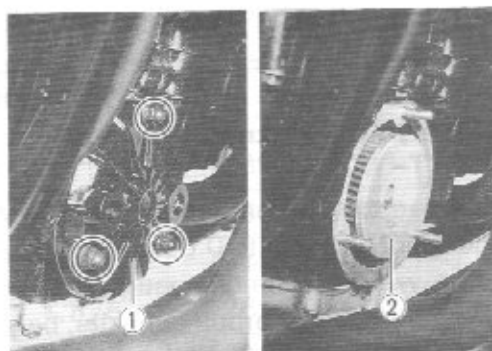

**NECESSARY AMOUNT OF ENGINE OIL**

Oil change	2.6 L (2.7/2.3 US/Imp qt)
Filter change	2.9 L (3.1/2.6 US/Imp qt)
Overhaul engine	3.2 L (3.4/2.8 US/Imp qt)

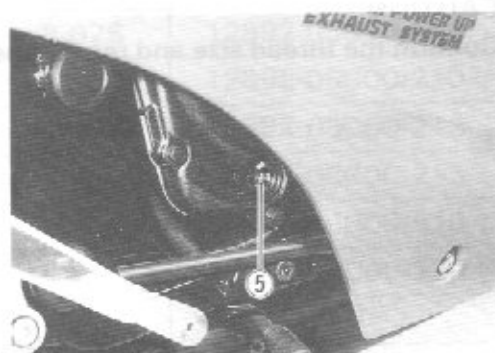

**FUEL LINES**

Inspect initial 1 000 km (2 months) and Every 5 000 km (15 months)  
Replace Every four years

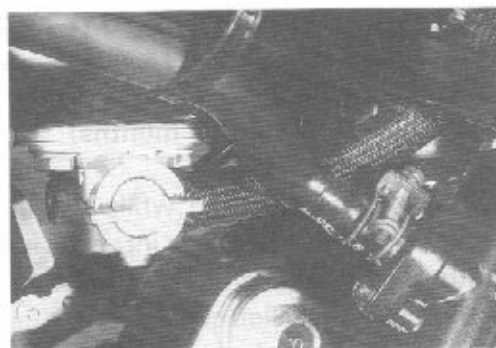

## CARBURETORS

Inspect Initial 1 000 km (2 months) and Every  
5 000 km (15 months)

### IDLE R/MIN (Idling adjustment)

#### NOTE:

Make this adjustment when the engine is hot.

- Start up the engine and set its speed at anywhere between 1 500 and 1 700 r/min to turn throttle stop screw ①.

Engine idle speed: 1 600  $\pm$  100 r/min

### THROTTLE CABLE PLAY

There should be 0.5–1.0 mm (0.02–0.04 in) play (A) on the throttle cable.

Adjust the throttle cable play by the following procedures.

- Loosen the lock nut ② and turn the adjuster ③ until the specified play can be obtained.
- Tighten the lock nut ② while holding the adjuster.

Throttle cable play (A) : 0.5–1.0 mm (0.02–0.04 in)

#### WARNING:

After the adjustment is completed, check that handlebar movement does not raise the engine idle speed and that the throttle grip returns smoothly and automatically.

### CHOKE CABLE PLAY

- Loosen the lock nut ④ and turn the adjuster ⑤ until the specified play can be obtained.
- Tighten the lock nut.

Choke cable play (B) : 0.5–1.0 mm (0.02–0.04 in)

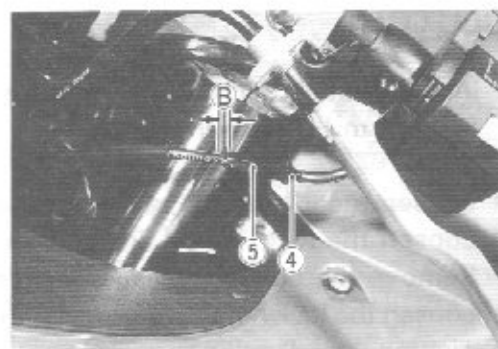
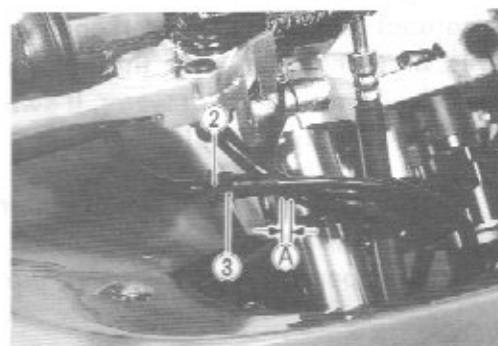
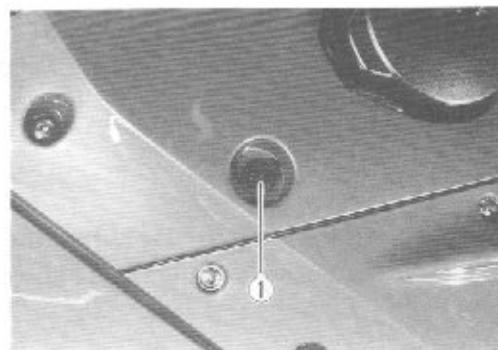

## COOLING SYSTEM

Inspect Initial 1 000 km (2 months) and Every  
5 000 km (15 months)

Replace (change) coolant Every 2 years

Replace hoses Every 4 years

- Loosen the screw and remove the radiator cap ①.
- Remove the drain plug ② and disconnect the hose, and drain coolant thoroughly while holding the motorcycle upright.

**WARNING:**

Do not open the radiator cap when the engine is hot, as you may be injured by escaping hot liquid or vapor.

**WARNING:**

Cooling solution may be harmful if swallowed or if it comes in contact with skin or eyes. If cooling solution gets into the eyes or in contact with the skin, it should be flushed thoroughly with plenty of water. If swallowed, induce vomiting and call physician immediately.

- Flush the radiator with fresh water.
- Tighten the drain plug securely.
- Fill the specified coolant up to the radiator inlet hole.

**NOTE:**

For coolant information, refer to "COOLING SYSTEM" section (page 5-2.)

- Fill the reservoir tank to the "F" level with coolant.
- Close the radiator cap securely.
- After warming up and cooling down the engine, check the coolant level of the reservoir tank and add the coolant to the "F" level if the level is below "L".

Including reservoir tank capacity: 2 000 ml (2.1/1.8 US/Imp qt)  
 Reservoir tank capacity: 150 ml (0.16/0.13 US/Imp qt)

**CLUTCH**

Inspect Initial 1 000 km (2 months) and Every 5 000 km (15 months)

- Loosen the lock nut ③ and turn the adjuster ④ fully in.
- Loosen the lock nut ⑤ and turn in the adjuster ⑥.
- Remove the clutch release adjuster cap.
- Loosen the lock nut ⑦, and loosen the adjusting screw ⑧.
- Tighten the adjusting screw ⑧ until resistance is felt, then loosen it 1/4 turn.
- Tighten the lock nut ⑦.

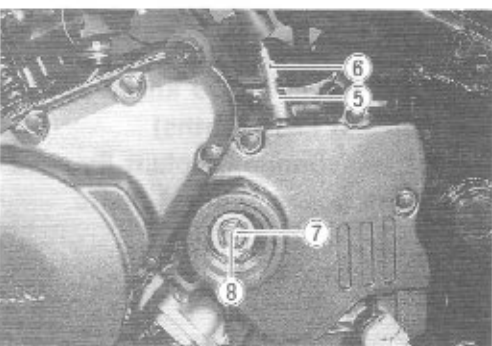
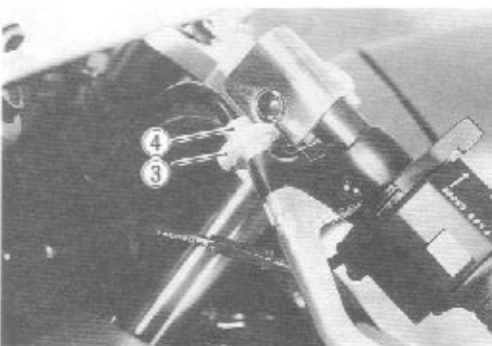
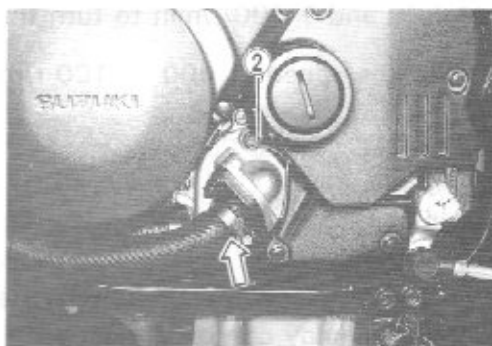
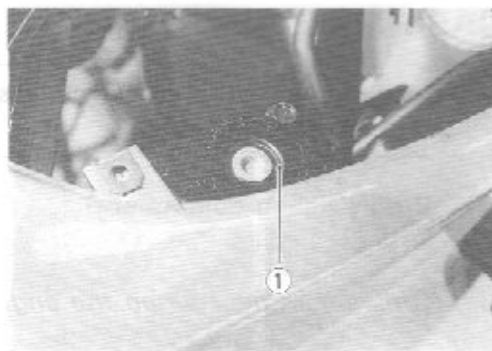

- Adjust the clutch cable adjuster ① until approx. 4 mm of play remains at the bottom of the clutch lever.
- Tighten the lock nuts.

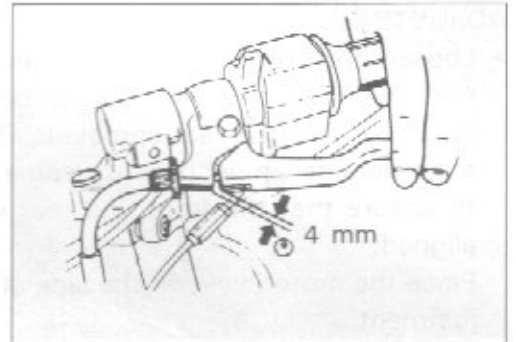
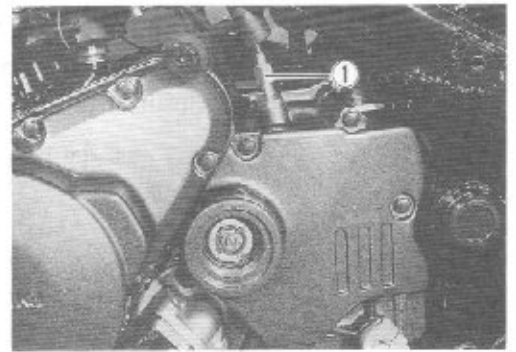

## DRIVE CHAIN

**Inspect Initial 1 000 km (2 months) and Every 5 000 km (15 months)**  
**Clean and Lubricate Every 1 000 km**

Visually inspect the drive chain for the below listed possible malconditions. (Lift the rear wheel and place a jack or block under the engine, and turn the rear wheel slowly by hand, with the transmission in NEUTRAL).

- |                           |                             |
|---------------------------|-----------------------------|
| * Loose pins              | * Excessive wear            |
| * Damaged rollers         | * Improper chain adjustment |
| * Dry or rusted links     | * Missing O-ring or seals   |
| * Kinked or binding links |                             |

If any defects are found, the drive chain must be replaced.

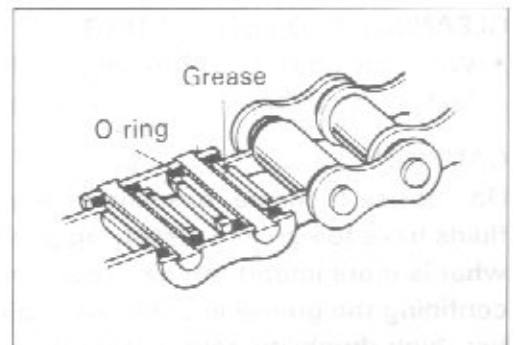

## CHECKING

- Loosen axle nut ①.
- Tense the drive chain fully to screw in the chain adjuster lock nuts ②.

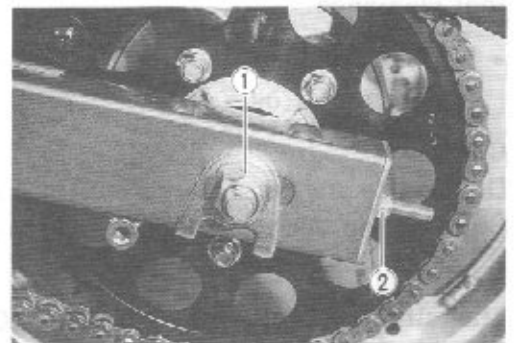

- Count out 21 pins (20 pitches) on the chain and measure the distance between the two points. If the distance exceeds the service limit, the chain must be replaced.

**Service Limit: 319.4 mm (12.57 in)**

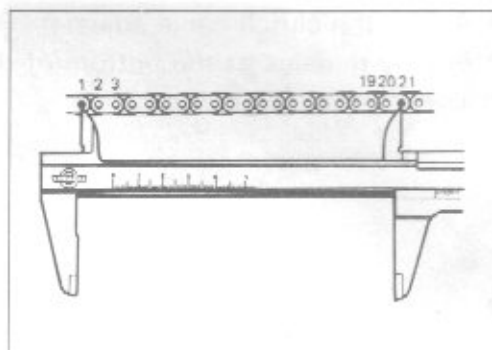

**ADJUSTING**

- Loosen both chain adjuster lock nuts (2) until the chain has 15–25 mm (0.6–1.0 in) of slack at the middle between engine and rear sprockets. The mark (3) on both chain adjusters must be at the same position on the scale to ensure that the front and rear wheels are correctly aligned.

Place the motorcycle on the side stand for accurate adjustment.

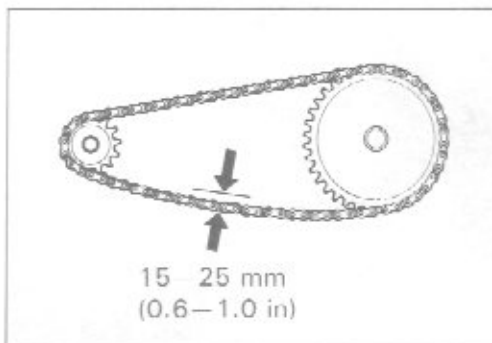

**Drive chain slack: 15–25 mm (0.6–1.0 in)**

- After adjusting the drive chain, tighten the axle nut (1) securely.

**Tightening torque: 55–88 N·m  
(5.5–8.8 kg-m, 40.0–63.5 lb-ft)**

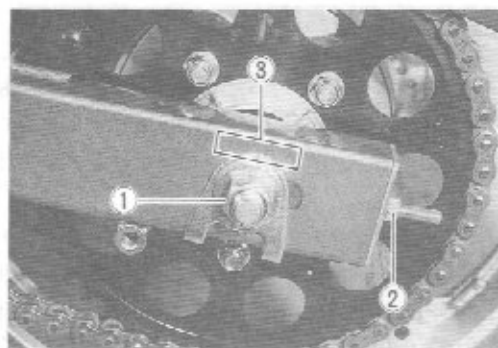

**CLEANING AND LUBRICATING**

- Wash the chain with kerosene. If the chain tends to rust faster, the intervals must be shortened.

**CAUTION:**

Do not use trichlene, gasoline or any similar fluids: These fluids have too great a dissolving power for this chain and, what is more important, can spoil the "O" rings (or seals) confining the grease in the bush to pin clearance. Remember, high durability comes from the presence of grease in that clearance.

- After washing and drying the chain, oil it with a heavy-weight motor oil.

**CAUTION:**

Do not use any oil sold commercially as "drive chain oil". Such oil too can spoil the "O" rings (or seals).

**CAUTION:**

The standard drive chain is DID520V7 or RK520SMO. SUZUKI recommends that the abovementioned standard drive chain be used for the replacement.

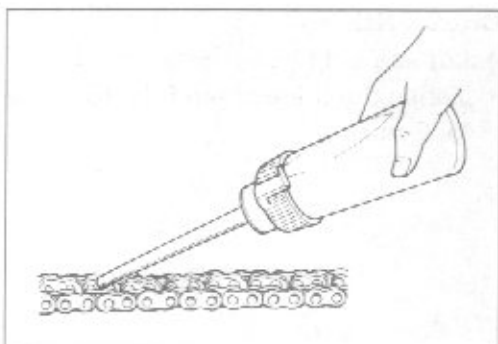
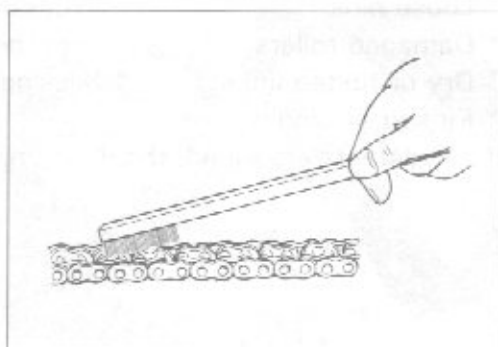

## BRAKES

Inspect Initial 1 000 km (2 months) and Every  
5 000 km (15 months)  
Replace hoses Every 4 years  
Replace (change) fluid Every 2 years

### BRAKE FLUID LEVEL

- Keep the motorcycle upright and place the handlebar straight.
- Check the brake fluid level by observing the upper (only for rear brake) and lower (both front and rear brake) limit lines on the brake fluid reservoirs.
- When the level is below the lower limit line, replenish with brake fluid that meets the following specification.

Specification and classification: DOT 4  
99000-23110: SUZUKI BRAKE FLUID

### WARNING:

The brake system of this motorcycle is filled with a glycol-based brake fluid. Do not use or mix different types of fluid such as silicone-based and petroleum-based. Do not use any brake fluid taken from old, used or unsealed containers. Never re-use the brake fluid left over from the last servicing and stored for long periods.

### WARNING:

Brake fluid, if it leaks, will interfere with safe running and immediately discolor painted surfaces. Check the brake hoses for cracks and hose joints for leakage before riding.

### BRAKE PADS

Wearing condition of brake pads can be checked by observing the limit line (front and rear calipers) marked on the pad. When the wear exceeds the limit mark, replace the pads with new ones. (Refer to page 7-13 and 7-31.)

### BRAKE PEDAL HEIGHT

- Loosen the lock nut ①, and rotate push rod ② to locate brake pedal 50 mm (B) below the top face of the footrest.
- Retighten the lock nut ① to secure the push rod ② in the proper position.

Brake pedal height (B): 50 mm (2.0 in)

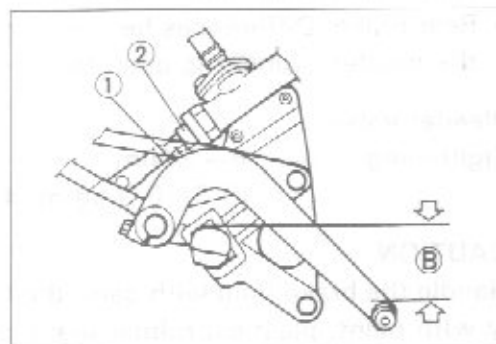
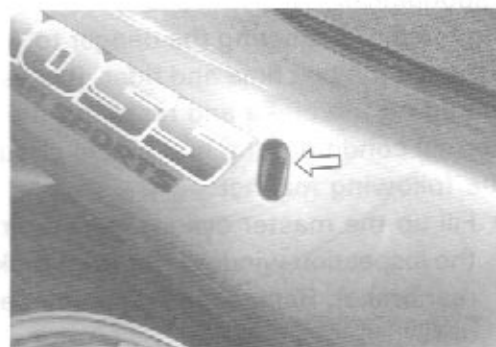



## REAR BRAKE LIGHT SWITCH

Adjust the rear brake light switch, so that brake light will come on just before a pressure is felt when the brake pedal is depressed.

## BLEEDING AIR FROM THE BRAKE FLUID CIRCUIT

Air trapped in the fluid circuit acts like a cushion to absorb a large proportion of the pressure developed by the master cylinder and thus interferes with the full braking performance of the brake caliper. The presence of air is indicated by "sponginess" of the brake lever and also by lack of braking force. Considering the danger to which such trapped air exposes the machine and rider, it is essential that, after re-mounting the brake and restoring the brake system to the normal condition, the brake fluid circuit be purged of air in the following manner:

- Fill up the master cylinder reservoir to the upper end of the inspection window (for front brake) and upper line (for rear brake). Replace the reservoir cap to prevent entry of dirt.
- Attach a pipe to the caliper bleeder valve, and insert the free end of the pipe into a receptacle.
- Front brake: Bleed the air from the bleeder valve.
- Squeeze and release the brake lever several times in rapid succession, and squeeze the lever fully without releasing it. Loosen the bleeder valve by turning it a quarter of a turn so that the brake fluid runs into the receptacle: this will remove the tension of the brake lever causing it to touch the handlebar grip. Then, close the valve, pump and squeeze the lever, and open the valve. Repeat this process until the fluid flowing into the receptacle no longer contains air bubbles.

### NOTE:

*Replenish the brake fluid reservoir as necessary while bleeding the brake system.*

*Make sure that there is always some fluid visible in the reservoir.*

- Close the bleeder valve, and disconnect the pipe. Fill the reservoir to the upper end of the inspection window (for front brake) and upper line (for rear brake).
- Rear brake: Differences between front and rear are that the master cylinder is actuated by a pedal.

### Bleeder valve

Tightening torque: 6–9 N·m  
(0.6–0.9 kg-m, 4.5–6.5 lb-ft)

### CAUTION:

Handle the brake fluid with care: the fluid reacts chemically with paint, plastics, rubber materials, etc.

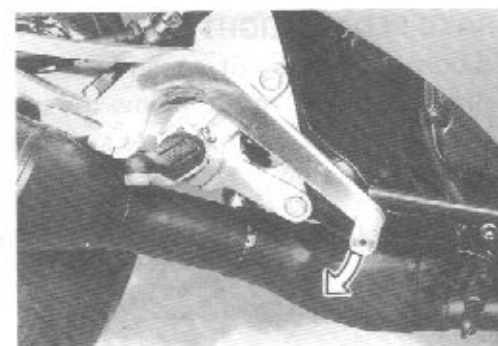
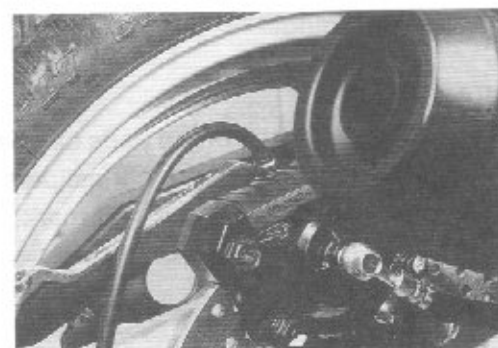
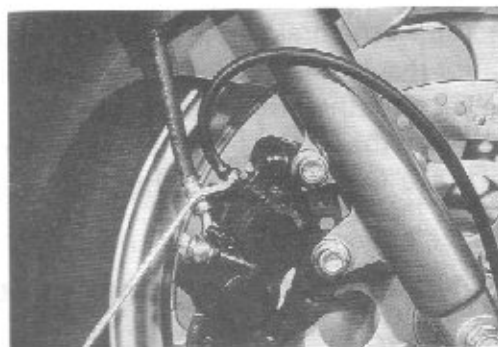

## TIRES

Inspect Initial 1 000 km (2 months) and Every  
5 000 km (15 months)

### TIRE TREAD CONDITION

Operating the motorcycle with excessively worn tires will decrease riding stability and consequently invite a dangerous situation. It is highly recommended to replace the tire when the remaining depth of tire tread reaches the following specifications.

#### Tire tread depth

Service Limit (Front): 1.6 mm (0.06 in)

(Rear) : 2.0 mm (0.08 in)

09900-20805: Tire depth gauge

### TIRE PRESSURE

If the tire pressure is too high or too low, steering will be adversely affected and tire wear increased. Therefore, maintain the correct tire pressure for good roadability or shorter tire life will result. Cold inflation tire pressure is as follows.

	Solo riding			Dual riding		
	kPa	kg/cm <sup>2</sup>	psi	kPa	kg/cm <sup>2</sup>	psi
FRONT	200	2.00	29	200	2.00	29
REAR	225	2.25	33	250	2.50	36

### CAUTION:

The standard tire fitted on this motorcycle is 110/70-17 54H for front and 140/70-17 66H for rear. The use of a tire other than the standard may cause instability. It is highly recommended to use a SUZUKI Genuine Tire.

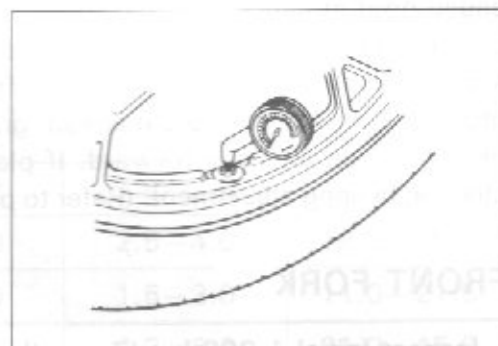
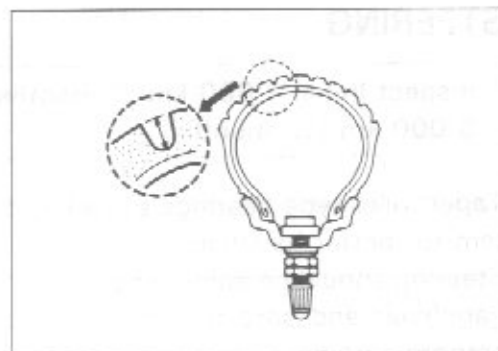

## STEERING

**Inspect Initial 1 000 km (2 months) and Every  
5 000 km (15 months)**

Taper roller type bearings are applied on the steering system for better handling.

Steering should be adjusted properly for smooth turning of handlebar and safe running. Too stiff steering prevents smooth turning of handlebar and too loose steering will cause poor stability.

Check that there is no play in the front fork assembly by supporting the machine so that the front wheel is off the ground, with wheel straight ahead, grasp lower fork tubes near the axle and pull forward. If play is found, perform steering bearing adjustment. (Refer to pages 7-25 and 7-26.)



## FRONT FORK

**Inspect Initial 1 000 km (2 months) and Every  
5 000 km (15 months)**

Inspect the front fork for oil leakage, scoring and scratches on the outer surface of the inner tubes.

Replace any defective parts, if necessary.

## REAR SUSPENSION

**Inspect Initial 1 000 km (2 months) and Every  
5 000 km (15 months)**

Inspect the rear shock absorber for oil leakage and check that there is no play in the swingarm assembly.

## CHASSIS BOLTS AND NUTS

Tighten Initial 1 000 km (2 months) and Every  
5 000 km (15 months)

The bolts and nuts listed below are important safety parts. They must be retightened when necessary to the specified torque.

ITEM	N·m	kg·m	lb·ft
① Steering stem head bolt	35–55	3.5–5.5	25.5–40.0
② Handlebar clamp bolt	18–28	1.8–2.8	13.0–20.0
③ Handlebar holder bolt	40–60	4.0–6.0	29.0–43.5
④ Handlebar holder nut	27–42	2.7–4.2	19.5–30.5
⑤ Front fork upper clamp bolt	18–28	1.8–2.8	13.0–20.0
⑥ Front fork lower clamp bolt	25–40	2.5–4.0	18.0–29.0
⑦ Front fork cap	15–30	1.5–3.0	11.0–21.5
⑧ Front axle nut	43–62	4.3–6.2	31.0–45.0
⑨ Front axle pinch bolt	20–30	2.0–3.0	14.5–21.5
⑩ Front brake master cylinder bolt	5–8	0.5–0.8	3.5–6.0
⑪ Brake hose union bolt (Front & Rear)	15–20	1.5–2.0	11.0–14.5
⑫ Brake disc bolt (Front & Rear)	18–28	1.8–2.8	13.0–20.0
⑬ Air bleeder valve (Front & Rear)	6–9	0.6–0.9	4.5–6.5
⑭ Front brake caliper mounting bolt	30–47	3.0–4.7	21.5–34.0
⑮ Rear axle nut	55–88	5.5–8.8	40.0–63.5
⑯ Rear torque link nut	25–38	2.5–3.8	18.0–27.5
⑰ Rear brake caliper mounting bolt	20–30	2.0–3.0	14.5–21.5
⑱ Rear brake caliper housing bolt	30–36	3.0–3.6	21.5–26.0
⑲ Rear brake master cylinder bolt	8–12	0.8–1.2	6.0–8.5
⑳ Rear brake rod lock nut	15–20	1.5–2.0	11.0–14.5
㉑ Rear shock absorber mounting nut (Upper & Lower)	48–72	4.8–7.2	34.5–52.0
㉒ Rear cushion lever nut (Front)	84–120	8.4–12.0	60.5–87.0
㉓ Rear cushion lever nut (Center)	84–120	8.4–12.0	60.5–87.0
㉔ Rear cushion rod nut	84–120	8.4–12.0	60.5–87.0
㉕ Rear swingarm pivot nut	55–88	5.5–8.8	40.0–63.5

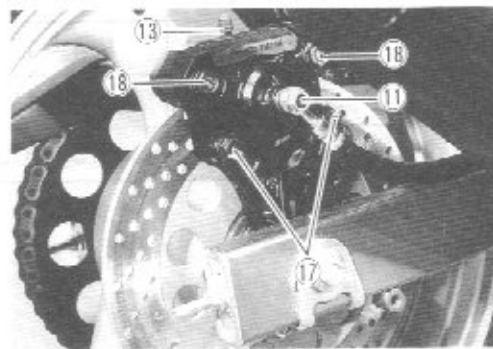
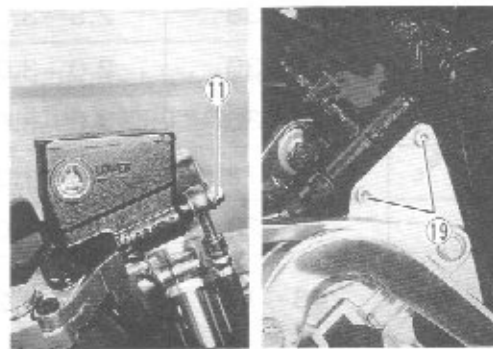
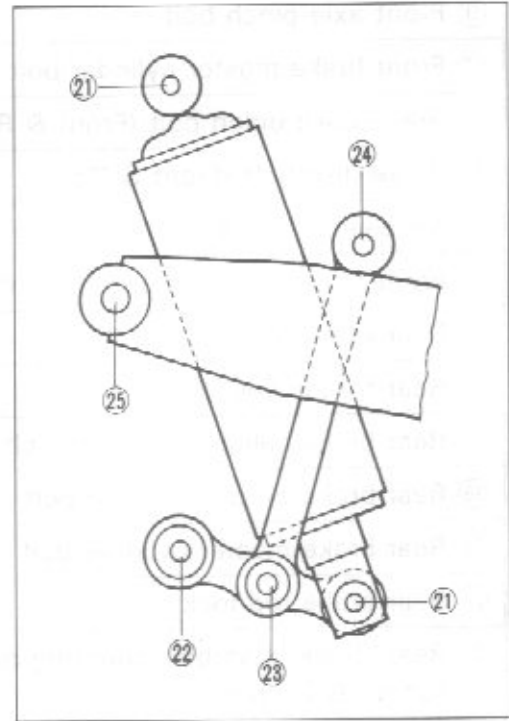
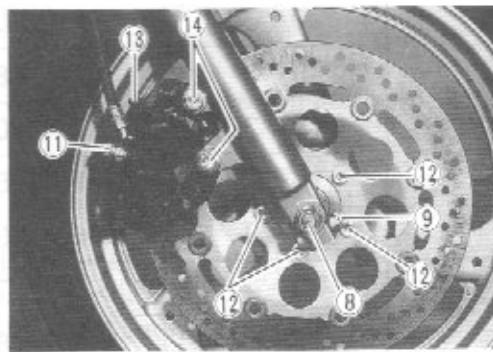
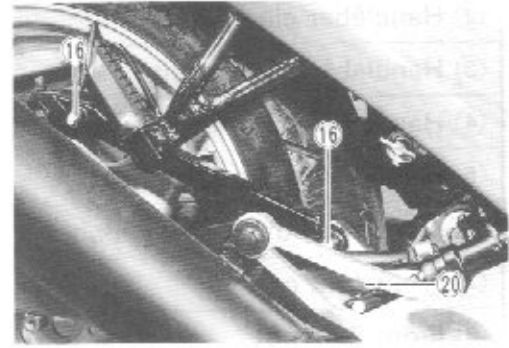
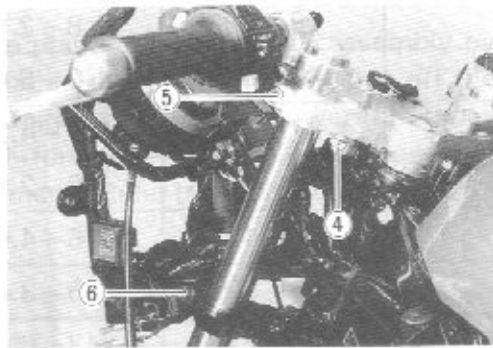
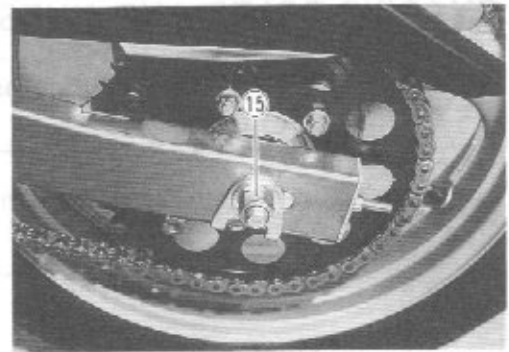
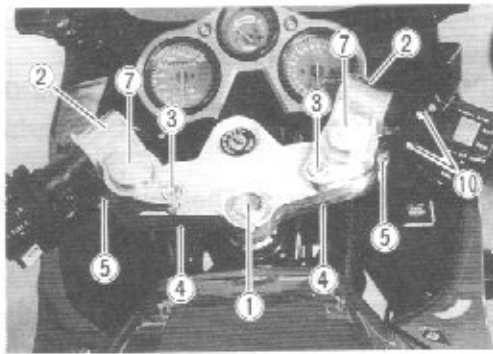

# ENGINE

## CONTENTS

<b>COMPRESSION PRESSURE CHECK</b> .....	<b>3- 1</b>
<b>COMPRESSION TEST PROCEDURE</b> .....	<b>3- 1</b>
<b>OIL PRESSURE CHECK</b> .....	<b>3- 2</b>
<b>OIL PRESSURE TEST PROCEDURE</b> .....	<b>3- 2</b>
<b>ENGINE COMPONENTS REMOVABLE WITH ENGINE IN PLACE</b> .....	<b>3- 3</b>
<b>ENGINE REMOVAL AND REMOUNTING</b> .....	<b>3- 4</b>
<b>ENGINE REMOVAL</b> .....	<b>3- 4</b>
<b>ENGINE REMOUNTING</b> .....	<b>3- 8</b>
<b>ENGINE DISASSEMBLY</b> .....	<b>3- 9</b>
<b>ENGINE COMPONENTS INSPECTION AND SERVICING</b> .....	<b>3-18</b>
<b>CYLINDER HEAD</b> .....	<b>3-18</b>
<b>VALVE</b> .....	<b>3-19</b>
<b>CAMSHAFT</b> .....	<b>3-23</b>
<b>CAM CHAIN TENSIONER</b> .....	<b>3-25</b>
<b>CYLINDER</b> .....	<b>3-25</b>
<b>PISTON</b> .....	<b>3-26</b>
<b>PISTON RING</b> .....	<b>3-27</b>
<b>PISTON PIN</b> .....	<b>3-28</b>
<b>CONROD</b> .....	<b>3-28</b>
<b>CRANKSHAFT</b> .....	<b>3-31</b>
<b>CLUTCH</b> .....	<b>3-35</b>
<b>OIL PUMP</b> .....	<b>3-36</b>
<b>TRANSMISSION GEARS</b> .....	<b>3-36</b>
<b>ENGINE REASSEMBLY</b> .....	<b>3-39</b>

## COMPRESSION PRESSURE CHECK

The compression of a cylinder is a good indicator of its internal condition.

The decision to overhaul the cylinder is often based on the results of a compression test. Periodic maintenance records kept at your dealership should include compression readings for each maintenance service.

### COMPRESSION PRESSURE SPECIFICATION

Standard	Limit	Difference
1 200–1 700 kPa (12–17 kg/cm <sup>2</sup> ) (171–241 psi)	1 000 kPa (10 kg/cm <sup>2</sup> ) (142 psi)	200 kPa (2 kg/cm <sup>2</sup> ) (28 psi)

**Low compression pressure can indicate any of the following conditions:**

- \* Excessively worn cylinder wall
- \* Worn-down piston or piston rings
- \* Piston rings stuck in the grooves
- \* Poor seating of valves
- \* Ruptured or otherwise defective cylinder head gasket

**Overhaul the engine in the following cases:**

- \* Compression pressure in one of the cylinders is less than 1 000 kPa (10 kg/cm<sup>2</sup>, 142 psi).
- \* Difference in compression pressure between any two cylinders is more than 200 kPa (2 kg/cm<sup>2</sup>, 28 psi).
- \* All compression pressure are below 1 200 kPa (12 kg/cm<sup>2</sup>, 171 psi) even when they measure more than 1 000 kPa (10 kg/cm<sup>2</sup>, 142 psi).

### COMPRESSION TEST PROCEDURE

#### NOTE:

- \* *Before testing the engine for compression pressure, make sure that the cylinder head nuts and bolts are tightened to the specified torque values and tappet clearance are properly adjusted.*
- \* *Have the engine warmed up by idling before testing.*

Remove the parts concerned and test the compression pressure in the following manner.

- Remove the seat.
- Pull up the trunk.
- Remove all the spark plugs.
- Fit the compression gauge ① one of the plug holes, taking care to make the connection tight.
- Keep the throttle grip in full-open position.
- While cranking the engine a few seconds with the starter, record the maximum gauge reading as the compression of that cylinder.
- Repeat this procedure with the other cylinders.

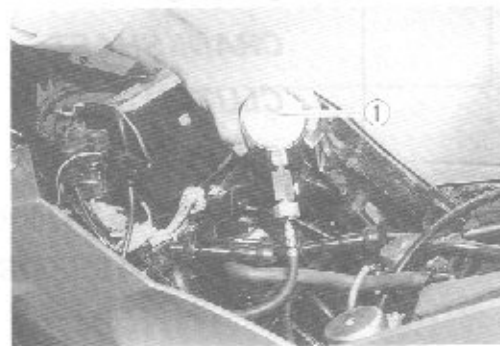

09915-64510: Compression gauge

09915-63310: Adaptor

## OIL PRESSURE CHECK

To check periodically oil pressure of the oil passage way in the engine needs to judge roughly the conditions of the moving parts.

### OIL PRESSURE SPECIFICATION

<p><b>Above 200 kPa (2.0 kg/cm<sup>2</sup>, 28 psi)</b>  <b>Below 400 kPa (4.0 kg/cm<sup>2</sup>, 57 psi)</b></p>	<p><b>at 3 000 r/min., Oil temp. at 60°C (140°F)</b></p>
---	--

If the oil pressure is lower or higher than the specification, the following causes may be considered.

### LOW OIL PRESSURE

- \* Clogged oil filter
- \* Oil leakage from oil passage way
- \* Damaged oil seal
- \* Defective oil pump
- \* Combination of above items

### HIGH OIL PRESSURE

- \* Used a engine oil which is too heavy a weight
- \* Clogged oil passage way
- \* Combination of above items

## OIL PRESSURE TEST PROCEDURE

Start the engine and check if the oil pressure indicator light is turned on. If it keeps on lighting, check the oil pressure indicator light circuit. If it is in good condition, check the oil pressure in the following manner.

- Remove the lower cowling.
- Install the oil pressure gauge (1) with the adaptor in the position shown in the figure.
- Warm up the engine as follows:  
 Summer 10 min. or so at 2 000 r/min.  
 Winter 20 min. or so at 2 000 r/min.
- After warming up, increase the engine speed to 3 000 r/min. with the engine tachometer reading, and read the oil pressure gauge.

09915-74520: Oil pressure gauge

09915-77330: Compression gauge

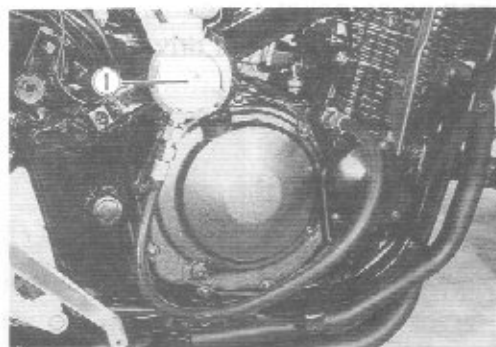



## ENGINE COMPONENTS REMOVABLE WITH ENGINE IN PLACE

The parts listed below can be removed and reinstalled without removing the engine from the frame. Refer to the page listed in each section for removal and reinstallation instructions.

### ENGINE CENTER

	See page
Exhaust pipe/muffler .....	3-6
Radiator .....	5-3
Water hose .....	3-5
Oil filter .....	2-9
Oil strainer .....	3-15
Oil regulator .....	3-15
Carburetor .....	3-6
Cam chain tensioner .....	3-9
Cylinder head cover .....	3-9
Camshafts .....	3-9
Cylinder head .....	3-10
Cylinder .....	3-10
Pistons .....	3-11
Starter motor .....	3-11

### ENGINE LEFT SIDE

	See page
Engine sprocket cover .....	3-7
Engine sprocket and drive chain .....	3-7
Generator cover .....	3-14
Starter clutch .....	3-14
Starter idle gear .....	3-14

### ENGINE RIGHT SIDE

	See page
Signal generator cover .....	3-9
Signal generator .....	3-11
Oil pressure switch .....	3-11
Clutch cover .....	3-11
Clutch pressure, drive and driven plate .....	3-11
Oil pump driven gear .....	3-12
Primary driven gear .....	3-12
Gearshift shaft .....	3-13
Gear shifting pawl and cam driven gear .....	3-13
Neutral indicator switch body .....	3-13
Oil pump .....	3-12
Water pump .....	5-9

## ENGINE REMOVAL AND REMOUNTING

### ENGINE REMOVAL

Before taking the engine out of the frame, thoroughly clean the engine with a suitable cleaner. The procedure of engine removal is sequentially explained in the following steps.

- Drain engine oil. (Refer to page 2-8.)
- Drain coolant. (Refer to page 2-11.)
- Remove the seat.
- Remove the trunk mounting bolts and screws. (Refer to page 2-3.)
- Remove the trunk by removing the clip (1) and pin (2).
- Open the fuel tank cap lid by turning the ignition switch key to the "FUEL" position and then push the fuel opener (3).

#### NOTE:

To open the fuel tank cap lid when the battery is discharged, unhook the lid latch (4) by hand as shown in the illustration.

- Remove the frame covers by removing the mounting screws (5), (6) and (7).
- Remove the fairing. (Refer to page 7-1.)
- Remove the radiator. (Refer to page 5-3.)
- Remove the battery by disconnecting the  $\ominus$  and  $\oplus$  battery lead wires.

#### WARNING:

When disconnecting the battery lead wires,  $\ominus$  lead wire first.

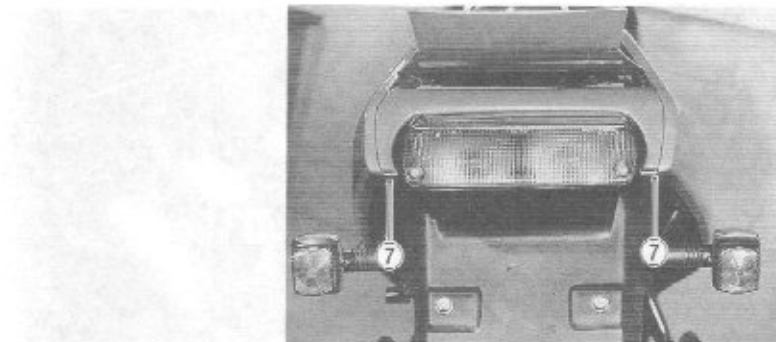
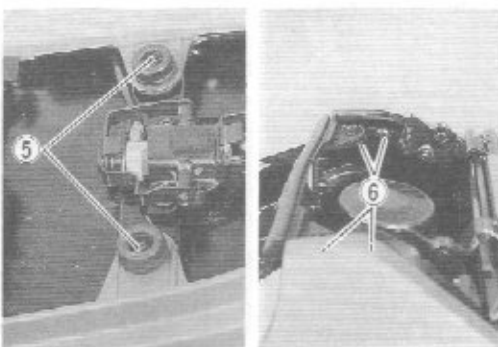
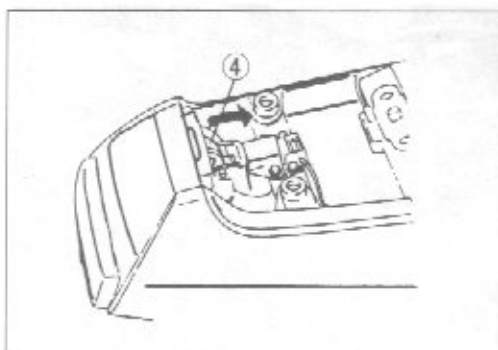
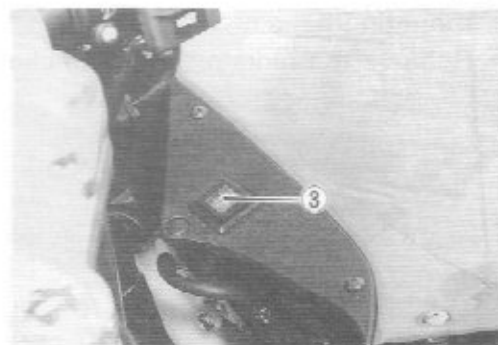
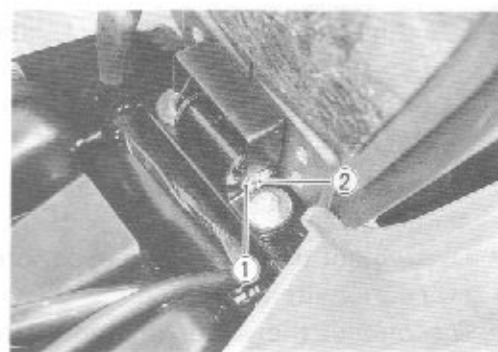

- Disconnect the fuse coupler (1), starter relay coupler (2) and starter motor wire (3).
- Remove the battery holder (4), by removing the mounting bolts.
- Remove the rubber covers (5) and (6), by removing the clamps.
- Disconnect the spark plug caps, breather hose and radiator fan switch lead wire.
- Disconnect the water thermo switch lead wire (7).
- Remove the water thermo case (8) by removing the mounting bolts.
- Remove the radiator lower bracket (9).

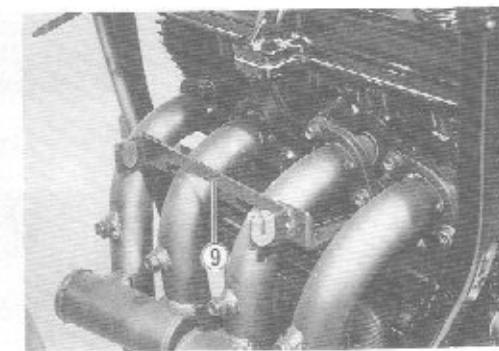
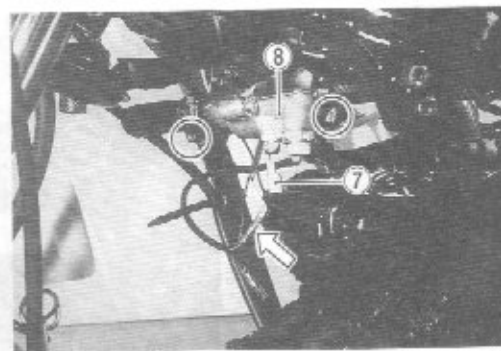
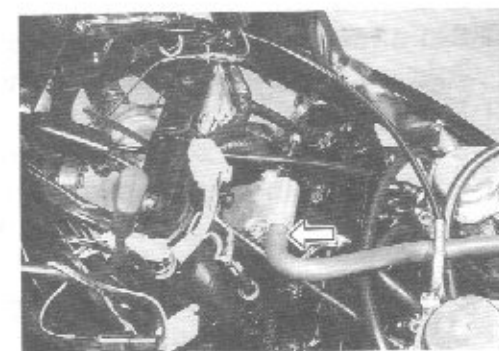
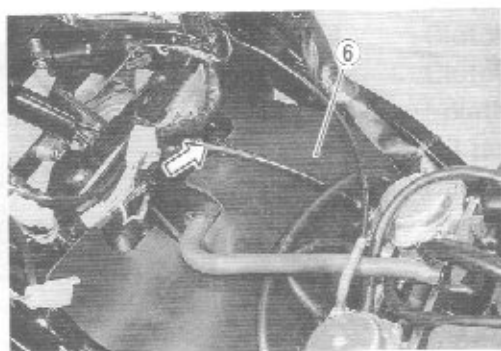
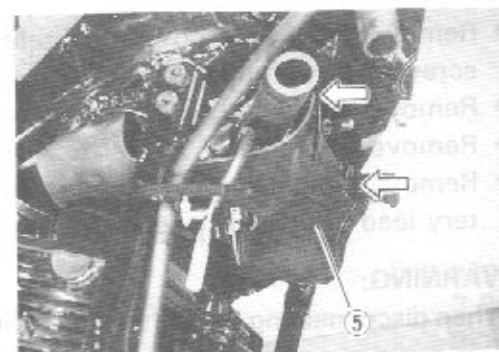
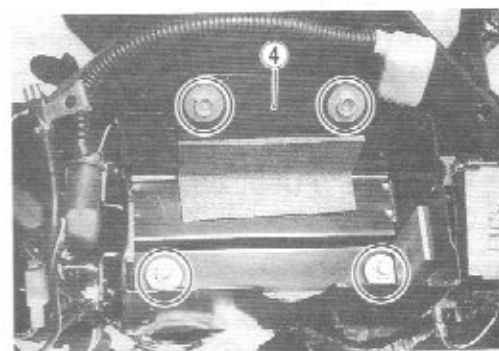
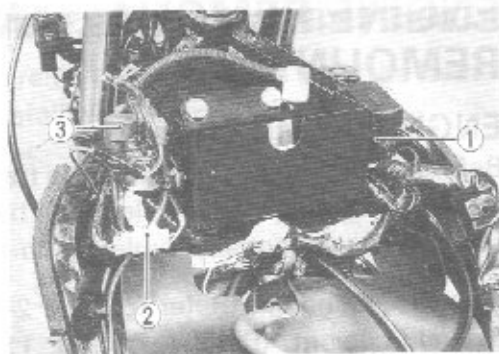

- Remove the exhaust pipe bolts (1).
- Remove the muffler by removing the mounting nut and bolt.
- Remove the starter cables (2).
- Remove the air cleaner mounting bolts (3).
- Remove the air cleaner by loosening the clamp screws.
- Remove the carburetors by loosening the clamp screws.
- Disconnect the throttle cable (4) by loosening the lock nuts.
- Disconnect the starter motor lead wire (5), oil pressure switch lead wire (6) and ground wire (7).
- Disconnect the signal generator lead wires, generator lead wires and neutral indicator switch lead wire.

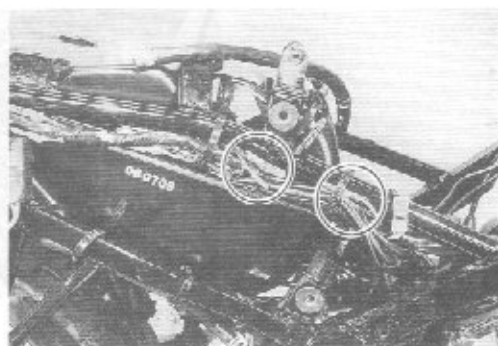
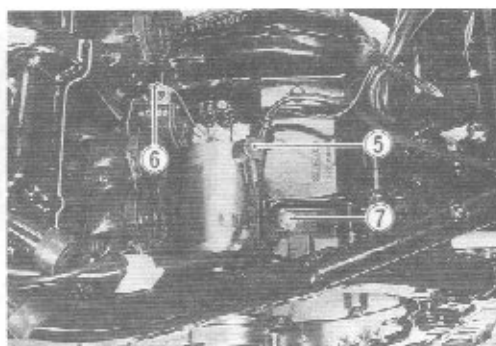
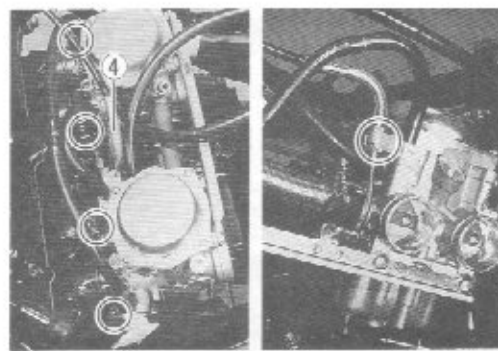
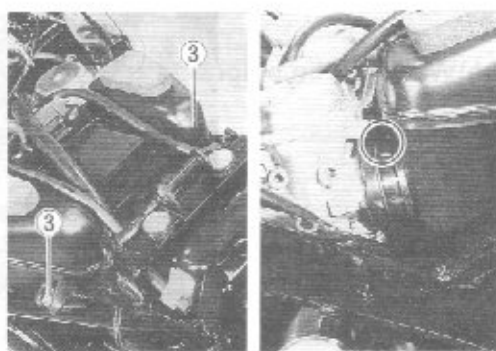
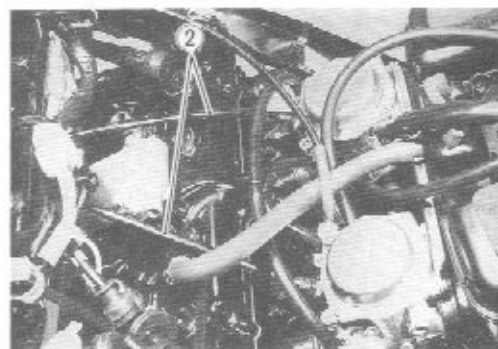
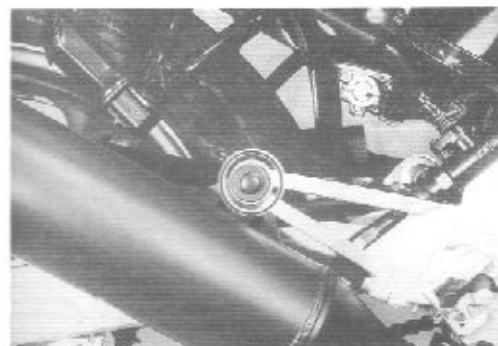
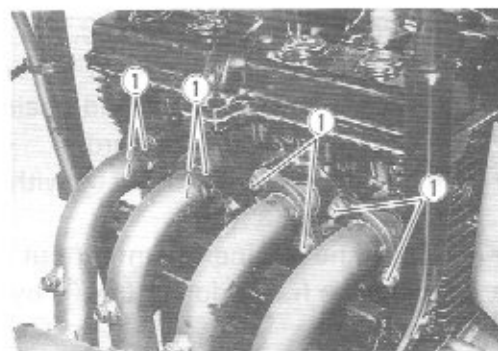

- Remove the gearshift arm ①.
- Remove the engine sprocket cover.
- Loosen the rear axle nut and chain adjuster nuts.
- Push the rear wheel forward.
- Remove the engine sprocket ② with drive chain by removing the circlip ③.
- Remove the engine mounting nut and bolt ④.
- Remove the frame down tube ⑤ by removing the mounting bolts ⑥.
- Remove the other engine mounting nuts and bolts ⑦.
- Remove the engine by using jack etc.

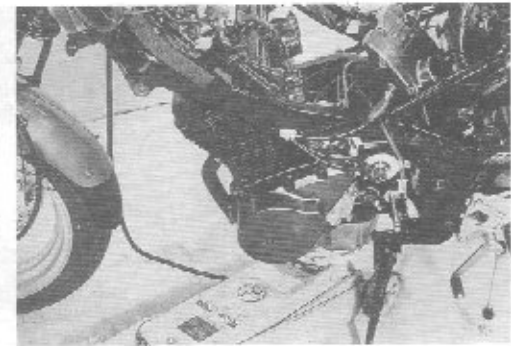
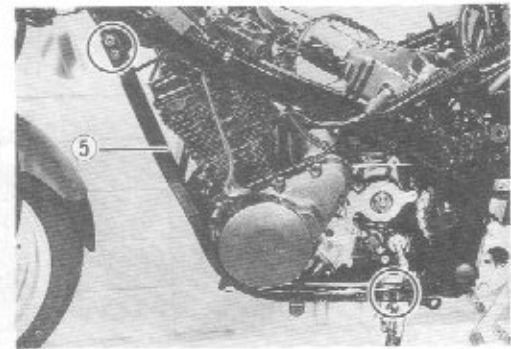
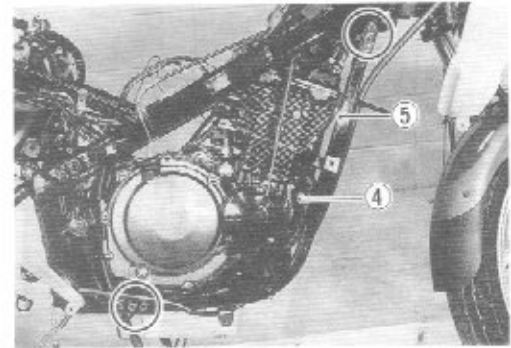
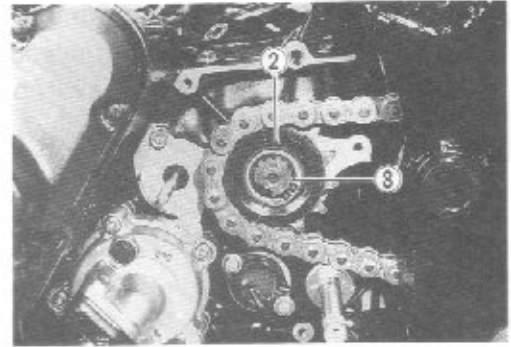
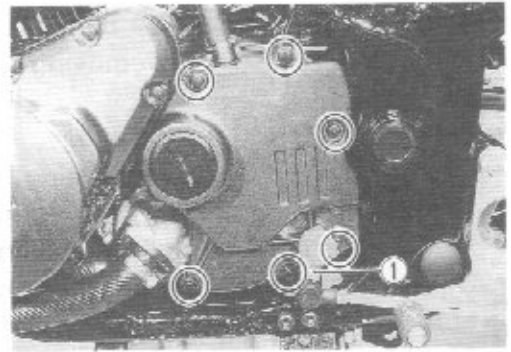
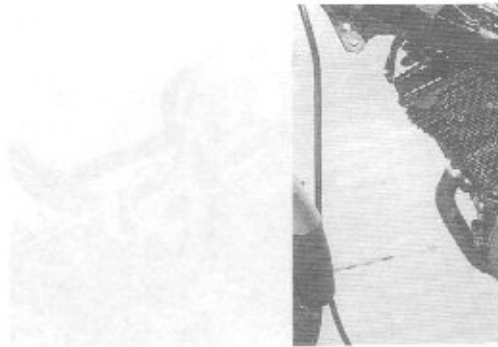

## ENGINE REMOUNTING

The engine can be mounted in the reverse order of removal.

### NOTE:

The engine mounting nuts are self-lock type. Once the nut has been removed, it is no longer of any use. Be sure to use new nuts and tighten them to the specified torque.

### Tightening torque

ITEM	N·m	kg·m	lb·ft
①, ②, ③	60–72	6.0–7.2	43.5–52.0
④	18–28	1.8–2.8	13.0–20.0

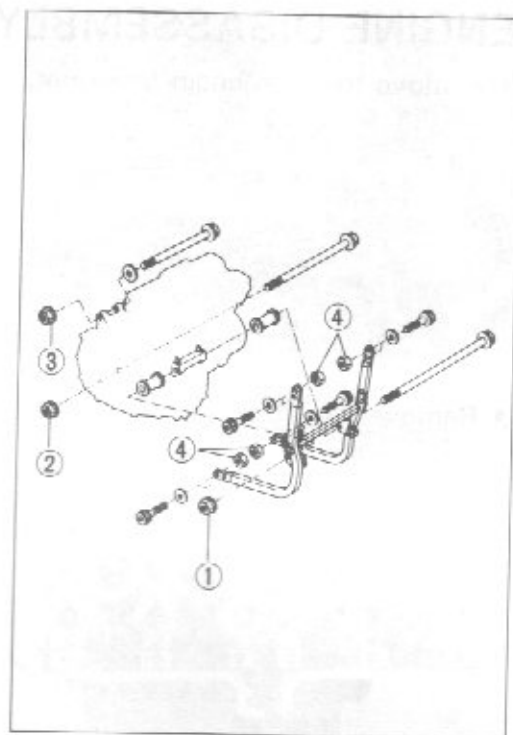

- Tighten the exhaust pipe bolts ⑤ and muffler mounting nut ⑥ to the specified torque.

### Tightening torque

- ⑤: 8–12 N·m (0.8–1.2 kg·m, 6.0–8.5 lb·ft)
- ⑥: 18–28 N·m (1.8–2.8 kg·m, 13.0–20.0 lb·ft)

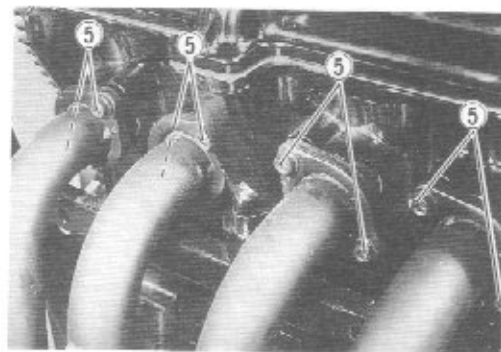

## ENGINE OIL

Pour 3.2 L (3.4/2.8 US/Imp qt) of engine oil SAE10W/40 under API classification.

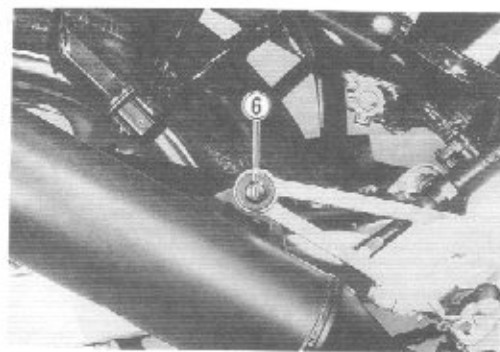

## ADJUSTMENT

After remounting the engine, following adjustments are necessary.

- \* Throttle cable play
- \* Clutch cable play
- \* Drive chain slack
- \* Engine idle r/min
- \* Filling cooling solution

## ENGINE DISASSEMBLY

- Remove the cam chain tensioner.

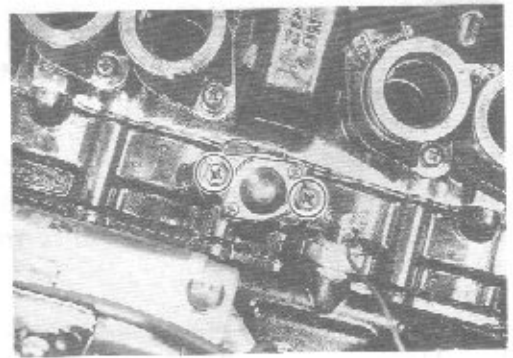

- Remove the signal generator cover.

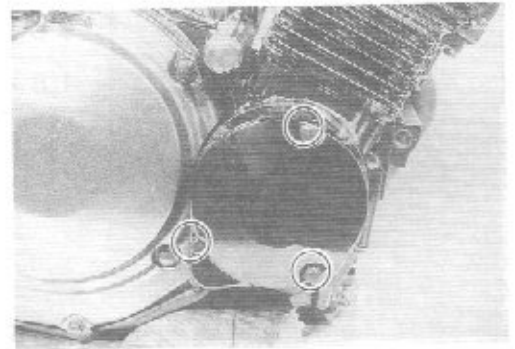

- Remove the cylinder head cover.

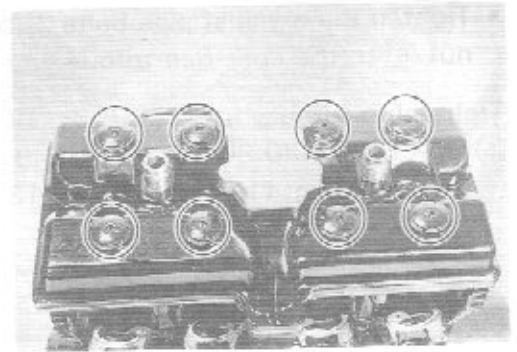

- Remove the camshaft journal holders.

**NOTE:**

*Be sure to loosen the camshaft journal holder bolts evenly by shifting the wrench diagonally.*

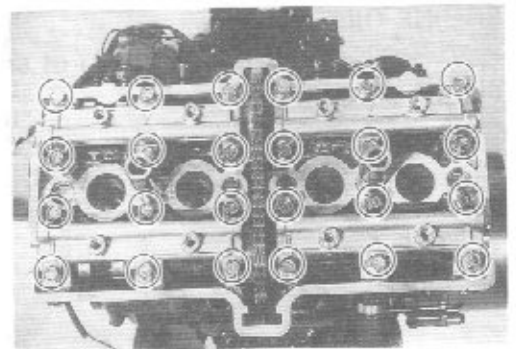

- Remove the camshafts and cam chain guide ①.

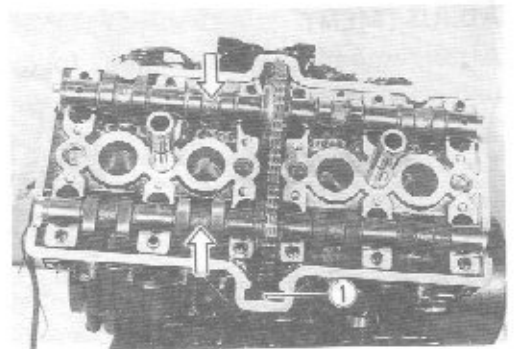

- The cylinder head becomes free for removal when its one 6-mm bolt (A) and twelve 10-mm nuts are removed.

**NOTE:**

*When loosening the cylinder head nuts, loosen each nut little by little in a descending order according to the numbers cast on a cylinder head.*

- Lift the cylinder head up to grip its both ends. If it does not come off, lightly tap on the finless portions of it with a plastic mallet.

**CAUTION:**

**Be careful not to damage the fins when removing or handling the cylinder head.**

- Remove the hose.

- Firmly grip both ends of the cylinder block and lift it straight up. If the block does not come off, lightly tap on the finless portions of the block with a plastic mallet to shake the gasketed joint loose.

**CAUTION:**

**Be careful not to damage the fins when removing or handling the cylinder block.**

- Scribe the cylinder number on the head of the respective pistons.

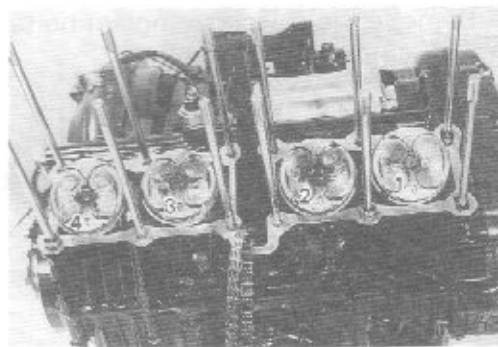
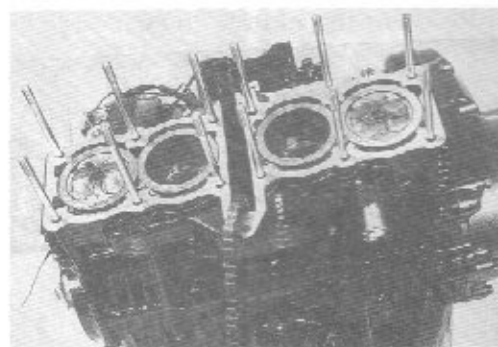
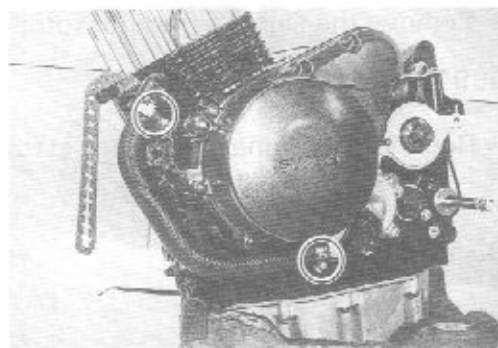
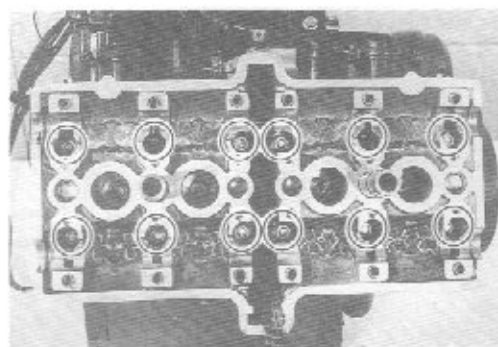
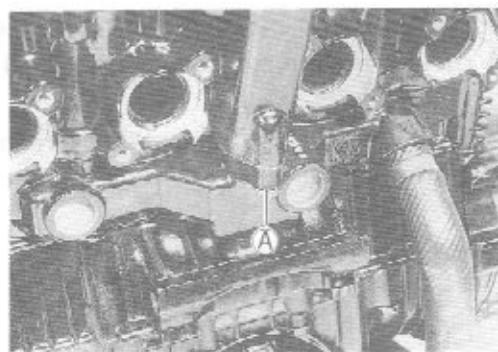



- Place a cloth beneath the piston so as not to drop any parts in the crankcase, and remove the circlip ① with long-nose pliers.
- Draw out the piston pin. Place each piston pin in the same piston as that it was removed from.

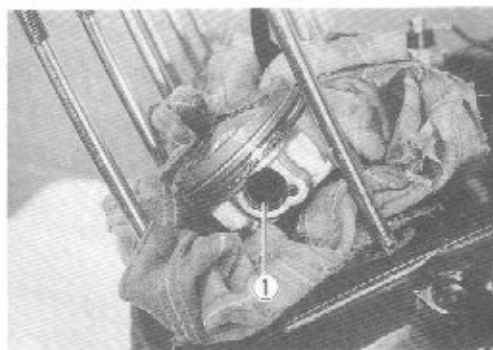

- Remove the starter motor ② and oil pressure switch ③.

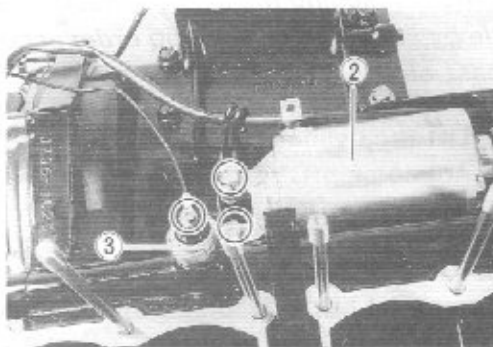

- Remove the signal generator rotor with the special tool.

**09910-20115: Conrod holder**

- Remove the signal generator stator.

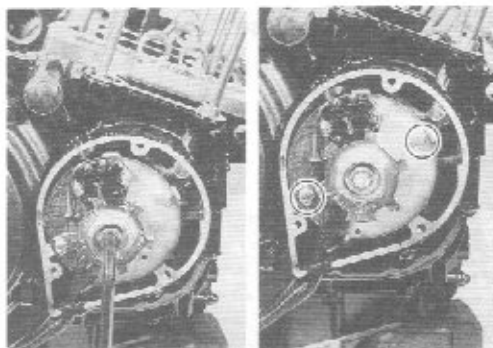

- Remove the clutch cover.

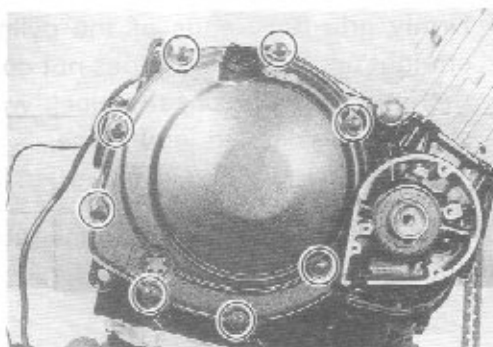

- Remove the clutch spring set bolts in a criss-cross manner with the special tool.

**09910-20115: Conrod holder**

- Remove the drive and driven plates.

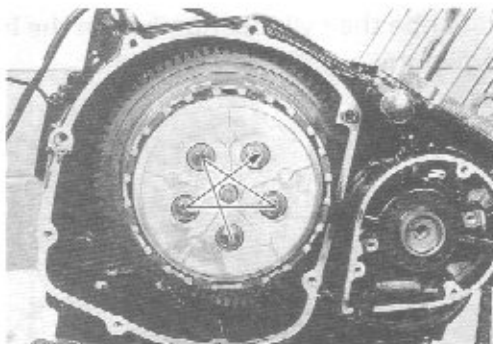

- Remove the push piece ① and bearing.
- Remove the push rod ②.

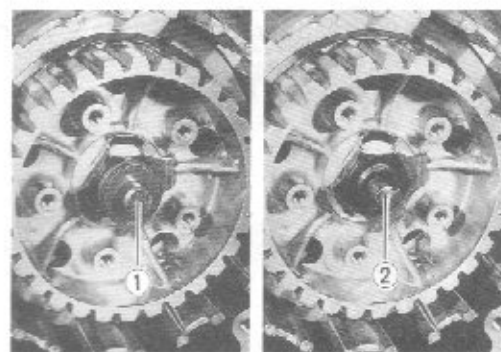

- Flatten the lock washer, and remove the clutch sleeve hub nut with the special tool.

**09920-53710: Clutch sleeve hub holder**

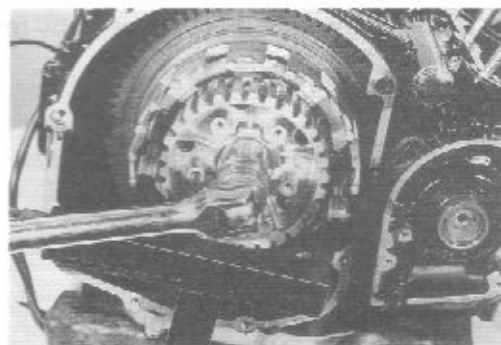

- Remove the thrust washer ③.
- Remove the primary driven gear spacer ④ with the special tool.

**09900-06108: Snap ring pliers**

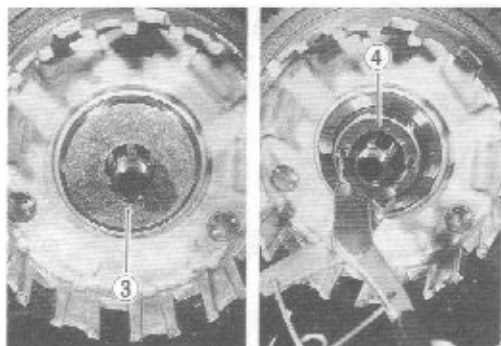
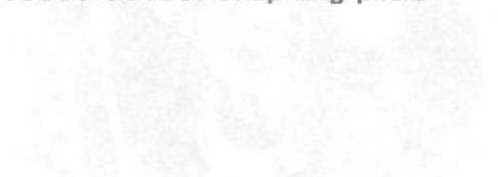

- Remove the bearing ⑤ and primary driven gear.
- Remove the thrust washers ⑥ and ⑦).

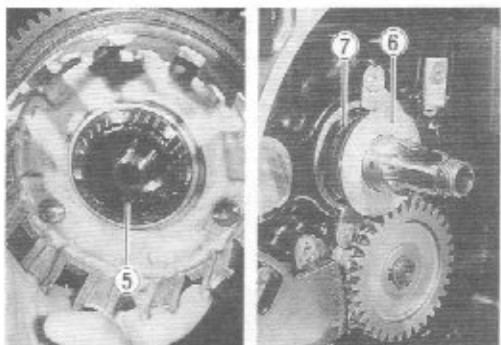

- Remove the oil pump driven gear by removing the circlip ⑧.
- Remove the oil pump ⑨.

**NOTE:**

*Do not loose the pin ⑩.*

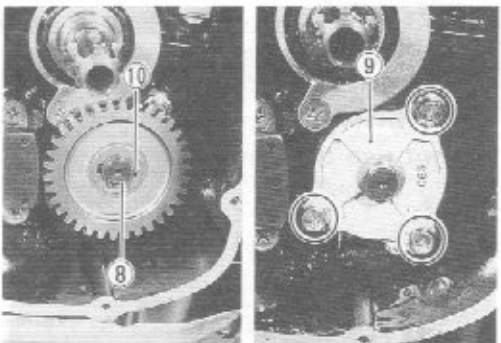
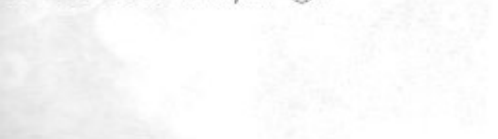

- Remove the gearshift shaft (1) by removing the circlip (2).

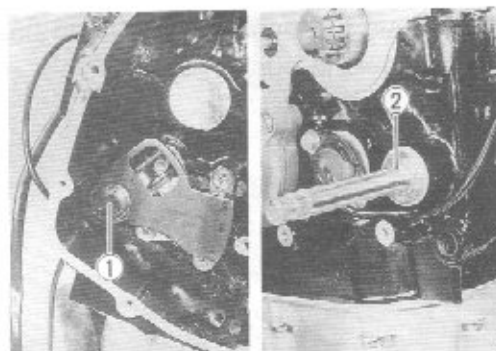

- Remove the cam driven gear (3) by removing the pawl lifter (4) and cam guide (5).

**NOTE:**

When removing the cam driven gear, do not lose the gearshift pawl (6), pin (7) and spring (8).

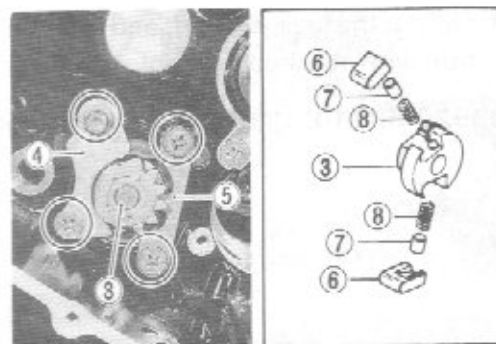
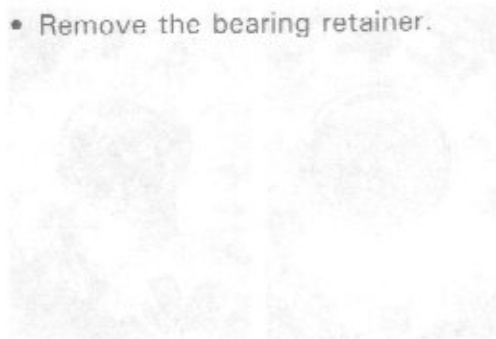

- Remove the bearing retainer.

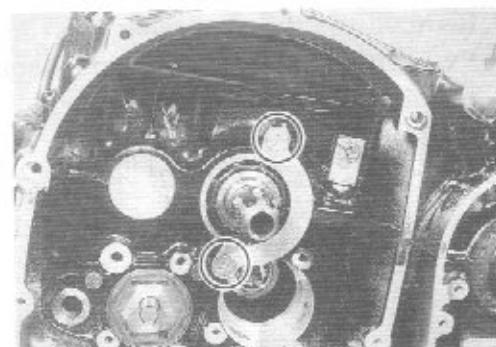

- Remove the neutral indicator switch.
- Remove the O-ring (9), contact (10) and spring (11).

**CAUTION:**

Do not use the removed O-ring.

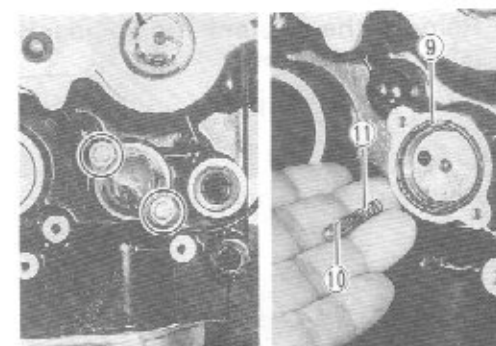
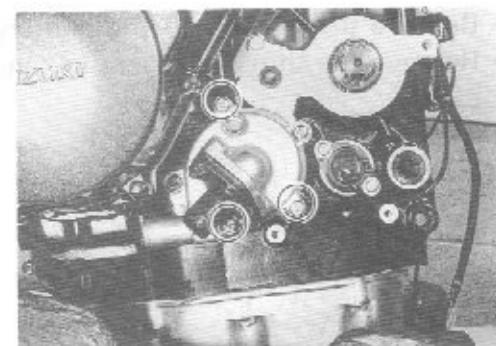

- Flatten the lock portion of the oil seal retainer and remove it.

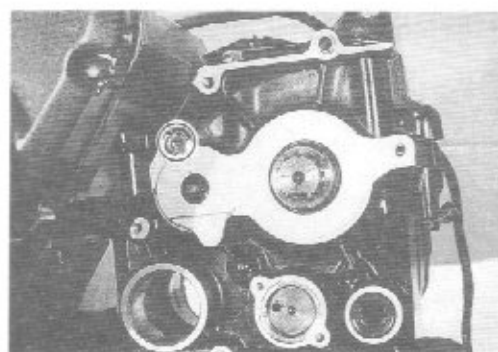

- Remove the generator cover.

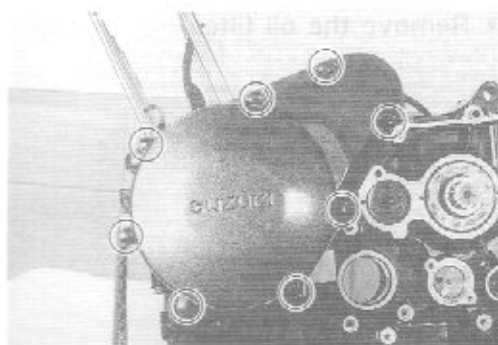

- Remove the starter idle gear (1) by removing the shaft (2).

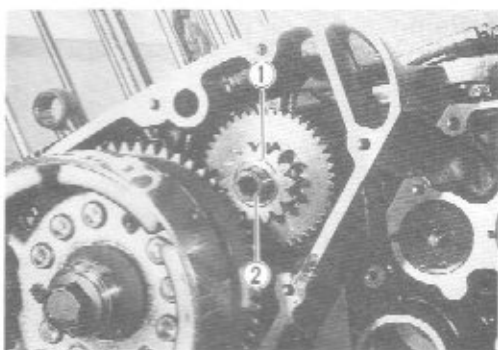

- Remove the generator rotor bolt with the special tool.

**09930-44913: Rotor holder**

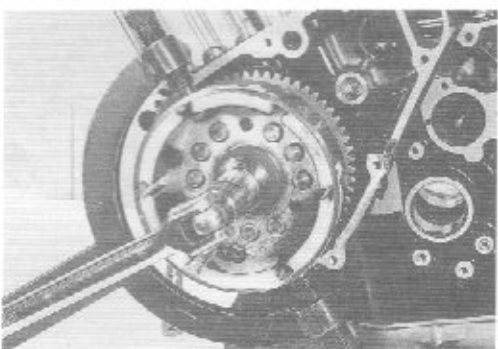

- Remove the generator rotor with the rotor bolt (3) and special tool.

**09930-30180: Rotor remover**

**CAUTION:**

**Do not hit the rotor when removing the rotor.**

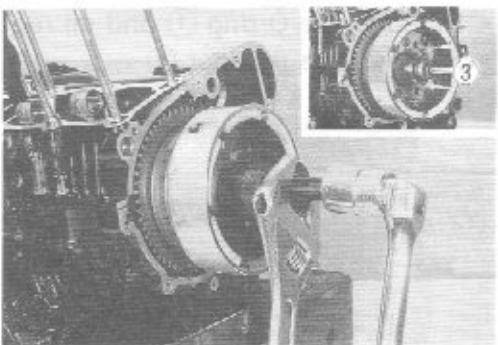

- Remove the oil filter cap.

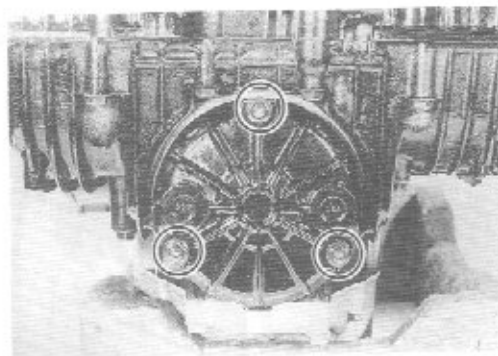

- Remove the oil filter.

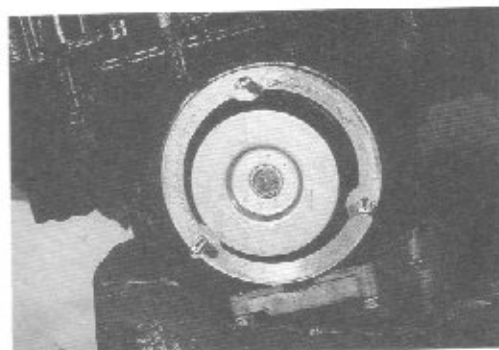

- Remove the oil pan.

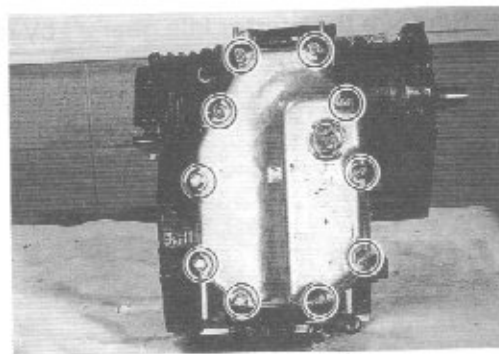

- Remove the oil strainer.

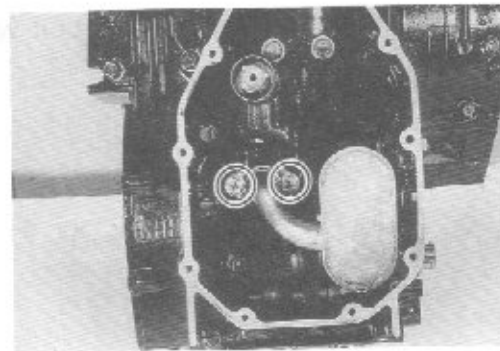

- Remove the O-ring (1) and oil regulator (2).
- Remove the retainer (3).

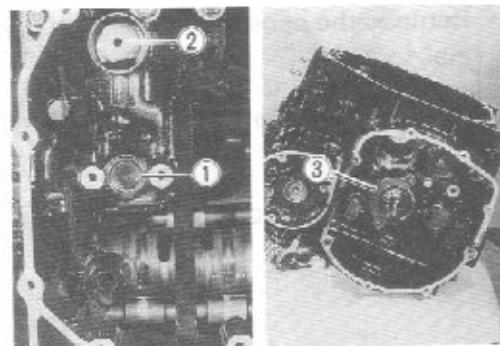

- Remove the upper crankcase securing bolts.

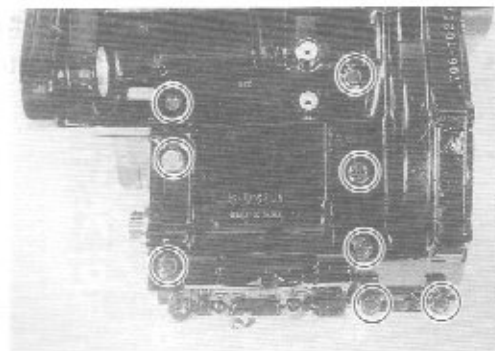

- Remove the lower crankcase securing bolts.
- When removing the crankshaft tightening bolts, loosen them in the descending order of numbers assigned to these bolts.

**NOTE:**

Two allen bolts are used for tightening crankshaft at the portion (A).

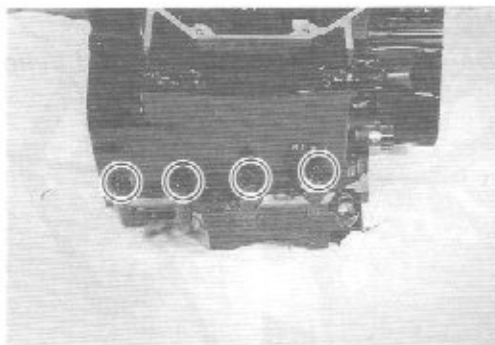
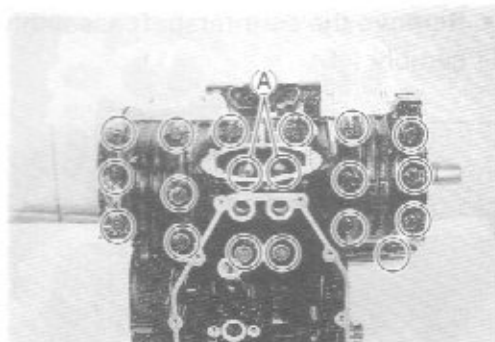

- Make sure that all bolts are removed without fail.
- Separate the upper and lower crankcases with the special tool.

**CAUTION:**

Do not drop the crankshaft journal bearings from the lower crankcase.

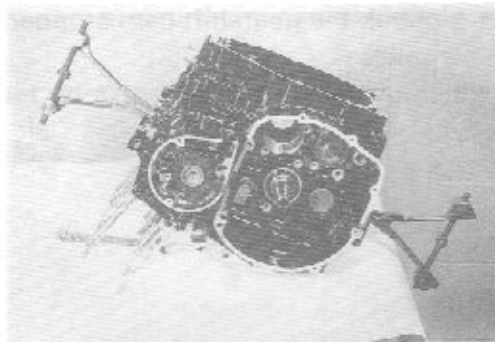

- Remove the crankshaft assembly from the upper crankcase.

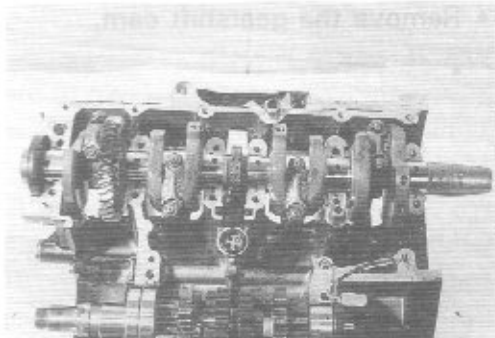

- Remove the two dampers (1) and cam chain guide (2).
- Remove the O-ring (3) and oil plate (4).

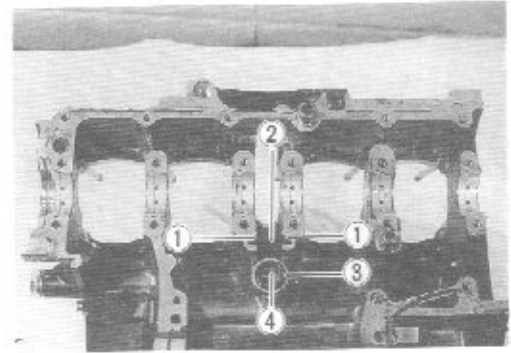

- Remove the countershaft assembly (5) and driveshaft assembly (6).

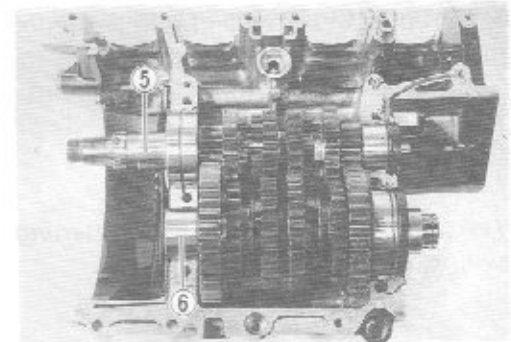

**NOTE:**

Do not lose the C-rings (7) and bearing pins (8).

- Unhook the gearshift cam stopper spring from the lower crankcase.
- Remove the gearshift forks by removing the shaft.

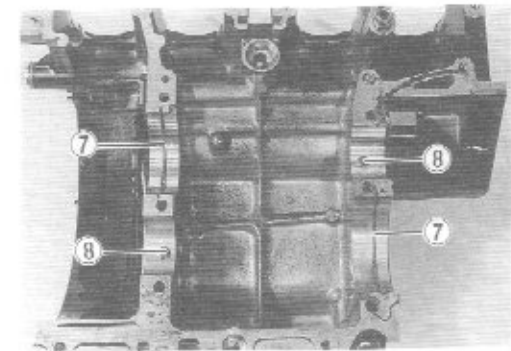

- Remove the gearshift cam.

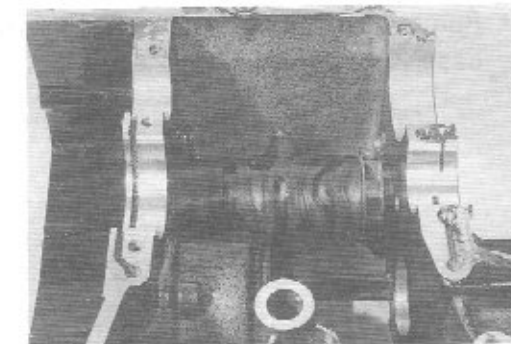
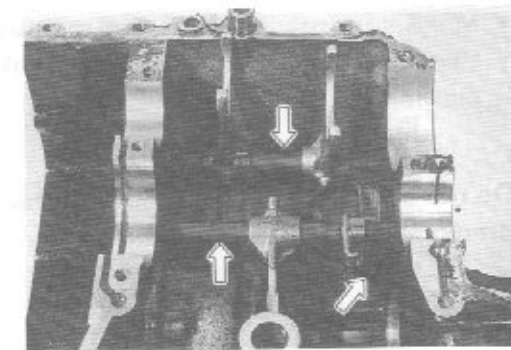

# ENGINE COMPONENTS INSPECTION AND SERVICING

## CYLINDER HEAD

### CAUTION:

Be sure to identify each removed part as to its location, and lay the parts out in groups designated as "No.1", "No.2", "Exhaust", "Inlet", so that each will be restored to the original location during assembly.

- Remove the 16 tappets (1).
- Remove the 16 shims (2).

- Remove the two cotter halves (3) by compressing the valve spring with the special tools.

09916-14510: Valve spring compressor

09916-14530: Attachment

09916-84510: Tweezers

- Remove the spring retainer and spring.

- Remove the valve.

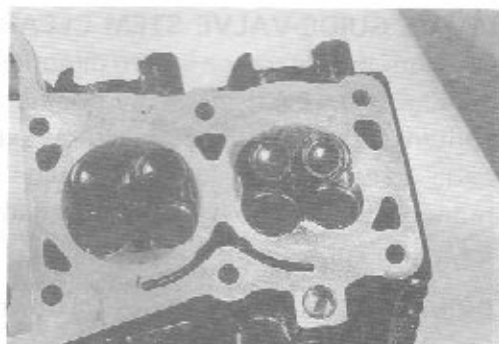
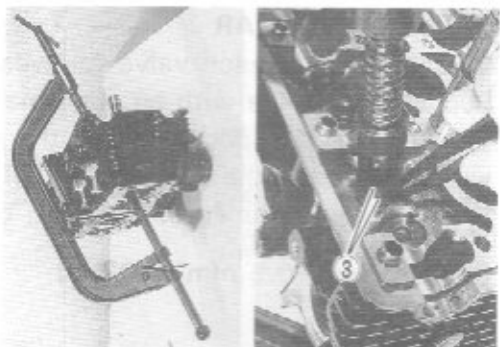
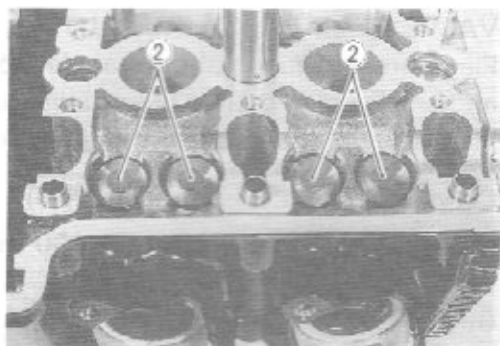
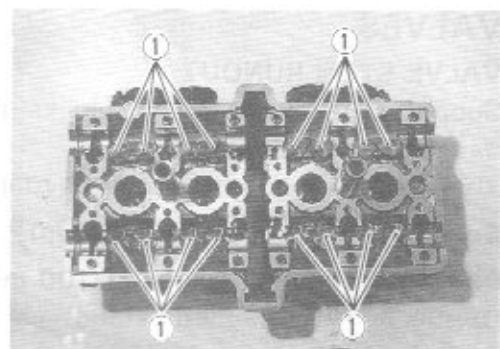

### CYLINDER HEAD DISTORTION

Decarbonize the combustion chambers.

Check the gasketed surface of the cylinder head for distortion with a straight edge and thickness gauge, taking a clearance reading at several places indicated. If the largest reading at any position of the straight edge exceeds the limit, replace the cylinder head.

**Service Limit: 0.20 mm (0.008 in)**



## VALVES

### VALVE STEM RUNOUT

Support the valve with "V" blocks, as shown, and check its runout with a dial gauge.

The valve must be replaced if the runout exceeds the limit.

**Service Limit: 0.05 mm (0.002 in)**

09900-20606: Dial gauge (1/100 mm)

09900-20701: Magnetic stand

09900-21304: V-block (100 mm)

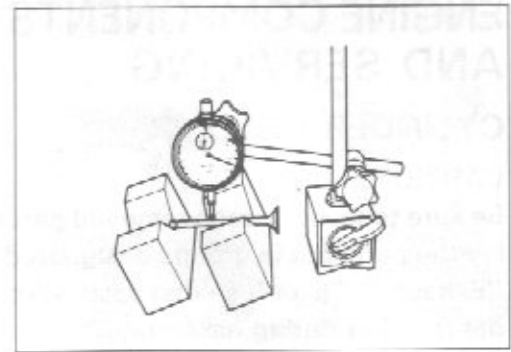

### VALVE HEAD RADIAL RUNOUT

Place the dial gauge at right angles to the valve head face, and measure the valve head radial runout.

If it measures more than the limit, replace the valve.

**Service Limit: 0.03 mm (0.001 in)**

09900-20606: Dial gauge (1/100 mm)

09900-20701: Magnetic stand

09900-21304: V-block (100 mm)

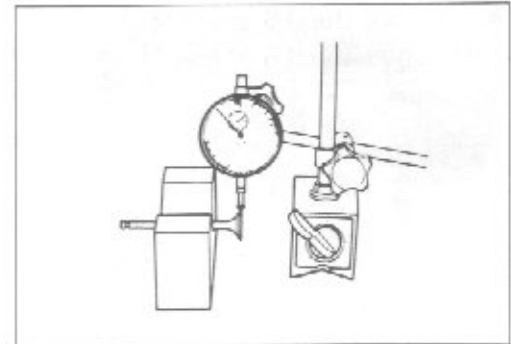

### VALVE FACE WEAR

Visually inspect each valve for wear of its seating face. Replace any valve with an abnormally worn face.

The thickness (T) decreases as the wear of the face advances. Measure the thickness and, if the thickness is found to have been reduced to the limit, replace it.

**Service Limit: 0.5 mm (0.02 in)**

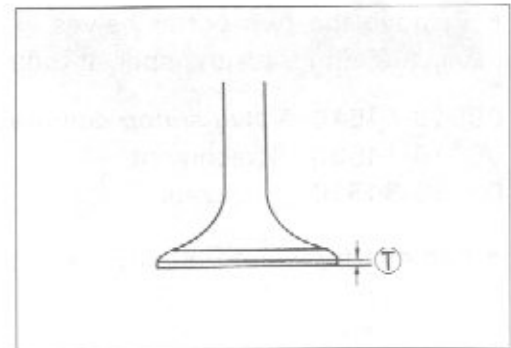

### VALVE GUIDE-VALVE STEM CLEARANCE

Measure the clearance in two directions, "X" and "Y", perpendicular to each other, by positioning the dial gauge as shown. If the clearance measured exceeds the limit, determine whether the valve or the guide should be replaced to reduce the clearance to the standard range:

**Service Limit: 0.35 mm (0.014 in)**

09900-20606: Dial gauge (1/100 mm)

09900-20701: Magnetic stand

09900-21304: V-block (100 mm)

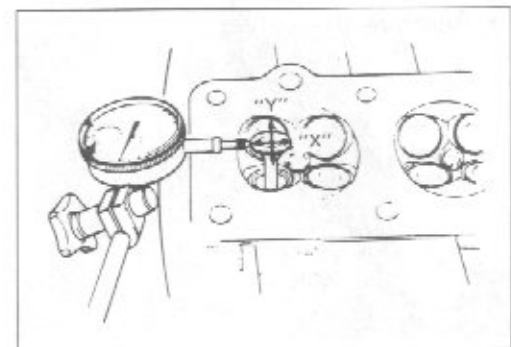

### VALVE STEM WEAR

If the valve stem is worn down to the limit to measure with a micrometer, where the clearance is found to be in excess of the limit indicated, replace the valve. If the stem is within the limit, replace the guide. After replacing valve or guide, be sure to recheck the clearance.

**Valve stem O.D. standard**

**IN. : 3.965–3.980 mm (0.1561–0.1567 in)**

**EX. : 3.950–3.965 mm (0.1555–0.1561 in)**

09900-20205: Micrometer

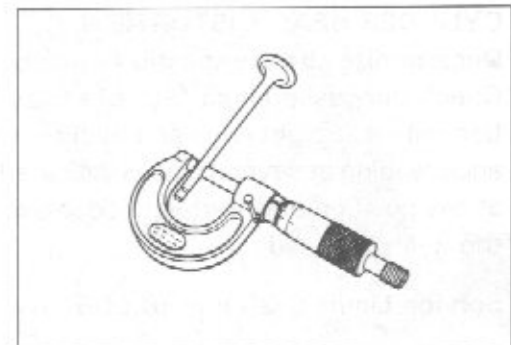

## VALVE GUIDE SERVICING

- Remove the valve guide with the special tool.

**09916-44310: Valve guide remover**

### NOTE:

- \* Discard the removed valve guide subassemblies.
- \* Only oversized valve guides are available as the replacement parts.

- Re-finish the valve guide holes in cylinder head with the reamer and handle.

**09916-00000: Valve guide reamer**

**09916-34541: Reamer handle**



- Oil the stem hole, too, of each valve guide and drive the guide into the guide hole with the special tools.

- ✦ **09916-44310: Valve guide remover/installer**
- 09916-53320: Valve guide installer attachment**

### CAUTION:

Failure to oil the valve guide hole before driving the new guide into place may result in a damaged guide or head.

- After fitting the valve guides, re-finish their guiding bores with the reamer.

**09916-34570: Valve guide reamer**

**09916-34541: Reamer handle**

### NOTE:

Be sure to clean and oil the guides after reaming.

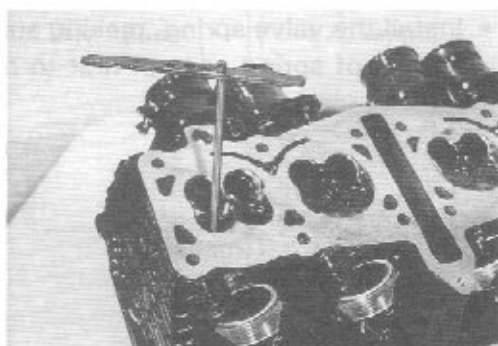
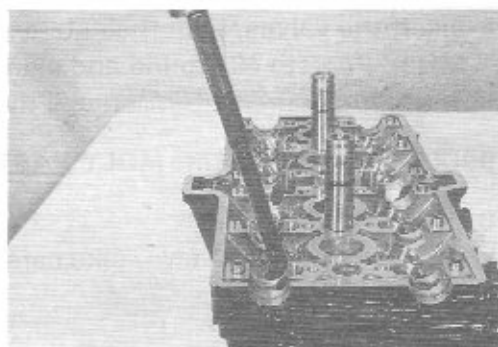
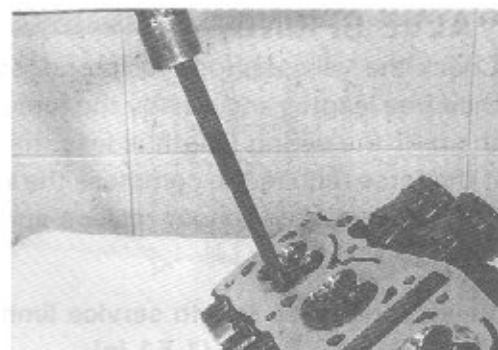

## VALVE SPRING

Check the valve springs for proper strength by measuring their free lengths and also by the force required to compress them. If the spring length is less than the service limit, or if the force required to compress the spring does not fall within the specified range, replace springs.

**Valve spring free length service limit**  
IN. & EX.: 38.3 mm (1.51 in)

**Valve spring tension standard**  
IN. & EX.: 11.7–14.3 kg/35.3 mm  
(25.8–31.5 lbs/1.39 in)

- Insert the valves, with their stems coated with (SUZUKI MOLY PASTE) all around and along the full stem length without any break. Similarly oil the lip of the stem seal.

**99000-25140: SUZUKI MOLY PASTE**

### CAUTION:

When inserting each valve, take care not to damage the lip of the stem seal.

- Install the valve spring, making sure that the close-pitch end ① of spring goes in first to rest on the head.

- Fit a valve spring retainer, compress the spring with a special tool and fit the cotter halves to the stem end.

**09916-14510: Valve spring compressor**

**09916-14530: Attachment**

**09916-84510: Tweezers**

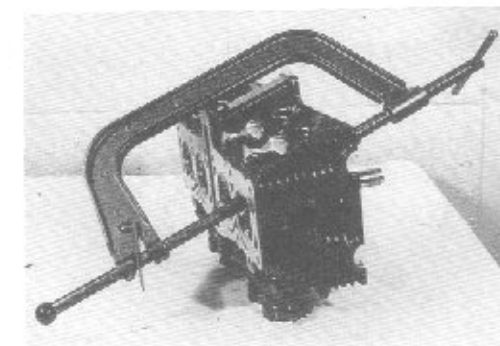
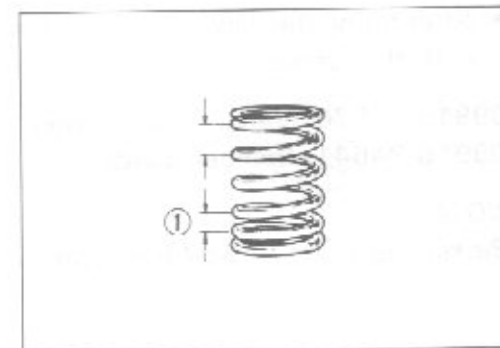
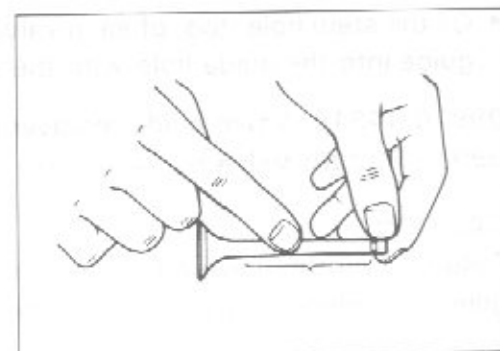
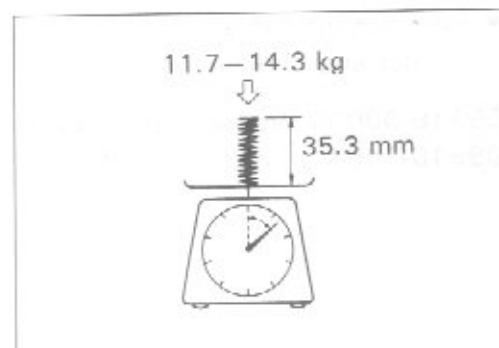
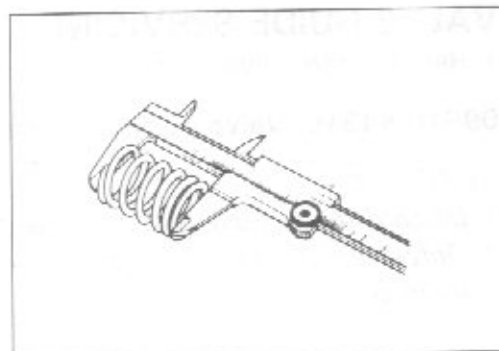

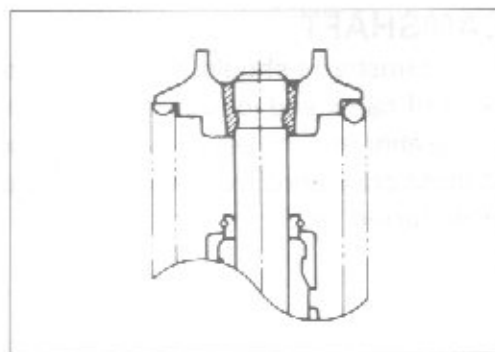

- Install the shims.

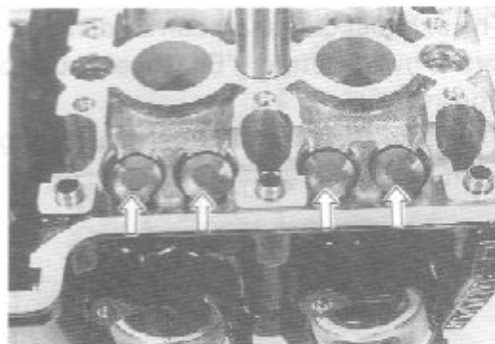

- Install the tappets to the correct position as shown in the illustration.

**CAUTION:**

Be careful not to confuse the intake tappet with exhaust tappet.

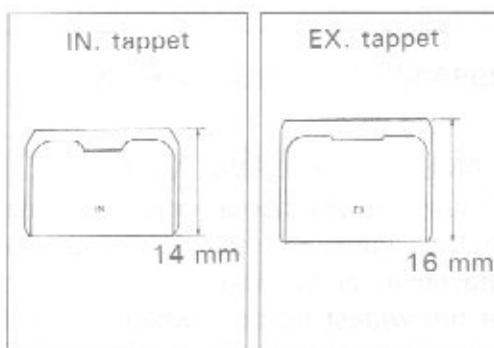
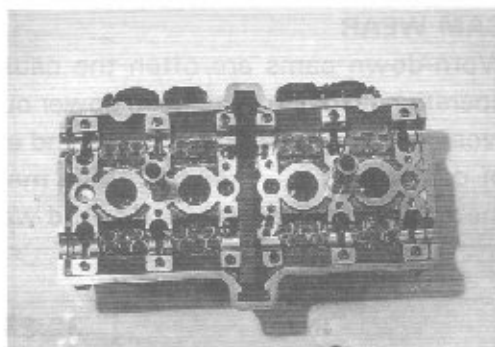

## CAMSHAFT

Both camshafts should be checked for runout and also for wear of cams and journals if the engine has been noted as giving abnormal noise or vibration or lack power output. Any of these conditions may be caused by camshafts worn down or distorted to the service limit.

The exhaust camshaft can be distinguished from that of the intake by the letters "E" (for exhaust) as against letters "D" (for intake).

Similarly, the right end can be distinguished by the notch from the left end.

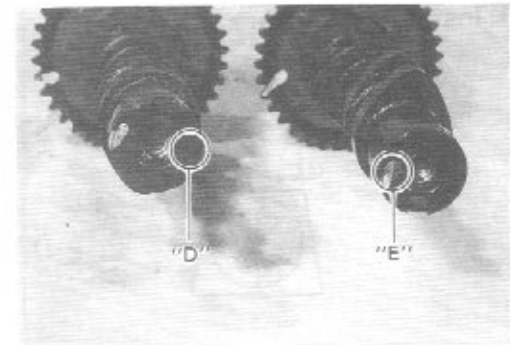
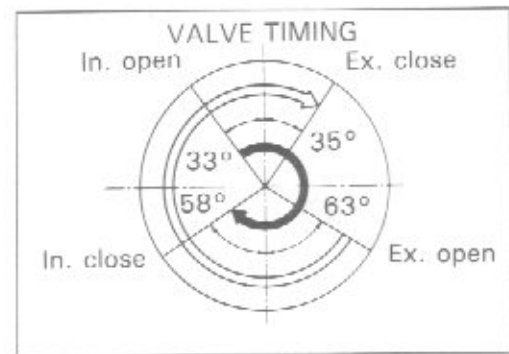

## CAM WEAR

Worn-down cams are often the cause of mistimed valve operation resulting in reduced power output. The limit of cam wear is specified for both intake and exhaust cams in terms of cam height (H), which is to be measured with a micrometer. Replace camshafts if found worn down to the limit.

Cam height (H)	Service Limit
IN.	32.330 mm (1.2728 in)
EX.	31.740 mm (1.2496 in)

09900-20202: Micrometer (25 – 50 mm)

## CAMSHAFT JOURNAL WEAR

Determine whether or not each journal is worn down to the limit by measuring the oil clearance with the camshaft installed in place. Use plastigauge to read the clearance at the widest portion, which is specified as follows:

**Camshaft journal oil clearance**

**Service Limit: 0.150 mm (0.0059 in)**

**NOTE:**

*Install the each holder to their original positions.*

- Tighten the camshaft holder bolts evenly and diagonally to the specified torque.

**Tightening torque: 8 – 12 N·m**  
(0.8 – 1.2 kg·m, 6.0 – 8.5 lb·ft)

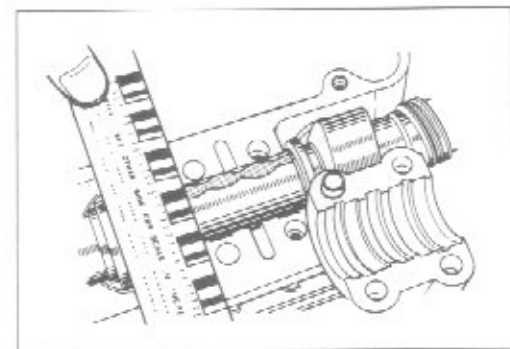
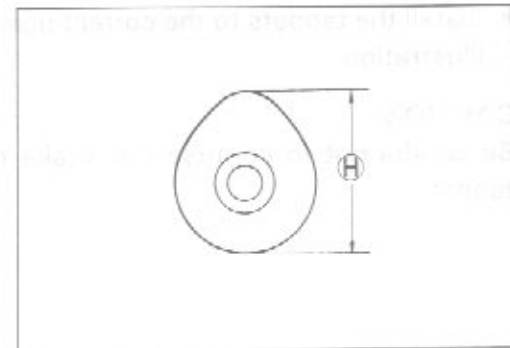

**NOTE:**

Do not rotate the camshaft with plastigauge is in place.

- Remove the camshaft holders, and read the width or compressed plastigauge with envelope scale. This measurement should be taken at the widest part.

If the camshaft journal oil clearance measured exceeds the limit, measure the following two portions:

- Inner diameter of camshaft journal holder

09900-20602: Dial gauge (1/1000 mm)

09900-22403: Small bore gauge (18–35 mm)

Camshaft journal holder I.D.	Standard
IN. & EX.	22.012–22.025 mm (0.8666–0.8671 in)

- Outer diameter of camshaft journal

09900-20205: Micrometer (0–25 mm)

Camshaft journal O.D.	Standard
IN. & EX.	21.959–21.980 mm (0.8645–0.8654 in)

Replace the camshaft or cylinder head depending upon which one exceeds the specification.

**CAMSHAFT RUNOUT**

Measure the runout with a dial gauge. Replace the camshaft if the runout exceeds the limit.

09900-20606: Dial gauge (1/1000 mm)

09900-20701: Magnetic stand

09900-21304: V-block (100 mm)

Camshaft runout	Service Limit
IN. & EX.	0.1 mm (0.004 in)

**CAM SPROCKET**

The fixed position of each cam sprocket on each camshaft is determined by arrow mark "3", on INTAKE sprocket, or arrow marks "1" and "2", on EXHAUST sprocket, located in reference to the notch ① in the right end of each camshaft.

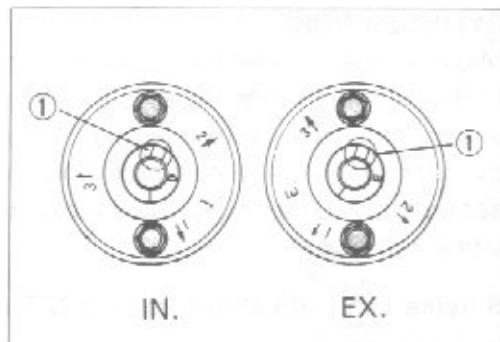
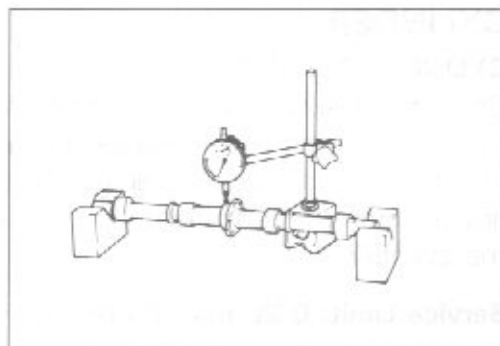
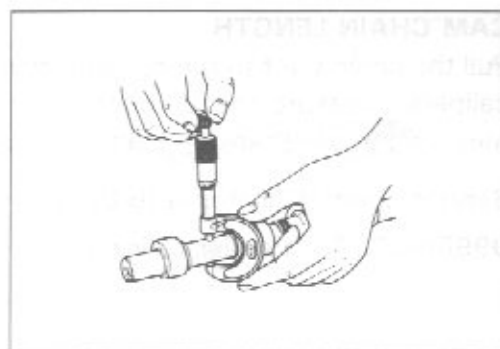
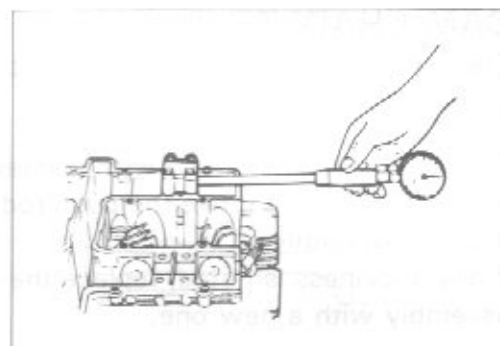

**REASSEMBLY**

- Apply **THREAD LOCK SUPER "1303"** to the threads of cam sprocket bolts, and tighten them to the specified torque.

**99000-32030: THREAD LOCK SUPER "1303"**

Cam sprocket bolt: 24–26 N·m  
(2.4–2.6 kg-m, 17.5–19.0 lb-ft)

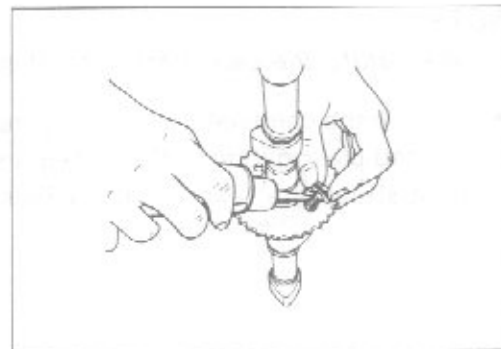
**CAM CHAIN TENSIONER**

The cam chain is maintained at the proper tension by an automatically adjusted tensioner.

Turn the cylinder shaft ① with a screwdriver in the clockwise direction and move the push rod ② in place to see if it slides smoothly.

If any stickiness is noted, replace the cam chain tensioner assembly with a new one.

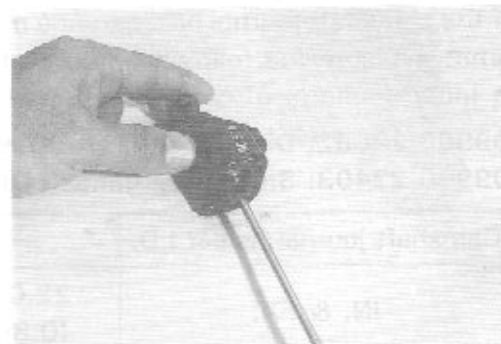
**CAM CHAIN LENGTH**

Pull the chain tight to remove any slack, then using vernier calipers, measure the 20-pitch length of cam chain. If it measures more than the limit, replace the cam chain.

**Service Limit: 128.9 mm (5.07 in)**

**09900-20102: Vernier calipers**

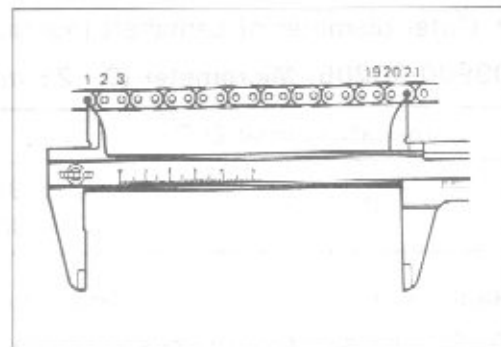
**CYLINDER****CYLINDER DISTORTION**

Check the gasketed surface of the cylinder for distortion with a straightedge and thickness gauge, taking a clearance reading at several places as indicated. If the largest reading at any position of the straightedge exceeds the limit, replace the cylinder.

**Service Limit: 0.20 mm (0.008 in)**

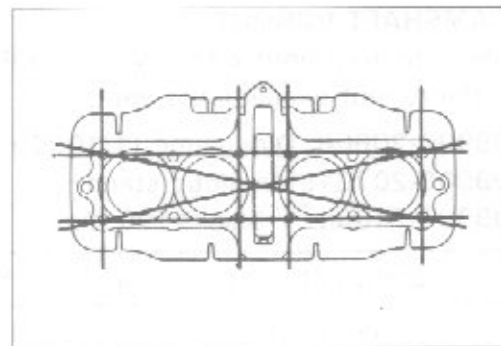
**CYLINDER BORE**

Measure the cylinder bore diameter at six places. If any one of the measurements exceeds the limit, overhaul the cylinder and replace the piston with an oversize, or replace the cylinder. Once the remaining cylinders must be also rebored accordingly. Otherwise, the imbalance might cause excess vibration.

**Service Limit: 49.090 mm (1.9327 in)**

**09900-20508: Cylinder gauge set**

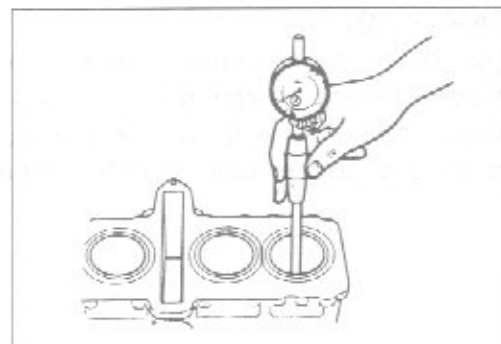

## PISTON

### PISTON DIAMETER

Using a micrometer, measure the piston outside diameter at the place as shown in Fig. If the measurement is less than the limit, replace the piston with a new one.

**Service Limit: 48.880 mm (1.9244 in)**

**99000-20202: Micrometer**

**Piston oversize: 0.5, 1.0 mm**

### PISTON-CYLINDER CLEARANCE

As a result of the above measurement, if the clearance between the piston and cylinder exceeds the following service limit, treat either to replace with an oversize piston overhauling the cylinder or replacing both cylinder and piston.

**Service Limit: 0.120 mm (0.0047 in)**

### PISTON RING-GROOVE CLEARANCE

Using a thickness gauge, measure the side clearances of the 1st and 2nd rings. If any of the clearances exceeds the limit, replace both piston and piston rings.

**Service Limit:**

**1st : 0.180 mm (0.0071 in)**

**2nd: 0.150 mm (0.0059 in)**

**09900-20803: Thickness gauge**

Piston ring groove width	Standard
1st & 2nd	0.81–0.83 mm (0.032–0.033 in)
Oil	2.01–2.03 mm (0.079–0.080 in)

Piston ring thickness	Standard
1st & 2nd	0.77–0.79 mm (0.030–0.031 in)

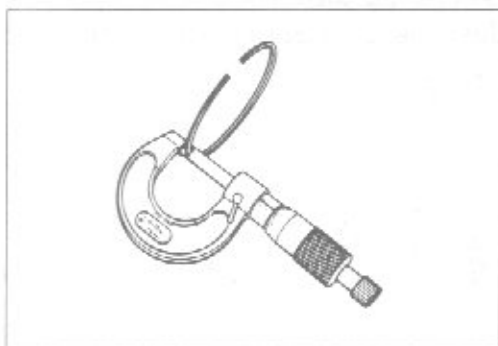
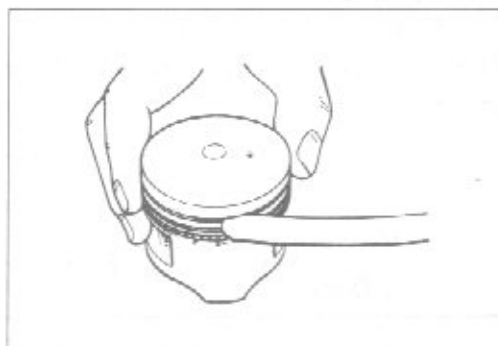
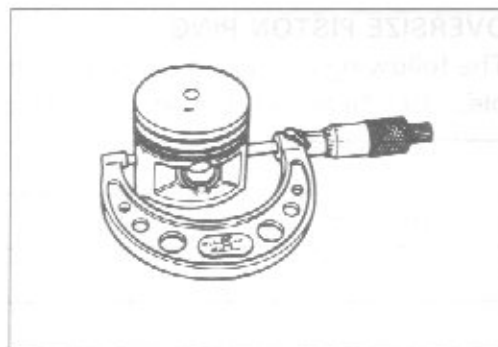
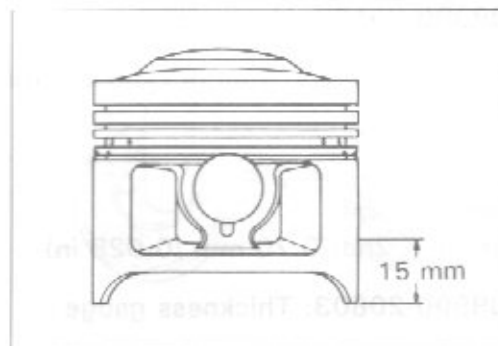
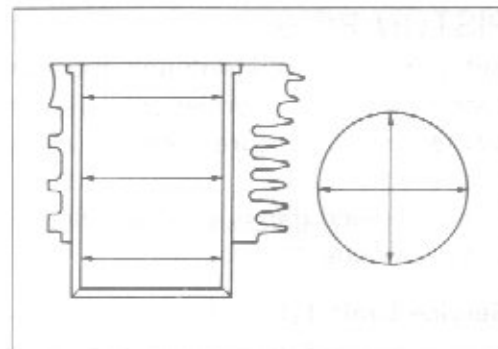



## PISTON RING

Before installing piston rings, measure the free end gap of each ring using a vernier calipers. Next, fit the ring in the cylinder, and measure each ring end gap using a thickness gauge.

If the free end gap is smaller than service limit, replace it with new one.

**Service Limit 1st : 5.6 mm (0.22 in)**

**2nd: 4.2 mm (0.17 in)**

**09900-20102: Vernier calipers**

If the end gap is larger than service limit, replace it with new one.

**Piston ring end gap**

**Service Limit**

**1st and 2nd: 0.70 mm (0.028 in)**

**09900-20803: Thickness gauge**

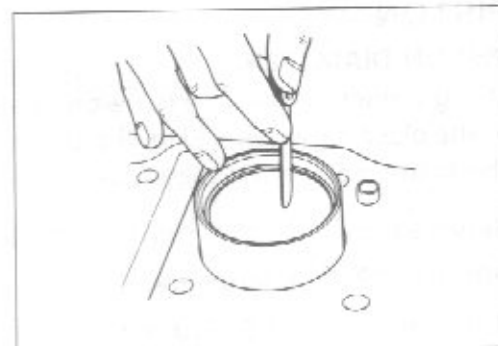

## OVERSIZE PISTON RING

The following two types of oversize piston rings are available. They bear the following identification numbers.

	1st	2nd
0.5 mm	50	50
1.0 mm	100	100

## OVERSIZE OIL RING

The following two types of oversize oil ring are available. They bear the following identification marks.

SIZE	COLOR
STD	Painted blue
0.5 mm O.S.	Painted red
1.0 mm O.S.	Painted yellow

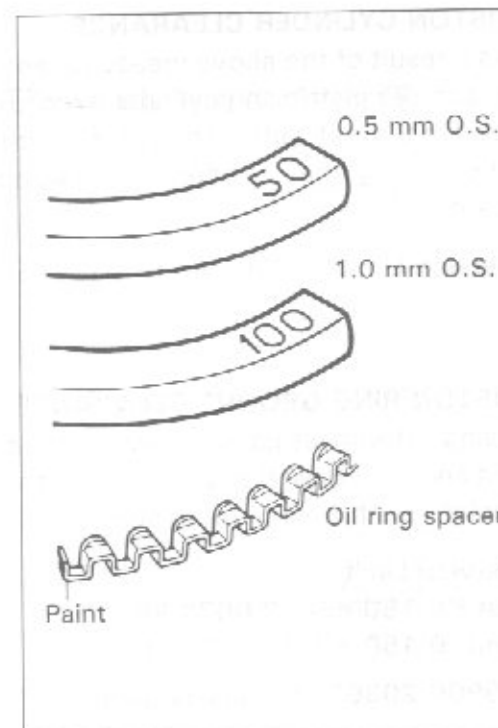

## OVERSIZE SIDE RAIL

Just measure out side diameter to identify the size.

## PISTON PIN

Using a small bore gauge, measure the piston pin bore inside diameter, and using a micrometer, measure the piston pin outside diameter. If the difference between these two measurements is more than the limits, replace both piston and piston pin.

### PISTON PIN BORE

**Service Limit:** 14.030 mm (0.5524 in)

**09900-20602:** Dial gauge (1/1000 mm)

**09900-22401:** Small bore gauge (10–18 mm)

### PISTON PIN DIAMETER

Using a micrometer, measure the piston pin outside diameter at three positions.

**Service Limit:** 13.980 mm (0.5504 in)

**09900-20205:** Micrometer (0–25 mm)

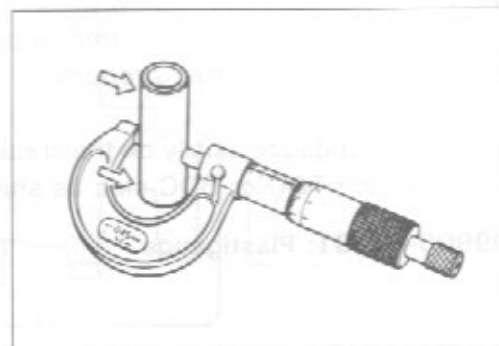
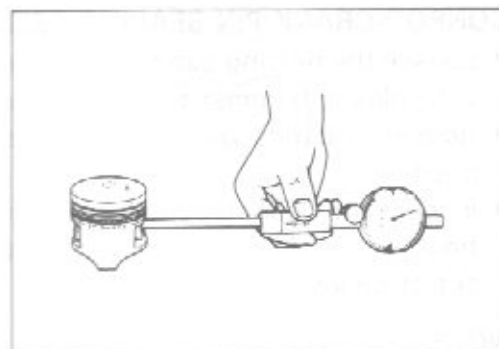

## CONROD

### CONROD SMALL END I.D.

Using a small bore gauge, measure the conrod small end inside diameter.

**Service Limit:** 14.040 mm (0.5528 in)

**09900-20602:** Diam gauge (1/1000 mm)

**09900-22401:** Small bore gauge (10–18 mm)

If the conrod small end inside diameter exceeds the above mentioned limit, replace the conrod.

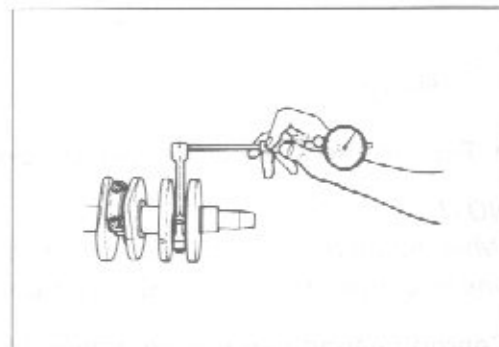

### CONROD BIG END SIDE CLEARANCE

Check the conrod side clearance using a thickness gauge.

**Service Limit:** 0.3 mm (0.012 in)

**09900-20803:** Thickness gauge

If the side clearance exceeds the limit, replace either conrod or crankshaft to measure both widths.

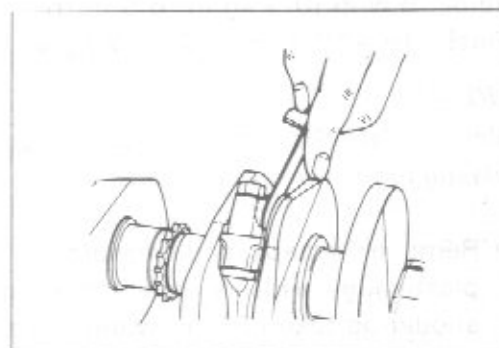

**09900-20205:** Micrometer (0–25 mm)

**09900-20605:** Dial calipers (10–34 mm)

	Standard
Conrod big end width	15.95–16.00 mm (0.628–0.630 in)
Crank pin width	16.10–16.15 mm (0.634–0.636 in)

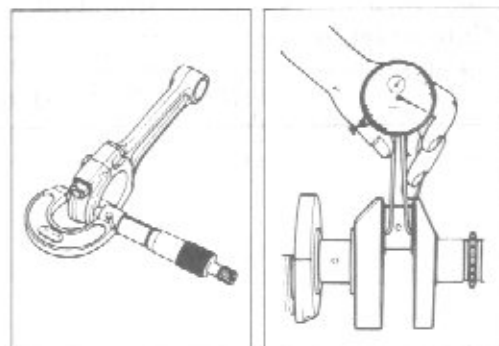

**CONROD-CRANK PIN BEARING SELECTION**

- Loosen the bearing cap nuts, and tap the bolt end lightly with plastic hammer to remove bearing cap.
- Remove the rods, and mark them to identify the cylinder position.
- Inspect the bearing surfaces for any sign of fusion, pitting, burn, or flaws. If any, replace them with a specified set of bearings.

**NOTE:**

Never try to remove or loosen the conrod cap bolts due to their possible loosening in the rod. Once displaced, the bearing cap will not be fitted properly.

- Place plastigauge axially on the crank pin avoiding oil hole and at the TDC or BDC side as shown.

**09900-22301: Plastigauge**

- Tighten the bearing cap with two-step torque values.

**NOTE:**

When fitting bearing cap to crank pin, be sure to discriminate one end from the other, namely front and rear.

**Conrod bearing cap nut tightening torque**

Initial: 9 N·m (0.9 kg-m, 6.5 lb-ft)

Final : 16–17 N·m (1.6–1.7 kg-m, 11.5–12.5 lb-ft)

**NOTE:**

Never rotate the crankshaft or conrod when a piece of the plastigauge is in the clearance.

- Remove the caps, and measure the width of compressed plastigauge with its envelope scale. This measurement should be taken at the widest part.

Conrod big end oil clearance	Standard	Service Limit
	0.024–0.048 mm (0.0009–0.0019 in)	0.080 mm (0.0031 in)

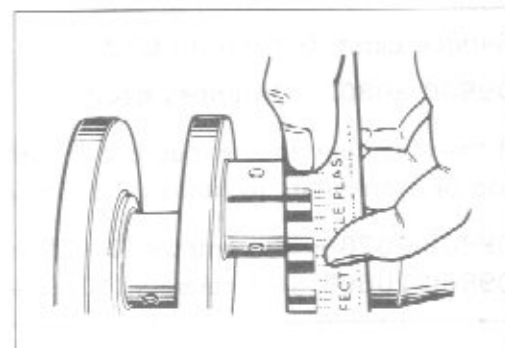
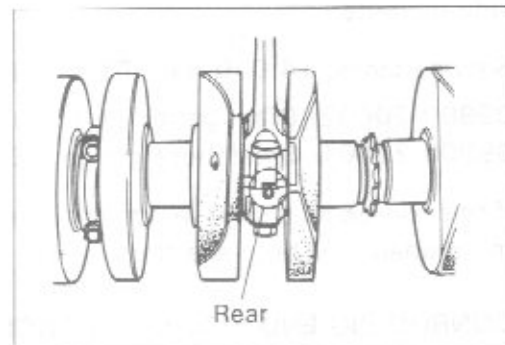
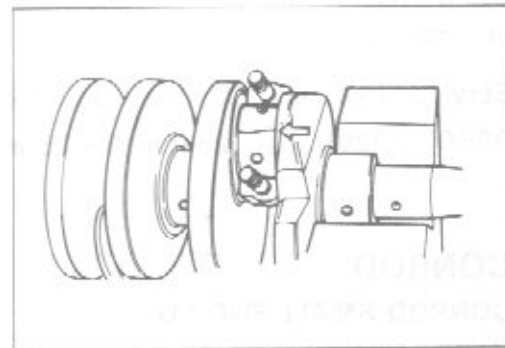
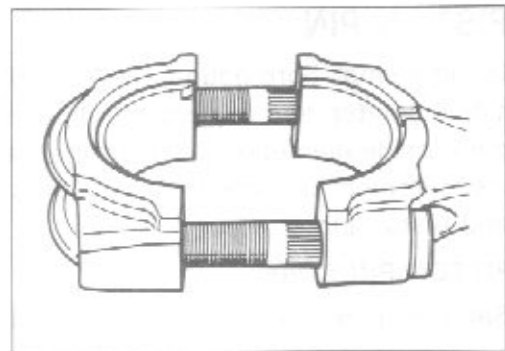

If oil clearance exceeds the service limit, select the specific bearing to refer below table.

The bearing distinguished by color painted is selected easily by the following two steps.

- Check the corresponding conrod I.D. code number ①, "1" or "2".
- Check the corresponding crank pin O.D. code number ②, "1", "2" or "3".

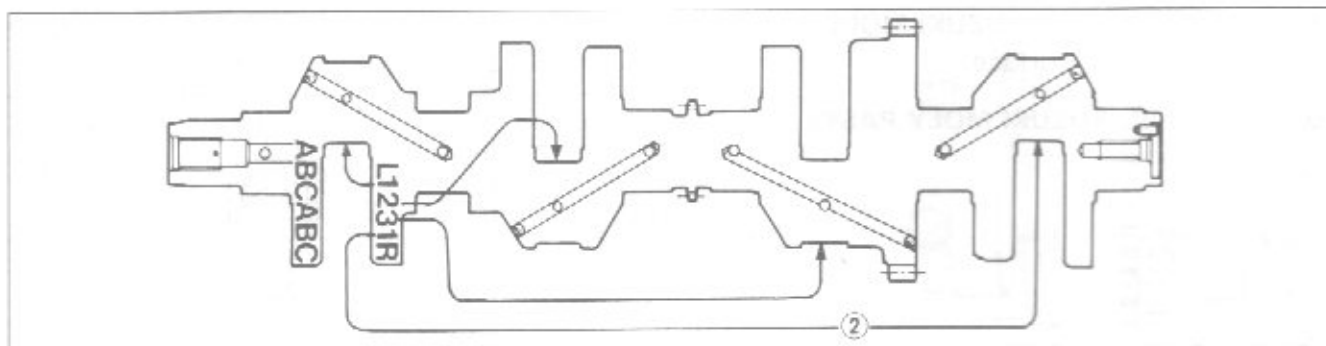
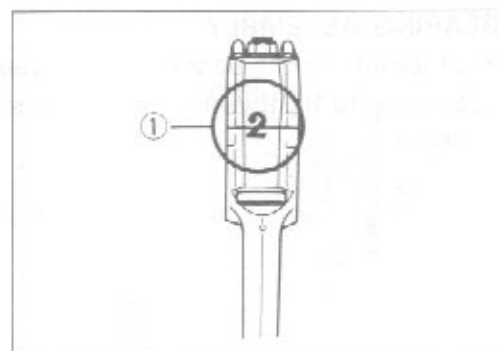

Bearing selection table

		Crank pin O.D. ②		
		Code	1	2
Conrod I.D. ①	1	Green	Black	Brown
	2	Black	Brown	Yellow

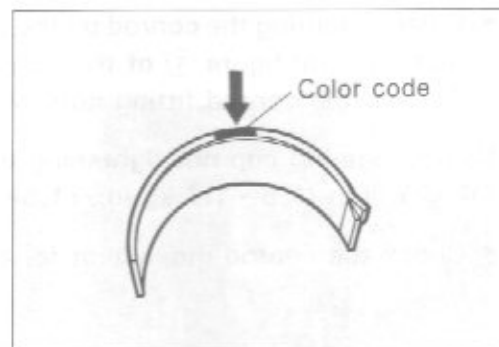
**CAUTION:**

Bearing should be replaced as a set.

**(REFERENCE DATA)****Conrod I.D. specification**

Code	I.D. specification
1	30.000–30.008 mm (1.1811–1.1814 in)
2	30.008–30.016 mm (1.1814–1.1817 in)

**Crank pin O.D. specification**

Code	O.D. specification
1	26.992–27.000 mm (1.0627–1.0630 in)
2	26.984–26.992 mm (1.0624–1.0627 in)
3	26.976–26.984 mm (1.0620–1.0624 in)

**Bearing thickness**

Color (Part No.)	Thickness
Green (12164-05C00-0A0)	1.484–1.488 mm (0.0584–0.0586 in)
Black (12164-05C00-0B0)	1.488–1.492 mm (0.0586–0.0587 in)
Brown (12164-05C00-0C0)	1.492–1.496 mm (0.0587–0.0589 in)
Yellow (12164-05C00-0D0)	1.496–1.500 mm (0.0589–0.0591 in)

**BEARING ASSEMBLY**

- When fitting the bearings to the bearing cap and conrod, be sure to fix the stopper part first, and press the other end.

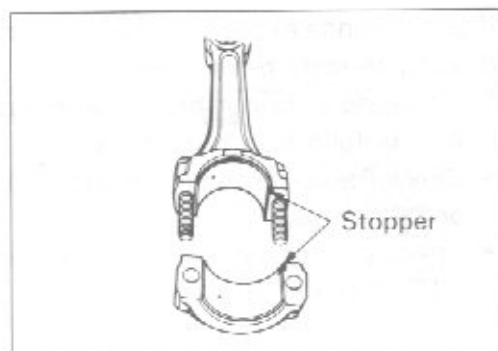

- Apply engine oil or SUZUKI MOLY PASTE to the crank pin and bearing surface.

**99000-25140: SUZUKI MOLY PASTE**

- When mounting the conrod on the crankshaft, make sure that numeral figure ① of the conrod faces rearward.
- Tighten the conrod fitting nuts with specified torque.

**Conrod bearing cup nut tightening torque**

16–17 N·m (1.6–1.7 kg·m, 11.5–12.5 lb-ft)

- Check the conrod movement for smooth turning.

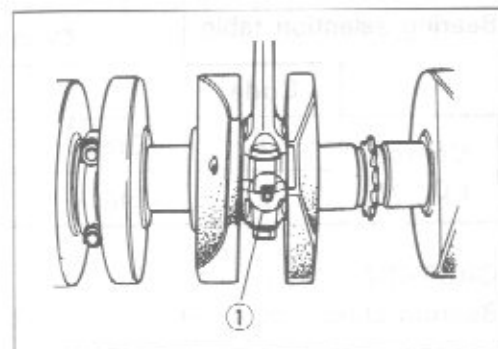
**CRANKSHAFT****CRANKCASE-CRANKSHAFT BEARING SELECTION**

- Inspect each bearing of upper and lower crank cases for any damage.

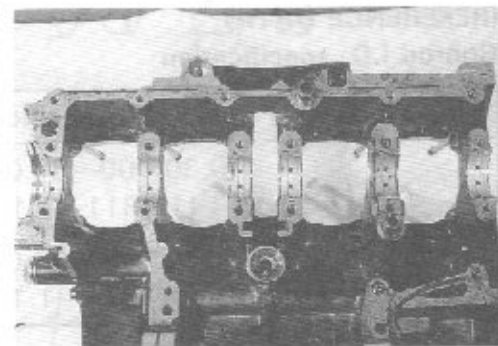

- Place the plastigauge on each crankshaft journal in the usual manner.

**NOTE:**

*Do not place the plastigauge on the oil hole, and do not rotate the shaft when plastigauge is in place.*

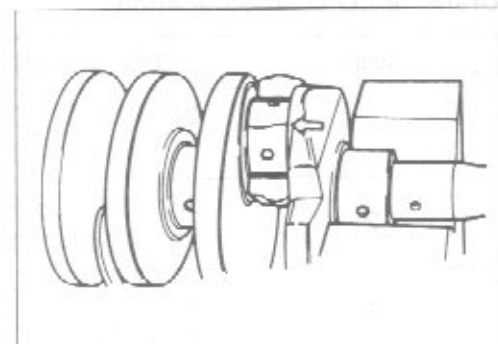
**09900-22301: Plastigauge**

- Mate the lower crankcase with the upper crankcase, and tighten the crankshaft tightening bolts with specified torque value as the indicated order.

#### 6 mm crankshaft tightening bolt

Initial: 6 N·m (0.6 kg-m, 4.5 lb-ft)

Final : 8–12 N·m (0.8–1.2 kg-m, 6.0–8.5 lb-ft)

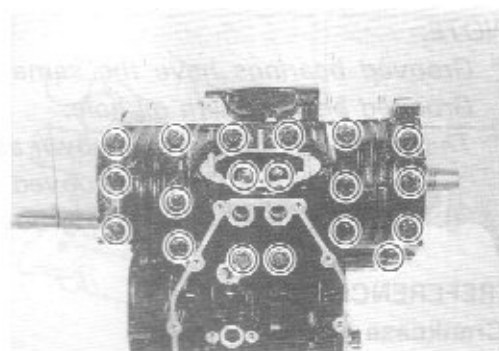

- Remove the lower crankcase, and measure the width of compressed plastigauge in the usual manner.

Crankshaft journal oil clearance	Standard	Service Limit
	0.020–0.044 mm (0.0008–0.0017 in)	0.080 mm (0.0031 in)

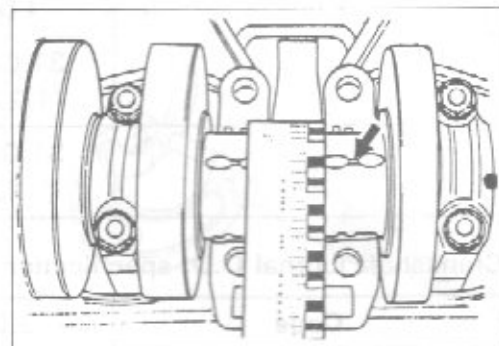

If the width at the widest part exceeds the limit, replace the set of bearings with new ones to refer the selection table.

- Check the corresponding crankcase journal I.D. code number ① "A" or "B" which are stamped on the rear surface of upper crankcase.
- Check the corresponding crankshaft journal O.D. code number ② "A", "B" or "C".

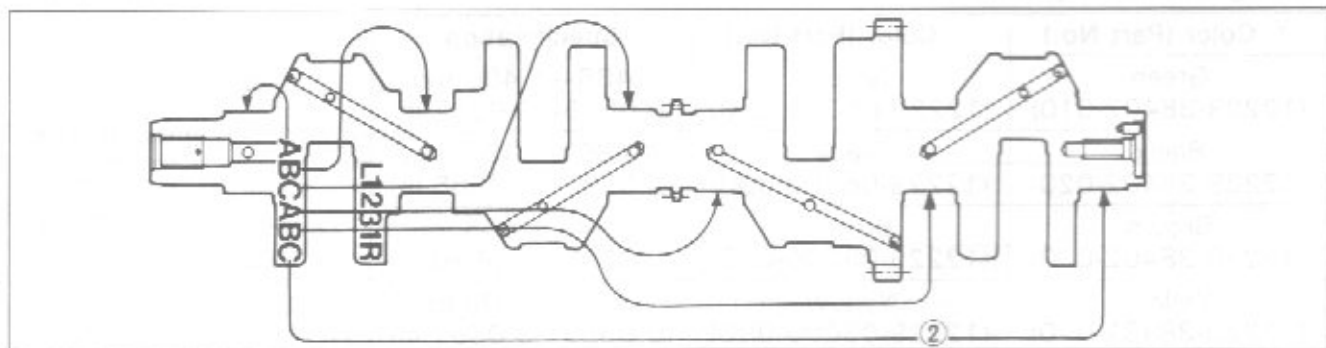

Bearing selection table		Crankshaft journal O.D. ②		
		Code	A	B
Crankcase I.D. ①	A	Green	Black	Brown
	B	Black	Brown	Yellow

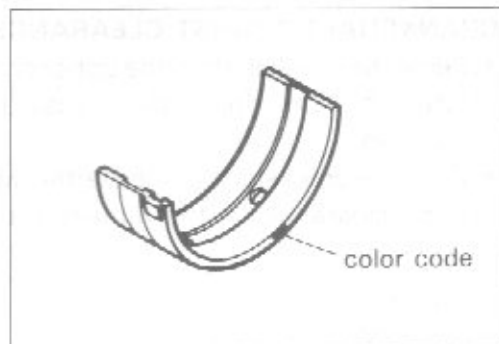

**NOTE:**

\* Grooved bearings have the same specification as the Grooved bearing with oil hole.

\* These parts numbers are shown as follows.

①: 12229-38402-XXX. (Grooved bearing)

②: 12229-05C00-XXX. (No grooved bearing)

**(REFERENCE DATA)****Crankcase I.D. specification**

Code	I.D. specification
A	31.000–31.008 mm (1.2205–1.2208 in)
B	31.008–31.016 mm (1.2208–1.2211 in)

**Crankshaft journal O.D. specification**

Code	O.D. specification
A	27.992–28.000 mm (1.1020–1.1024 in)
B	27.984–27.992 mm (1.1017–1.1020 in)
C	27.976–27.984 mm (1.1014–1.1017 in)

**Bearing thickness specification**

① Color (Part No.)	② Color (Part No.)	Specification
Green (12229-38402-010)	Green (12229-05C00-0A0)	1.486–1.490 mm (0.0585–0.0587 in)
Black (12229-38402-020)	Black (12229-05C00-0B0)	1.490–1.494 mm (0.0587–0.0588 in)
Brown (12229-38402-030)	Brown (12229-05C00-0C0)	1.494–1.498 mm (0.0588–0.0590 in)
Yellow (12229-38402-040)	Yellow (12229-05C00-0D0)	1.498–1.502 mm (0.0590–0.0591 in)

**CRANKSHAFT THRUST CLEARANCE**

- Place the crankshaft in the upper crankcase and insert the left-side and right-side thrust bearings on regular position.
- Push the crankshaft to the starter clutch side, so that there is no clearance on the right-side thrust bearing.

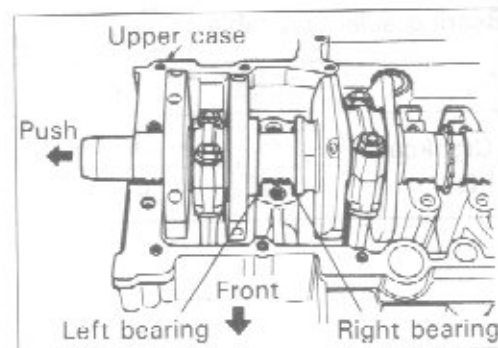
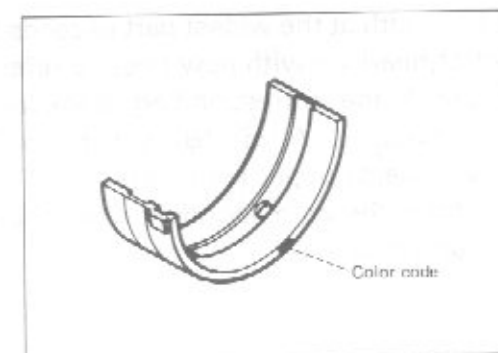
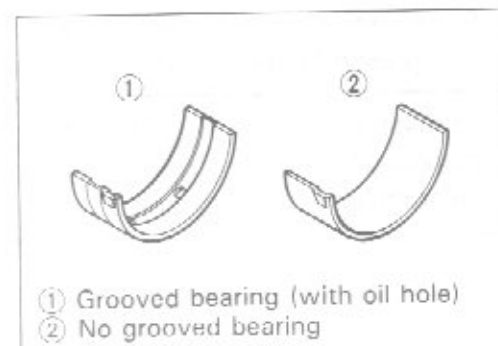
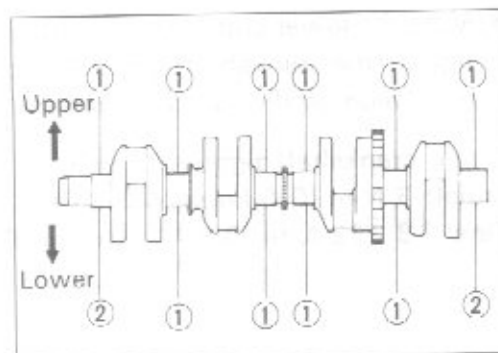

- Measure the thrust clearance on the left-side with a thickness gauge.

**Standard: 0.045–0.100 mm (0.0018–0.0039 in)**

**09900-20803: Thickness gauge**

If the thrust clearance exceeds the standard range, adjust the thrust clearance to replace the thrust bearing as the following manner:

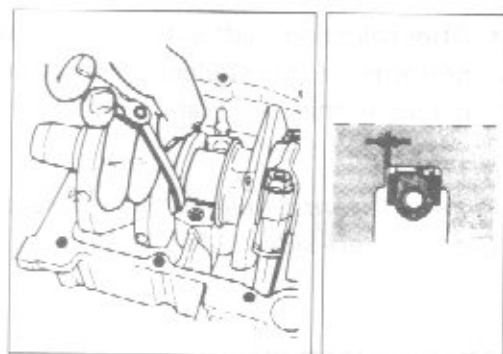

- Remove the right-side thrust bearing and measure its thickness with a micrometer.

**09900-20205: Micrometer (0–25 mm)**

- If the thickness of the right-side thrust bearing is below standard, replace with a new bearing painted GREEN.
- Once again perform the thrust clearance measurement mentioned on above.

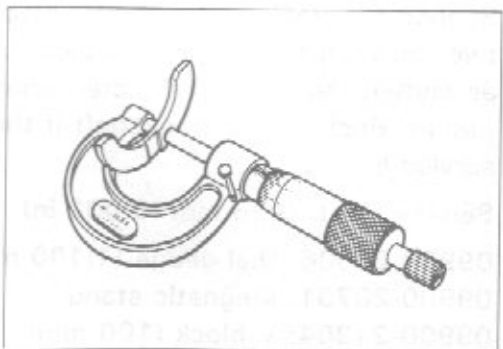

Right-side thrust bearing thickness	Standard
	2.425–2.450 mm (0.0955–0.0965 in)

- If the right-side thrust bearing is within the standard range, reinsert the right-side thrust bearing and remove the left-side thrust bearing.
- As shown in the illustration, measure the clearance with a thickness gauge before inserting the left side thrust bearing.

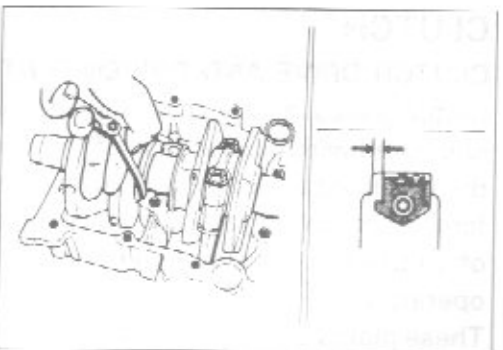

**09900-20803: Thickness gauge**

- Select the left-side thrust bearing to refer the following thrust bearing selection table.

**Thrust bearing selection table**

Clearance before inserting thrust bearing	Color (Part No.)	Thrust bearing thickness	Thrust clearance
2.420–2.445 mm (0.0953–0.0963 in)	Red (12228-38411)	2.350–2.375 mm (0.0925-0.0935 in)	0.045–0.095 mm (0.0018–0.0037 in)
2.445–2.470 mm (0.0963–0.0972 in)	Black (12228-38412)	2.375–2.400 mm (0.0935–0.0945 in)	
2.470–2.495 mm (0.0972–0.0982 in)	Blue (12228-38413)	2.400–2.425 mm (0.0945–0.0955 in)	
2.495–2.520 mm (0.0982–0.0992 in)	Green (12228-38414)	2.425–2.450 mm (0.0955–0.0965 in)	
2.520–2.545 mm (0.0992–0.1002 in)	Yellow (12228-38415)	2.450–2.475 mm (0.0965–0.0974 in)	
2.545–2.575 mm (0.1002–0.1014 in)	White (12228-38416)	2.475–2.500 mm (0.0974-0.0984 in)	



- After selecting a left-side thrust bearing, insert it and again perform the thrust clearance measurement to make sure it falls within the standard range.

**NOTE:**

*Right-side thrust bearing has the same specification as the Green of left-side thrust bearing.*

**CRANKSHAFT RUNOUT**

Support the crankshaft with "V" blocks as shown, with the two end journals resting on the blocks. Set up the dial gauge, as shown, and rotate the crankshaft slowly to read the runout. Replace the crankshaft if the runout exceeds the service limit.

**Service Limit: 0.05 mm (0.002 in)**

**09900-20606: Dial gauge (1/100 mm)**

**09900-20701: Magnetic stand**

**09900-21304: V-block (100 mm)**

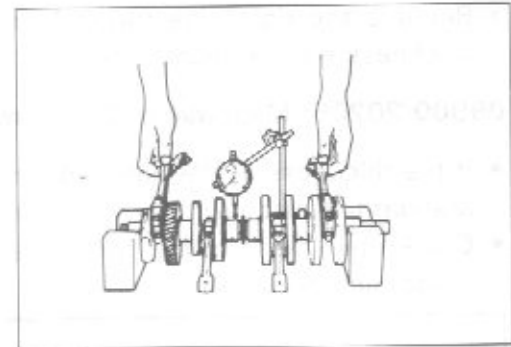
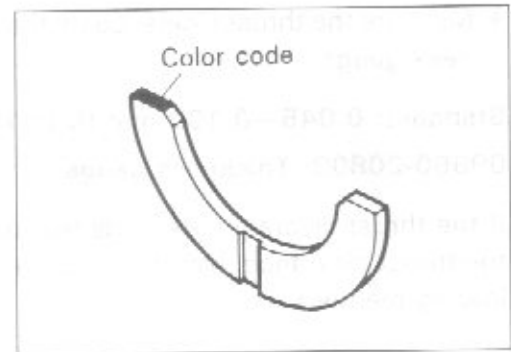
**CLUTCH****CLUTCH DRIVE AND DRIVEN PLATES**

Clutch plates in service remain in oily condition as they are lubricated with oil. Because of this condition, both drive and driven plates are subject to little wearing action and therefore last much longer. Their life depends largely on the quality of oil used in the clutch and also on the way the clutch is operated.

These plates are expendable: they are meant to be replaced when found worn down or distorted to the respective limit: use a vernier calipers to check thickness and a thickness gauge and surface plate to check distortion.

	Standard	Service Limit
Thickness	2.9–3.1 mm (0.11–0.12 in)	2.6 mm (0.10 in)
Claw width	11.8–12.0 mm (0.46–0.47 in)	11.2 mm (0.44 in)

**09900-20101: Vernier calipers**

Measure each driven plate for distortion with a thickness gauge.

Replace driven plates which exceed the limit.

**Service Limit: 0.10 mm (0.004 in)**

**09900-20803: Thickness gauge**

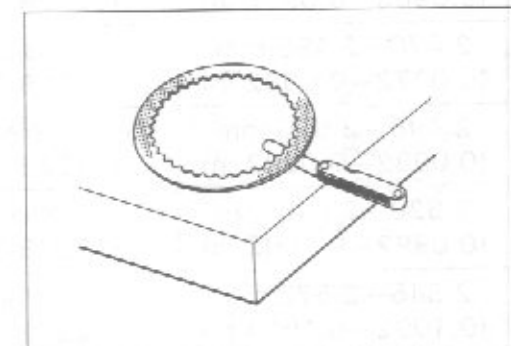
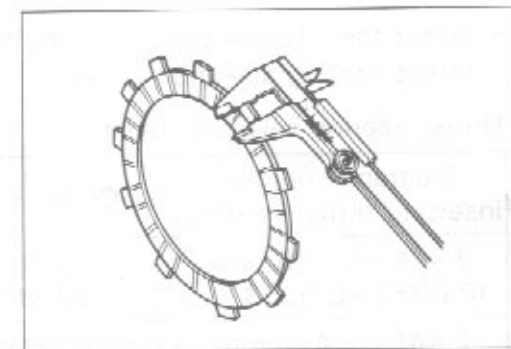
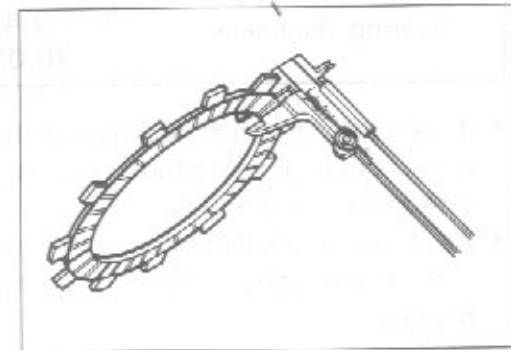

**CLUTCH SPRING FREE LENGTH**

Measure the free length of each coil spring with vernier calipers, and compare the elastic strength of each with the specified limit. Replace all the springs if any one of springs is not within the limit.

**Service Limit: 36.3 mm (1.43 in)**

**09900-20101: Vernier calipers**

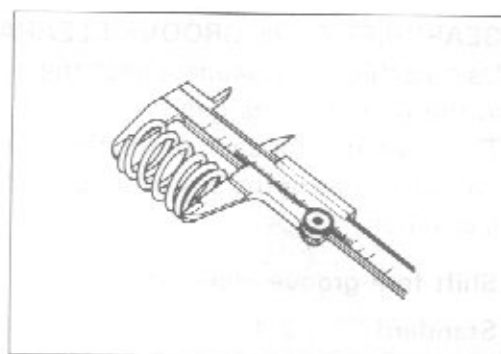
**OIL PUMP****CAUTION:**

Do not attempt to disassemble the oil pump assembly.  
The oil pump is available only as an assembly.

**TRANSMISSION****DISASSEMBLY**

- Disassemble the transmission gears as shown in the illustration.

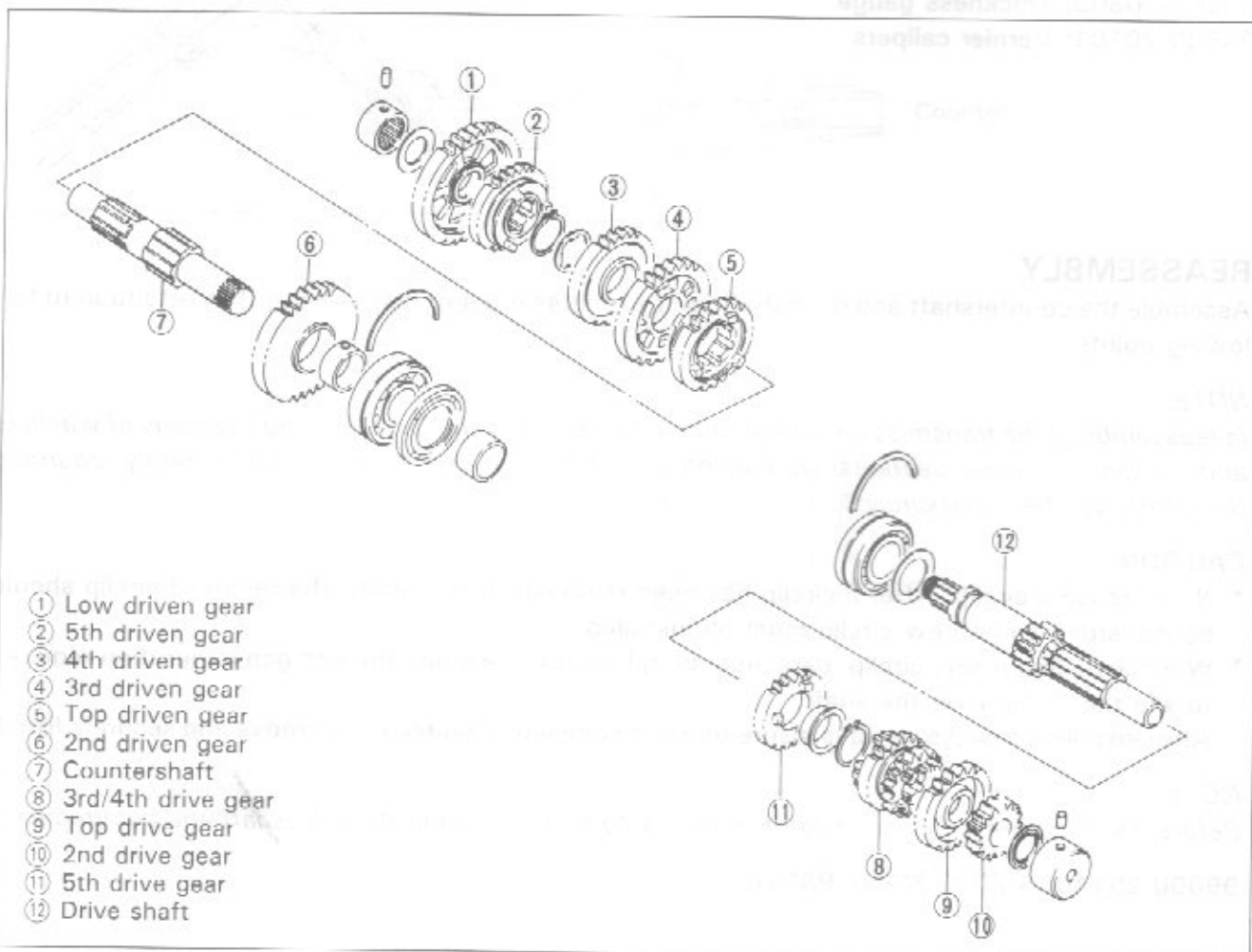

**GEARSHIFT FORK-GROOVE CLEARANCE**

Using a thickness gauge, check the gearshift fork clearance in the groove of its gear.

The clearance for each of the three gearshift forks plays an important role in the smoothness and positiveness of shifting action.

**Shift fork-groove clearance**

**Standard** : 0.1–0.3 mm (0.004–0.012 in)

**Service Limit**: 0.5 mm (0.02 in)

If the clearance checked is noted to exceed the standard range mentioned on above, check the following points:

**Shift fork groove width**

**Standard**: 5.0–5.1 mm (0.197–0.201 in)

**Shift fork thickness**

**Standard**: 4.8–4.9 mm (0.189–0.193 in)

If the shift fork groove width or shift fork thickness exceeds the standard, replace the fork or its gear, or both.

09900-20803: Thickness gauge

09900-20101: Vernier calipers

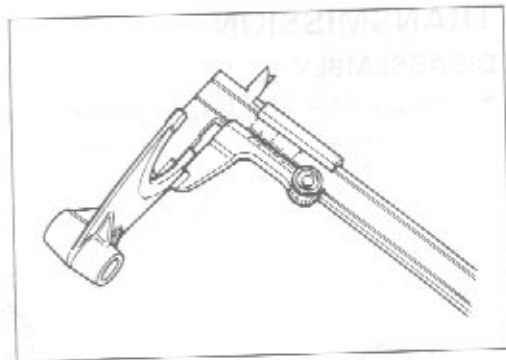
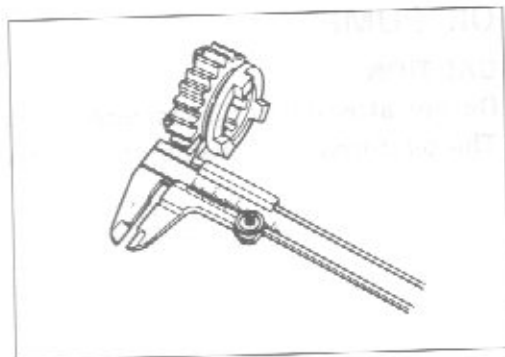
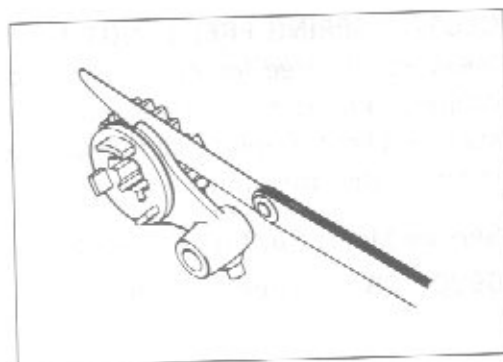
**REASSEMBLY**

Assemble the countershaft and driveshaft, in the reverse order of disassembly. Pay attention to following points:

**NOTE:**

*In reassembling the transmission, attention must be given to the locations and positions of washers and circlips. The cross sectional view given here will serve as a reference for correctly mounting the gears, washers and circlips.*

**CAUTION:**

- \* Never reuse a circlip. After a circlip has been removed from a shaft, the removed circlip should be discarded and a new circlip must be installed.
- \* When installing a new circlip, care must be taken not to expand the end gap larger than required to slip the circlip over the shaft.
- \* After installing a circlip, always insure that it is completely seated in its groove and securely fitted.

**NOTE:**

*Before installing the gears, coat lightly moly paste or engine oil to the driveshaft and countershaft.*

99000-25140: SUZUKI MOLY PASTE

- When installing a new circlip, pay attention to the direction of the circlip. Fit it to the side where the thrust is as shown in figure.

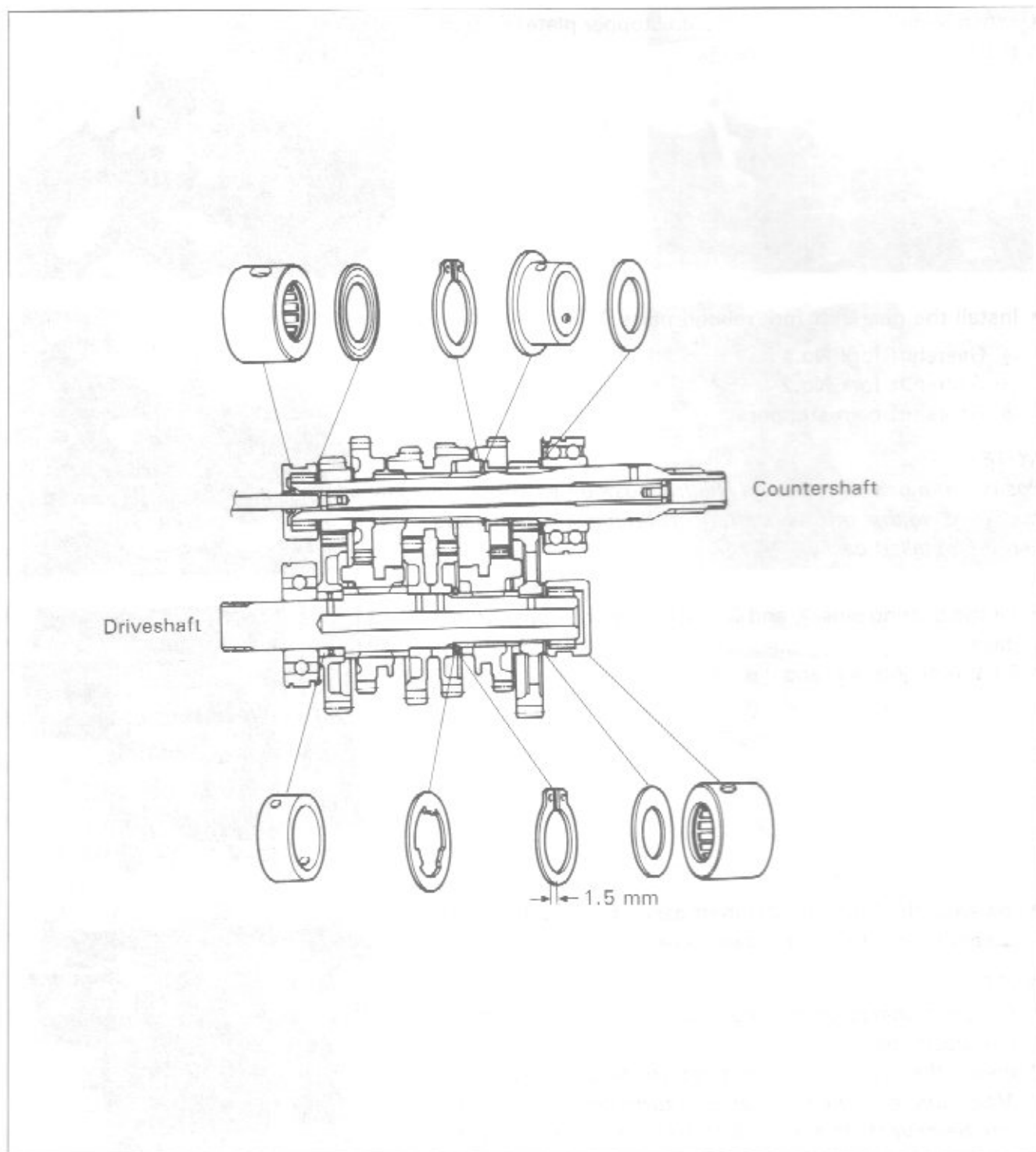
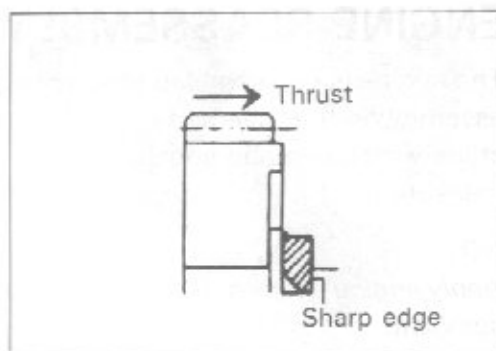

## ENGINE REASSEMBLY

The engine is reassembled by carrying out the steps of disassembly in the reversed order, but there are a number of steps which demand special descriptions or precautionary measures.

### NOTE:

Apply engine oil to each running and sliding part before reassembling.

- When installing the gearshift cam stopper plate (1), align the pin (2) with pin groove (3).

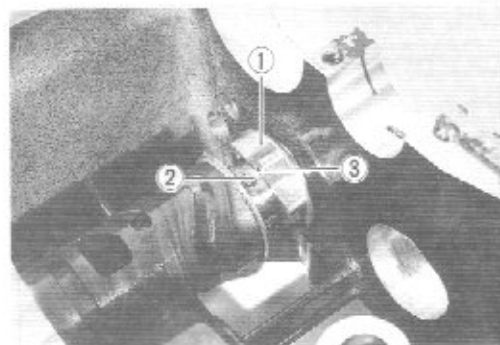

- Install the gearshift fork related parts.

- ④ Gearshift fork No.1
- ⑤ Gearshift fork No.2
- ⑥ Gearshift cam stopper

### NOTE:

Position the gearshift cam in Neutral position as shown in the figure, so that the gearshift forks and transmission gears can be installed easily.

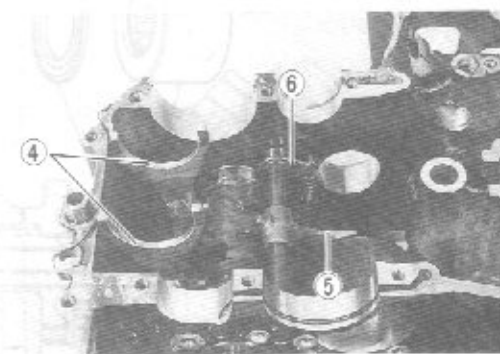

- Fit the bearing pins (7) and C-rings (8) on the upper crankcase.
- Fit the oil jets (9) and (10).

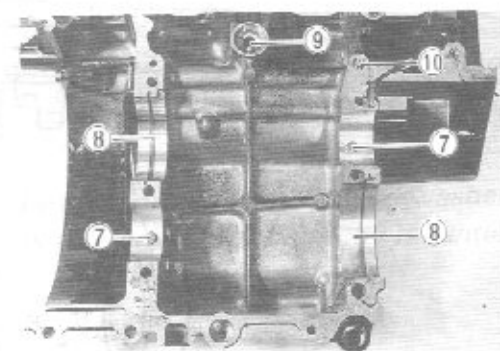

- Install both of the countershaft assembly and driveshaft assembly on the upper crankcase.

### NOTE:

- \* Be sure to install the bearing dowel pins (11) in their respective positions.
- \* Install the countershaft end cap to the position (12).
- \* Make sure that the countershaft turns freely while holding the driveshaft. If not, shift the gear which is engaged to the neutral position.

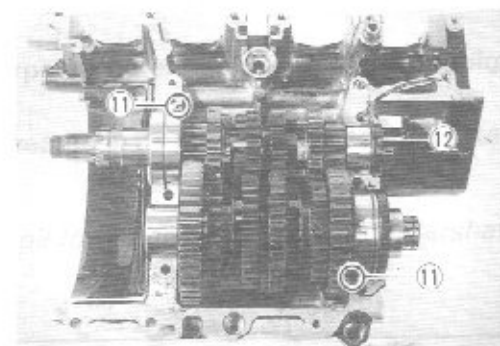

- When fitting the crankshaft journal bearings to the upper and lower crankcases, be sure to fix the stopper part ① first and press the other end.

**CAUTION:**

Do not touch the bearing surface with your hands. Grasp by the edge of the bearing shell.

- Install the cam chain guide ② and two dampers ③ properly.

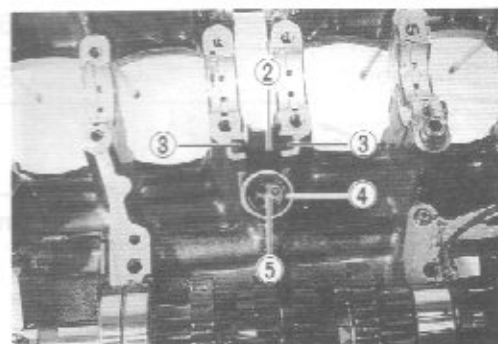
**NOTE:**

Be sure to face the arrow mark on the damper to the front and rear, not to the right and left.

- Install the oil gallery plate ④ and new O-ring ⑤.

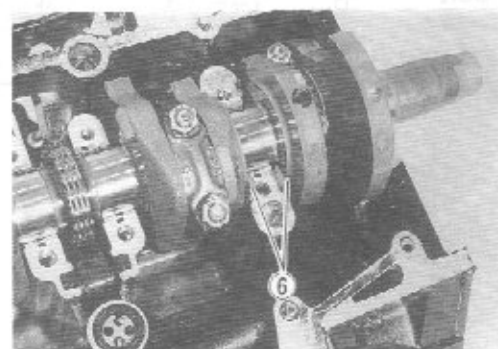

- Before installing the crankshaft, apply SUZUKI MOLY PASTE to each journal bearing.

**99000-25140: SUZUKI MOLY PASTE**

- Install the crankshaft with the cam chain to the upper crankcase.
- Insert the right and left thrust bearings ⑥ with oil grooved facing the crank web.
- Clean the mating surface of the crankcases before matching the upper and lower ones.
- Install the dowel pins to the upper crankcase.
- Apply SUZUKI BOND NO. 1207B to the mating surface of the lower crankcase in the following procedure.

**99000-31140: SUZUKI BOND NO. 1207B****NOTE:**

Use of SUZUKI BOND NO. 1207B is as follows:

- \* Make surfaces free from moisture, oil, dust and other foreign materials.
- \* Spread on surfaces thinly to form an even layer, and assemble the cases within few minutes.
- \* Take extreme care not to apply any BOND NO. 1207B to the bearing surfaces.
- \* Apply to distorted surface as it forms a comparatively thick film.

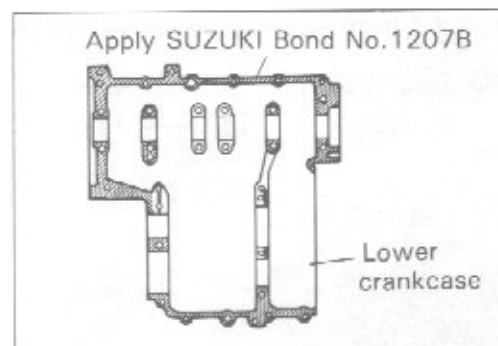

- Locate two allen bolts at position (B) and ten 8-mm bolts.
- Tighten the crankshaft tightening 8-mm bolts in the ascending order of numbers assigned to these bolts, tightening each bolt a little at a time to equalize the pressure. Tighten the lower and upper crankcase securing bolts to the specified torque.

**Initial tightening torque**

	N·m	kg-m	lb-ft
6 mm bolt	6	0.6	4.5
8 mm bolt	13	1.3	9.5

**Final tightening torque**

		N·m	kg-m	lb-ft
		8-12	0.8-1.2	6.0 8.5
6 mm bolt	(A)	12-16	1.2-1.6	8.5-11.5
	(B)	14-18	1.4 1.8	10.0-13.0
8 mm bolt		20-24	2.0-2.4	14.5-17.5

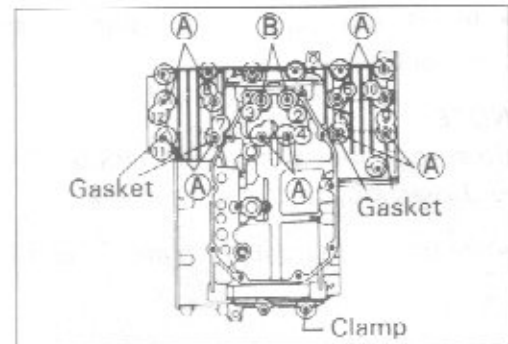
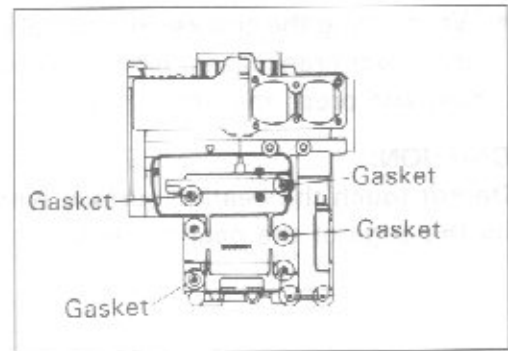

- Tighten the main oil gallery plug to the specified torque.

**Tightening torque: 30-40 N·m**  
(3.0-4.0 kg-m, 21.5-29.0 lb-ft)

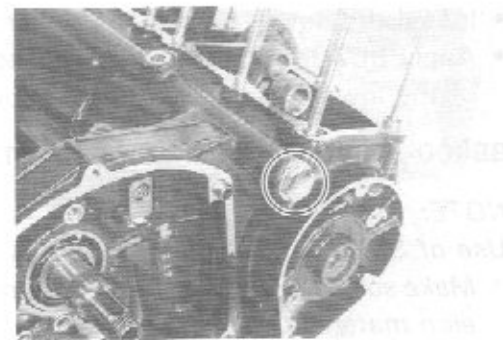

- Apply THREAD LOCK "1342" to the bearing retainer screws (1) and tighten them.
- Install the oil gallery plate (2).

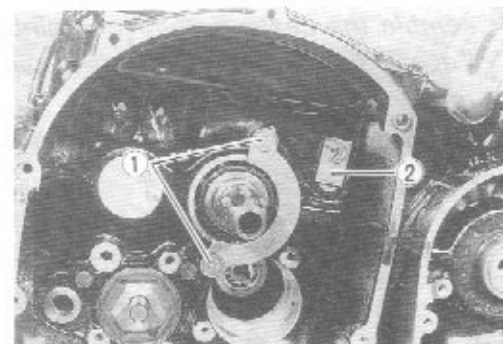

- Tighten the oil pressure regulator to the specified torque.

**Tightening torque: 25–30 N·m**

**(2.5–3.0 kg-m, 18.0–21.5 lb-ft)**

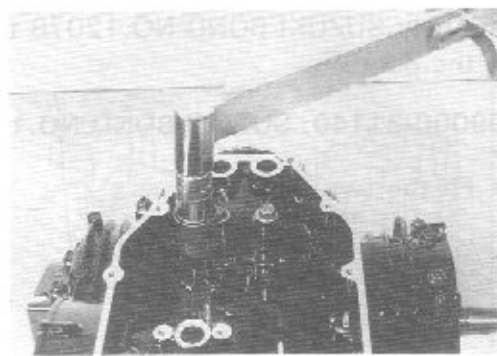

- Fit a new O-ring and install the oil sump filter.

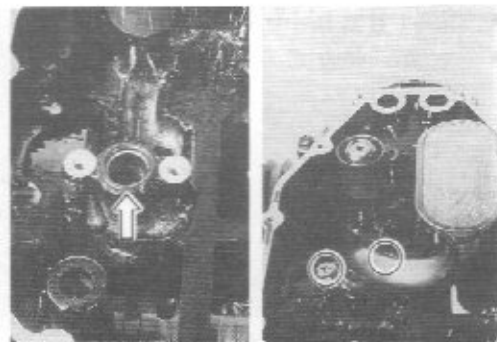

- Degrease the tapered portion of the crankshaft and also the rotor.

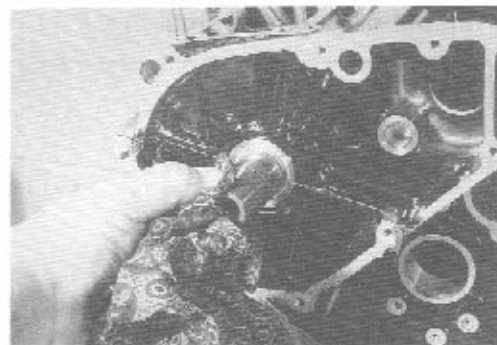

- Apply THREAD LOCK SUPER "1305" to the rotor bolt and tighten it to the specified torque with the special tool.

**99000-32100: THREAD LOCK SUPER "1305"**

**Tightening torque: 110–130 N·m**

**(11.0–13.0 kg-m, 79.5–94.0 lb-ft)**

**09930-44913: Rotor holder**

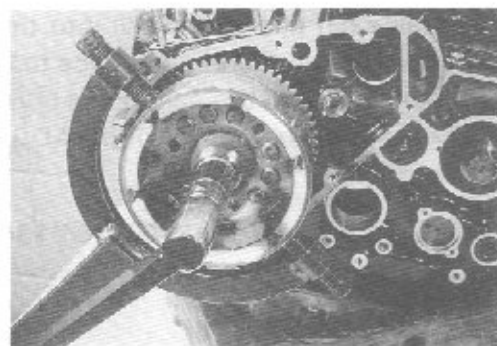
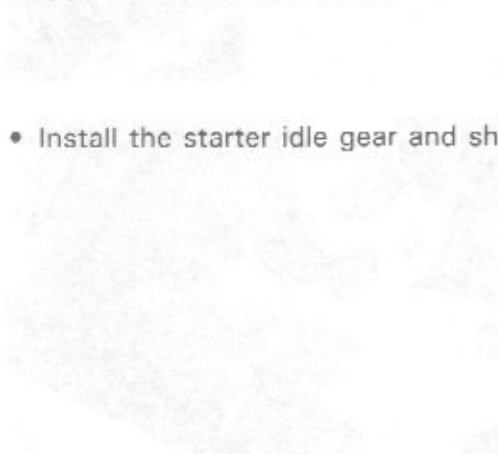

- Install the starter idle gear and shaft.

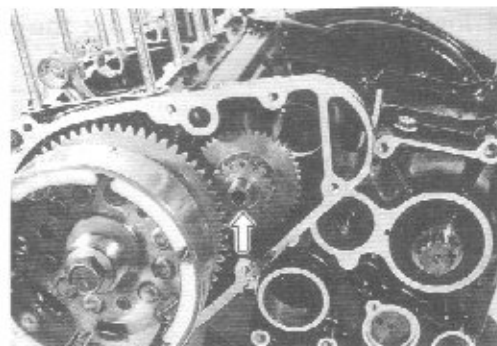



- Apply SUZUKI BOND NO.1207B to the (A) as shown in the photo.

99000-31140: SUZUKI BOND NO.1207B

- Fit the two dowl pins.

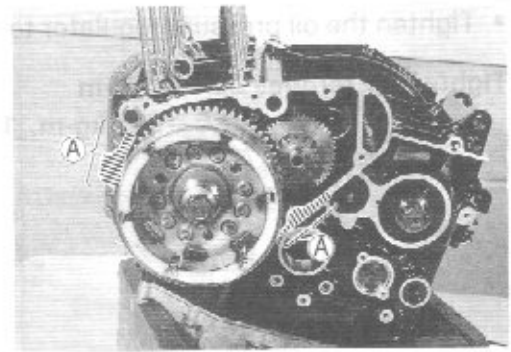

- Insert the neutral indicator spring (1) and contact (2).
- Fit the new O-ring (3).

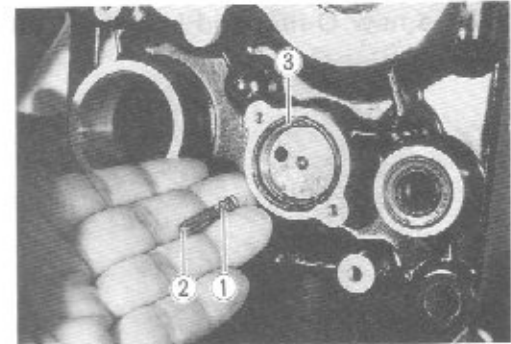

- Install the water pump.

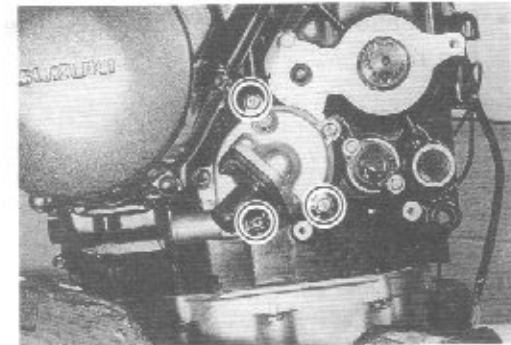

- Install each gearshift pawl into the cam driven gear. The large shoulder (A) must face to the outside as shown.
- When installing the cam guide (4) and pawl lifter (5), apply a small quantity of THREAD LOCK "1342" to the screws.

99000-32050: THREAD LOCK "1342"

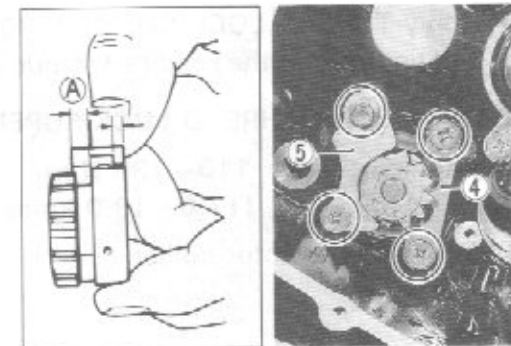

- Install the washer (6) and fix the clip (7).

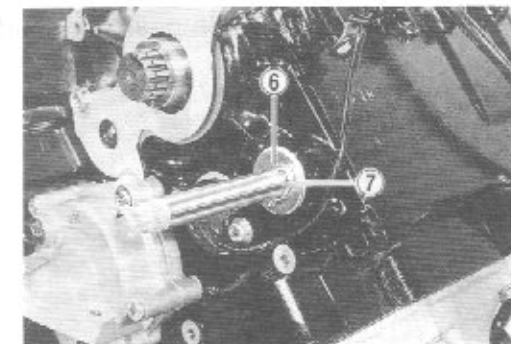

- When installing the oil pump, align the protrusion of the water pump shaft with slit of the oil pump shaft.

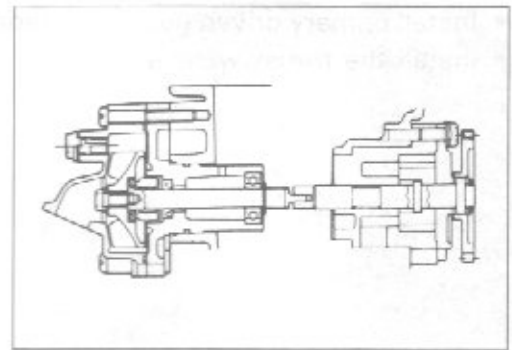

- Install the washer (1), pin (2) and oil pump drive gear (3).
- Fix the oil pump drive gear with a circlip.

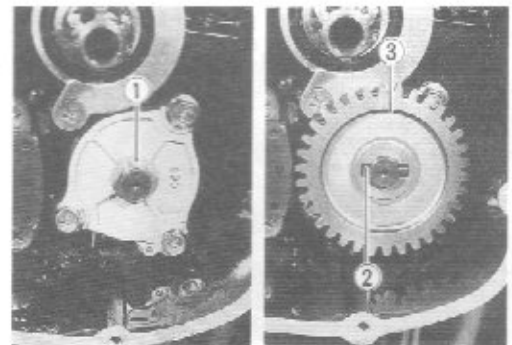

## CLUTCH

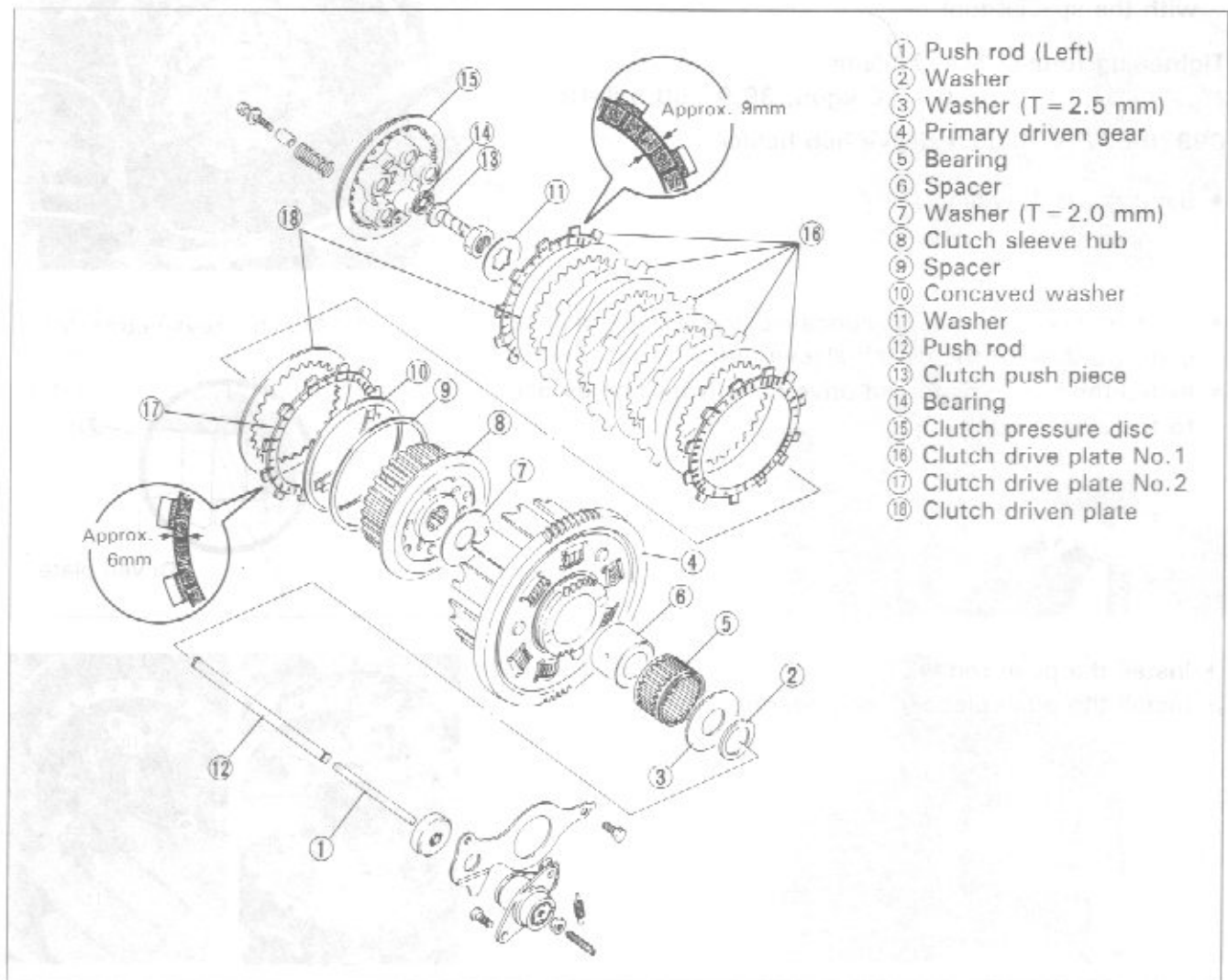

- Install primary driven gear (1), bearing (2) and spacer (3).
- Install the thrust washer (4).

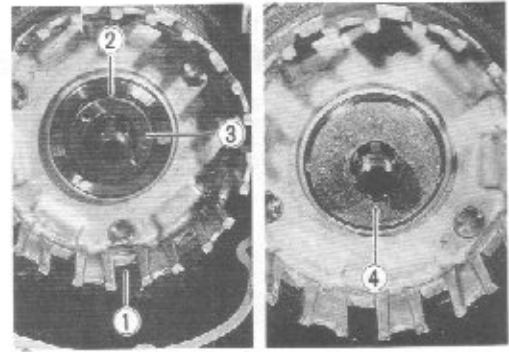

- When installing the lock washer (5), align the groove of the lock washer with rib of clutch sleeve hub.

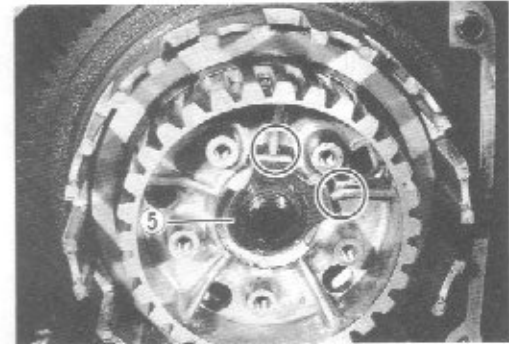

- Tighten the clutch sleeve hub nut to the specified torque with the special tool.

**Tightening torque: 50–70 N·m  
(5.0–7.0 kg-m, 36.0–50.5 lb-ft)**

**09920-53710: Clutch sleeve hub holder**

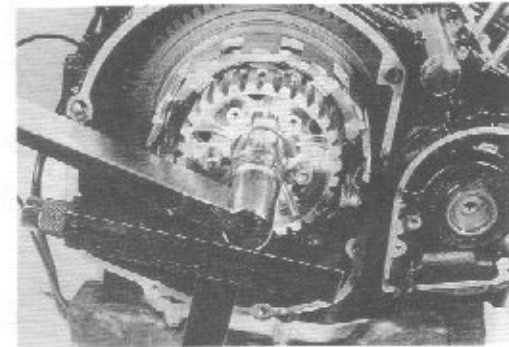

- Bend the lock washer.

- Install the seat washer (6), concaved washer (7) and drive plate No.2 (8) to the clutch sleeve hub.
- Install the driven plate and drive plate No.1 one by one to the sleeve hub.

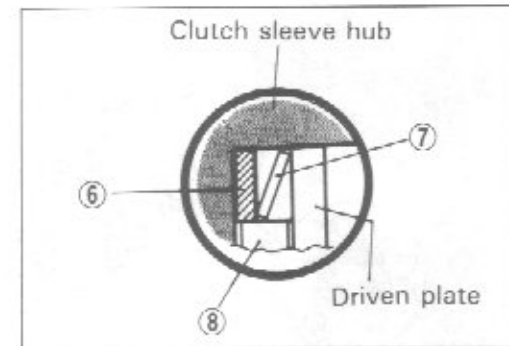

- Install the push rod (9).
- Install the push piece (10) and bearing (11).

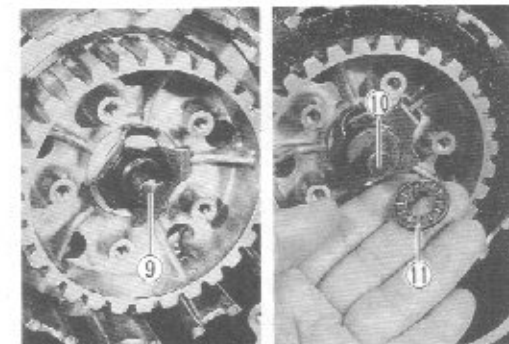

- Tighten the clutch spring set bolts diagonally with the special tool.

09910-20115: Conrod holder

- Fit the two dowel pins.
- Coat SUZUKI BOND NO.1207B lightly to the portion around mating surface between crankcases.

99000-31140: SUZUKI BOND NO.1207B

- Tighten the clutch cover bolts securely.

**NOTE:**

Fit up the two gaskets to the clutch cover bolts **A** correctly as shown in the figure.

**CAUTION:**

Use only new gasket to prevent oil leakage.

## SIGNAL GENERATOR

- Install the signal generator stator with three screws.
- Make sure to fit the slot **①** on the back surface of the signal generator rotor over the locating pin **②** at the end of crankshaft.

- Tighten the signal generator rotor bolt to the specified torque with the special tool.

Tightening torque: 23–28 N·m  
(2.3–2.8 kg·m, 16.5–20.0 lb-ft)

09910-20115: Conrod holder

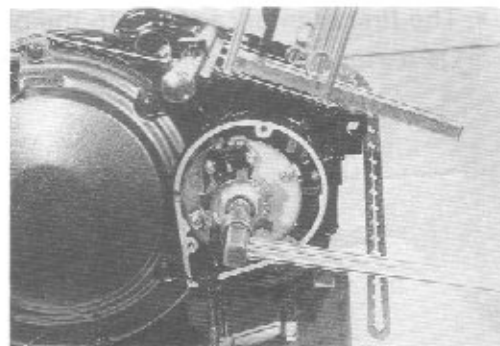
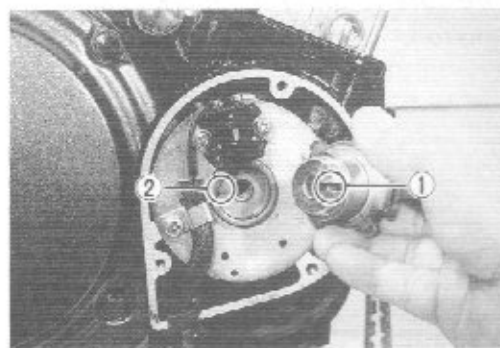
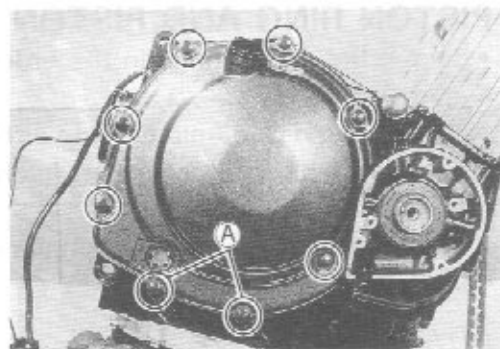
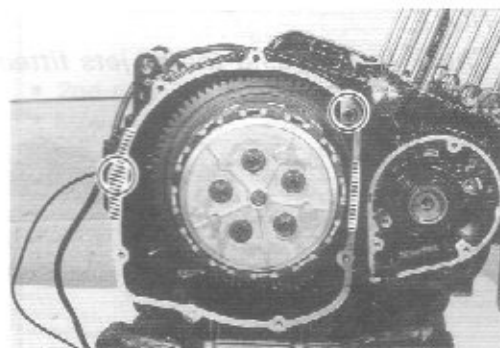
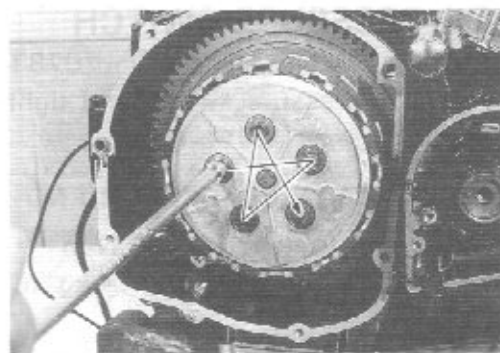

## OIL PRESSURE SWITCH

- Apply SUZUKI BOND NO.1207B to the thread portion of the oil pressure switch and tighten it to the specified torque.

99000-31140: SUZUKI BOND NO.1207B

Tightening torque: 12–15 N·m  
(1.2–1.5 kg·m, 8.5–11.0 lb·ft)

### NOTE:

Check for clogging the oil jets fitted on crankcase.

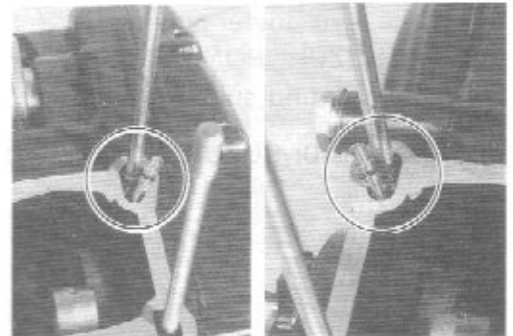
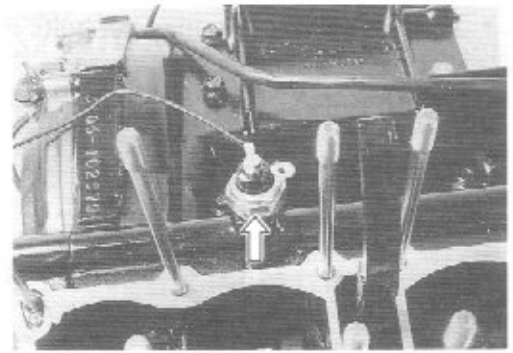

## PISTON RING AND PISTON

- Install the piston rings in the order of oil ring, 2nd ring and top ring.
- Top ring and 2nd (middle) ring differ in the shape of ring face, and the face of top ring is chrome-plated whereas that of ring is not.
- Top and 2nd (middle) rings have letter "R" and "RN" marked on the rings.

### NOTE:

Be sure to bring the marked side to top when fitting to the piston.

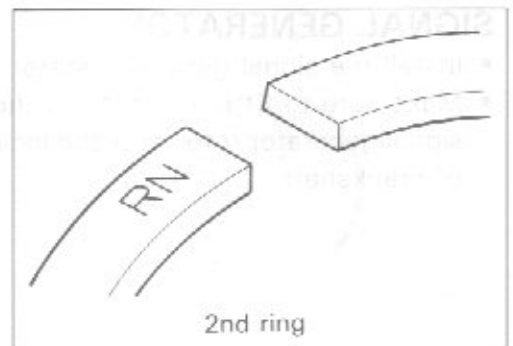
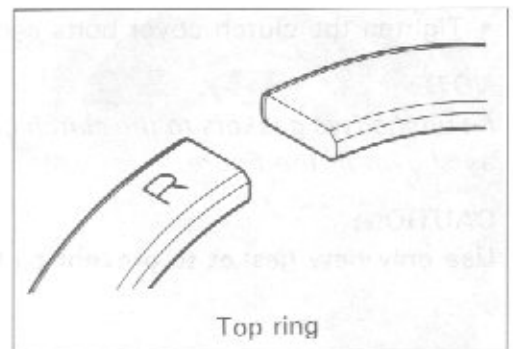

- The first member to go into the oil ring groove is spacer ①. After placing spacer, fit the two side rails ②.

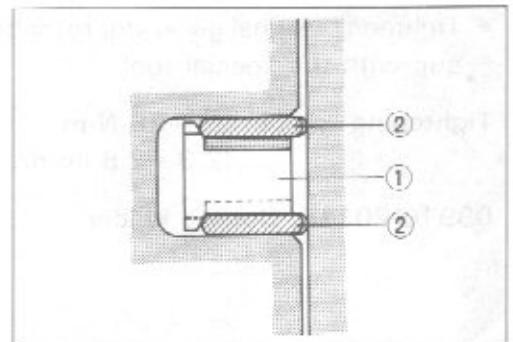

**CAUTION:**

When installing the spacer, be careful not to allow its two ends to overlap in the groove.

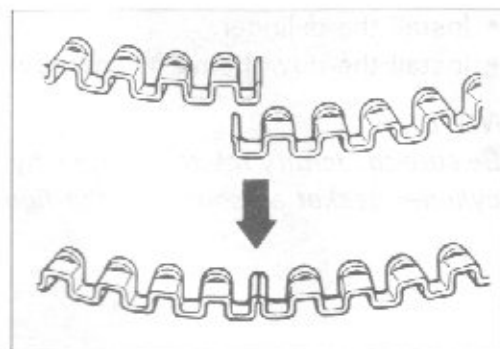

- Position the gaps of the three rings as shown. Before inserting each piston into the cylinder, check that the gaps are so located.

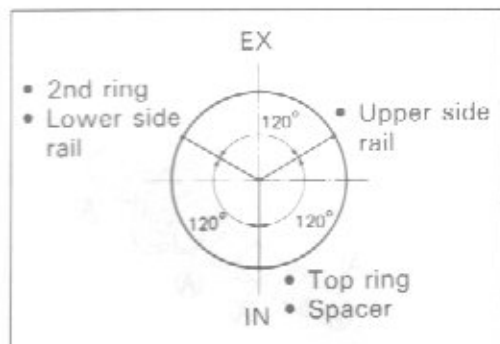

- The piston is in correct position when its arrow ① (on the top) points forward.
- Be sure to install the pistons in the cylinder from which they were taken out in disassembly, referring to the letter mark, "1" through "4", scribed on the piston.
- Have each piston pin oiled lightly before installing it.
- Place a cloth beneath the piston, and install the circlip ②.

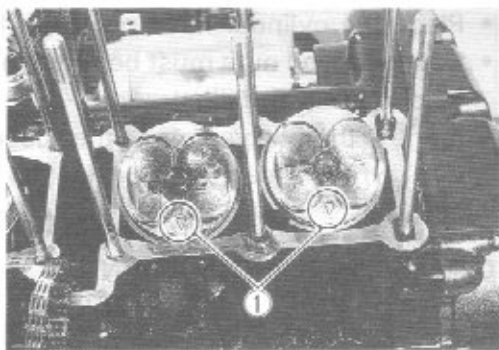
**NOTE:**

Be sure to use new circlips.

- Before assembling on the cylinder block, oil the big and small ends of each conrod and also the sliding surface of each piston.

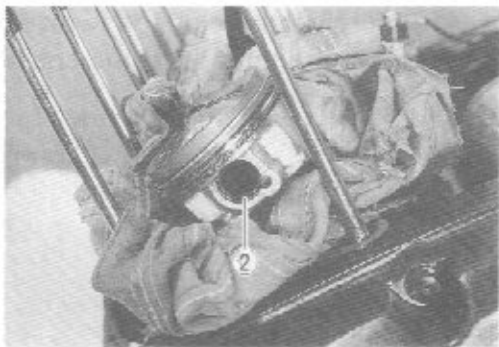

- Place the dowel pins and new cylinder gasket on the crankcase.

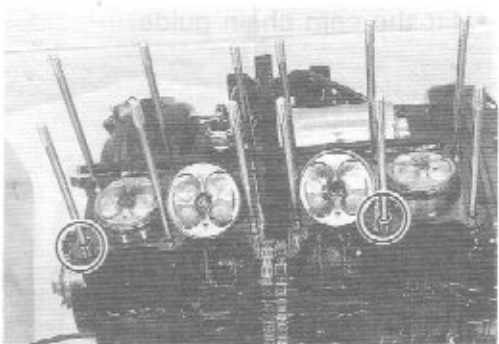

- Install the cylinder.
- Install the dowel pins ① and new gasket.

**NOTE:**

Be sure to identify the top surface by "UP" mark ② on the cylinder gasket as shown in the figure.

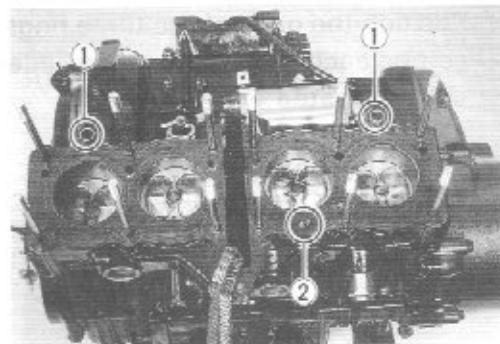
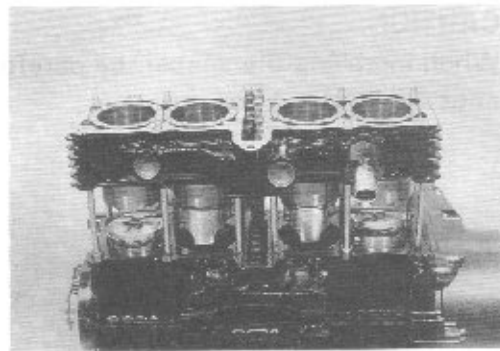

- Place the cylinder head on the cylinder.
- Cylinder head nuts must be fitted in the correct positions, as shown in the illustration.
- Tighten the twelve nuts to the specified torque with a torque wrench sequentially in the ascending order of numbers.

**Cylinder head nut: 15–19 N·m**  
(1.5–1.9 kg-m, 11.0–13.5 lb-ft)

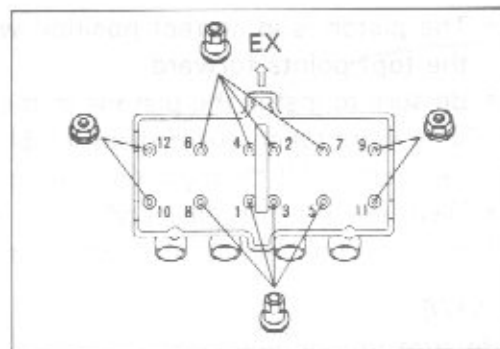

- After firmly tightening the twelve nuts, install one 6-mm bolt (A) and tighten it to the specified torque.

**Cylinder head bolt: 8–12 N·m**  
(0.8–1.2 kg-m, 6.0–8.5 lb-ft)

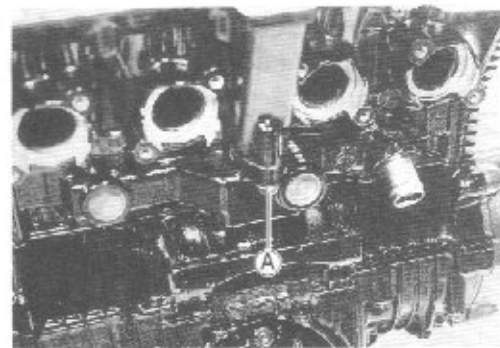

- Fit the cam chain guide.

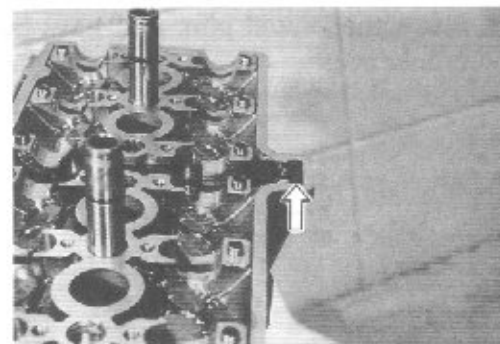

- While holding down the cam chain, rotate the crankshaft in normal direction to bring the "T" mark on the rotor to the center of pick up coil.

**CAUTION:**

To turn over crankshaft, torque the nut with a 22 mm wrench. Never try to rotate the crankshaft by putting a 6 mm T-type wrench.

**NOTE:**

- \* Just before placing the camshaft on the cylinder head, apply SUZUKI MOLY PASTE to its journals, fully coating each journal (A) with the paste taking care not to leave any dry spot.
- \* Apply engine oil to the camshaft journal holders.

**99000-25140: SUZUKI MOLY PASTE**

- The exhaust camshaft can be distinguished from that of the intake by the embossed letter "E" (for exhaust) as against letter "D" (for intake). Similarly, the right end can be distinguished by the notch (1) at the right end.

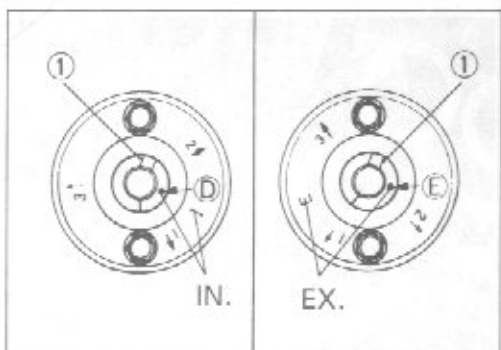
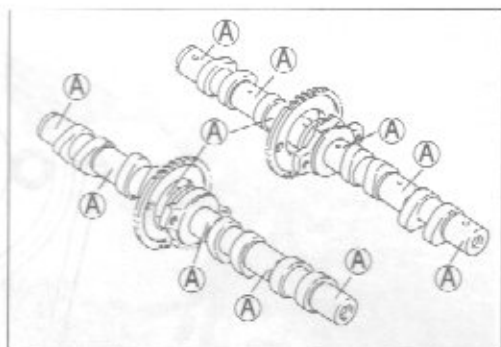

- With "T" mark accurately lined up with the timing mark, hold the crankshaft steady and lightly pull up the chain to remove the slack between the crank sprocket and exhaust sprocket.
- Exhaust sprocket bears an arrow marked "1" indicated as (2). Turn over the exhaust camshaft so that the arrow points flush with the gasketed surface of the cylinder head. Engage the cam chain with this sprocket.

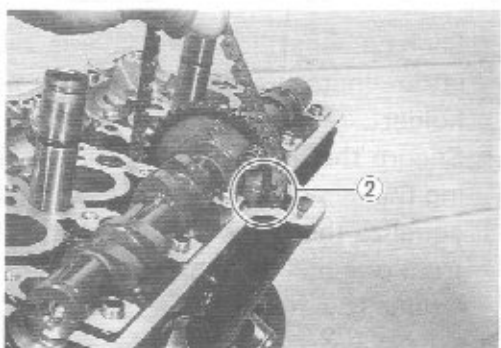

- The other arrow marked "2" is now pointing straight upward. Count the chain roller pins toward the intake camshaft, starting from the roller pin directly above this arrow marked "2" and ending with the 16th roller pin. Engage the cam chain with intake sprocket, locating the 16th pin at the above the arrow marked "3" on the intake sprocket.

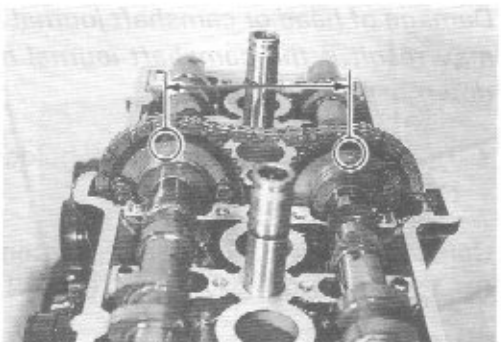



**NOTE:**

The cam chain is now riding on all three sprockets. Be careful not to disturb the crankshaft until the camshaft journal holder and cam chain tensioner are secured.

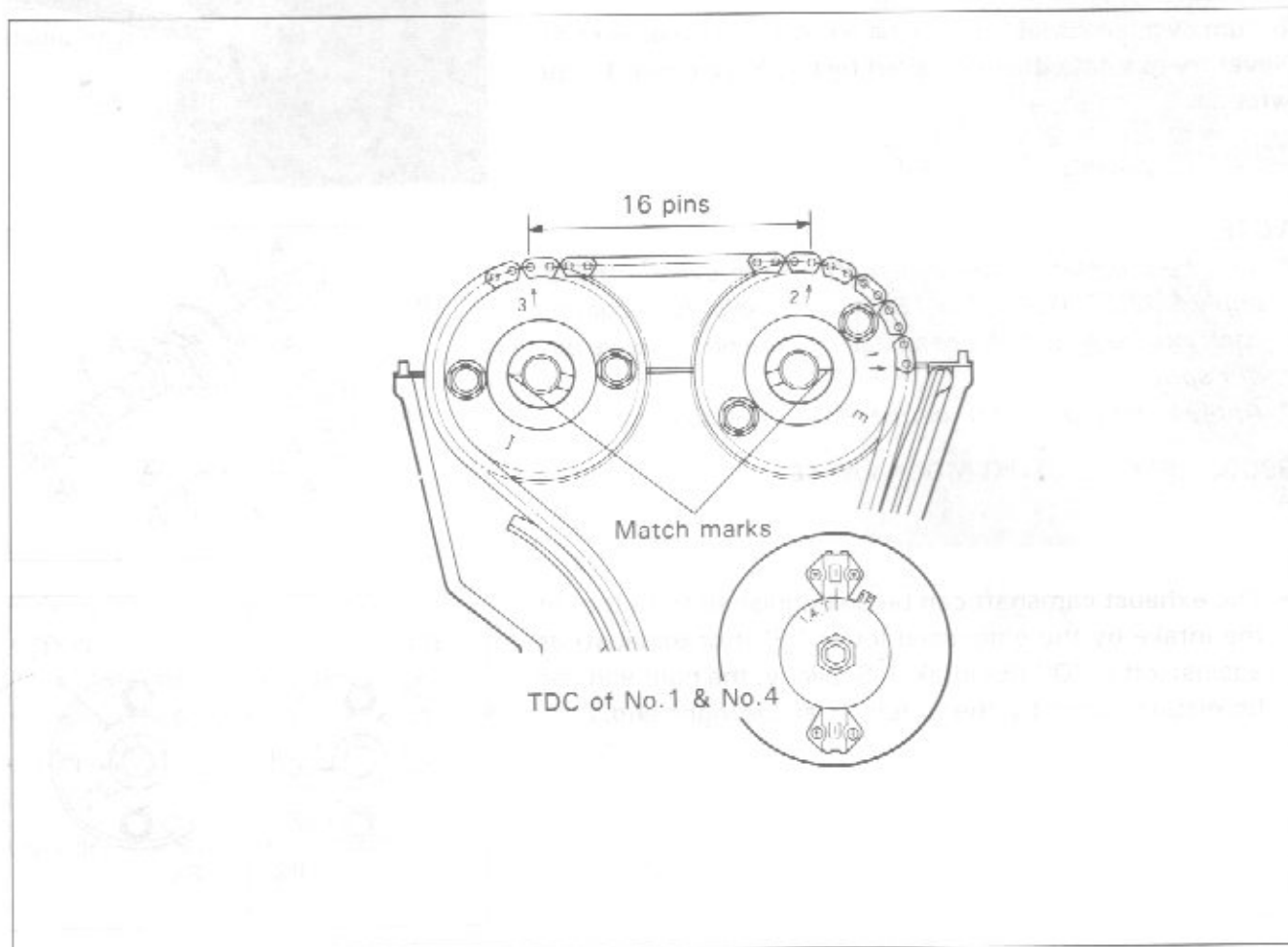

- Each camshaft journal holder is identified with a cast-on letter. Install the dowel pins to each camshaft journal holder.
- Secure the camshaft journal holders evenly by tightening the camshaft journal holder bolts sequentially. Try to equalize the pressure by moving the wrench diagonally from one bolt to another and from one camshaft journal holder to another, to push shafts down evenly.

**NOTE:**

Damage of head or camshaft journal holder thrust surfaces may result if the camshaft journal holders are not drawn down evenly.

- Tighten the camshaft journal holder bolts to the specified torque.

**Camshaft journal holder bolt tightening torque**  
8–12 N·m (0.8–1.2 kg·m, 6.0–8.5 lb·ft)

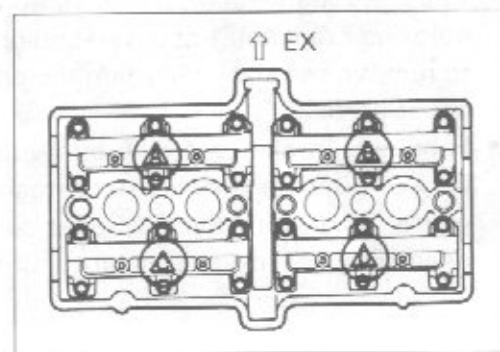

- Pour about 50 ml (1.69/1.76 US/Imp oz) of engine oil in each oil pocket in the head.

## CAM CHAIN TENSIONER

- When installing the cam chain tensioner, turn the slotted end of the chain tensioner to lock it with a screwdriver in the clockwise direction.
- Install the chain tensioner on the cylinder.

**Tightening torque: 6–8 N·m**  
(0.6–0.8 kg·m, 4.5–6.0 lb·ft)

- Turn back and pull out the screwdriver from the chain tensioner.

### NOTE:

The cam chain tensioner is maintained at the proper tension by an automatically adjusted tensioner. Before installing the chain tensioner, inspect the push rod smooth movement.

### CAUTION:

After installing the cam chain tensioner, check to be sure that the tensioner work properly by checking the slack of cam chain.

### NOTE:

Turn the crankshaft and check that all the moving parts such as cam follower, camshaft, work properly.

### CAUTION:

Be sure to check and adjust the tappet clearance. (Refer to page 2-5.)

- Before installing the cylinder head cover gaskets on the cylinder head cover, apply SUZUKI BOND NO. 1207B to the groove of the head cover as shown in the figure.

99000-31140: SUZUKI BOND NO.1207B

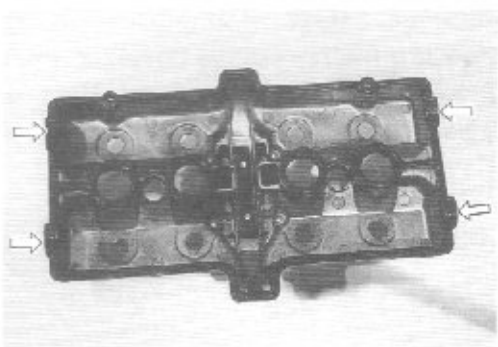
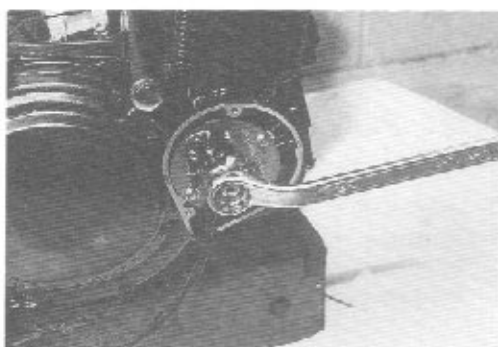
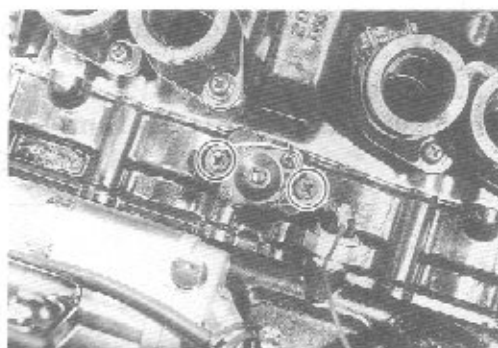
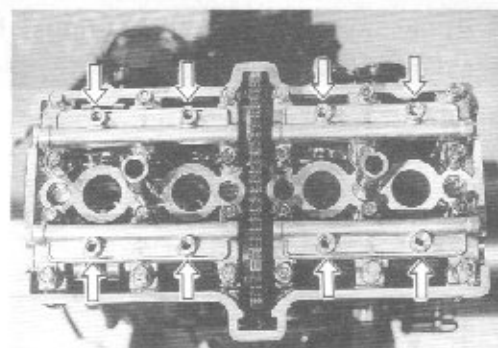

- Apply engine oil to the O-rings, before installing the cylinder head cover.

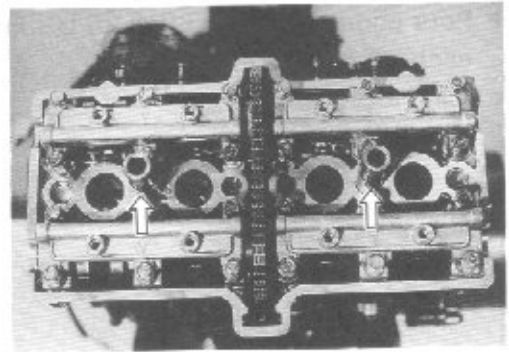

- Apply engine oil to the cylinder head cover (A) as shown in the illustration.

**CAUTION:**

Replace the gaskets with new ones to prevent oil leakage.

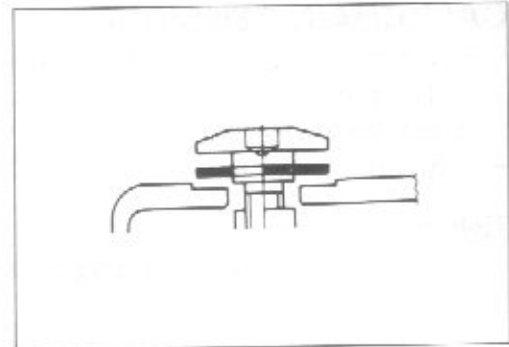

- Tighten the cylinder head cover bolts to the specified torque.

**Tightening torque: 13–15 N·m  
(1.3–1.5 kg-m, 9.5–11.0 lb-ft)**

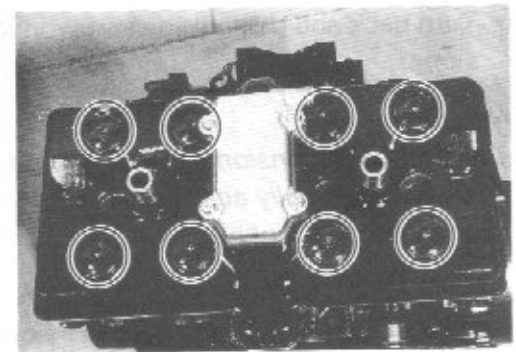

# FUEL AND LUBRICATION SYSTEM

## CONTENTS

<b>FUEL COCK</b> .....	<b>4- 1</b>
<b>FUEL PUMP AND FUEL PUMP RELAY</b> .....	<b>4- 1</b>
<b>FUEL TANK</b> .....	<b>4- 3</b>
<b>CARBURETOR</b> .....	<b>4- 5</b>
<b>SPECIFICATIONS</b> .....	<b>4- 6</b>
<b>I.D. NO. LOCATION</b> .....	<b>4- 6</b>
<b>REMOVAL AND DISASSEMBLY</b> .....	<b>4- 7</b>
<b>INSPECTION</b> .....	<b>4- 9</b>
<b>REASSEMBLY AND REMOUNTING</b> .....	<b>4- 9</b>
<b>BALANCE OF CARBURETORS</b> .....	<b>4-11</b>
<b>LUBRICATION SYSTEM</b> .....	<b>4-13</b>

## FUEL COCK

### REMOVAL

- Turn the fuel cock lever to "OFF" position and disconnect the fuel hose from the fuel cock.
- Place a clean oil pan under the fuel cock assembly, turn the fuel cock lever to "RES" position and drain fuel.
- Remove the fuel cock assembly.

#### WARNING:

Gasoline is very explosive.  
Extreme care must be taken.

### CLEANING

Dust from the fuel tank tends to build up in the filter which, when the filter has been neglected for a long period, inhibits the flow of fuel.

Remove the dust from the filter using compressed air.

#### WARNING:

Gasket must be replaced with a new one to prevent fuel leakage.

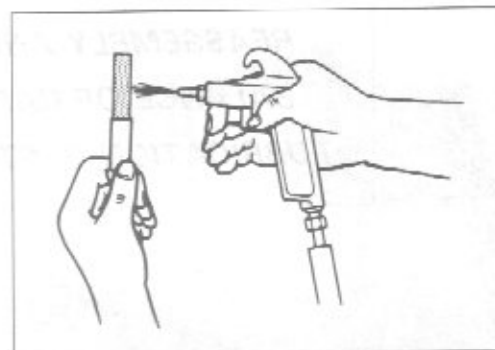
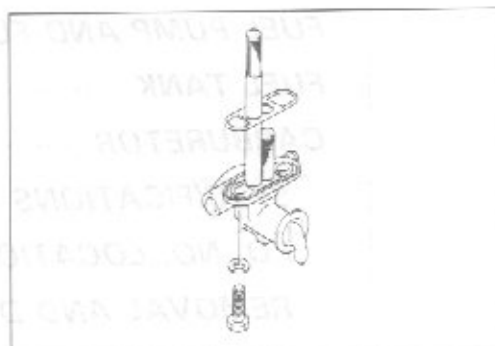
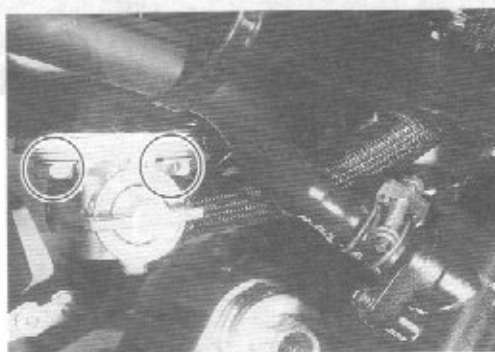

## FUEL PUMP AND FUEL PUMP RELAY

### FUEL PUMP REMOVAL

- Remove the seat and left frame cover. (Refer to page 3-4.)
- Turn the fuel cock lever to "OFF" position.
- Remove the fuel pump.



### INSPECTION

Measure the resistance between the fuel pump lead wires. If the resistance noted to show infinity or too low a resistance value, it must be replaced.

Resistance (S.T.D.): 1–3  $\Omega$

09900-25002: Pocket tester

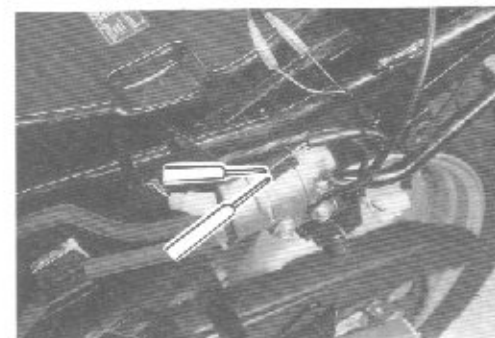

Place the fuel pump and battery as shown in the figure. Measure the amount of kerosene discharged and conduct a test on the fuel pump.

Attach fuel pump harness B/Br to the battery  $\oplus$  terminal and B/W to the battery  $\ominus$  terminal. Measure the discharge amount from the fuel pump for 1 minute using a measuring cylinder.

**Discharge amount: Over 600 ml (1.27/1.06 US/lmp pt)**

If the discharge amount is less than the specification, it means that the fuel pump is defective. Replace the fuel pump with a new unit.

**WARNING:**

**Do not use gasoline, which is extremely flammable and explosive.**

**NOTE:**

*The battery must be fully charged.*

*Upon completion of the test, all the kerosene should be drained from the fuel pump.*

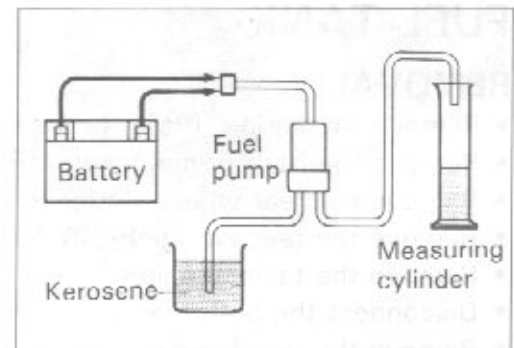

## FUEL PUMP RELAY INSPECTION

- Remove the seat and left frame cover. (Refer to page 3-4.)
- Remove the fuel pump relay.

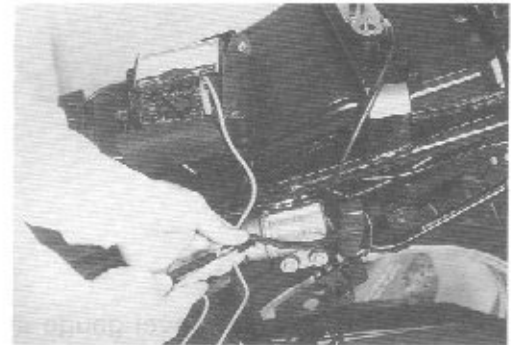

**First:**

Check the inspection between ③ and ④ terminals with pocket tester.

**Second:**

Apply DC 12 volts to ① and ② terminals,  $\oplus$  to ① and  $\ominus$  to ②, and check the continuity between ③ and ④ with a pocket tester. If there is no continuity, replace it with a new one.

**09900-25002: Pocket tester**

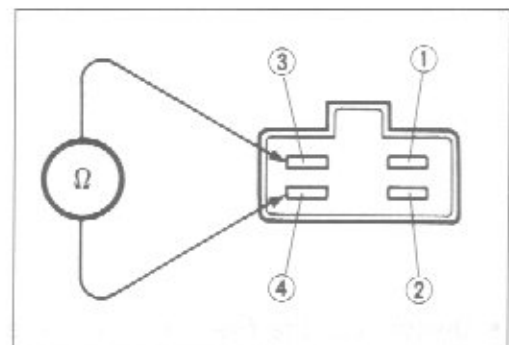

## FUEL TANK

### REMOVAL

- Remove the fairing. (Refer to page 7-1.)
- Remove the both frame covers. (Refer to page 3-4.)
- Remove the rear wheel. (Refer to page 7-28.)
- Remove the rear swingarm. (Refer to page 7-36.)
- Remove the tail/brake light.
- Disconnect the both rear turn signal light lead wire.
- Remove the rear fender.



- Disconnect the fuel tank lid solenoid lead wire.
- Remove the fuel tank lid bracket.

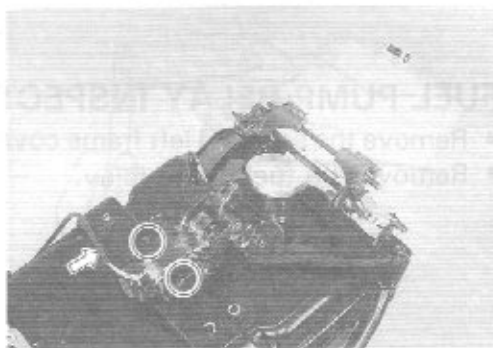

- Disconnect the fuel level gauge switch lead wires.



- Disconnect the fuel hoses and breather hose.

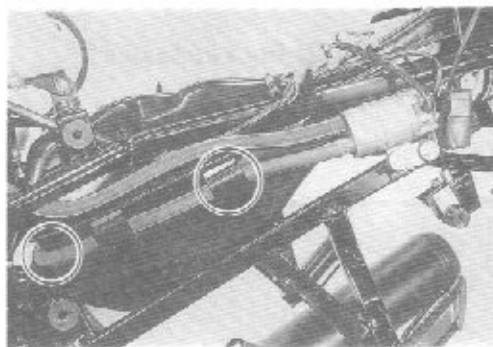

- Remove the fuel tank by removing the mounting bolts.

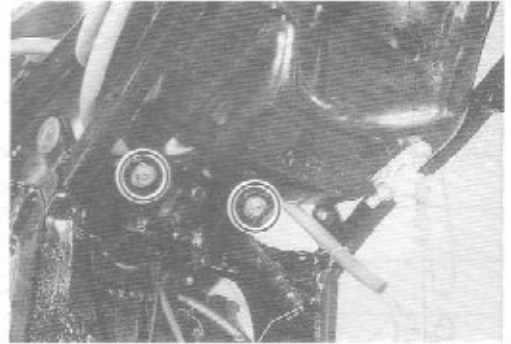
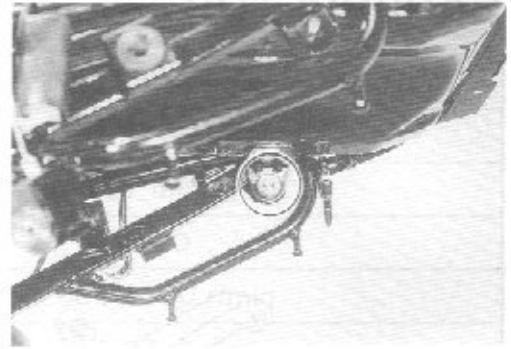

## REMountING

Remount the fuel tank in the reverse order of removal.



## CARBURETOR

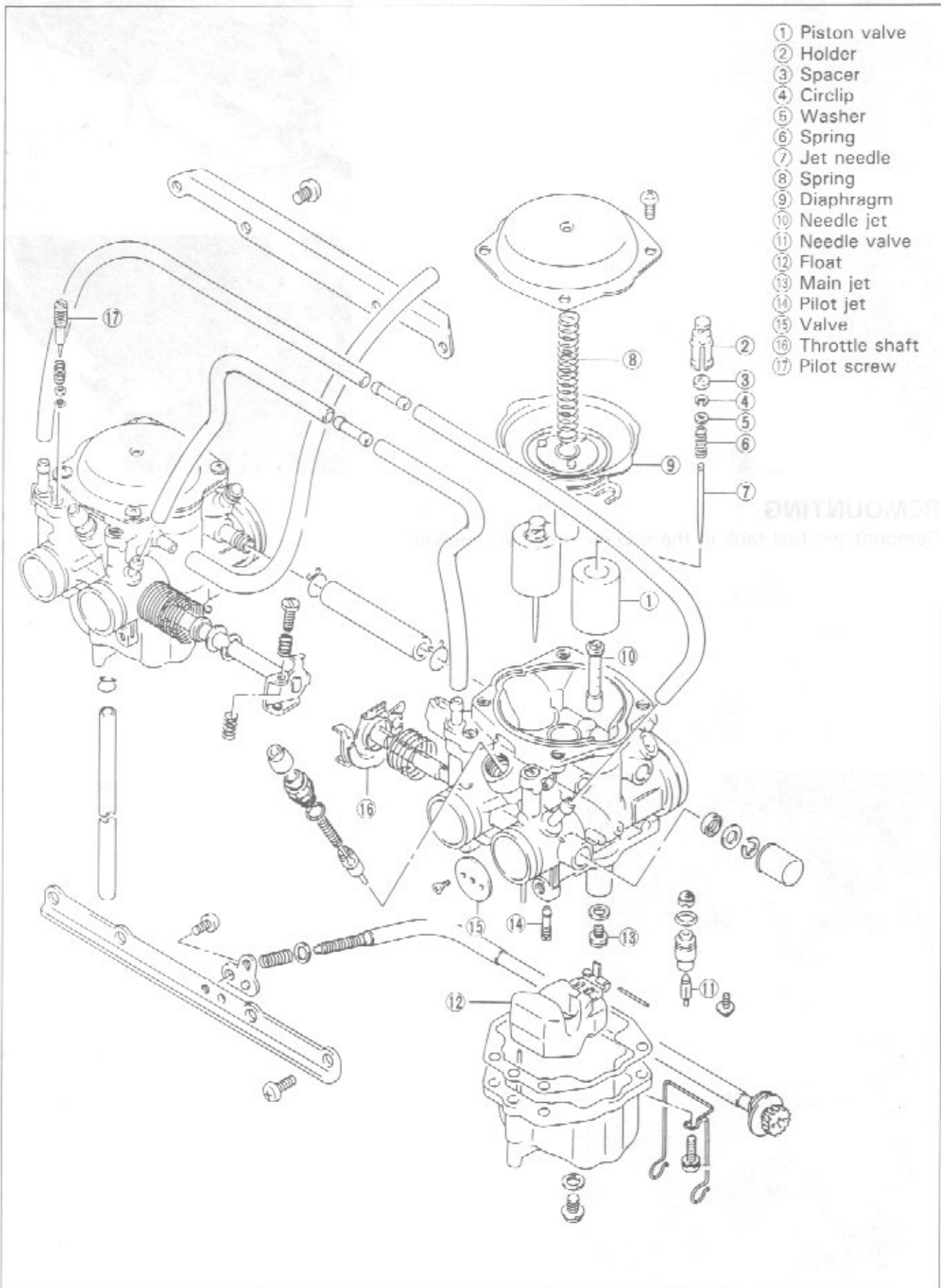

## SPECIFICATIONS

ITEM	SPECIFICATIONS
Carburetor	MIKUNI BSW27
Bore size	27 mm
I.D. No.	24D0
Idle r/min.	1 600 ± 100 r/min
Float height	20.5 ± 1.0 mm
Main jet (M.J.)	# 90
Main air jet (M.A.J.)	1.4 mm
Jet needle (J.N.)	5D52-3rd
Needle jet (N.J.)	O-1
Throttle valve (Th.V.)	# 85
Pilot jet (P.J.)	# 30
By-pass (B.P.)	0.8, 0.8, 0.8 mm
Pilot outlet (P.O.)	0.9 mm
Valve seat (V.S.)	1.0 mm
Starter jet (G.S.)	# 22.5
Pilot screw (P.S.)	PRE-SET (1½ turns back)
Throttle cable play	0.5–1.0 mm (0.02–0.04 in)
Choke cable play	0.5–1.0 mm (0.02–0.04 in)

## I.D. NO. LOCATION

Each carburetor has I.D. Number ① printed on the carburetor body according to its specifications.

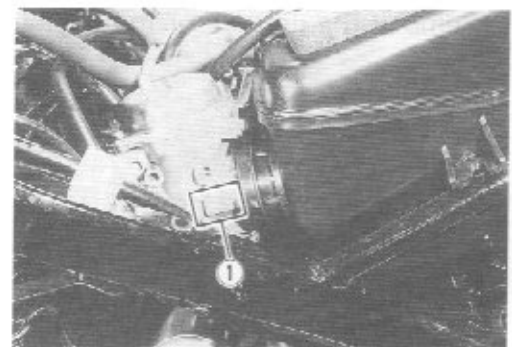

## REMOVAL AND DISASSEMBLY

- Remove the carburetor. (Refer to page 3-6.)
- Disconnect the hoses.

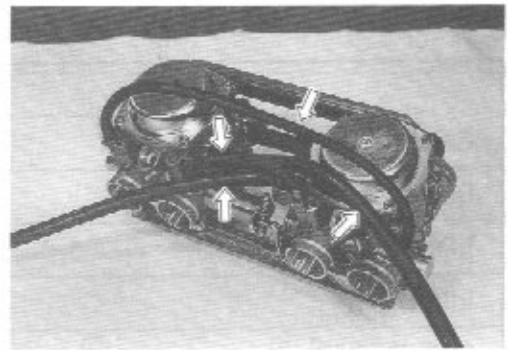

- Remove the carburetor set upper plate.

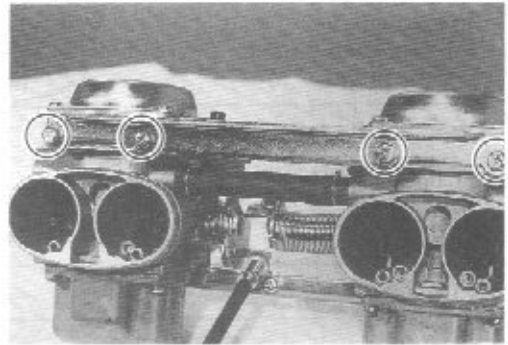

- Remove the carburetor set lower plate.

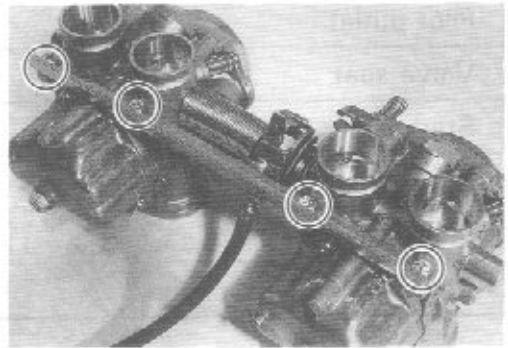

- Remove the carburetor top cap.

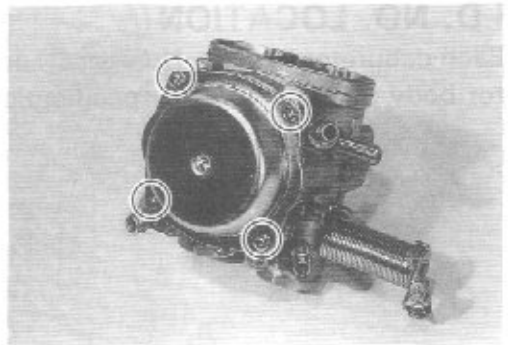

- Remove the piston valve return spring, diaphragm and piston valve.

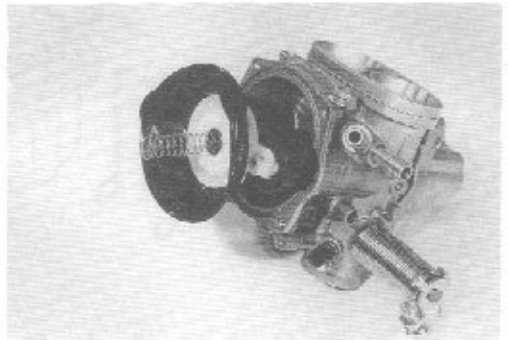

- Remove the float chamber.

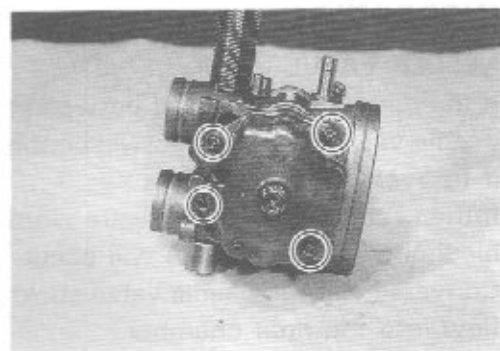

- Remove the float assembly by removing the pin ①.



- Remove the main jets ②, needle jets ③ and pilot jets ④.

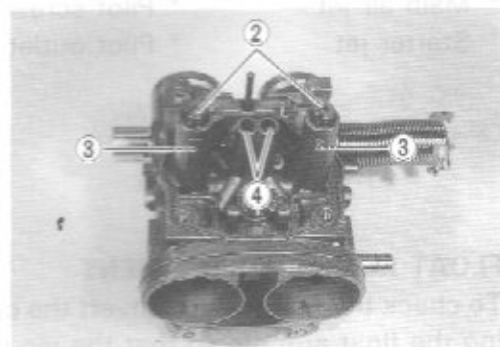

- Remove the throttle valve securing screws.

**CAUTION:**

These screws are locked by punching these ends. Once removing the screws, replace with new ones.

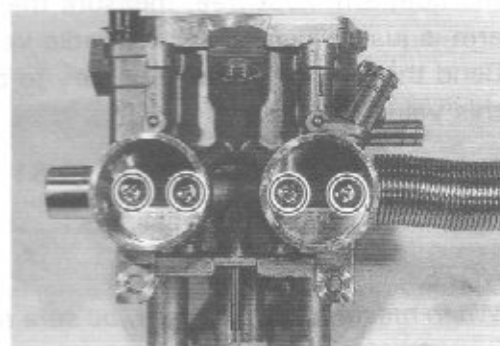

- Remove the cap and "E" ring ⑤.
- Remove the throttle shaft.

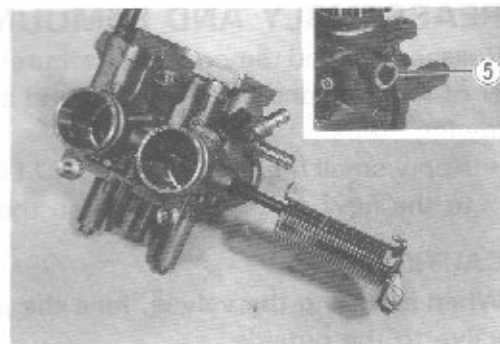

## INSPECTION

### NEEDLE VALVE

If foreign matter is caught between the valve seat and the needle valve, the gasoline will continue flowing and cause it to overflow.

If the seat and needle valve are worn beyond the permissible limits, similar trouble will occur.

Conversely, if the needle valve sticks, the gasoline will not flow into the float chamber.

Clean the float chamber and float part with gasoline. If the needle is worn as shown in the illustration, replace it together with a valve seat.

Clean the fuel passage of the mixing chamber with compressed air.

For any damage or clogging, check to see the following items:

- |                 |                                 |
|-----------------|---------------------------------|
| * Pilot jet     | * Float                         |
| * Main jet      | * Diaphragm                     |
| * Pilot air jet | * Gasket and O-ring             |
| * Main air jet  | * Pilot screw bleeding hole     |
| * Starter jet   | * Pilot outlet and bypass holes |

### FLOAT HEIGHT ADJUSTMENT

To check the float height, invert the carburetor body, holding the float arm pin so that the pin will not slip off. With the float arm kept free, measure the height (A) while float arm is just in contact with needle valve with a calipers. Bend the tongue (1) as necessary to bring the height (A) to this value.

**Float height:  $20.5 \pm 1.0$  mm ( $0.81 \pm 0.04$  in)**

**09900-20101: Vernier calipers**

#### NOTE:

*When measuring float height, be sure to remove the gasket.*

### REASSEMBLY AND REMOUNTING

Reassemble and remount the carburetor in the reverse order of removal and disassembly, and also carry out the following steps:

- Apply small quantity of **THREAD LOCK SUPER "1303"** to the new screws and tighten them.

#### CAUTION:

**When installing the valves, face the punched mark on the valve to the outside.**

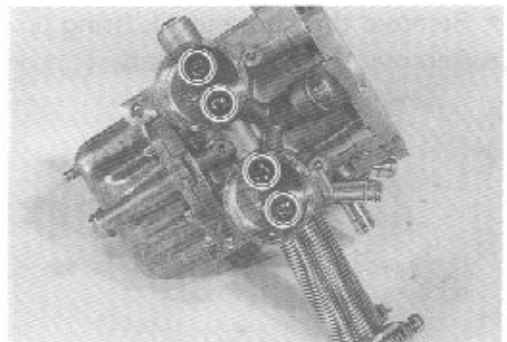
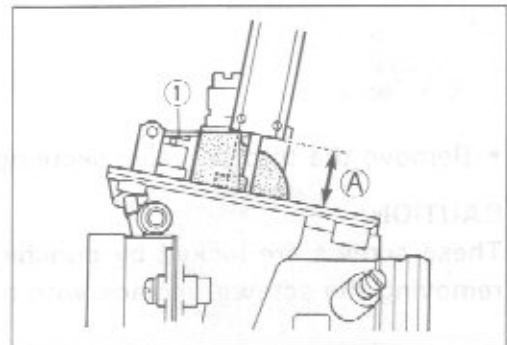
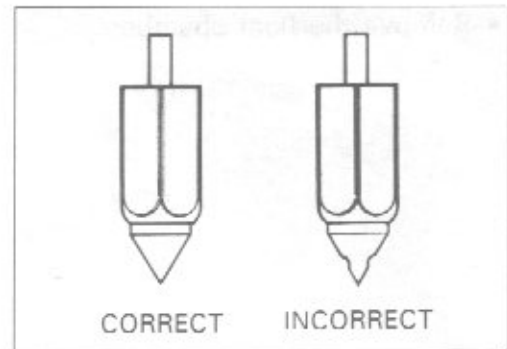

- When installing the diaphragm, align the tongue (1) of the diaphragm with the groove of carburetor body.

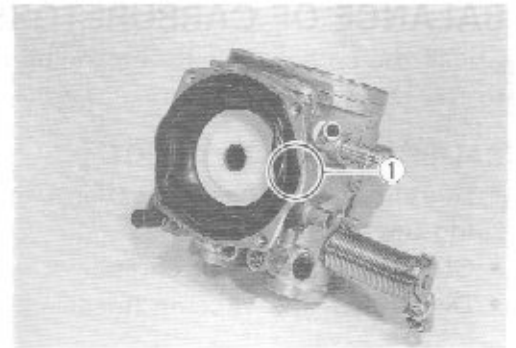

- Set each throttle valve in such a way that its top end (2) meets the foremost by-pass (3). This is accomplished by turning the throttle stop screw and balance screws.

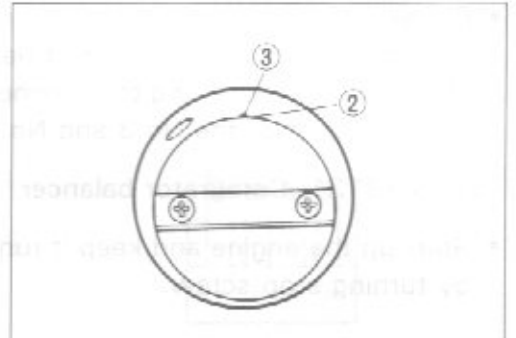

- After remounting the carburetors, the following adjustments are necessary.

- \* Throttle cable play ..... Refer to page 2-10.
- \* Engine idle r/min ..... Refer to page 2-10.
- \* Balancing carburetors ..... Refer to page 4-11.



## BALANCE OF CARBURETORS

Check the carburetors for balancing movement according to the following procedures.

### CALIBRATING EACH GAUGE

- Start up the engine and run it in idling condition for warming up.
- Stop the warmed-up engine.
- Disconnect the vacuum hoses.

- Connect the No.1 hose of balancer gauge to inlet of the No.1 cylinder and No.2 hose of balancer gauge to inlet of the No.2 cylinder, and then connect the No.3 and No.4 hoses to inlet of the No.3 and No.4 cylinders.

### 09913-13121: Carburetor balancer

- Start up the engine and keep it running at 2 000 r/min. by turning stop screw.
- Turn the air screw ① of the gauge so that the vacuum acting on the tube of that hose will bring the steel ball ② in the tube to the center line ③.
- After making sure that the steel ball stays steady at the center line, disconnect the No.1 and No.2 hoses of gauge from inlets and connect the No.2 hose to the inlet of No.1 cylinder and No.1 hose of gauge to inlet of No.2 cylinder.
- Turn the air screw ④ to bring the steel ball ⑤ to the center line.
- Repeat the above process on the No.3 and No.4 hoses. The balancer gauge is now ready for use in balancing the carburetors.

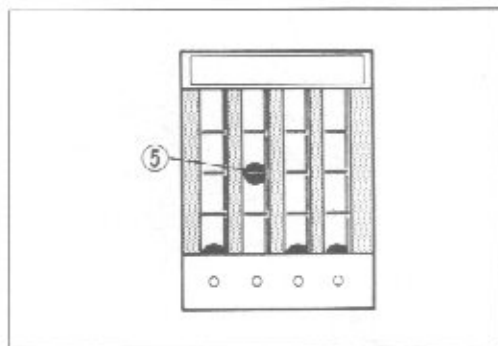
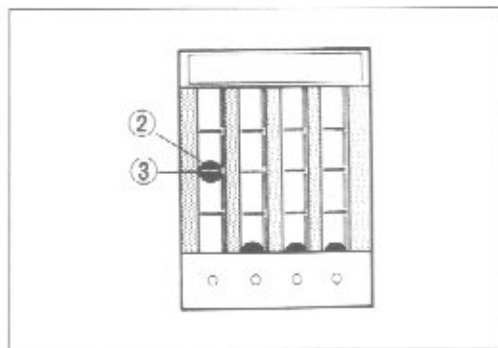
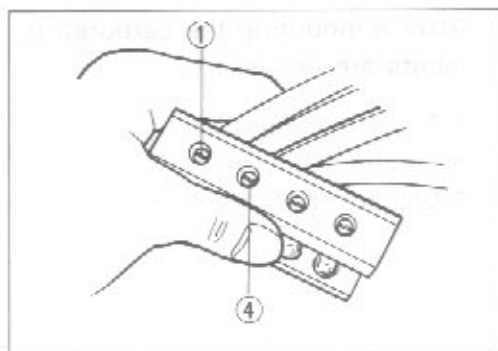
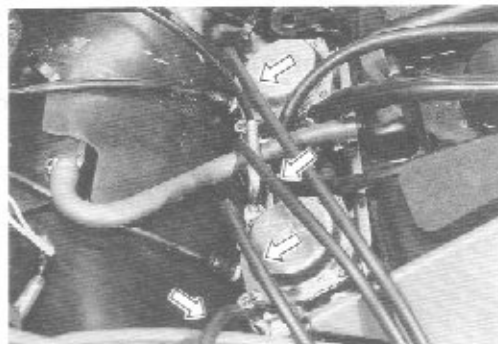
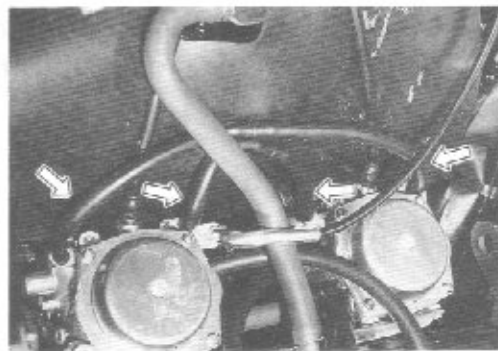

### BALANCING CARBURETORS

For balancing all the carburetor movement, connect the balancer gauge hoses to these vacuum inlets and adjust the balance of carburetors as follows:

- Start up the engine, and keep it running at 2 000 r/min. to see engine tachometer reading.  
A correctly adjusted carburetor has the steel balls in the No.1 through No.4 tubes at the same level.

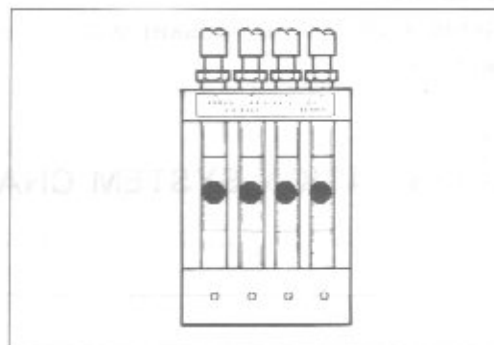
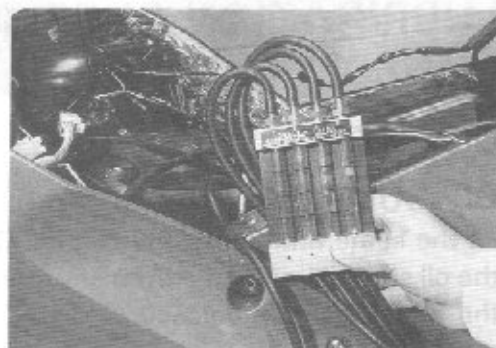

- If the steel balls are not in correct positions, adjust the throttle valve balance screws correctly.

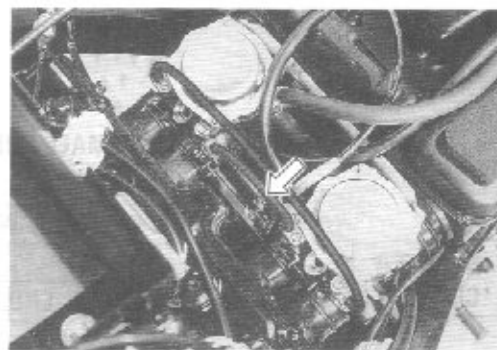

- After balancing the carburetors, set its speed between 1 500 and 1 700 r/min. by turning the throttle stop screw referring engine tachometer reading.

Idle r/min: 1 600  $\pm$  100 r/min.



# LUBRICATION SYSTEM

**OIL PRESSURE** ..... Refer to page 3-2.

**OIL FILTER** ..... Refer to page 2-9.

## OIL SUMP FILTER

At the same time wash the oil pan. Check to be sure that the oil sump filter is free from any sign of rupture and wash the filter clean periodically.

### CAUTION:

Replace the oil pan gasket with a new one to prevent oil leakage.

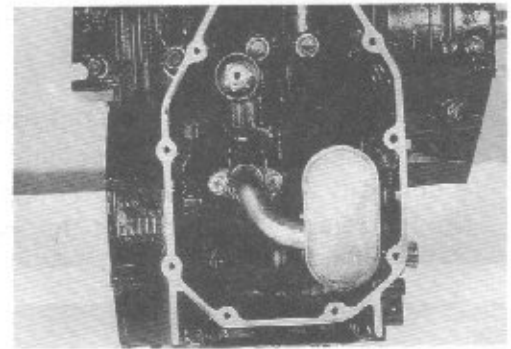

## LUBRICATION SYSTEM CHART

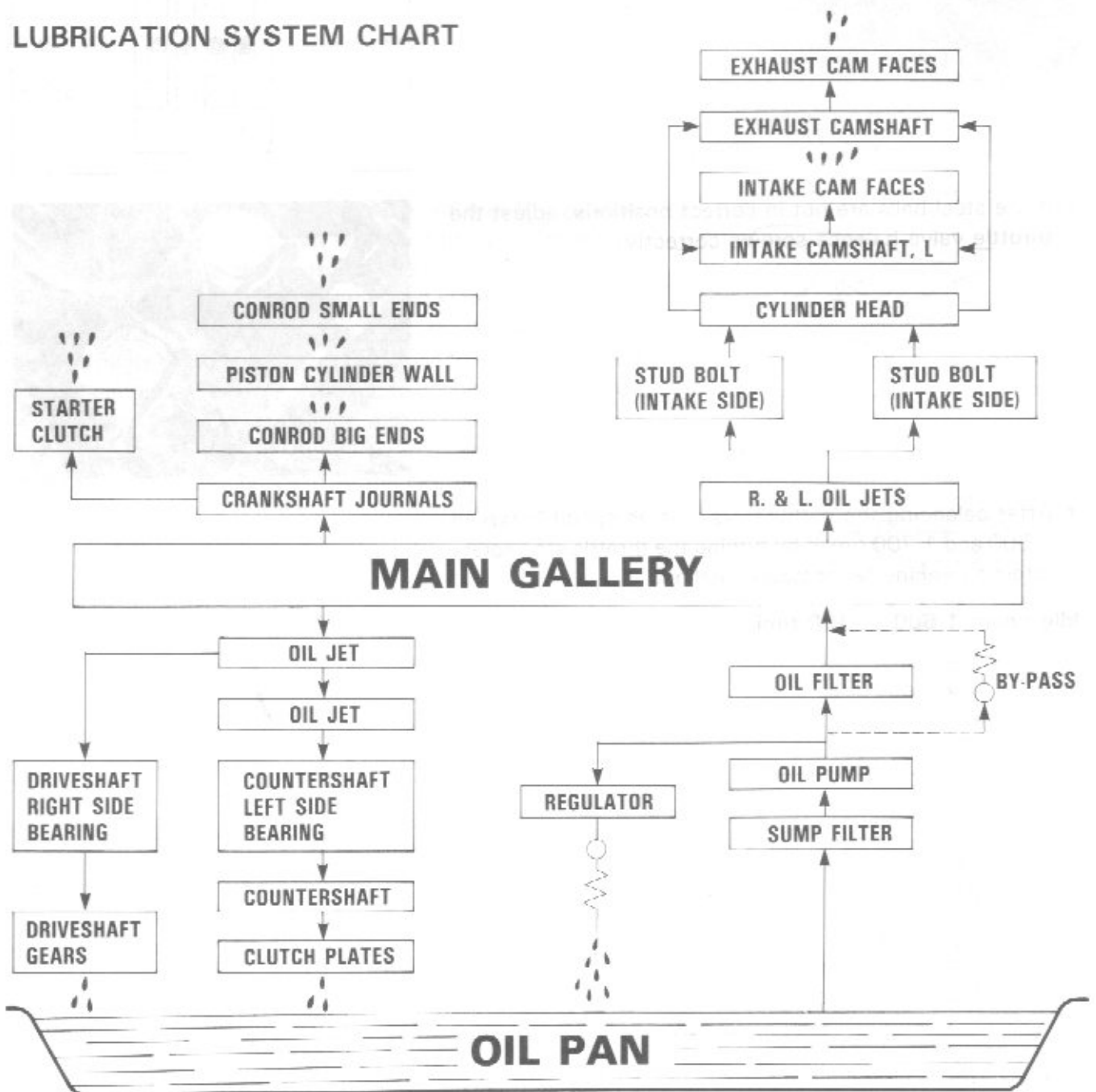

# COOLING SYSTEM

## CONTENTS

<b>COOLING SYSTEM</b> .....	<b>5-1</b>
<b>COOLING SOLUTION</b> .....	<b>5-2</b>
<b>RADIATOR AND RESERVOIR TANK</b> .....	<b>5-2</b>
<b>THERMOSTAT, WATER THERMO-GAUGE AND COOLING FAN SWITCH</b> .....	<b>5-5</b>
<b>WATER PUMP</b> .....	<b>5-9</b>

## COOLING SYSTEM

### DESCRIPTION

The engine is cooled by coolant set in forced recirculation through jackets formed in the cylinder and cylinder head, and through the radiator. For the water pump, a high-capacity centrifugal pump is used. The radiator is a tube-and-in type made of aluminum material, which is characterized by lightness in weight and good heat dissipation.

The thermostat is of wax pellet type, complete with a valve as the means of temperature-dependent control over the flow of coolant through the radiator. The valve is actuated by the temperature-sensitive wax contained in the pellet.

Referring to the following illustration, the thermostat is in the closed condition, so that coolant recirculates through the route comprising pump, engine, by-pass hole of the thermostat and radiator in the regulated condition.

As the coolant temperature rises to  $76.5^{\circ}\text{C}$  and the thermostat valve unseats, the normal coolant flow is established. At about  $90^{\circ}\text{C}$  of coolant temperature, the thermostat becomes completely open and most of heat is released to the atmosphere through the radiator core.

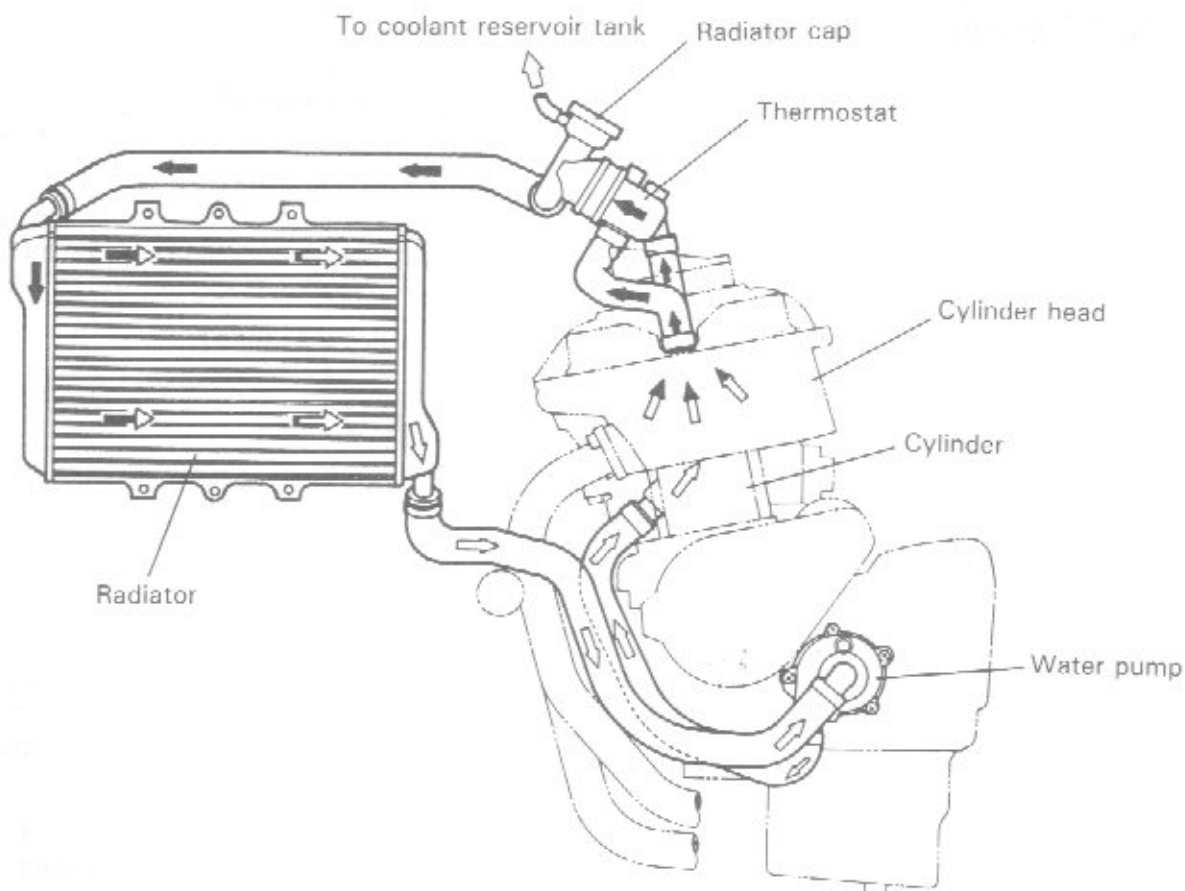

## COOLING SOLUTION

At the time of manufacture, the cooling system is filled with a 50 : 50 solution of distilled water and anti-freeze/summer coolant. This 50 : 50 mixture will provide excellent heat protection, and will protect the cooling system from freezing at temperatures above  $-31^{\circ}\text{C}$  ( $-24^{\circ}\text{F}$ ).

If the motorcycle is to be exposed to temperatures below  $-31^{\circ}\text{C}$  ( $-24^{\circ}\text{F}$ ), this mixing ratio should be increased up to 55% or 60% according to the Fig. 2.

**NOTE:**

*The characteristics of different anti-freezes vary. Read the label to know the protection you will have.*

**CAUTION:**

Do not put in more than 60% anti-freeze or less than 50%.  
Do not mix different brands of anti-freeze.

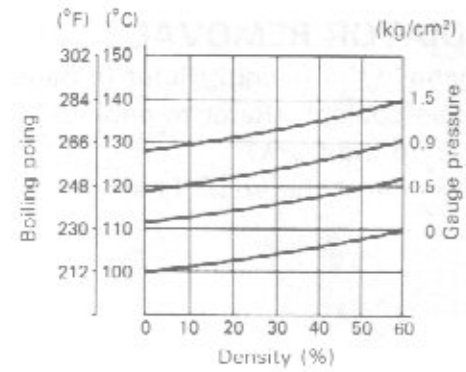

Fig. 1 Coolant density-boiling point curve

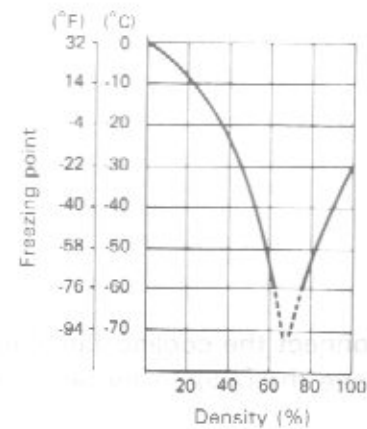
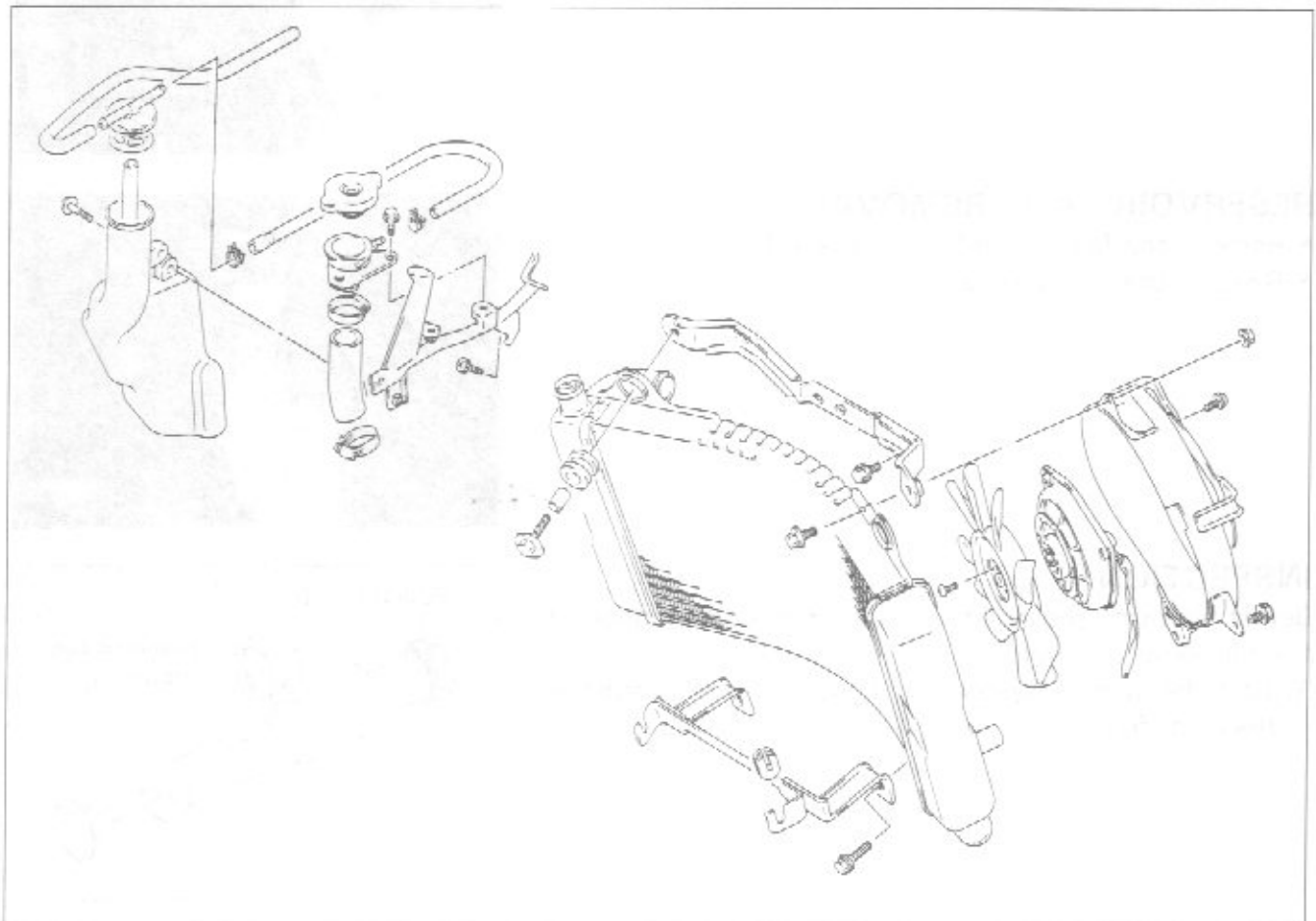

Fig. 2 Coolant density freezing point curve

## RADIATOR AND RESERVOIR TANK



## RADIATOR REMOVAL

- Remove the fairing. (Refer to page 7-1.)
- Drain coolant. (Refer to page 2-11.)
- Pull up the trunk.
- Disconnect the water hoses by loosening the clamps.

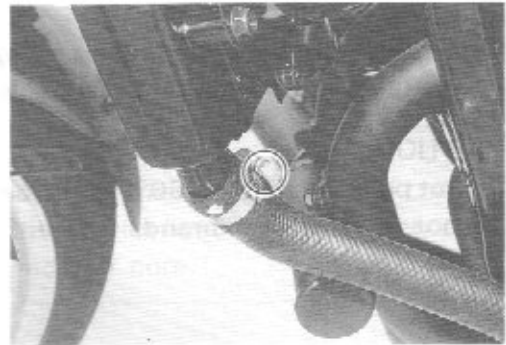
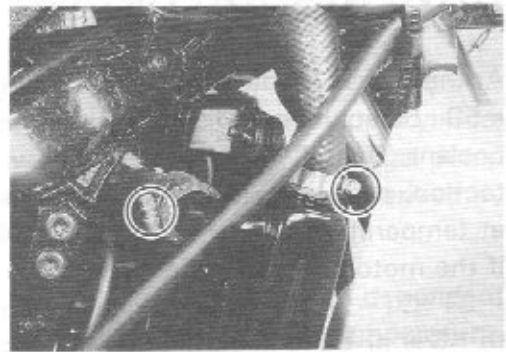

- Disconnect the cooling fan lead wires.
- Remove the radiator by removing the mounting bolts.

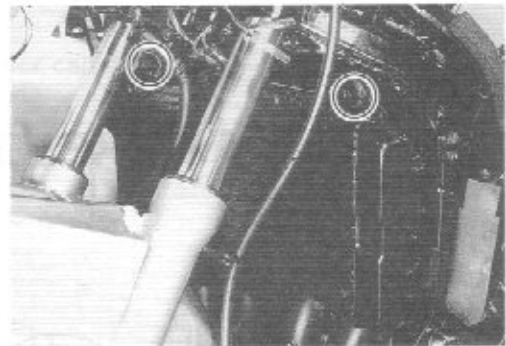

## RESERVOIR TANK REMOVAL

- Remove the fairing. (Refer to page 7-1.)
- Remove the reservoir tank.

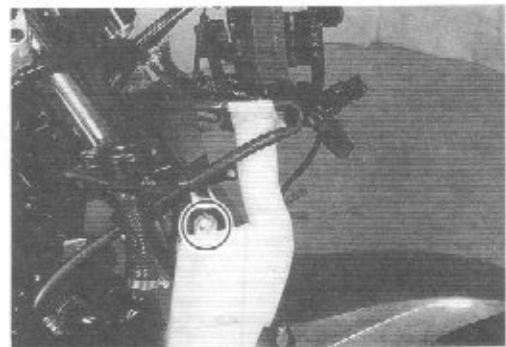

## INSPECTION

Before removing the radiator and draining coolant, inspect the following two items.

1. Test the cooling system for tightness with a radiator tester as follows:

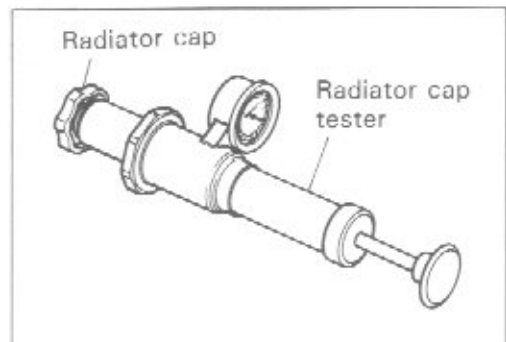

Remove the radiator cap, and connect the tester to the filter. Give a pressure of about  $1 \text{ kg/cm}^2$  ( $14.2 \text{ psi}$ ) and see if the system holds this pressure for 10 seconds. If the pressure should fall during this 10-second interval, it means that there is a leaking point in the system; In such a case, inspect the entire system and replace the leaking component or part.

2. Test the radiator cap for relieving pressure by using the radiator tester in the following manner: Fit the cap to the tester, as shown, and build up pressure slowly by operating the tester. Make sure that the pressure build-up stops at  $1.1 \pm 0.15 \text{ kg/cm}^2$  and that, with the tester held at a standstill, the cap is capable of that pressure for at least 10 seconds. Replace the cap if it is found not to satisfy either of these two requirements.

#### Radiator cap valve release pressure:

$110 \pm 15 \text{ kPa}$  ( $1.1 \pm 0.15 \text{ kg/cm}^2$ ,  $15.6 \pm 2.1 \text{ psi}$ )

3. Road dirt or trashes stuck to the fins must be removed. Use of compressed air is recommended for this cleaning. Fins bent down or dented can be repaired by straightening them with the blade of a small screwdriver.
4. Any water hose found in cracked condition or flattened must be replaced.

#### RADIATOR HOSE

Inspect for leakage from the radiator hose connecting (joint) section and from the radiator hose itself and fork kinks in the radiator hose.

If any leakage from the radiator hose are detected, the radiator hose should be replaced.

Any leakages from the connecting (joint) section should be corrected by proper tightening.

#### INSTALLATION

The radiator is to be installed in the reverse order of the removal procedure and refer to page 5-2. After installing the radiator, be sure to add coolant; refer to page 2-11 for refilling information.

#### COOLING FAN INSPECTION

Test the cooling fan drive motor for load current with an ammeter connected as shown in the illustration.

The voltmeter is for making sure that the battery applies 12 volts to the motor. With the motor with electric motor fan running at full speed, the ammeter should be indicating not more than 5 amperes.

If the fan motor does not turn, replace the motor assembly with a new one.

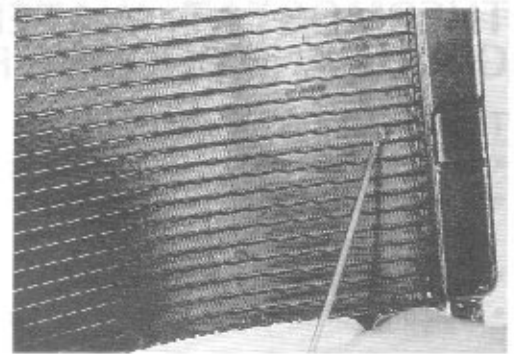

Remove the dirt from the radiator fins.

Test the radiator cap.

Remove the radiator cap.

Remove the radiator cap.

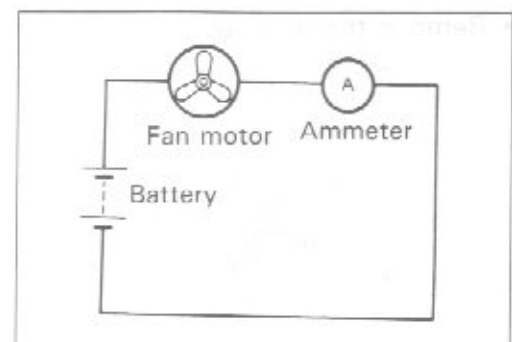

## THERMOSTAT, WATER THERMO-GAUGE AND COOLING FAN SWITCH

### THERMOSTAT REMOVAL

- Remove the radiator. (Refer to page 5-3.)
- Remove the battery and battery holder. (Refer to pages 3-4 and 3-5.)
- Remove the rubber cover. (Refer to page 3-5.)
- Disconnect the water hoses by loosening the clamp.
- Disconnect the thermo-gauge and fan switch lead wires.

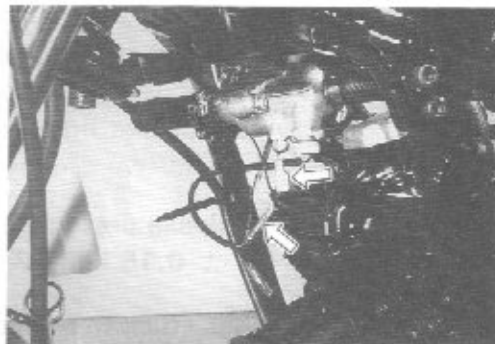
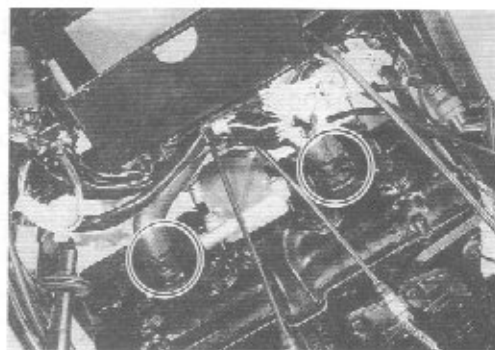

- Remove the thermostat case by removing the mounting bolts.

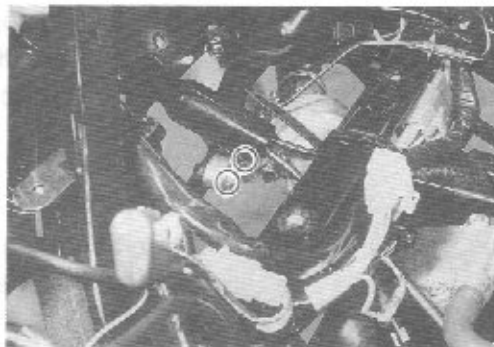

- Separate the thermostat case.

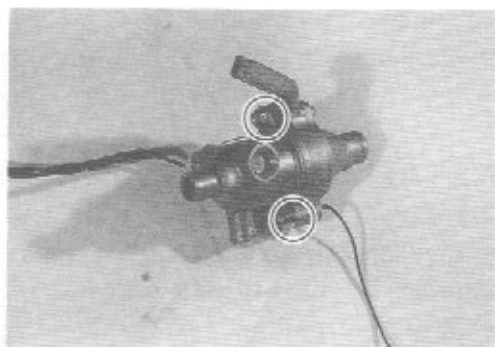

- Remove the thermostat.

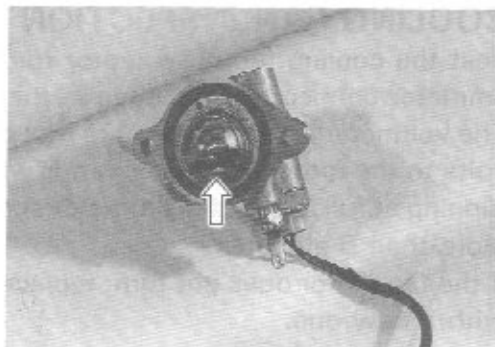

## THERMOSTAT INSPECTION

Inspect the thermostat pellet for signs of cracking.

Test the thermostat at the bench for control action, in the following manner.

- Pass a string between flange, as shown in the illustration.
- Immerse the thermostat in the water contained in the pan, as shown in the illustration. Note that the immersed thermostat is in suspension. Heat the water by placing the pan on a stove and observe the rising temperature on the thermometer.
- Read the thermometer just when the thermostat drops to the bottom of the pan. This reading, which is the temperature level at which the thermostat valve begins to open, should be anywhere between 74.5°C and 78.5°C.

**Thermostat valve opening temperature:**  
74.5–78.5°C (116–173°F)

- Keep on heating the water to raise its temperature to and beyond 90°C (194°F).
- Just when the water reaches 90°C, the thermostat valve should have lifted by at least 7 mm.

**Thermostat valve lift: Over 7 mm (0.28 in)**  
at 90°C (194°F)

- A thermostat failing to satisfy either of the two requirements (start-to-open temperature and valve lift) must be replaced.

## THERMOSTAT REASSEMBLY

- The air bleeder hole (A) of the thermostat faces upside.

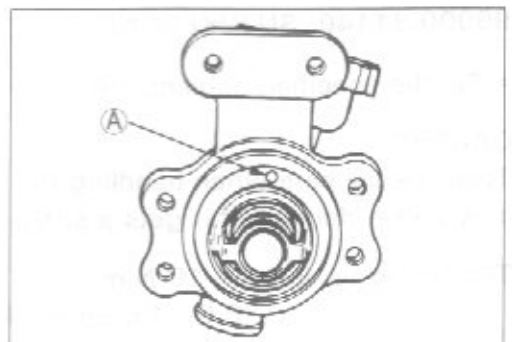
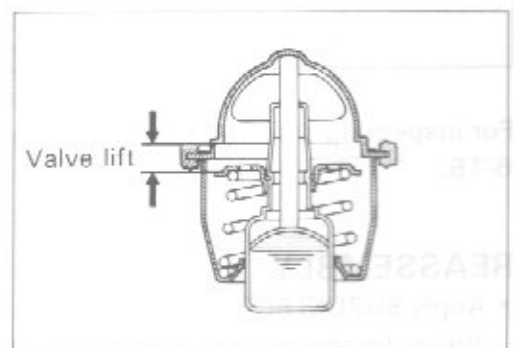
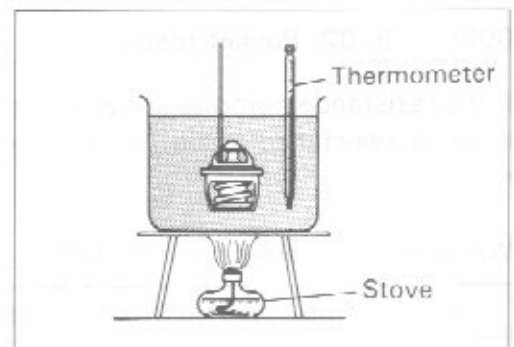
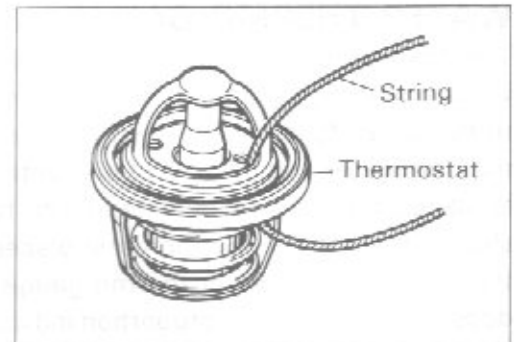



## WATER THERMO-GAUGE AND COOLING FAN SWITCH REMOVAL

- Remove the thermo-gauge ① and cooling fan switch ②.

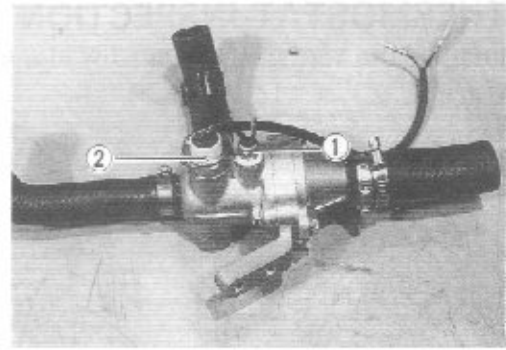

## WATER THERMO-GAUGE INSPECTION

Test the water thermo-gauge at the bench to see if its ohmic value changes, as specified, with temperature. The test is to be run as follows: Connect the water thermo-gauge to the ohmmeter and place it in oil contained in a pan, which is placed on a stove, heat the oil to raise its temperature slowly, reading the thermometer placed in the pan and also the ohmmeter. A water thermo-gauge whose ohmic value does not change in the proportion indicated in the table must be replaced.

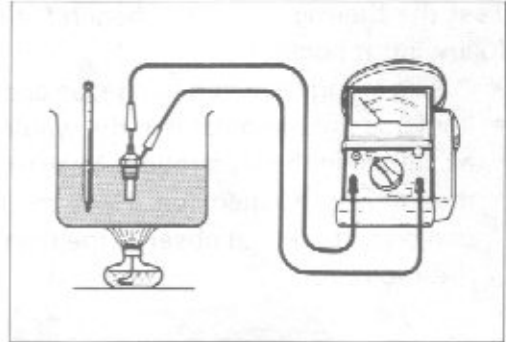

### 09900-25002: Pocket tester

If the resistance noted to show infinity or too much difference in resistance value, water thermo-gauge must be replaced.

### Water thermo-gauge specification

Water temp. °C (°F)	Standard resistance (Ω)
50 (122)	Approx. 167
120 (248)	Approx. 17

For inspecting the water temperature meter, refer to page 6-15.

## REASSEMBLY

- Apply SUZUKI BOND NO. 1207B to the thread portion of the water thermo-gauge and install it to the cylinder head.

### 99000-31140: SUZUKI BOND NO.1207B

- Fill the specified coolant. (Refer to page 2 11.)

### CAUTION:

Take special care when handling the water thermo-gauge may cause damage if it gets a sharp impact.

Tightening torque: 6–10 N·m  
(0.6–1.0 kg·m, 4.5–7.0 lb-ft)

## COOLING FAN SWITCH INSPECTION

- The cooling fan switch must be checked for its temperature-initiated closing action at the specification value of 105°C (221°F) by testing it at the bench as shown in the figure. Connect the switch to a circuit tester and raise the temperature of the oil in the pan, and read the temperature when the switch closes.

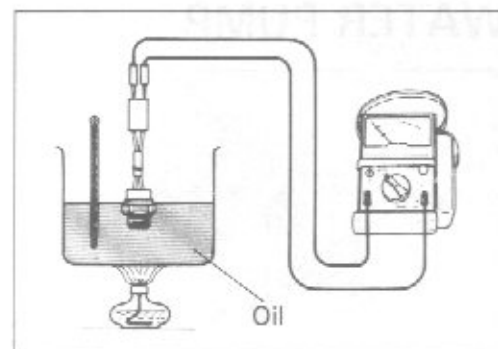

09900-25002: Pocket tester

### Thermo-switch specification

OFF → ON	Approx. 105°C (221°F)
ON → OFF	Approx. 100°C (212°F)

## REASSEMBLY

### NOTE:

Do not forget the new O-ring.

Tightening torque: 9.0–14 N·m  
(0.9–1.4 kg·m, 6.5–10.0 lb-ft)

### CAUTION:

Take special care when handling the cooling fan switch. It may cause damage if cooling fan switch gets a sharp impact. Replace the O-ring with a new one.

# WATER PUMP

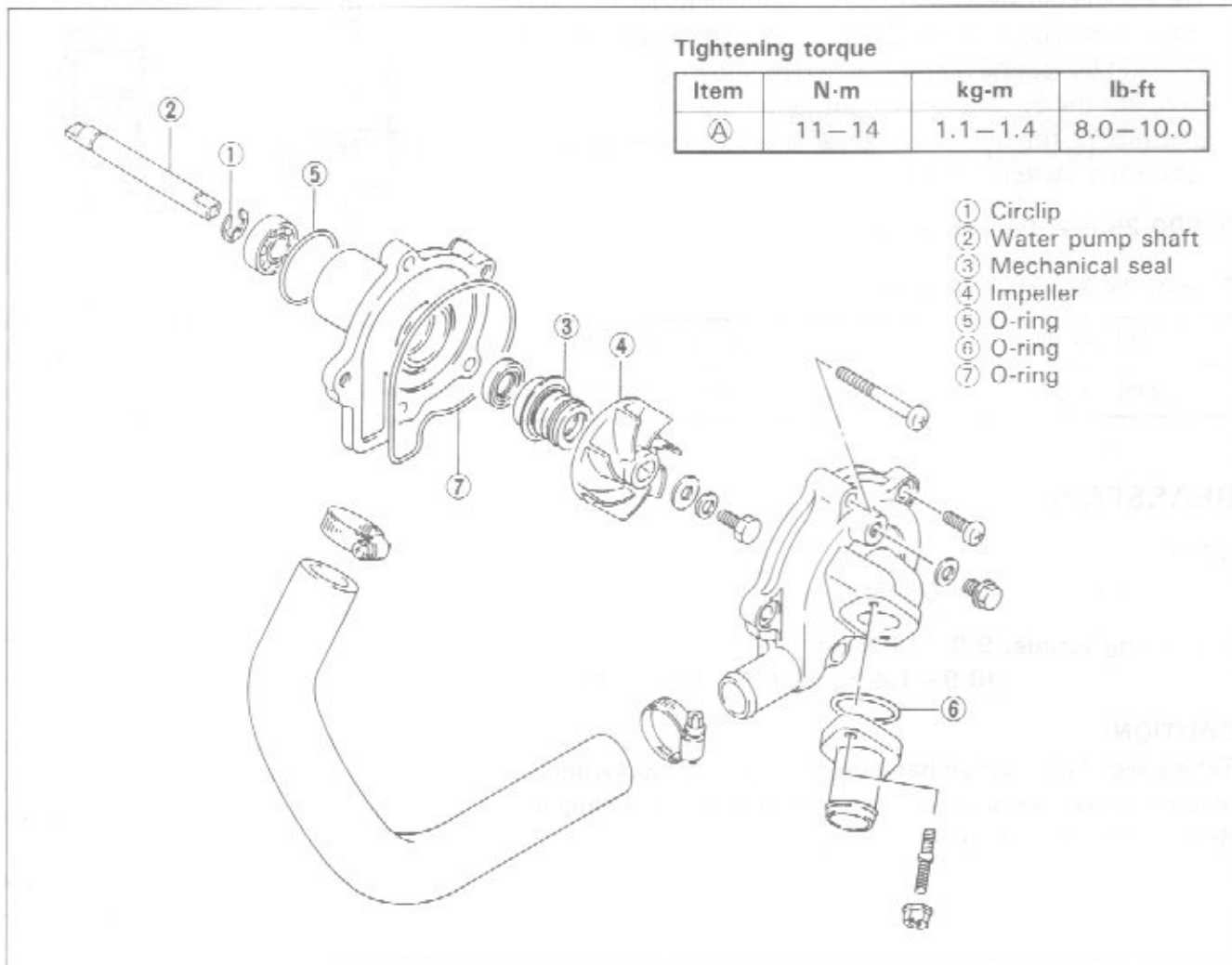

## REMOVAL AND DISASSEMBLY

- Remove the lower fairing. (Refer to page 7-1.)
- Drain engine oil. (Refer to page 2-8.)
- Drain coolant. (Refer to page 2-11.)
- Disconnect the water hose from the water pump.
- Remove the water pump assembly by removing the mounting bolts.
- Remove the water pump cover.

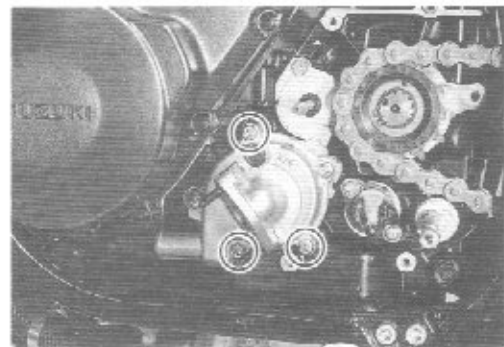

- Remove the impeller with a water pump plier.

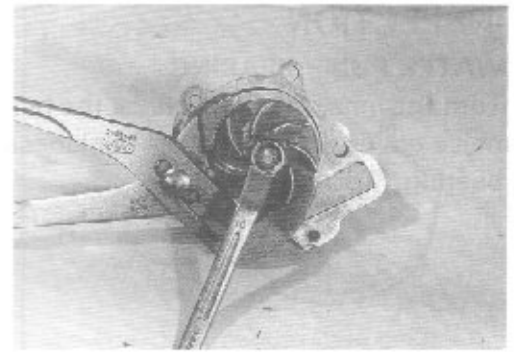

- Remove the mechanical seal ring and gasket.

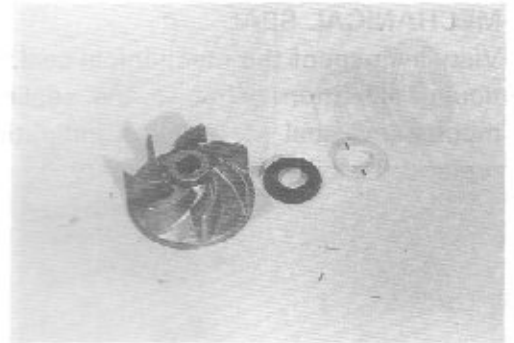

- Remove the water pump shaft by removing the circlip.
- Remove the mechanical seal.

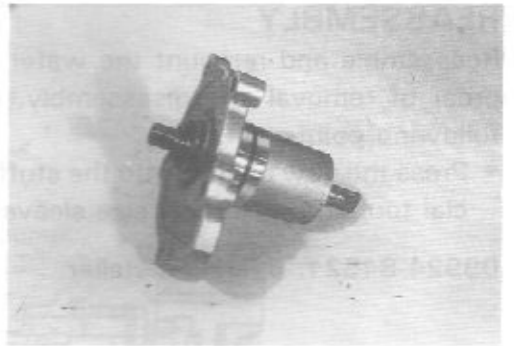

- Remove the oil seal ①.

**CAUTION:**

The removed mechanical seal or oil seal should be replaced with a new one.

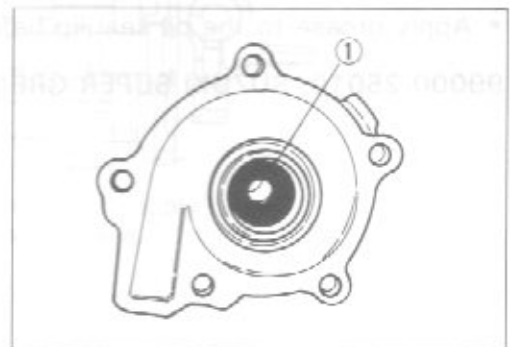

- Drive out the bearing using a suitable bar.

**CAUTION:**

The removed bearing should be replaced with a new one.

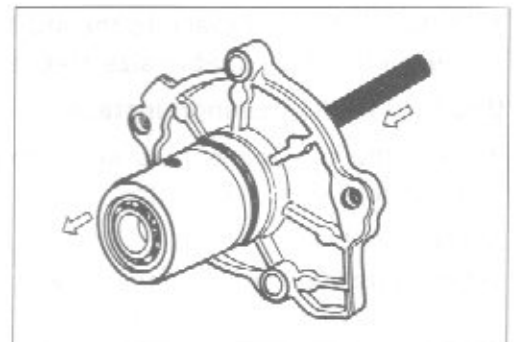

## INSPECTION

### WATER PUMP BEARING

Turn the inner race and check the bearing play. If abnormal noise occurs or any sign of stickiness is noted, replace the bearing with a new one.

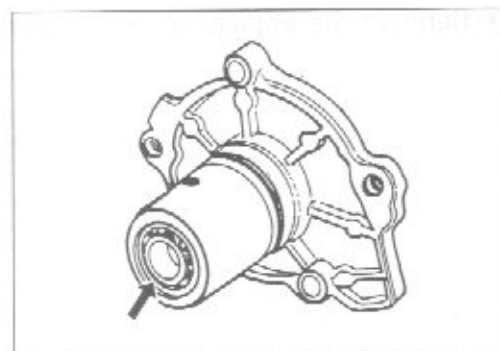

### MECHANICAL SEAL

Visually inspect the mechanical seal for damage, with particular attention given to the sealing face. Replace the mechanical seal that shows indications of leakage. Also replace the oil seal if necessary.

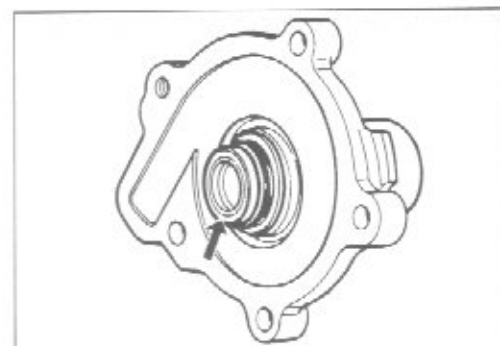

## REASSEMBLY

Reassemble and remount the water pump in the reverse order of removal and disassembly. Pay attention to the following points:

- Press the new bearing into the stuffing box with the special tool and a suitable size sleeve etc.

**09924-84521: Bearing installer**

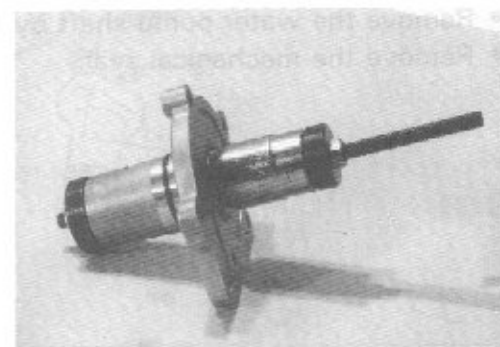

- Apply grease to the oil seal lip before installing.

**99000-25010: SUZUKI SUPER GREASE "A"**

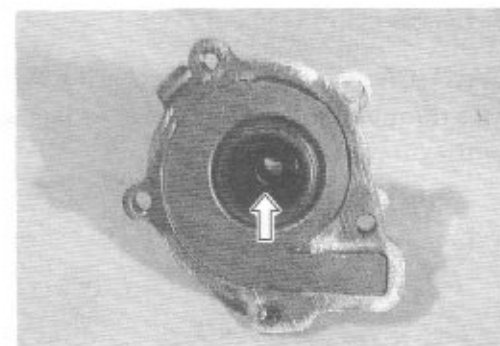

- Press the new oil seal into the stuffing box with the special tool and a suitable size sleeve etc.

**09924-84521: Bearing installer**

- Press the new mechanical seal into the stuffing box with a suitable size sleeve etc.

#### NOTE:

When installing the mechanical seal, apply **SUZUKI BOND NO.1207B** to its outer surface.

**99000-31140: SUZUKI BOND NO.1207B**

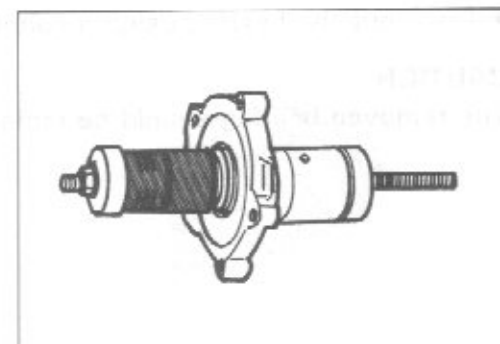

- Replace the O-ring and water seal with new ones when reassembling the water pump.

**NOTE:**

The mechanical seal ring must be assembled with marked face ① of the ring toward the impeller.

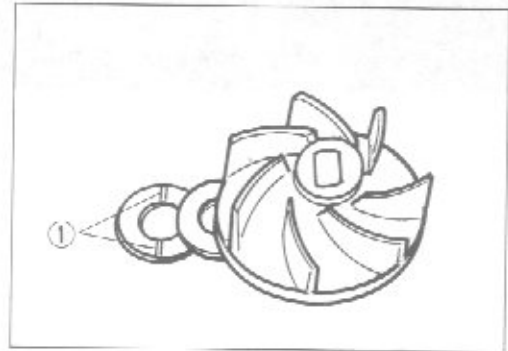

- Tighten the impeller securing bolt to the specified torque.

**Tightening torque: 7–9 N·m**

**(0.7–0.9 kg·m, 5.0–6.5 lb·ft)**

**NOTE:**

The seal lip side ② faces impeller.

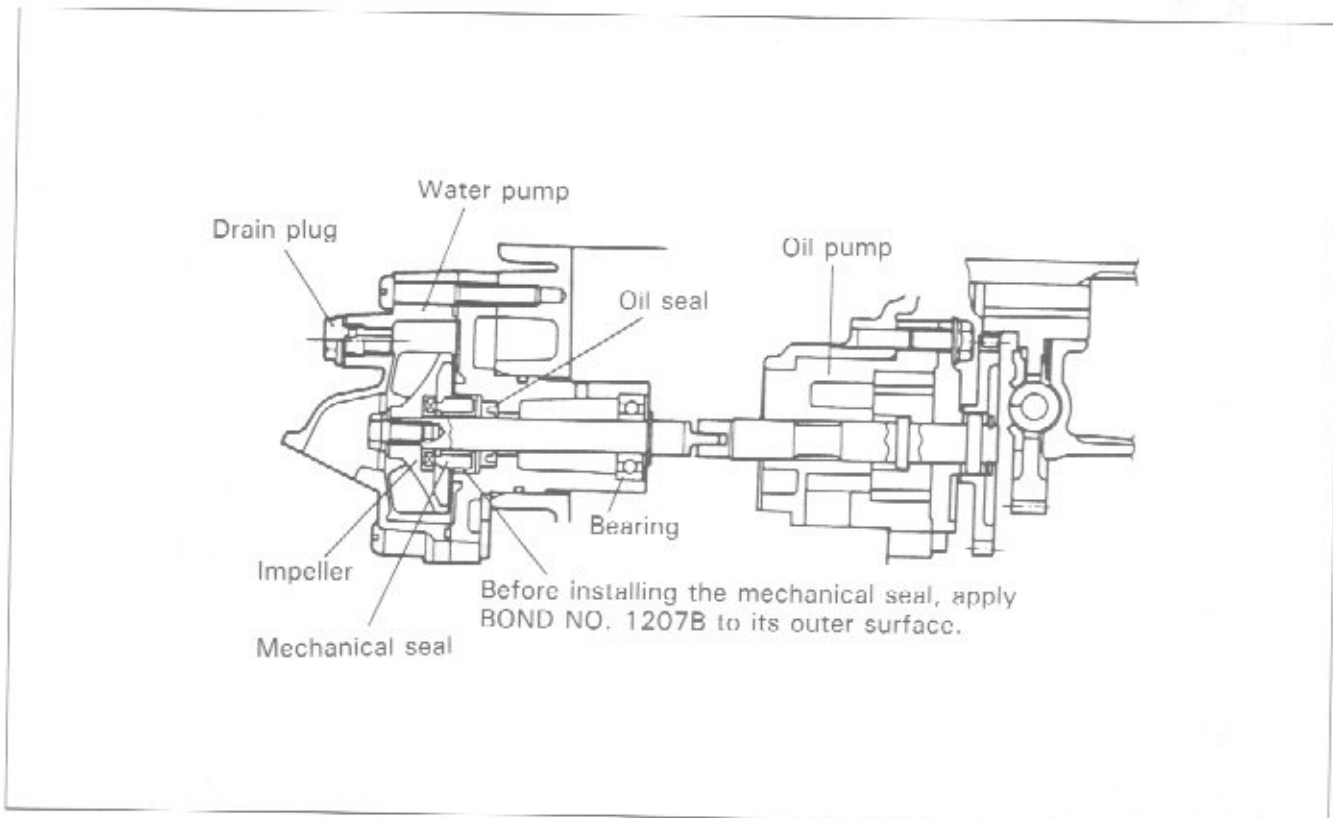
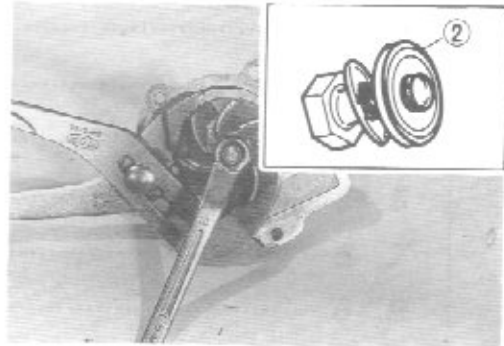

Refer to page 8-13 for the radiator hose routing.

# ELECTRICAL SYSTEM

## CONTENTS

<b>IGNITION SYSTEM</b> .....	6- 1
<b>DESCRIPTION</b> .....	6- 1
<b>INSPECTION</b> .....	6- 1
<b>CHARGING SYSTEM</b> .....	6- 5
<b>DESCRIPTION</b> .....	6- 5
<b>INSPECTION</b> .....	6- 7
<b>STARTER SYSTEM</b> .....	6- 9
<b>DESCRIPTION</b> .....	6- 9
<b>REMOVAL AND DISASSEMBLY</b> .....	6- 9
<b>INSPECTION</b> .....	6-10
<b>REASSEMBLY</b> .....	6-11
<b>STARTER RELAY INSPECTION</b> .....	6-12
<b>SIDE-STAND/IGNITION INTERLOCK SYSTEM</b> .....	6-12
<b>DESCRIPTION</b> .....	6-12
<b>INSPECTION</b> .....	6-14
<b>FRONT AND REAR SOLENOID AND CONTROL UNIT</b> .....	6-15
<b>INSPECTION</b> .....	6-15
<b>WATER TEMPERATURE METER</b> .....	6-15
<b>COMBINATION METER</b> .....	6-16
<b>LAMPS</b> .....	6-17
<b>SWITCHES</b> .....	6-18
<b>BATTERY</b> .....	6-20
<b>SPECIFICATIONS</b> .....	6-20
<b>INITIAL CHARGING</b> .....	6-20
<b>SERVICING</b> .....	6-21
<b>RECHARGING OPERATION</b> .....	6-22

# IGNITION SYSTEM

## DESCRIPTION

The fully transistorized ignition system consists of a signal generator, ignitor unit, ignition coils and spark plugs. The characteristic of the ignition timing is programmed and stored in the computer of the ignitor unit. The signal generator comprises the rotor tips and pickup coil.

The signal generator is mounted at the right side crankshaft. The induced signal in the signal generator is sent to computer of the ignitor and calculates the best ignition timing. The outputs signal to the transistor of the I.G. coil output circuit which is connected to the primary windings of the ignition coil which is turned OFF and ON accordingly, thus it induces the secondary current on the ignition coil secondary windings and produce the spark between spark plug gaps.

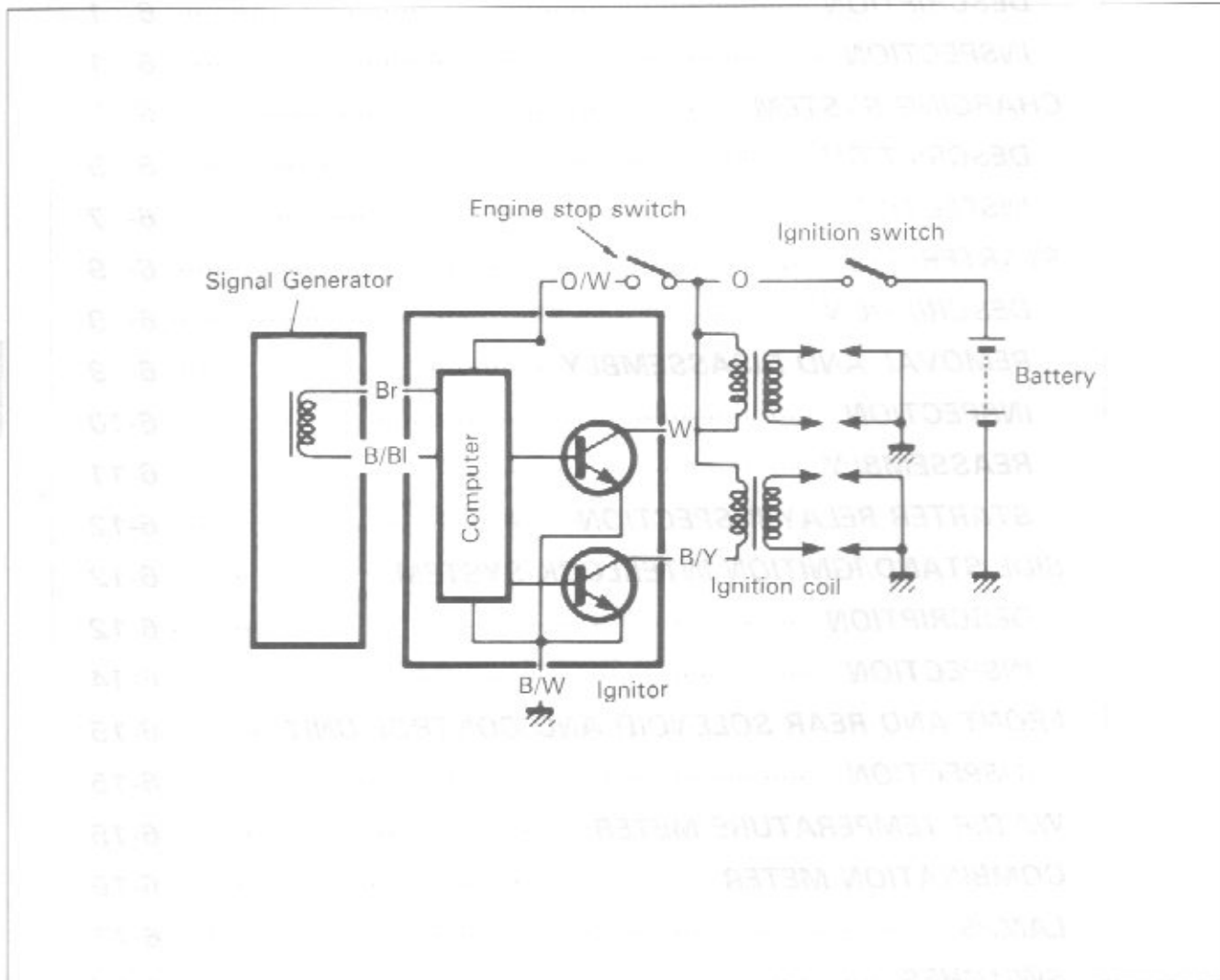

## INSPECTION

### SIGNAL GENERATOR (Checking with Pocket Tester)

- Remove the seat and right frame cover.
- Disconnect the signal generator lead wire coupler.
- Measure the resistance between lead wires. If the resistance is infinity or less than the specifications, the signal generator must be replaced.

Signal coil resistance: Approx. 400  $\Omega$

09900-25002: Pocket tester

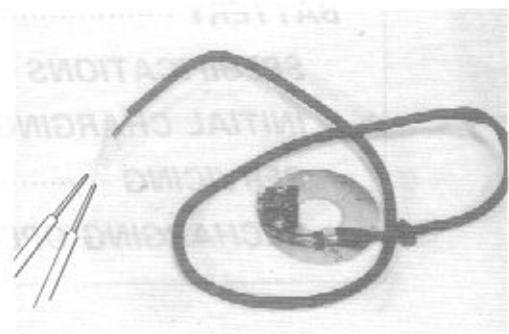



**IGNITION COIL (Checking with Electro Tester)**

- Remove the seat, and lift the front end of trunk.
- Remove the battery and battery holder.
- Remove the ignition coils, left and right.

**NOTE:**

Make sure that the three-needle sparking distance of electro tester is set at 8 mm (0.3 in).

- With the tester and jumper wire, test the ignition coil for sparking performance in accordance with the following two steps.

STEP ①: Connect the jumper wire to the spark plug cap and ignition coil ground.

STEP ②: Switch over the jumper wire to the other plug cap and ground.

If no sparking or orange color sparking occurs in the above conditions, it may be caused by defective coil.

**Spark performance: Over 8 mm (0.3 in)**

**09900-28106: Electro tester**

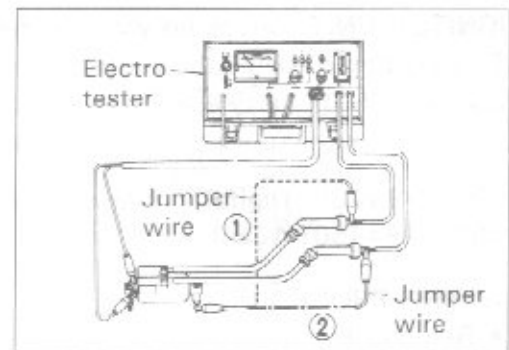
**IGNITION COIL (Checking with Pocket Tester)**

- A SUZUKI pocket tester or an ohm meter may be used, instead of the electro tester. In either case, the ignition coil is to be checked for continuity in both primary and secondary windings. Exact ohmic readings are not necessary, but if the windings are in sound condition, their continuity will be noted with these approximate ohmic values.

**09900-25002: Pocket tester**

**Ignition coil resistance**

**Primary : 2.0–4.0  $\Omega$  (Terminal–Terminal)**

**Secondary: 36–56 k $\Omega$  (Plug cap–Plug cap)**

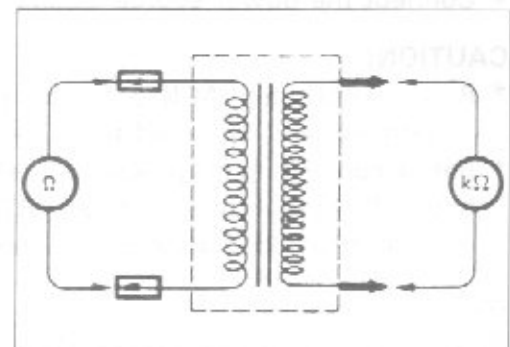
**SPARK PLUG**

- Clean the plug with a wire brush and pin. Use the pin to remove carbon, taking care not to damage the porcelain.
- Check the gap with a thickness gauge.

**Spark plug gap: 0.6–0.7 mm (0.024–0.028 in)**

	NGK	NIPPONDENSO
Hot type	CR6HSA	U20FSR-U
<b>Standard</b>	<b>CR7HSA</b>	<b>U22FSR-U</b>
Cold type	CR8HSA	U24FSR U

**NOTE:**

"R" type spark plug is installed for some specifications. "R" type spark plug has a resistor located at the center electrode to prevent radio noise.

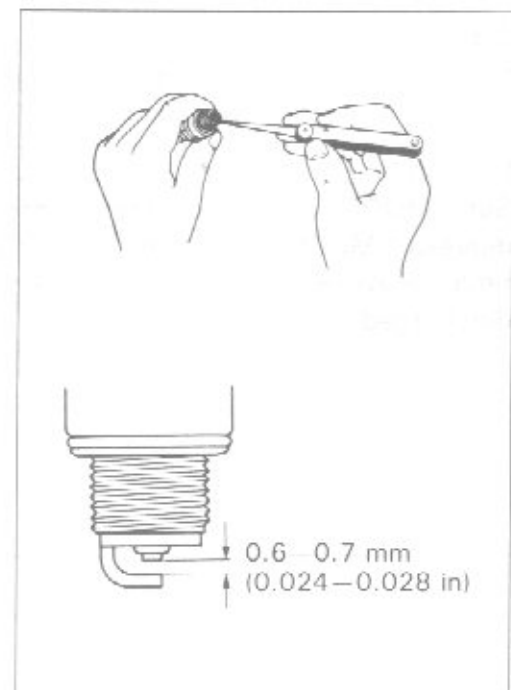

**IGNITOR UNIT (Checking with Digital Ignitor Checker)**

This section explains the checking procedure for the ignitor unit using Digital Ignitor Checker (special tool). With this checker, the ignitor unit can be checked either on the machine or off the machine. The following explains the checking procedure on the machine.

**09931-94430: Digital ignitor checker**

**09931-94460: Adaptor**

**WIRING PROCEDURE:**

- Remove the fairing.
- Disconnect two ignitor lead wire couplers ① at the ignitor unit.

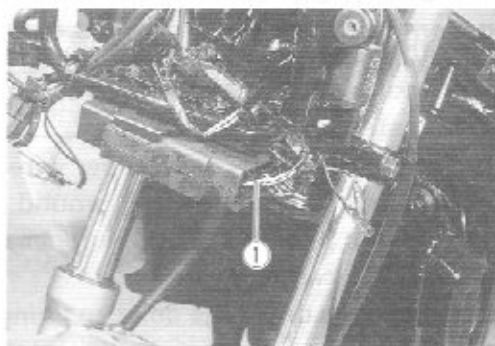

- Prepare the ignitor checker lead wire "MODE 2" ② and adaptor ③ which comes supplied with the ignitor checker and connect their ends to the ignitor unit and checker.
- Connect the power source leads ④ to the battery.

**CAUTION:**

- \* Be sure that the **BLACK** lead is connected to the battery  $\ominus$  terminal and **RED** lead to the ① terminal.
- \* Before connecting the power source leads, make sure that both "POWER" button and "START" switch are in "off" position (POWER button not depressed).

**NOTE:**

*Be sure that the battery used is in fully-charged condition.*

**CHECK PROCEDURE:**

With all the lead wires properly connected, check the ignitor unit in the following four steps.

**First Step:**

Set "MODE" switch on the adaptor "2" position and depress "MODE 2" button then "POWER" button. This time, "POWER" lamp should come on, if not, battery is undercharged.

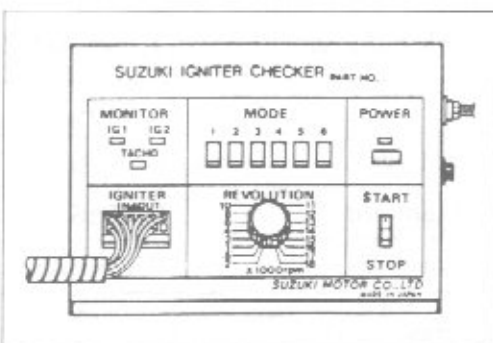
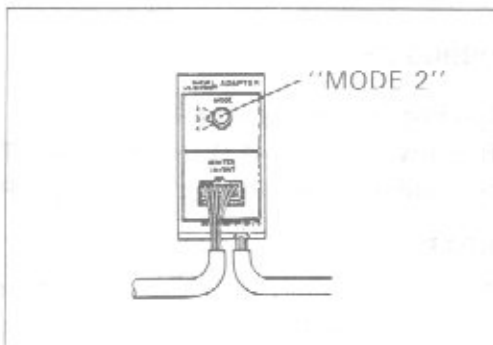
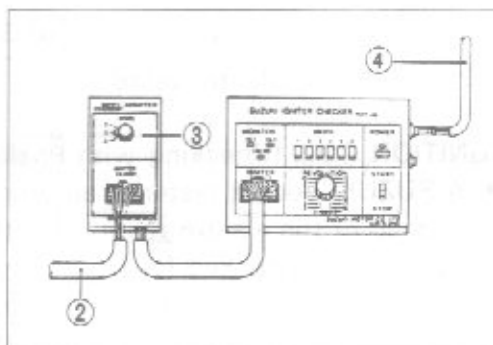

**Second Step:**

Set "REVOLUTION" dial pointer to "4" position in which the checker produces the ignition primary current pulses simulating 4 000 r/min of engine revolution when "START" switch is turned on. With "START" switch is turned to ON position, check that two "MONITOR" lamps (1) and (2) turn ON. Then, turn back "REVOLUTION" dial pointer to ".2" position and check that two "MONITOR" lamps (1) and (2) turn ON and OFF in slow frequency in order of (1)—(2) as illustrated.

If these lamps do not turn on and off, the ignitor unit should be replaced.

**Third Step:**

Turn "REVOLUTION" dial up gradually (assuming the engine is gradually revved up) and check that the MONITOR lamps flash frequency as explained in the second step above increases. As the dial pointer passes beyond the graduation "4" (4 000 r/min), the two lamps should shown continuously lighted.

**Fourth Step:**

Turn "START" switch to STOP position. If the "IG1" or "IG2", or both lamps remain light more than 5 seconds, the ignitor unit must be replaced.

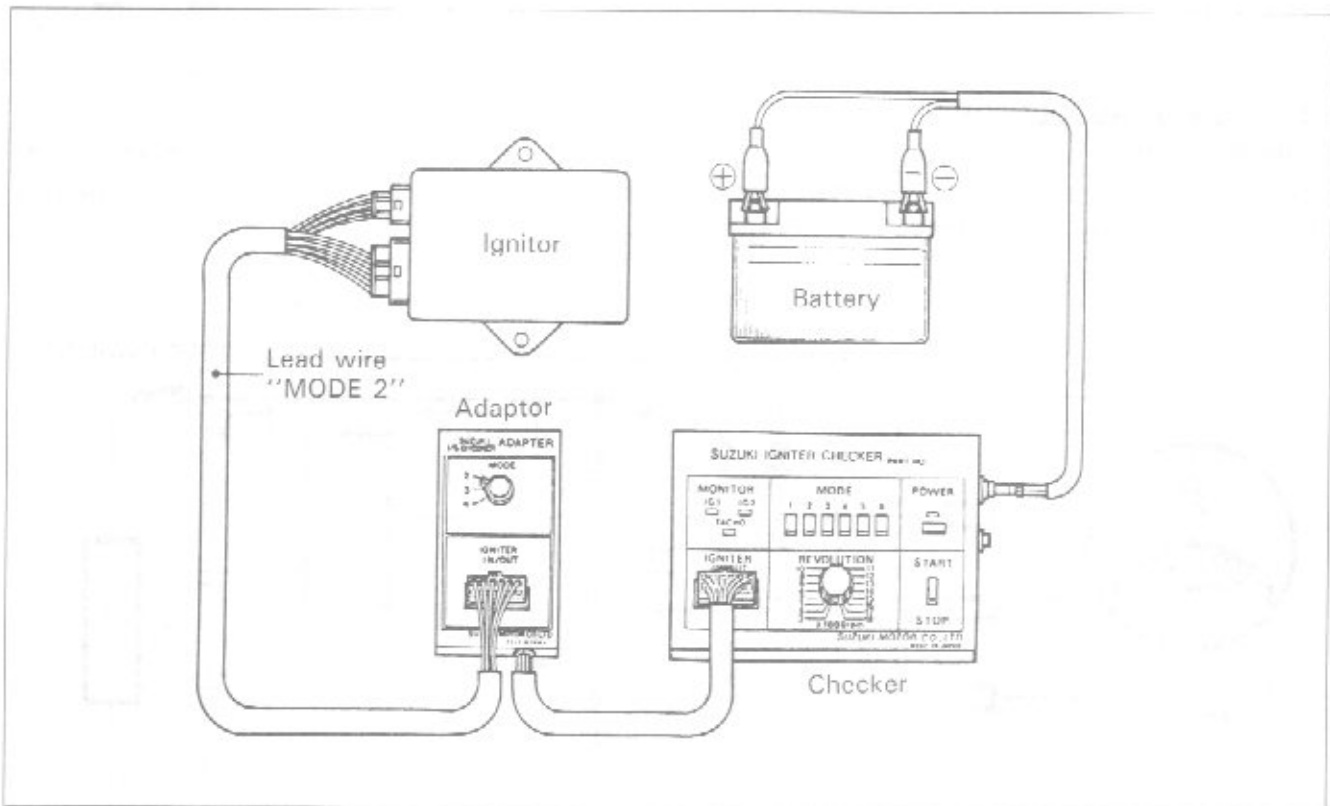
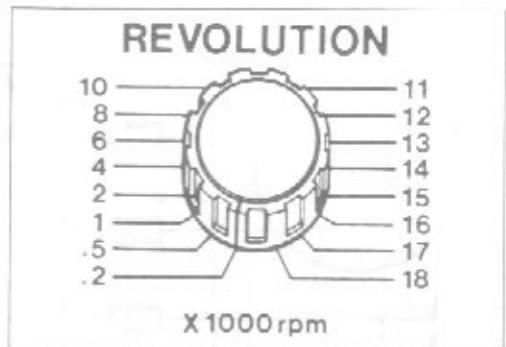
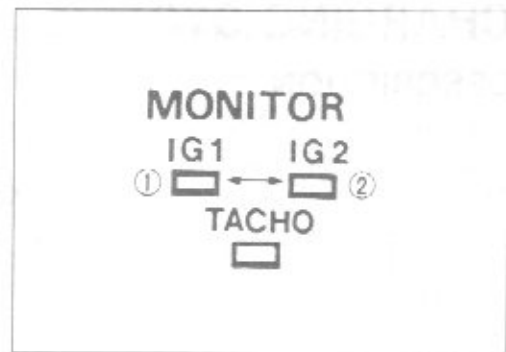

## CHARGING SYSTEM

### DESCRIPTION

The circuit of the charging system is indicated in the figure, which is composed of an AC generator, regulator/rectifier unit and battery.

The AC current generated from the AC generator is rectified by the rectifier and is turned into DC current, then it charges the battery.

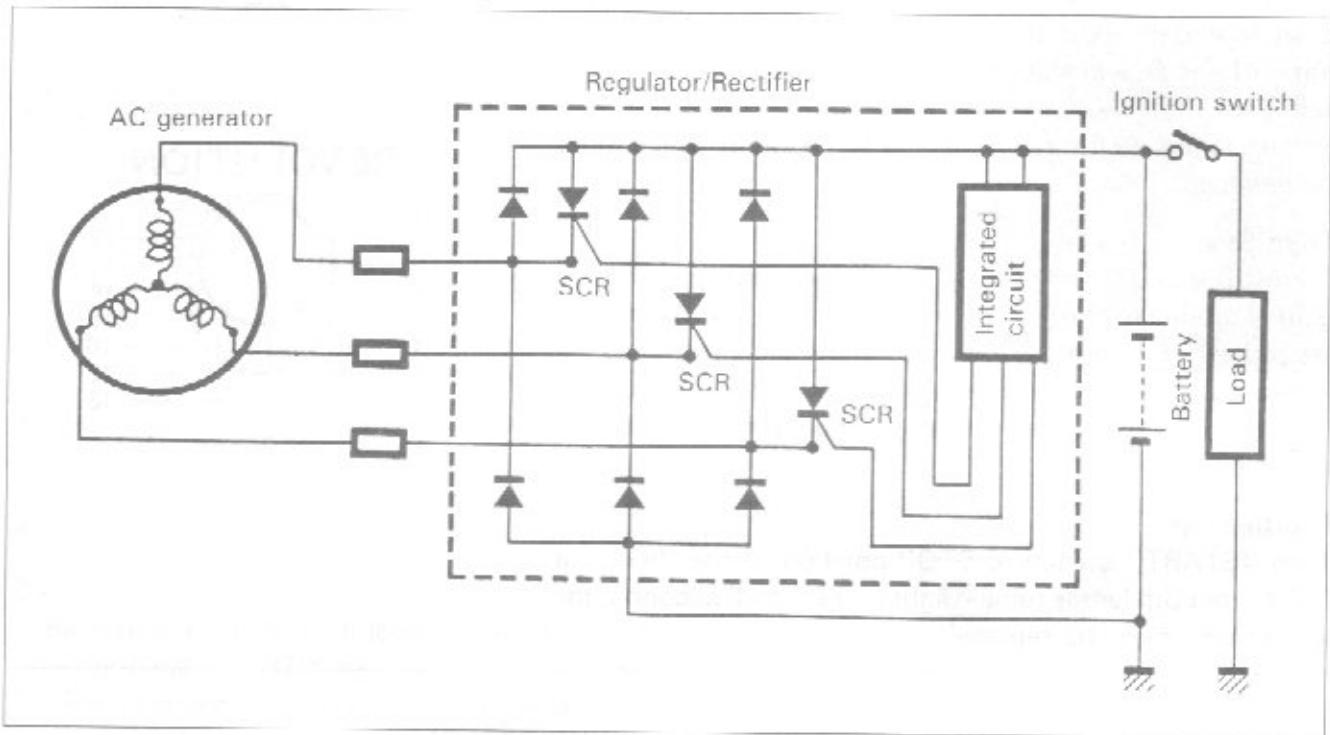

### FUNCTION OF REGULATOR

While the engine r/min is low and the generated voltage of the AC generator is lower than the adjusted voltage of regulator, the regulator does not function. However, the generated current charges the battery directly at this time.

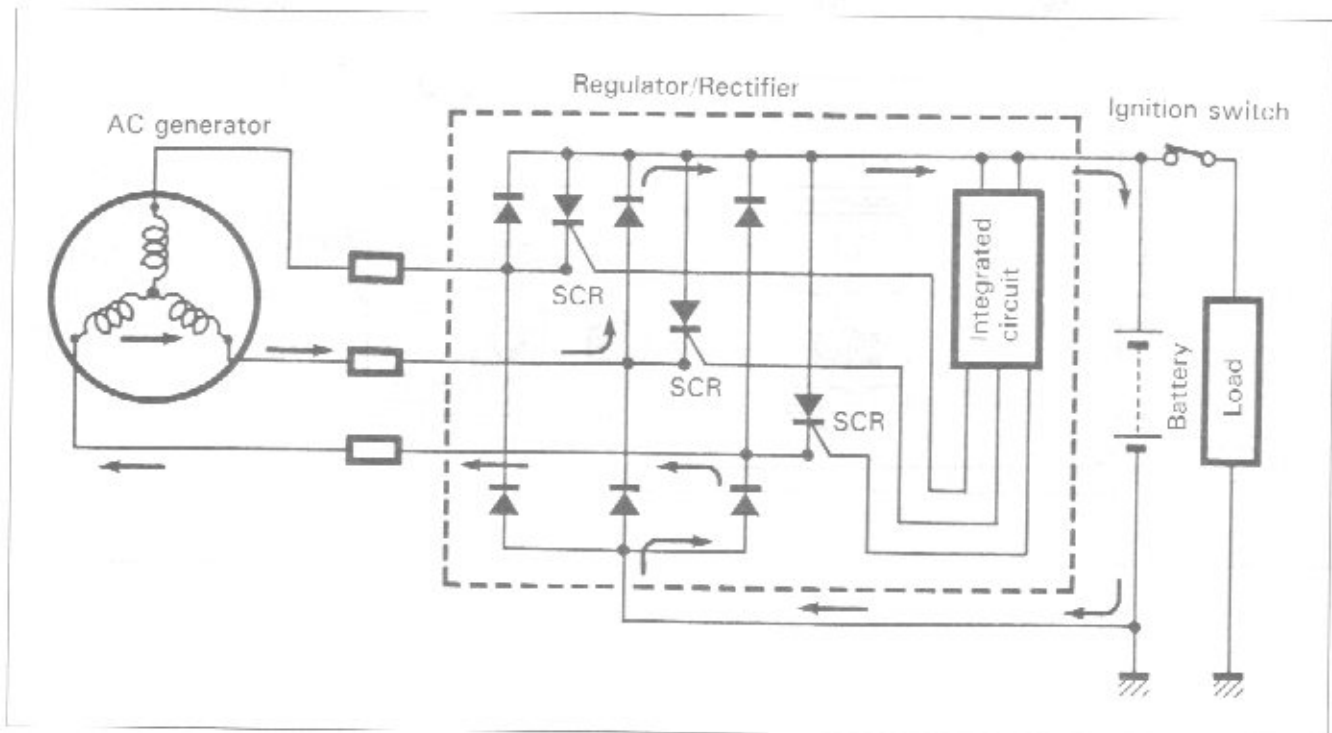

When the engine r/min becomes higher, the generated voltage of the AC generator also becomes higher and the voltage between the battery terminals becomes high accordingly. When it reaches the adjusted voltage of the I.C. (Integrated Circuit) and it is turned "ON", a signal will be sent to the SCR (Thyristor) gate probe and the SCR will be turned "ON".

Then, the SCR becomes conductive in the direction from point (A) to point (B). At this time, the current generated from the AC generator gets through the SCR without charging the battery and returns to AC generator again. At the end of this state, since the AC current generated from AC generator flows to point (B), the reverse current tends to flow to SCR. Then, the circuit of SCR turns to the OFF mode and begins to charge the battery again. Thus these repetitions maintain charging voltage and current to the battery constant and protect it from overcharging.

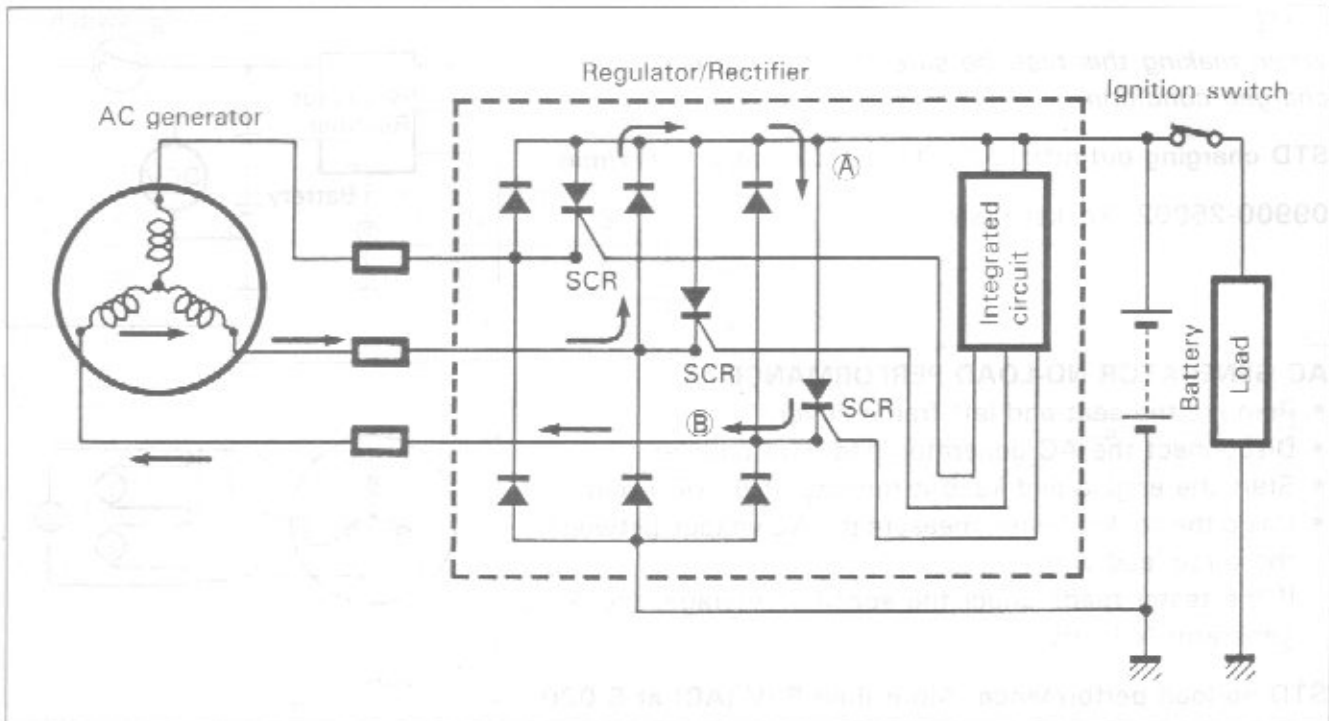

## INSPECTION

### CHARGING OUTPUT CHECK

- Remove the seat and lift the front end of trunk.
- Start the engine and keep it running at 5 000 r/min with lighting switch turned ON and dimmer switch turned HI position.
- Using the pocket tester, measure the DC voltage between the battery terminals,  $\oplus$  and  $\ominus$ .
- If the tester reads under 13.5V or over 15.5V, check the AC generator no-load performance and regulator/rectifier.

#### NOTE:

When making this test, be sure that the battery is fully-charged condition.

**STD charging output: 13.5–15.5V (DC) at 5 000 r/min**

**09900-25002: Pocket tester**

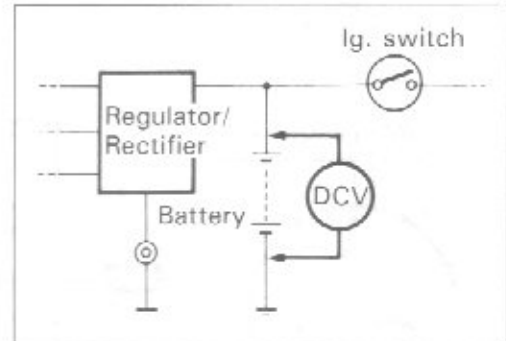
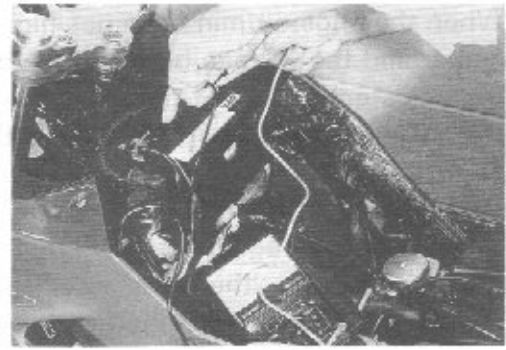

### AC GENERATOR NO-LOAD PERFORMANCE

- Remove the seat and left frame cover.
  - Disconnect the AC generator lead wire coupler.
  - Start the engine and keep it running at 5 000 r/min.
  - Using the pocket tester, measure the AC voltage between the three lead wires.
- If the tester reads under the specified voltage, the AC generator is faulty.

**STD no-load performance: More than 50V (AC) at 5 000 r/min (When engine cold.)**

**09900-25002: Pocket tester**

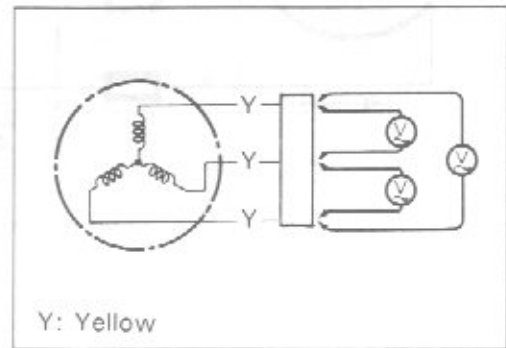

### AC GENERATOR CONTINUITY CHECK

- Using the pocket tester, check the continuity between the three lead wires.
- Check that there is no continuity between the lead wires and ground.

**09900-25002: Pocket tester**

#### NOTE:

When making above test, it is not necessary to remove the AC generator.

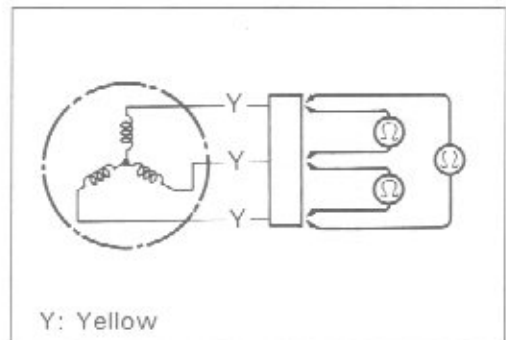

**REGULATOR/RECTIFIER**

- Remove the seat and left air cleaner side cover.
- Disconnect the AC generator lead wire coupler.
- Using the pocket tester (x 1 k $\Omega$  range), measure the resistance between the lead wires in the following table. If the resistance checked is incorrect, replace the regulator/rectifier.

09900-25002: Pocket tester

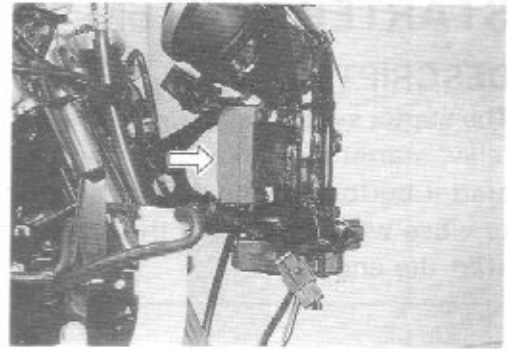
Unit: Approx. k $\Omega$ 

⊖ Probe of tester to:	⊕ Probe of tester to:				
	B <sub>1</sub>	B <sub>2</sub>	B <sub>3</sub>	B/R	B/W
B <sub>1</sub>		$\infty$	$\infty$	3	$\infty$
B <sub>2</sub>	$\infty$		$\infty$	3	$\infty$
B <sub>3</sub>	$\infty$	$\infty$		3	$\infty$
B/R	$\infty$	$\infty$	$\infty$		$\infty$
B/W	3	3	3	4	

B: Black, B/R: Black with Red tracer,  
 B/W: Black with White tracer,  
 $\infty$ : Infinity

**NOTE:**

As transistors, capacitors, Zener diodes, etc. are used inside this regulator/rectifier, the resistance values will differ when an ohmmeter other than the SUZUKI pocket tester is used.

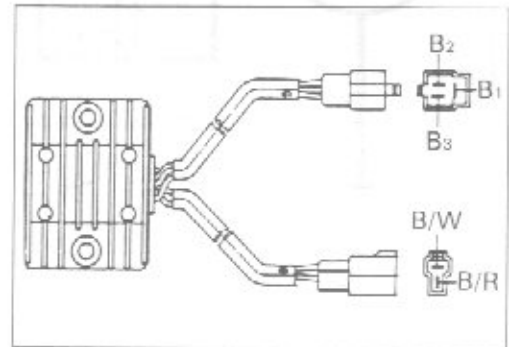

## STARTER SYSTEM

### DESCRIPTION

The starter system is shown in the diagram below: namely, the starter motor, starter relay, side stand relay, starter button, engine stop switch, side stand switch, IG switch and battery. Depressing the starter button (on the right handlebar switch box) energizes the relay, causing the contact points to close which connects the starter motor to the battery. The motor draws about 80 amperes to start the engine.

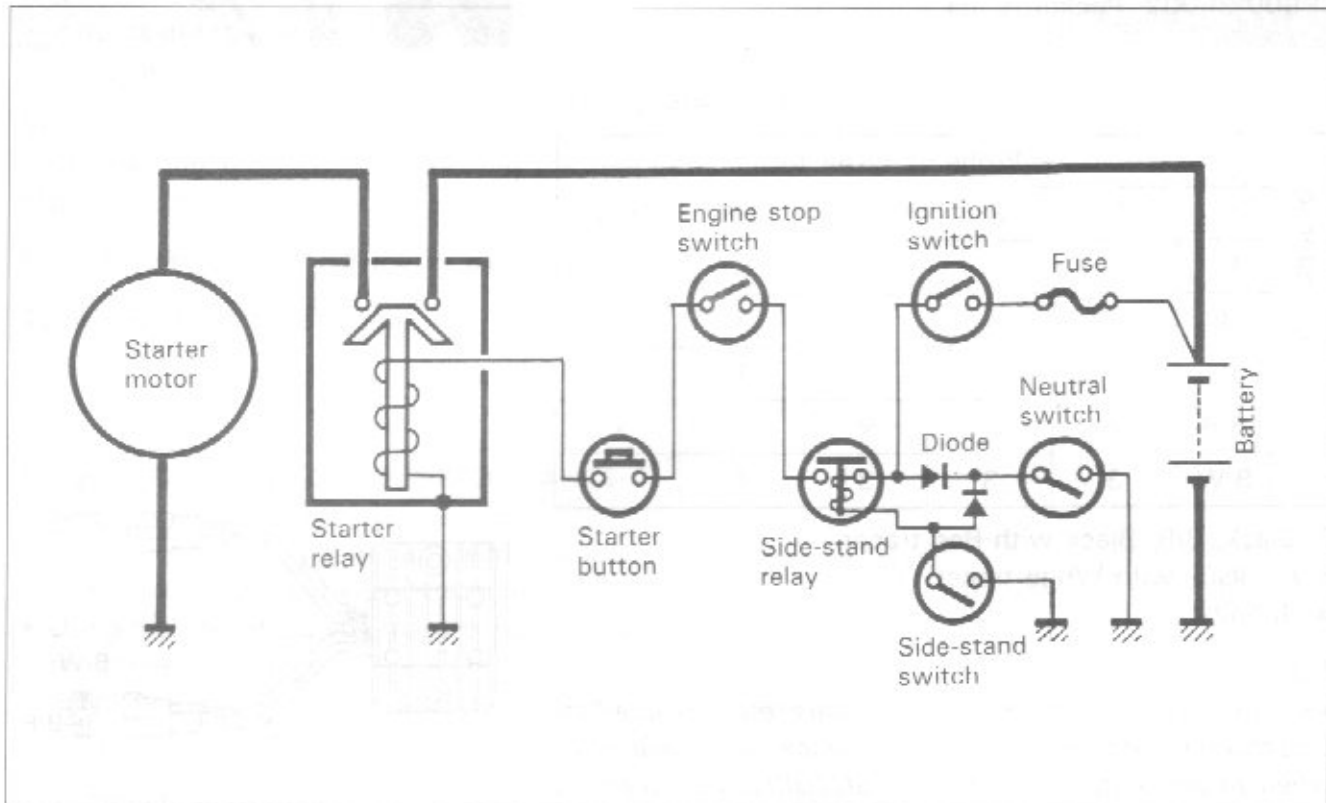

### REMOVAL AND DISASSEMBLY

- Remove the air cleaner and carburetor. (Refer to page 3-6.)
- Remove the starter motor by removing the lead wire and mounting bolts.

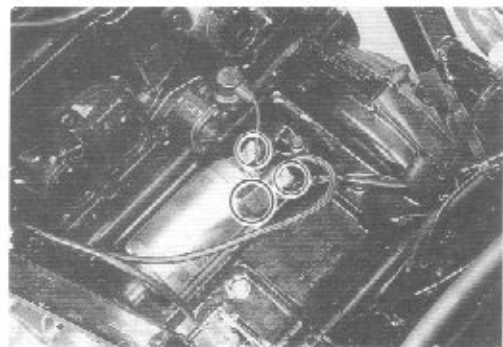



- Disassemble the starter motor as shown in the illustration.

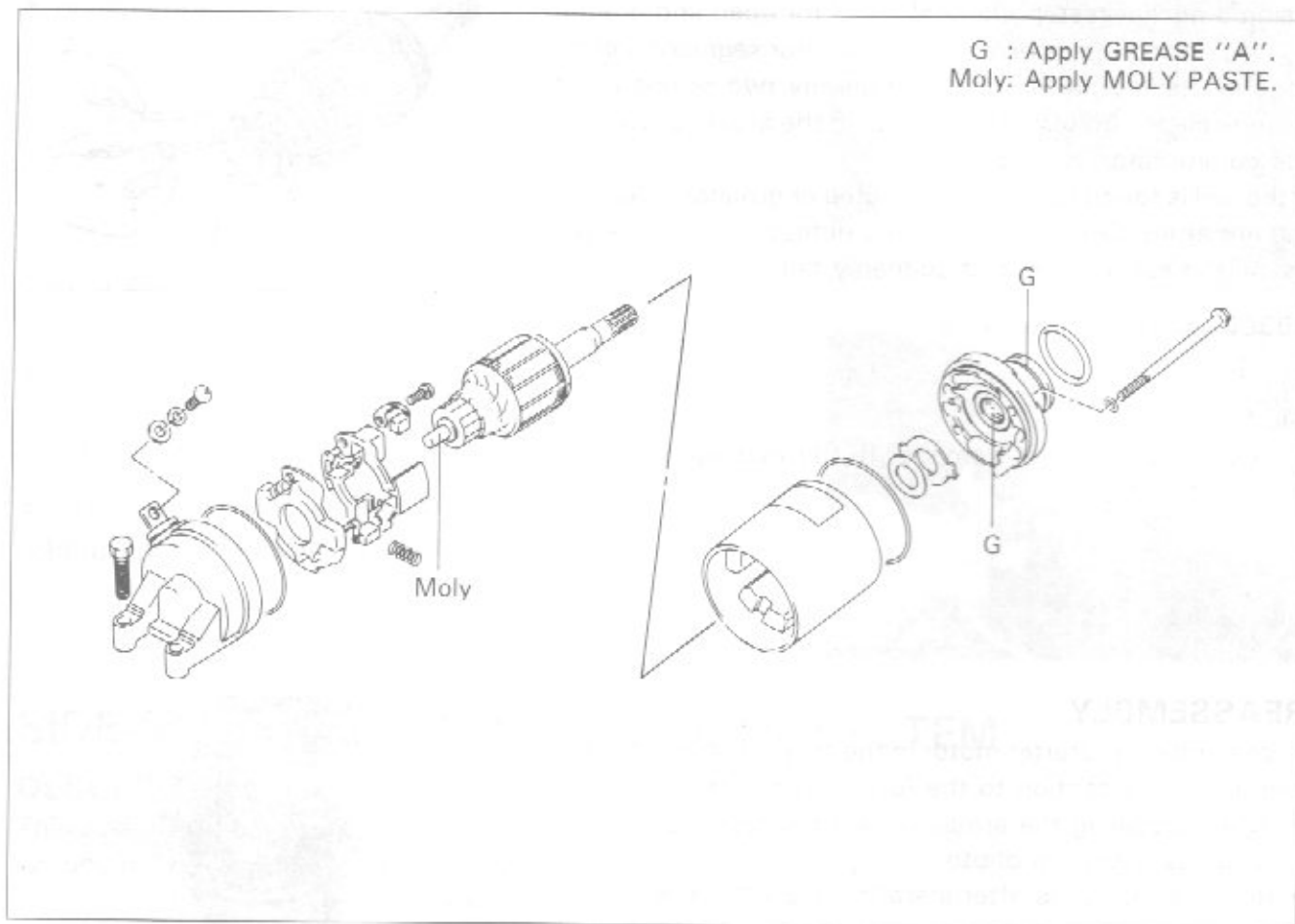

## INSPECTION

### CARBON BRUSH

When the brushes are worn, the motor will be unable to produce sufficient torque, and the engine will be difficult to turn over. To prevent this, periodically, measure the length of the brushes with a vernier calipers, replacing them when they are too short or chipping.

**Service Limit: 3.5 mm (0.14 in)**

**09900-20101: Vernier calipers**

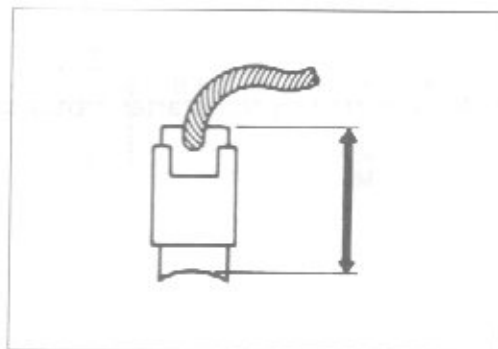

### COMMUTATOR

If the commutator surface is dirty, starting performance decreases. Polish the commutator with # 400 or similar fine emery paper when it is dirty. After polishing it, wipe the commutator with a clean dry cloth.

Measure the commutator under cut ① with a vernier calipers.

**Service Limit: 0.2 mm (0.008 in)**

**09900-20101: Vernier calipers**

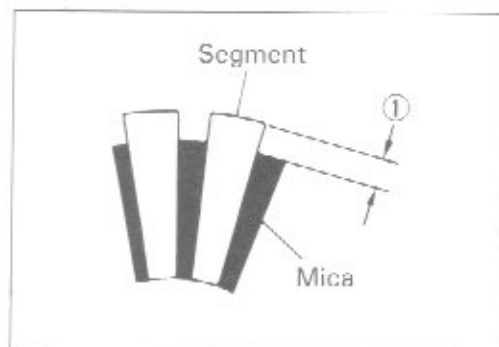

### ARMATURE COIL

Using a pocket tester, check the coil for open and ground by placing probe pins on each commutator segment and rotor core (to test for ground) and on any two segments at various places (to test for open), with the brushes lifted off the commutator surface.

If the coil is found to be open-circuited or grounded, replace the armature. Continuous use of a defective armature will cause the starter motor to suddenly fail.

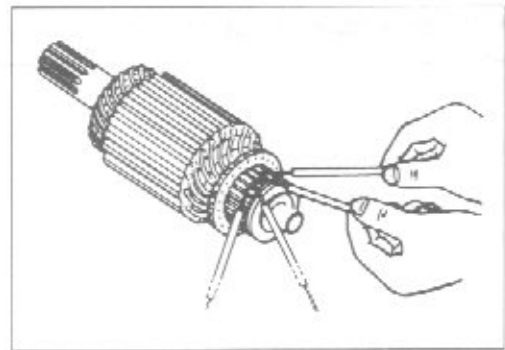

**09900-25002: Pocket tester**

### OIL SEAL

Check the seal lip for damage. If any damage is found, replace it.

### REASSEMBLY

Reassemble the starter motor in the reverse order of disassembly. Pay attention to the following points:

- When installing the armature, set the brushes with the wires as shown in photo.
- Remove the wires after installing the armature.

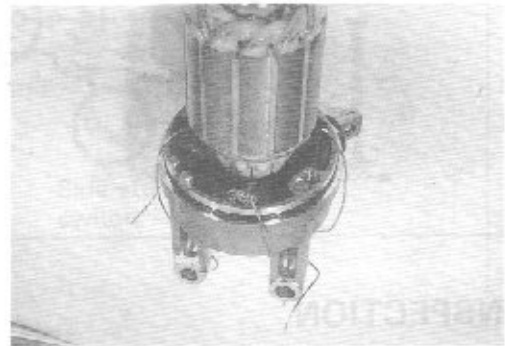

- When installing the starter motor case, align the lines.



## STARTER RELAY INSPECTION

- Remove the seat, and lift the front end of trunk.
- Disconnect the lead wire of starter motor at starter relay.
- Turn on the ignition switch, inspect the continuity between the terminals, positive and negative, when pushing the starter button.

If the starter relay is in sound condition, continuity is found.

### 09900-25002: Pocket tester

- Disconnect the lead wire coupler from the starter relay.
- Check the coil for "open", "ground" and ohmic resistance. The coil is in in good condition if the resistance is as follows.

Starter relay resistance: 2–6  $\Omega$

### 09900-25002: Pocket tester

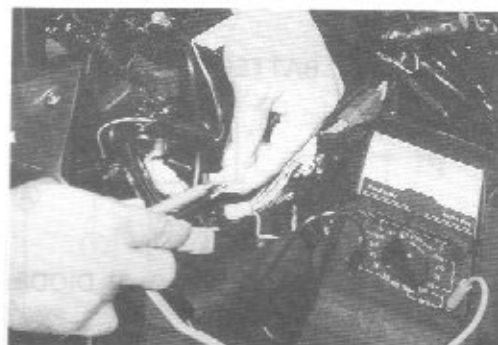
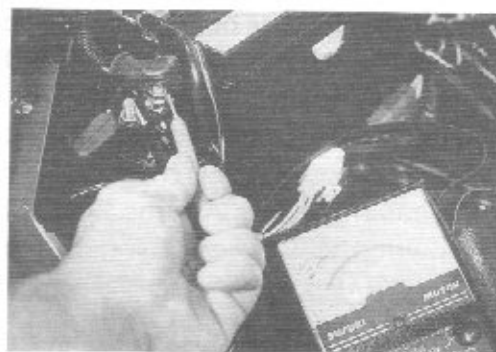

## SIDE-STAND/IGNITION INTERLOCK SYSTEM

### DESCRIPTION

This side stand/ignition interlock system is to prevent starting the motorcycle with the side stand left down. The system is operated by an electric circuit provided between the battery and ignition coil.

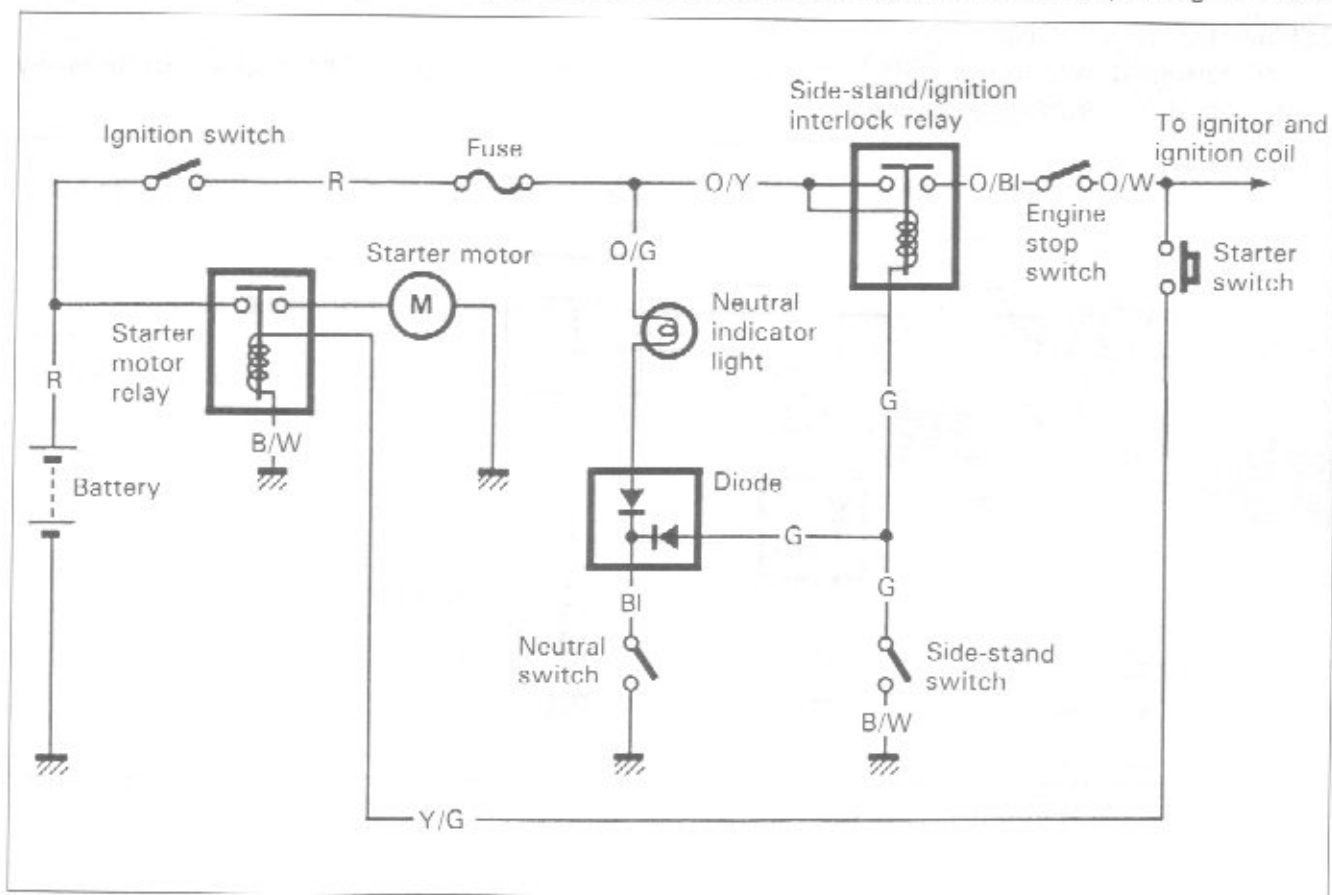

The circuit consists of relay, lamp, diode and switches and decides to live the ignition coil depending on the position of the TRANSMISSION and SIDE-STAND with the neutral and side-stand switches working mutually.

The ignition coil lives only in two situations as follows:

1. Transmission: "NEUTRAL (ON)" Side-stand: "DOWN (OFF)"

The current flow (A) turns "ON" the relay and the ignition coil lives even the side-stand is kept down. This is for warming up the engine.

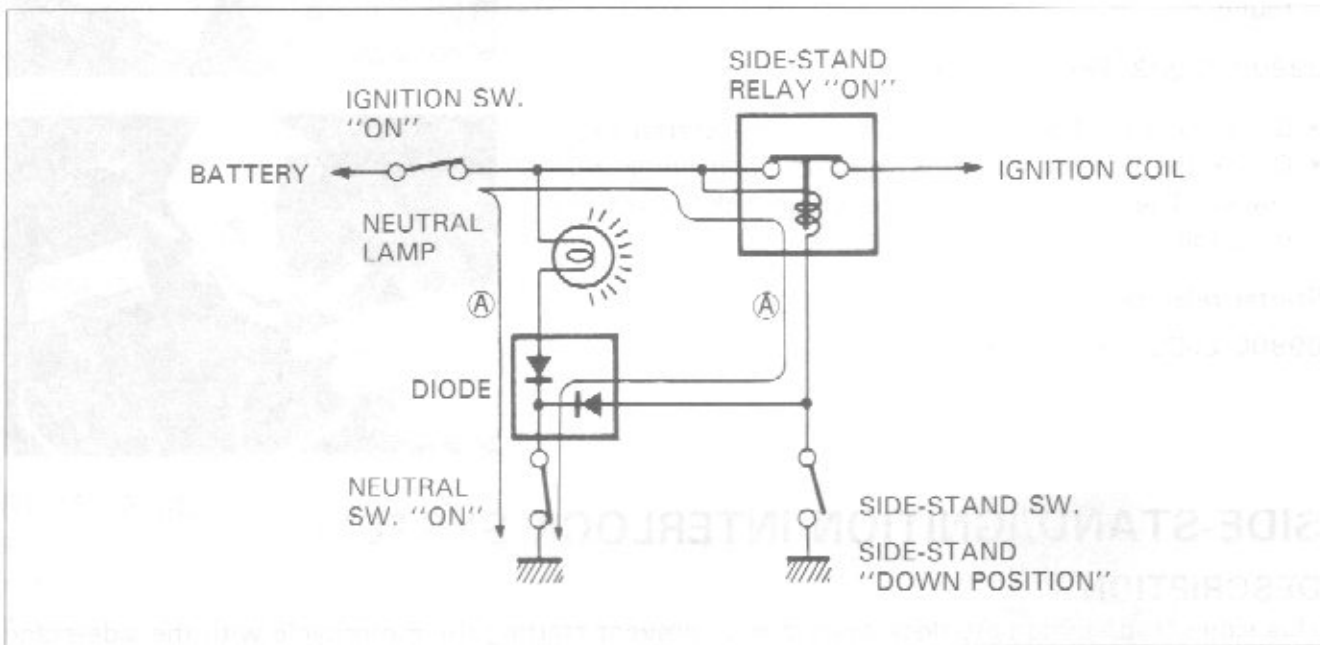

2. Side-stand: "UP (ON)"

The current flow (B) turns "ON" the relay and the ignition coil lives. The engine can be easily started at any transmission position.

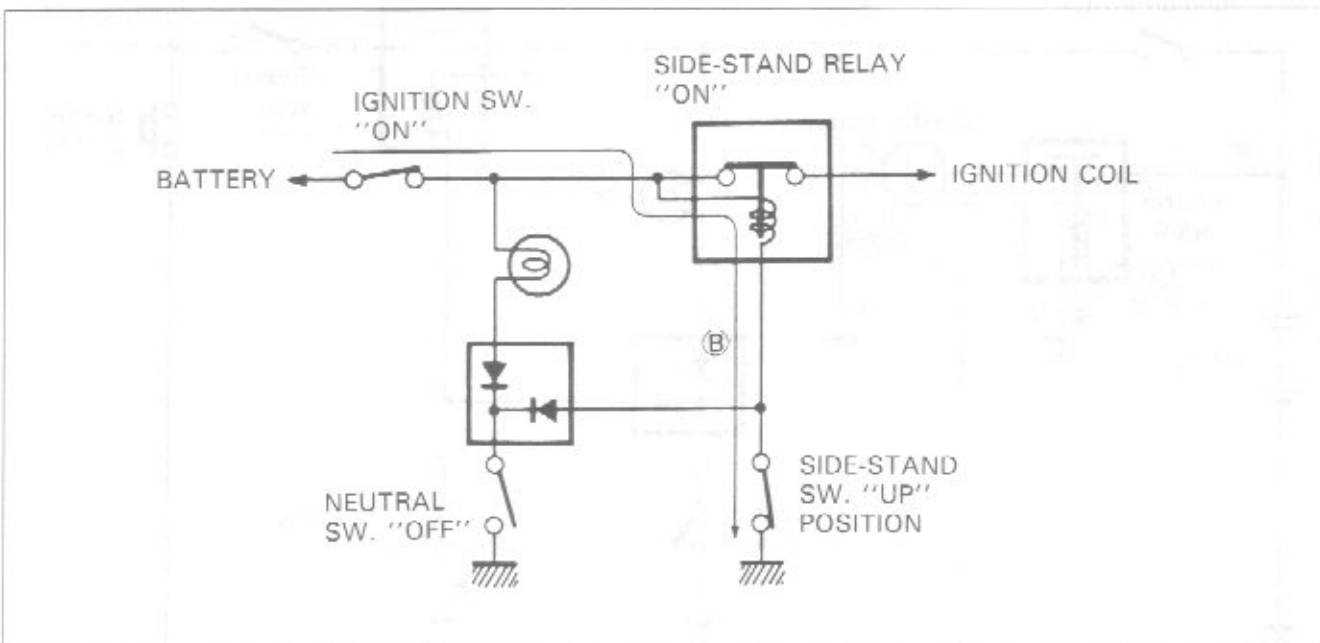

## INSPECTION

If the interlock system does not operate properly, check each component. If any abnormality is found, replace the component with a new one.

### 09900-25002: Pocket tester

#### Diode **A**

The diode can pass current only in one direction.

- Check the continuity between ① and ②. If one way continuity, the diode is in good condition.
- Also check the continuity between ② and ③ as required.

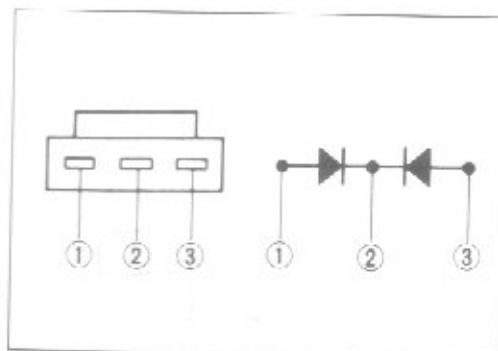

#### Neutral switch **B**

Check the neutral switch continuity with the pocket tester. (Refer to page 6-19.)

#### Side-stand switch **C**

Check the side-stand switch continuity with the pocket tester. (Refer to page 6-19.)

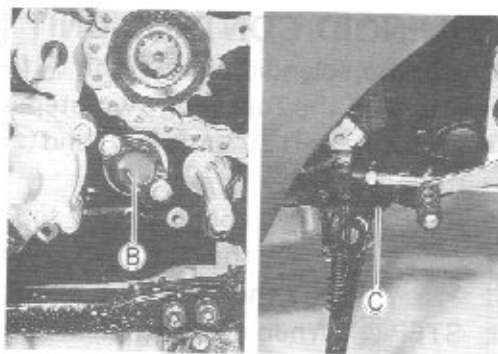

#### Side-stand/ignition interlock relay **D**

First, check the insulation between ① and ② terminals with pocket tester. Then apply 12 volts to ③ and ④ terminals, (+) to ③ and (-) to ④, and check the continuity between ① and ②.

If there is no continuity, replace it with a new one.

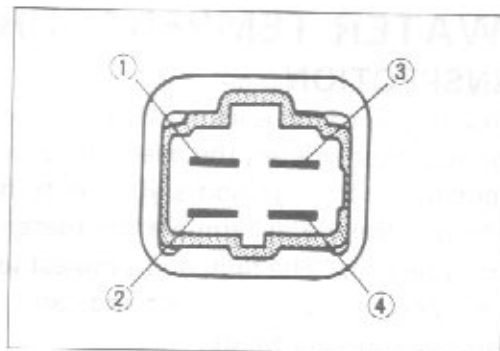

## FRONT AND REAR SOLENOID AND CONTROL UNIT

### FRONT AND REAR SOLENOID INSPECTION

Measure the solenoid resistance with the pocket tester.

S.T.D. resistance: 0.7–1.5  $\Omega$

09900-25002: Pocket tester

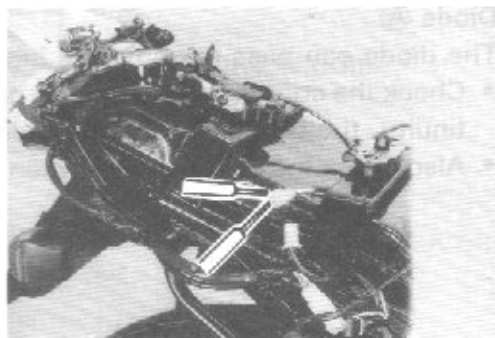
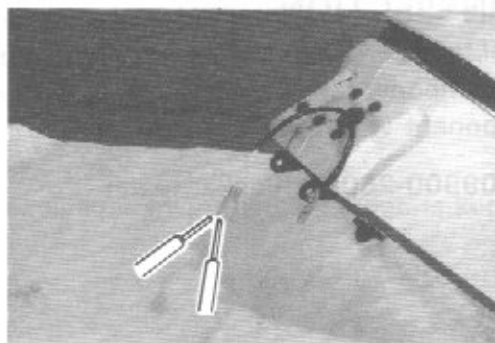

### SOLENOID CONTROL UNIT INSPECTION

Check the solenoid control unit (A) for continuity in accordance with the following two steps.

- Connect the 12V battery (1) and (2) as shown in the illustration.

STEP ①: When applying 12 V to C and D terminals, and check the continuity, A and C terminals are ON and then will OFF about 2 sec later.

STEP ②: When applying 12 V to B and D terminals, and check the continuity A and B terminals are ON and then will OFF about 2 sec later.

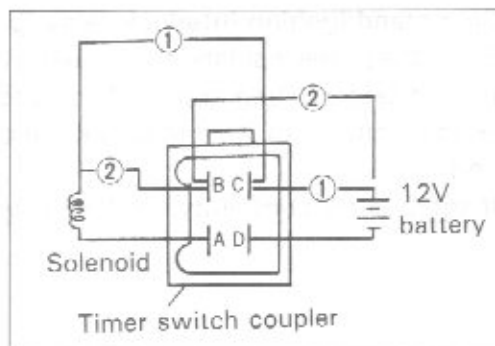

## WATER TEMPERATURE METER INSPECTION

As the coil spring is installed on the needle shaft of the water temperature meter, the needle is forced back to the original position when ignition switch is turned OFF.

To test the water temperature meter two different checks may be used. The first, and simplest test will tell if the meter is operating but will not indicate the meters accuracy throughout the range.

To perform this test, disconnect the B/G lead wire of the water temperature meter from the water thermo-gauge. Connect a jumper wire between B/W wires coming from the main wiring harness and engine ground. With the ignition switch turned on, the water temperature meter should indicate "H". The second test will check the accuracy of the meter in the "H" and "C" positions.

Connect a 167-ohm resistor between the B/G lead wire of the water thermo-gauge and the ground lead wire. The water thermo-gauge is normal if its pointer indicates the "C" position when the specified voltage is applied to the circuit and if its pointer indicates the "H" position when the resistor is changed to 17 ohms. If either one or both indications are abnormal, replace the water temperature meter with a new one.

### WATER TEMPERATURE METER

POSITION	TEMP	RESISTANCE
①	50°C	167 Ω
②	115°C	17 Ω

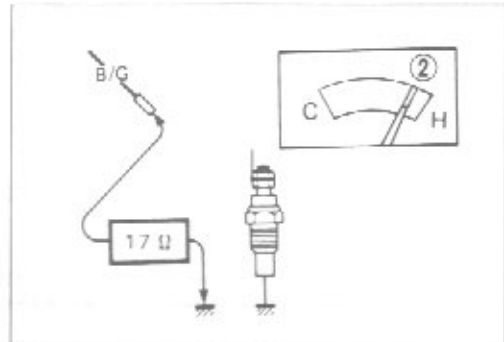
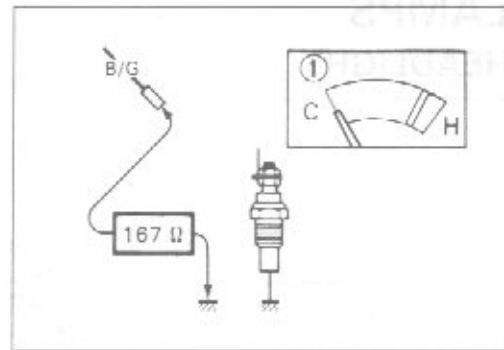

### COMBINATION METER

- Disassemble the combination meter as follows.

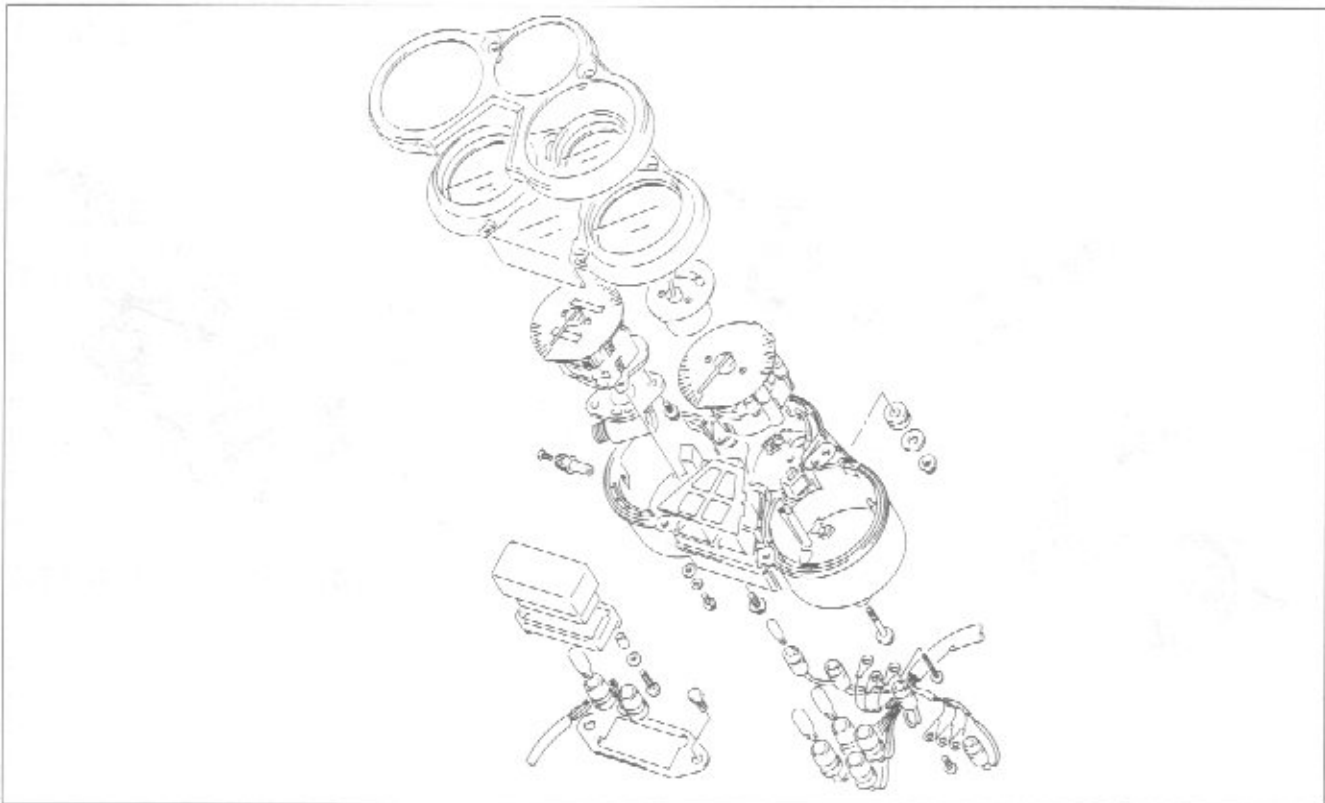

# LAMPS

## HEADLIGHT

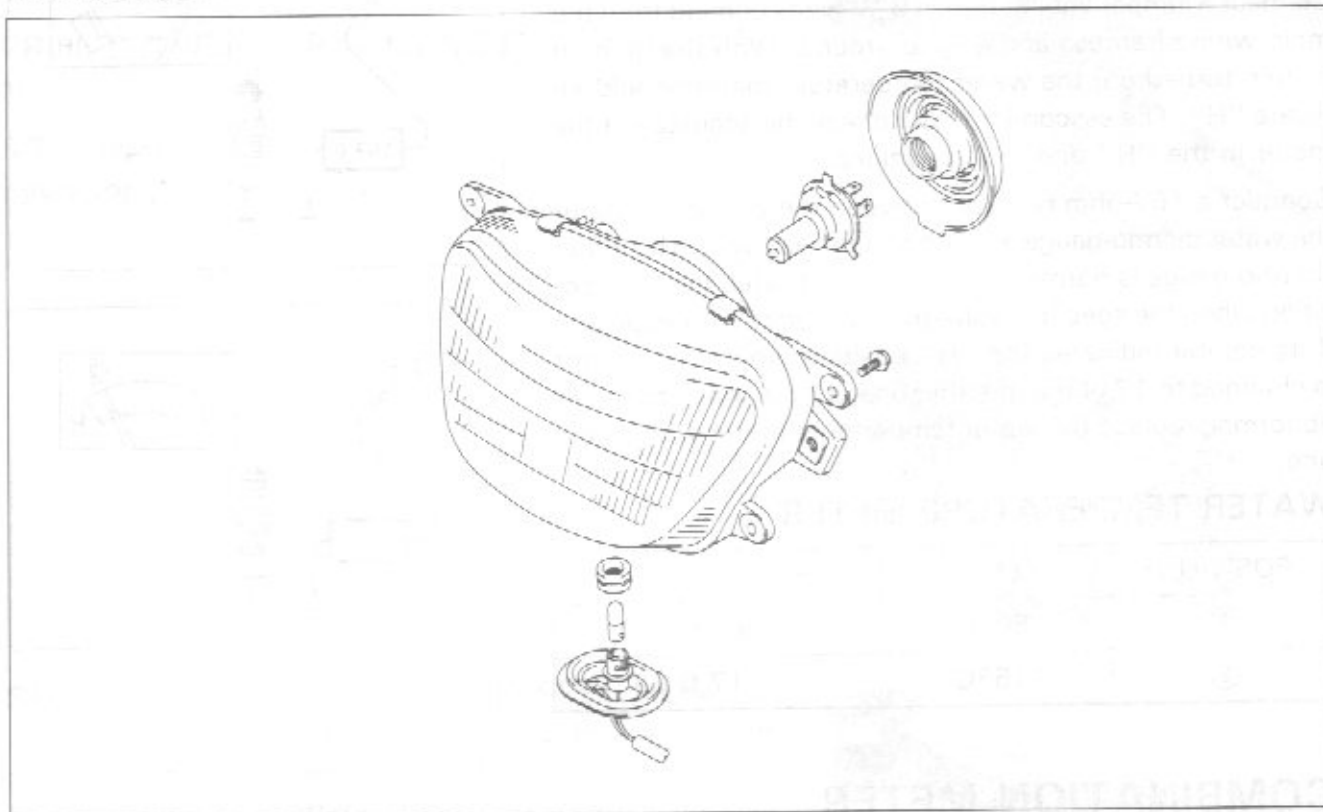

## FRONT AND REAR TURN SIGNAL LIGHTS AND TAIL/BRAKE LIGHT

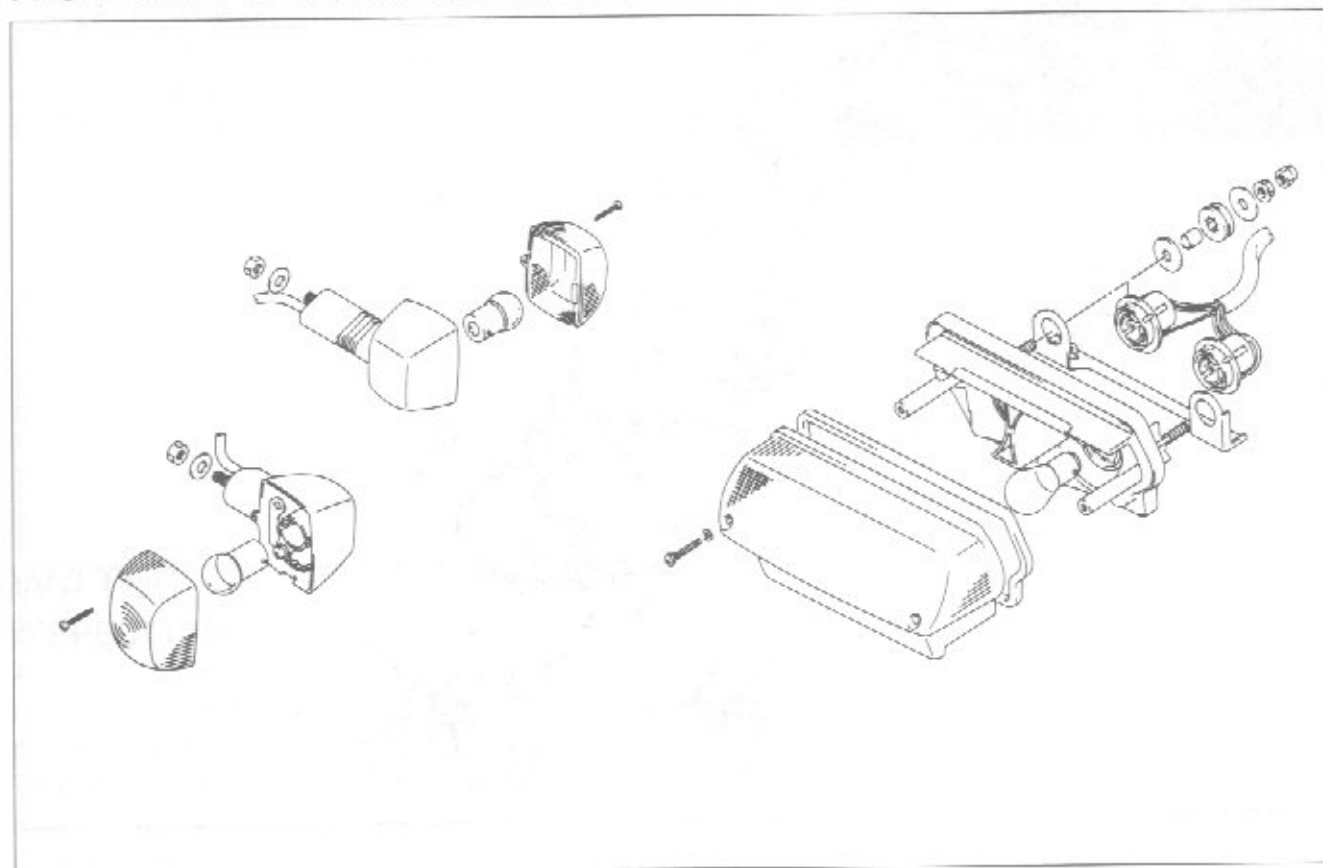



# SWITCHES

Inspect each switch for continuity with the pocket tester referring to the chart. If any abnormality is found, replace the respective switch assemblies with new ones.

09900-25002: Pocket tester

## IGNITION SWITCH

	R	O	O/G	O/Bl	Gr	Br
OPEN	○—○	○—○	○		○—○	○—○
ON	○—○	○			○—○	○—○
FUEL	○			○		
OFF						
LOCK						
P	○—○					○

## LIGHTING SWITCH

	Gr	O/Bl	O/R	Y/W
OFF				
S	○—○	○—○		
ON	○—○	○—○	○—○	○—○

## DIMMER SWITCH

	Y/W	W	Y
HI	○—○	○—○	○—○
LO	○—○	○—○	

## TURN SIGNAL LIGHT SWITCH

	Lg	Lbl	B
R	○—○	○—○	
•			
L		○—○	○—○

## STARTER BUTTON

	O/W	Y/G
OFF		
ON (Push)	○—○	○—○

## HORN BUTTON

	B/Bl	B/W
OFF		
ON (Push)	○—○	○—○

## PASSING LIGHT SWITCH

	O/R	Y
OFF		
ON (Push)	○—○	○—○

## ENGINE STOP SWITCH

	O/W	O/B
OFF		
ON	○—○	○—○

## FRONT BRAKE SWITCH

	O	W/B
OFF		
ON	○—○	○—○

## REAR BRAKE SWITCH

	O	W/B
OFF		
ON	○—○	○—○

## TRUNK LIGHT SWITCH

	R	B/W
OFF		
ON (Push)	○—○	○—○

**NEUTRAL SWITCH**

	Bl	Ground
OFF		
ON		

**REAR SOLENOID SWITCH**

	O/Bl	G
OFF		
ON (Push)		

**SIDE STAND SWITCH**

	G	B/W
ON (Upright position)		
OFF (Down position)		

**WIRE COLOR**

- B..... Black
- Bl..... Blue
- Br..... Brown
- G..... Green
- Gr..... Gray
- Lbl..... Light blue
- Lg..... Light green
- O..... Orange
- R..... Red
- W..... White
- Y..... Yellow
- B/Bl..... Black with Blue tracer
- B/W..... Black with White tracer
- O/B..... Orange with Black tracer
- O/Bl..... Orange with Blue tracer
- O/G..... Orange with Green tracer
- O/R..... Orange with Red tracer
- O/W..... Orange with White tracer
- W/B..... White with Black tracer
- Y/G..... Yellow with Green tracer
- Y/W..... Yellow with White tracer

## BATTERY SPECIFICATIONS

Type designation	YTX7A-BS or FTX7A-BS
Capacity	12 V 21.6 kC (6 Ah)/10HR
Standard electrolyte S.G.	1.320 at 20°C (68°F)

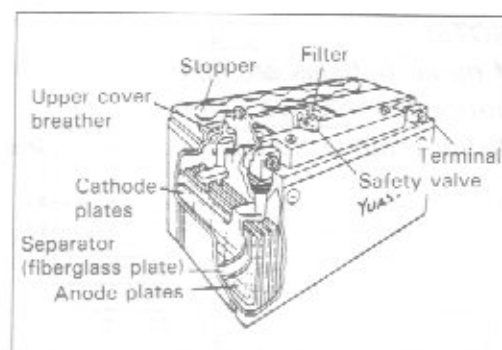

## INITIAL CHARGING

### Filling electrolyte

- Remove the aluminum tape ① sealing the battery electrolyte filler holes.

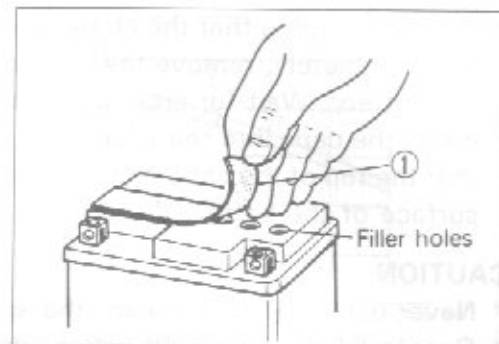

- Remove the caps ②.

### NOTE:

- After filling the electrolyte completely, use the removed cap ② as the sealed caps of battery-filler holes.
- Do not remove or pierce the sealed areas ③ of the electrolyte container.



- Insert the nozzle of the electrolyte container into the battery's electrolyte filler holes, holding the container firmly so that it does not fall. Take precaution not to allow any of the fluid to spill.

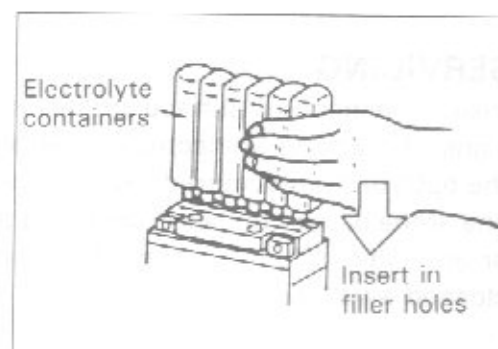

- Make sure air bubbles are coming up each electrolyte container, and leave in this position for about more than 20 minutes.

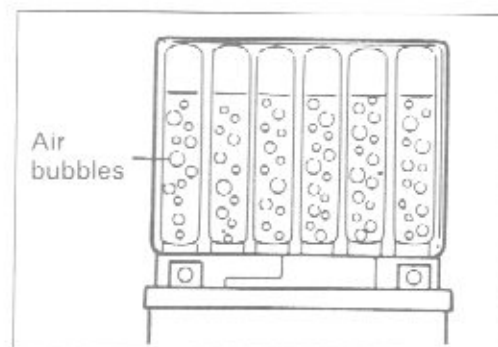

**NOTE:**

If no air bubbles are coming up from a filler port, tap the bottom of the two or three times.

Never remove the container from the battery.

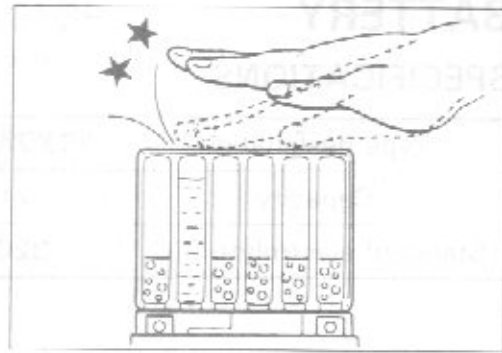

- After confirming that the electrolyte has entered the battery completely, remove the electrolyte containers from the battery. Wait for around 20 minutes.
- Insert the caps into the filler holes, pressing in firmly so that the top of the caps do not protrude above the upper surface of the battery's top cover.

**CAUTION:**

- \* Never uses anything except the specified battery.
- \* Once install the caps to the battery; do not remove the caps.
- Using SUZUKI pocket tester, measure the battery voltage. The tester should indicate more than 12.5–12.6 V (DC) as shown in the Fig. If the battery voltage is lower than the specification, charge the battery with a battery charger. (Refer to the recharging operation.)

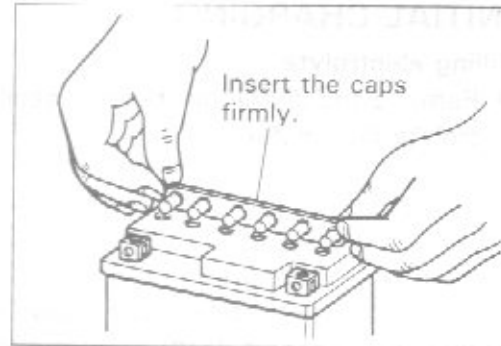
**NOTE:**

Initial charging for a new battery is recommended if two years have elapsed since the date of manufacture.

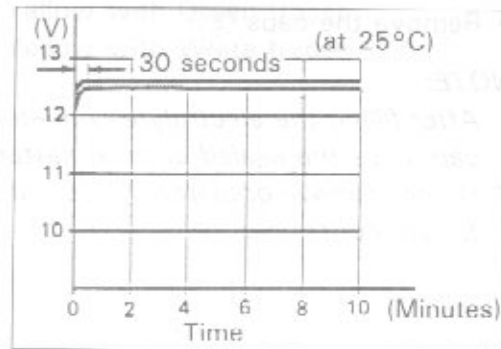
**SERVICING**

Visually inspect the surface of the battery container. If any signs of cracking or electrolyte leakage from the sides of the battery have occurred, replace the battery with a new one. If the battery terminals are found to be coated with rust or an acidic white powdery substance, then this can be cleaned away with sandpaper.



## RECHARGING OPERATION

- Using the pocket tester, check the battery voltage. If the voltage reading is less than the 12.0 V (DC), recharge the battery with a battery charger.

### CAUTION:

When recharging the battery, remove the battery from the motorcycle.

### NOTE:

Do not remove the stoppers on the battery top while recharging.

Recharging time: 3 A for one hour or 0.7 A for 5 hours

### CAUTION:

Be careful not to permit the charging current to exceed 3 A at any time.

- After recharging, wait for more than 30 minutes and check the battery voltage with a pocket tester.
- If the battery voltage is less than the 12.5 V, recharge the battery again.
- If battery voltage is still less than 12.5 V, after recharging, replace the battery with a new one.
- When a battery is left for a long term without using, it is subject to discharge. When the motorcycle is not used for more than 1 month (especially during the winter season), recharge the battery once a month at least.

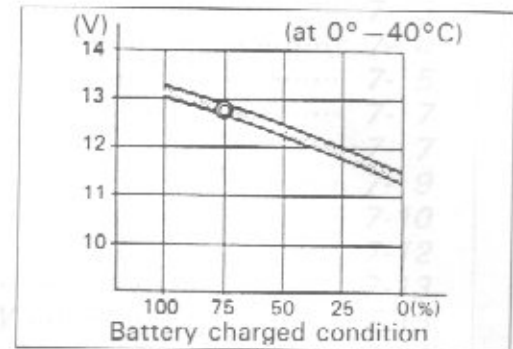
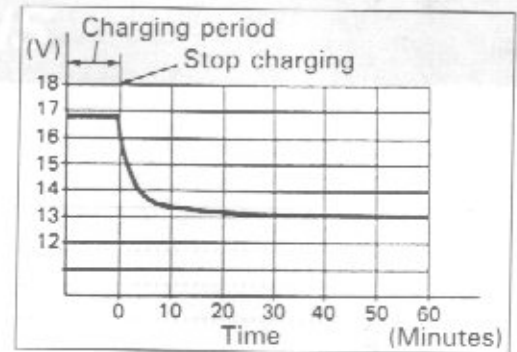

# CHASSIS

## CONTENTS

<b>FAIRING</b> .....	7- 1
<b>REMOVAL</b> .....	7- 1
<b>REMountING</b> .....	7- 2
<b>FRONT WHEEL</b> .....	7- 3
<b>REMOVAL</b> .....	7- 3
<b>INSPECTION AND DISASSEMBLY</b> .....	7- 4
<b>REASSEMBLY AND REMOUNTING</b> .....	7- 5
<b>TIRE AND WHEEL</b> .....	7- 7
<b>TIRE REMOVAL</b> .....	7- 7
<b>INSPECTION</b> .....	7- 9
<b>TIRE MOUNTING</b> .....	7-10
<b>FRONT BRAKE</b> .....	7-12
<b>BRAKE PAD REPLACEMENT</b> .....	7-13
<b>CALIPER REMOVAL AND DISASSEMBLY</b> .....	7-13
<b>CALIPER AND DISC INSPECTION</b> .....	7-14
<b>CALIPER REASSEMBLY AND REMOUNTING</b> .....	7-15
<b>DISC INSPECTION</b> .....	7-15
<b>MASTER CYLINDER REMOVAL AND DISASSEMBLY</b> .....	7-15
<b>MASTER CYLINDER INSPECTION</b> .....	7-16
<b>MASTER CYLINDER REASSEMBLY AND REMOUNTING</b> .....	7-17
<b>FRONT FORK</b> .....	7-18
<b>REMOVAL AND DISASSEMBLY</b> .....	7-18
<b>INSPECTION</b> .....	7-20
<b>REASSEMBLY AND REMOUNTING</b> .....	7-21
<b>STEERING STEM</b> .....	7-23
<b>REMOVAL AND DISASSEMBLY</b> .....	7-23
<b>INSPECTION</b> .....	7-25
<b>REASSEMBLY AND REMOUNTING</b> .....	7-25
<b>IGNITION SWITCH</b> .....	7-26
<b>REAR WHEEL</b> .....	7-28
<b>REMOVAL</b> .....	7-28
<b>INSPECTION AND DISASSEMBLY</b> .....	7-29
<b>REASSEMBLY AND REMOUNTING</b> .....	7-30
<b>REAR BRAKE</b> .....	7-31
<b>BRAKE PAD REPLACEMENT</b> .....	7-31
<b>CALIPER REMOVAL AND DISASSEMBLY</b> .....	7-32
<b>CALIPER AND DISC INSPECTION</b> .....	7-33
<b>CALIPER REASSEMBLY AND REMOUNTING</b> .....	7-33
<b>MASTER CYLINDER REMOVAL AND DISASSEMBLY</b> .....	7-34
<b>MASTER CYLINDER INSPECTION</b> .....	7-35
<b>MASTER CYLINDER REASSEMBLY AND REMOUNTING</b> .....	7-35
<b>REAR SWINGARM AND SUSPENSION</b> .....	7-36
<b>REMOVAL</b> .....	7-36
<b>INSPECTION AND DISASSEMBLY</b> .....	7-38
<b>REASSEMBLY AND REMOUNTING</b> .....	7-39
<b>REASSEMBLING INFORMATION</b> .....	7-40

## FAIRING

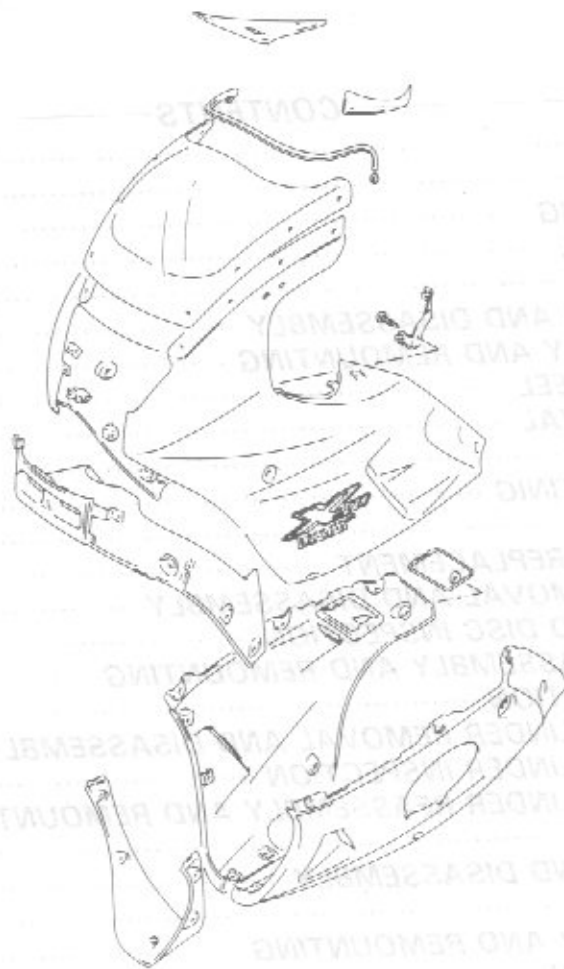

## REMOVAL

- Remove the lower fairing.

- Remove the right fairing panel.

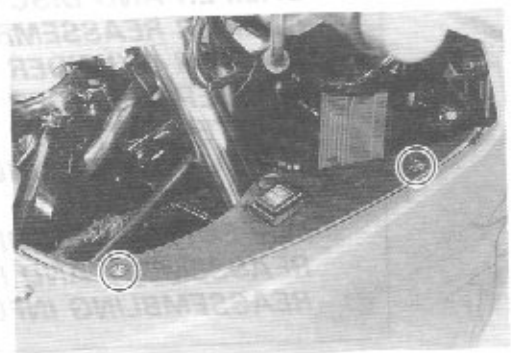
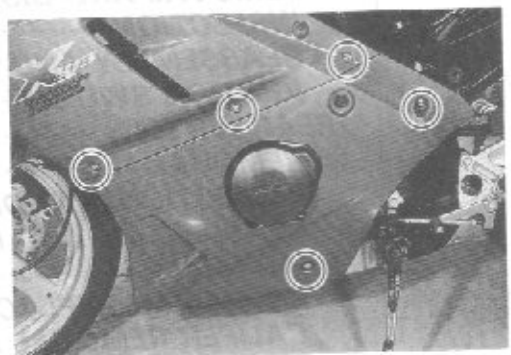

- Disconnect the rear lid opener switch lead wires.

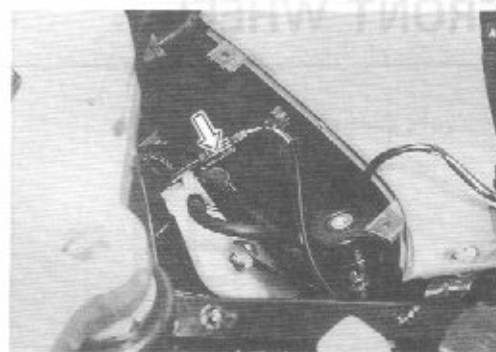

- Remove the rear view mirrors.

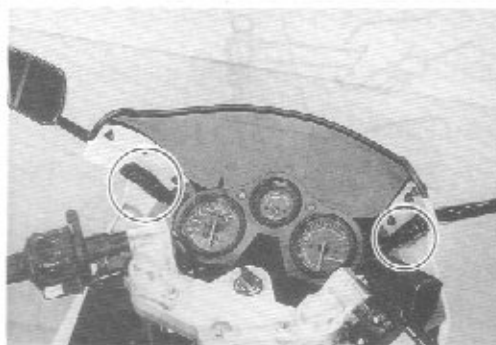

- Disconnect the headlight lead wires, position light lead wires and turn signal light lead wires.

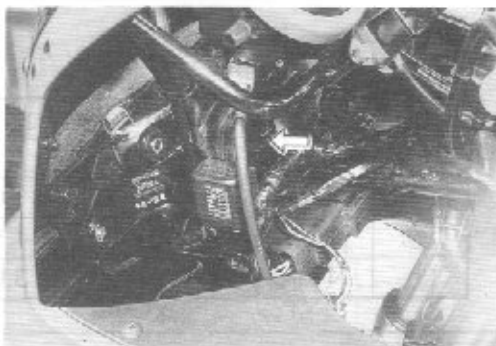

- Remove the headlight mounting bracket bolts.
- Remove the fairing with headlight.

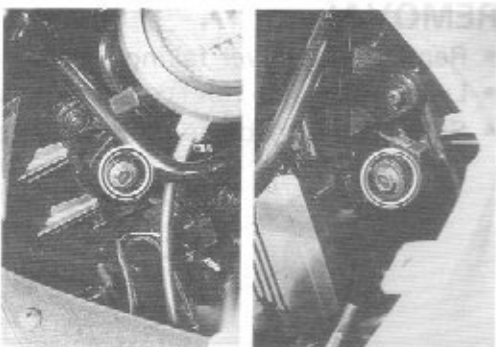

## REMountING

Remount the fairing in the reverse order of removal.

\* Remove the front wheel to adjust the axle nuts.  
 NOTE  
 Do not operate the front brake when re-assembly the front wheel.



## FRONT WHEEL

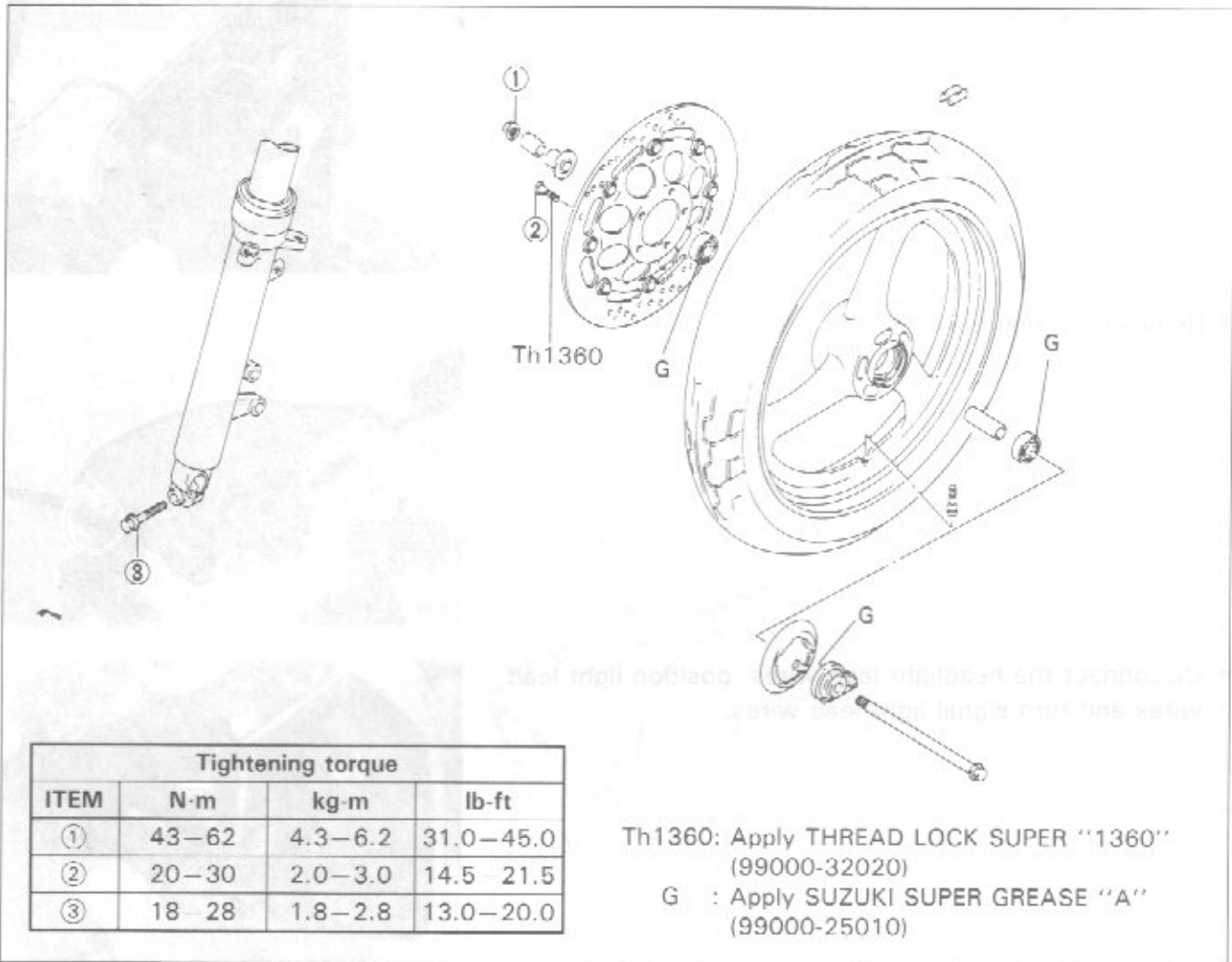

## REMOVAL

- Remove the lower fairing. (Refer to page 7-1.)
- Loosen the axle nut (①) and axle holder bolt (②).
- Support the machine with a jack or wooden block.

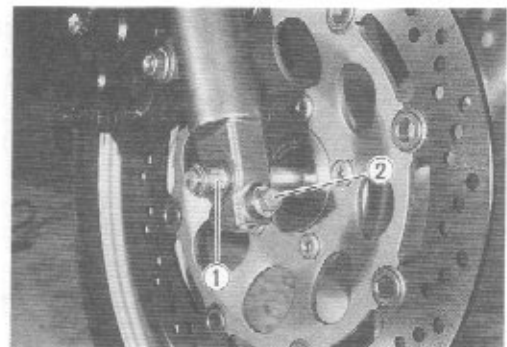

- Remove the front wheel by drawing the axle shaft.

## NOTE:

Do not operate the front brake lever while dismounting the front wheel.

## INSPECTION AND DISASSEMBLY

### WHEEL BEARING

Inspect the play of bearing inner ring by hand while mounted in the wheel.

Rotate the inner ring by hand to inspect if any abnormal noise occurs or rotating smoothly.

Replace the bearing if there is anything unusual.

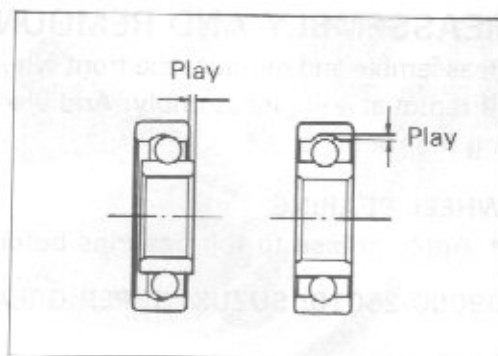

- Drive out both wheel bearings with a appropriate steel bar.

### CAUTION:

The removed bearings should be replaced with new ones.

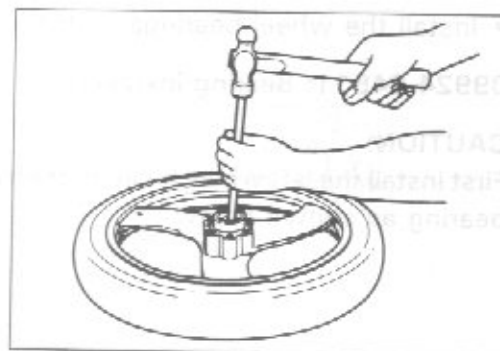

### AXLE SHAFT

Check the axle shaft runout to use a dial gauge. If the runout exceeds limit, replace it with a new one.

**Service Limit: 0.25 mm (0.010 in)**

09900-20606: Dial gauge (1/100 mm)

09900-20701: Magnetic stand

09900-21304: V-block set

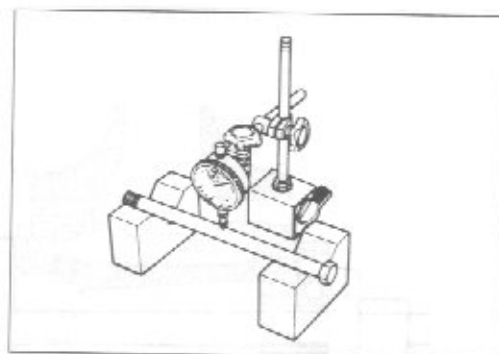

### WHEEL

Inspect the wheel rim runout if it exceeds the limit. An excessive runout is usually due to worn or loosen wheel bearings and can be reduced by replacing them. If the runout does not reduce even replacing bearings, replace the wheel.

**Service Limit: 2.0 mm (0.08 in)**  
(Axial and Radial)

09900-20606: Dial gauge (1/100 mm)

09900-20701: Magnetic stand

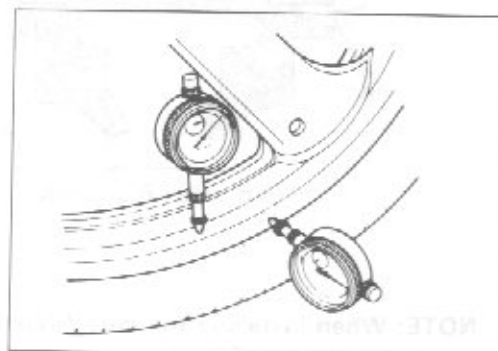

BRAKE DISC

\* Apply THREAD-LITE  
brake disc lock and grease

Tightening torque: 18-28 N·m

(1.8-3.0 kg-m)

9900 02700 THREAD LOCK SPRING

NOTE

Always use the correct torque wrench and torque

specification.

## REASSEMBLY AND REMOUNTING

Reassemble and remount the front wheel in the reverse order of removal and disassembly. And also observe the following instructions:

### WHEEL BEARING

- Apply grease to the bearings before installing.

99000-25010: SUZUKI SUPER GREASE "A"



- Install the wheel bearings with the special tool.

09924-84511: Bearing installer set

### CAUTION:

First install the left wheel bearing, then install the right wheel bearing as shown below.

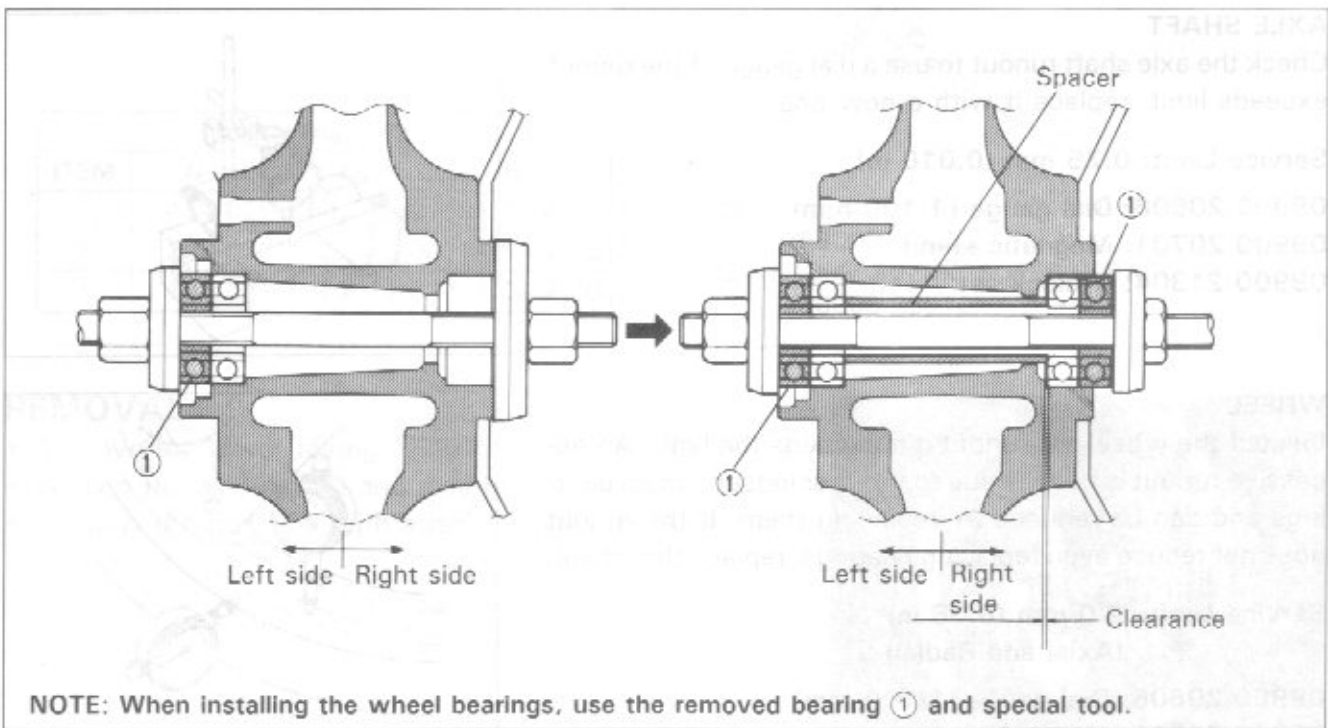
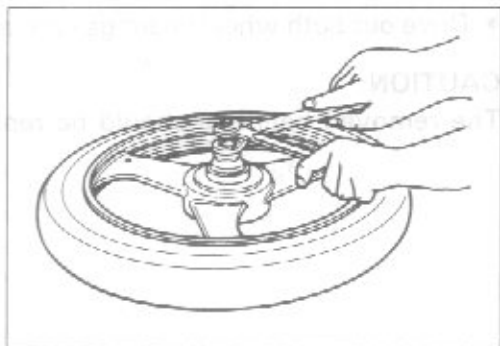

### BRAKE DISC

- Apply THREAD LOCK SUPER "1360" to the thread of brake disc bolts and tighten them to the specified torque.

Tightening torque: 18–28 N·m  
(1.8–2.8 kg·m, 13.0–20.0 lb-ft)

99000-32130: THREAD LOCK SUPER "1360"

### NOTE:

Make sure that the brake disc is clean and free of any greasy matter.

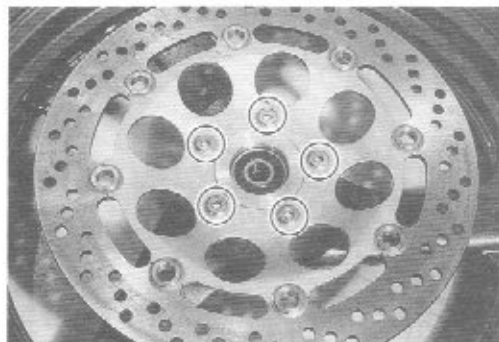

### SPEEDOMETER GEARBOX

- Grease the teeth of speedometer gear before installing speedometer gearbox.
- Aligning the drive lugs ① to recesses ② on the wheel hub, fit the speedometer gearbox on the wheel hub.

99000-25010: SUZUKI SUPER GREASE "A"

#### CAUTION:

After touching the speedometer gear box ③ to the stopper ④, tighten the axle nut.

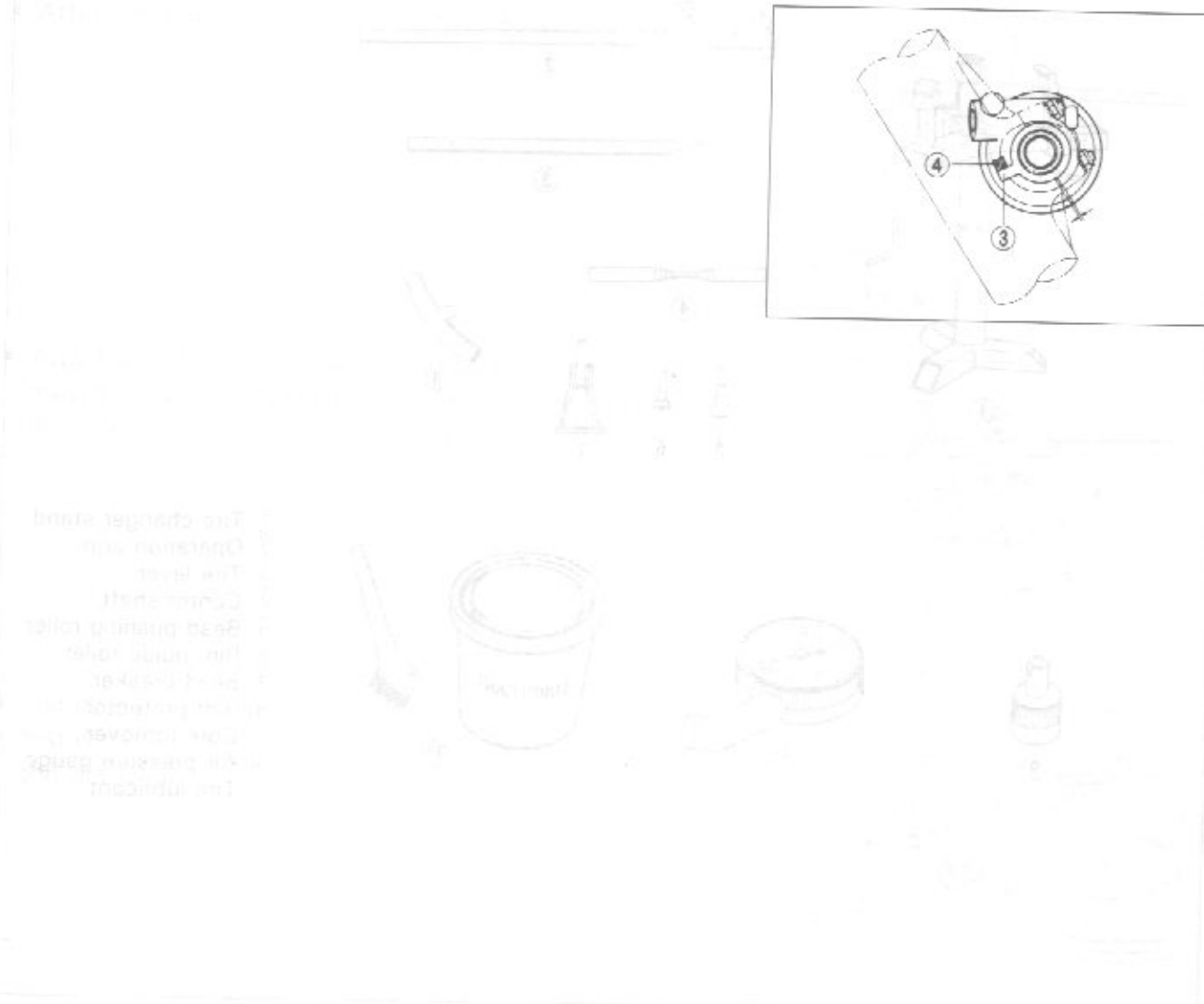
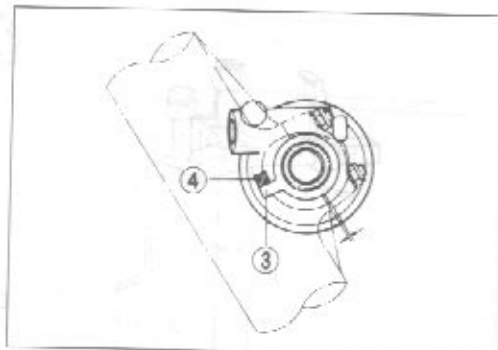
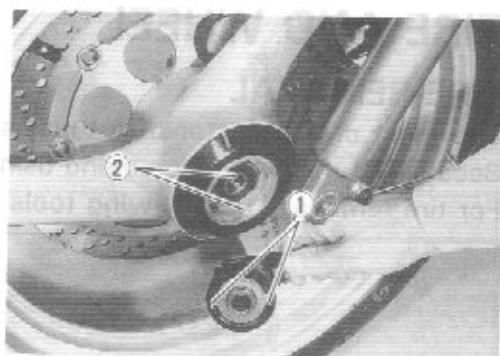

The original stand  
 Grease  
 The hub  
 Conical shaft  
 Gear driving roller  
 The main roller  
 The roller  
 The protector  
 The roller  
 The roller  
 The roller

NOTE: Mark the tire with ink to rotate the wheel of the tire on the rim and rotational direction of the tire.  
 Remove the valve from the tire stem, and deflate the tire completely.



## TIRE AND WHEEL

### TIRE REMOVAL

The most critical factor of a tubeless tire is the seal between the wheel rim and the tire bead. Because of this, we recommend using a tire changer which is also more efficient than tire levers. For tire removal, the following tools are required.

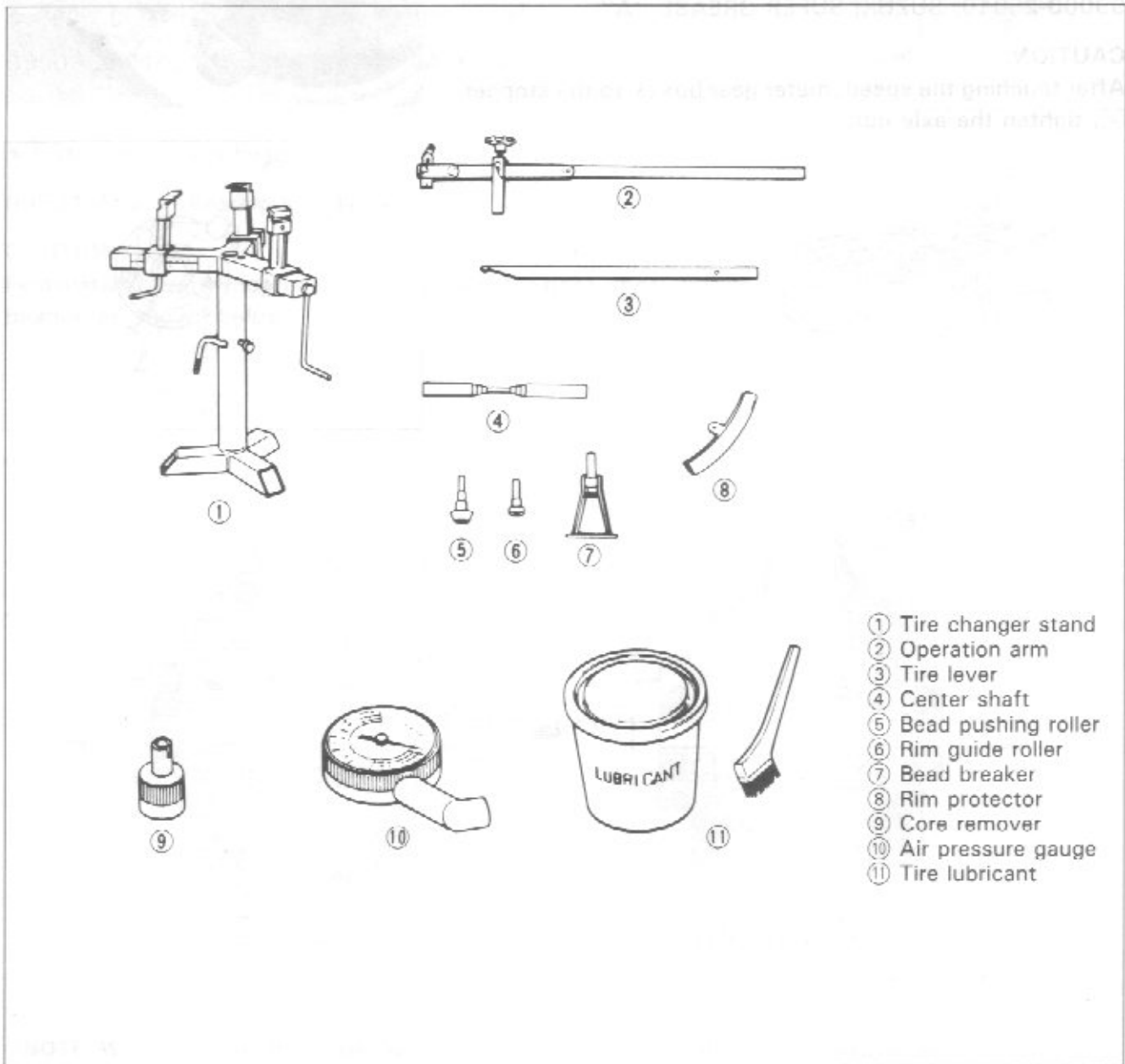

- Remove the valve core from the valve stem, and deflate the tire completely.

#### NOTE:

Mark the tire with chalk to note the position ① of the tire on the rim and rotational direction ② of the tire.

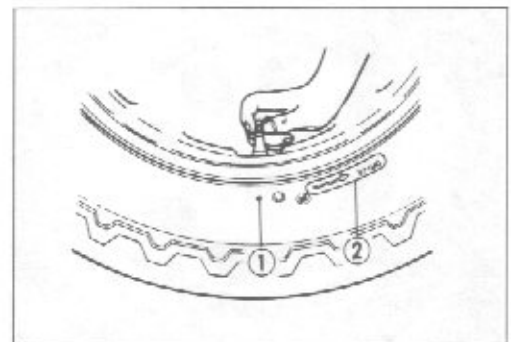

- Place the center shaft (1) to the wheel, and fix the wheel with the rim holder (2).

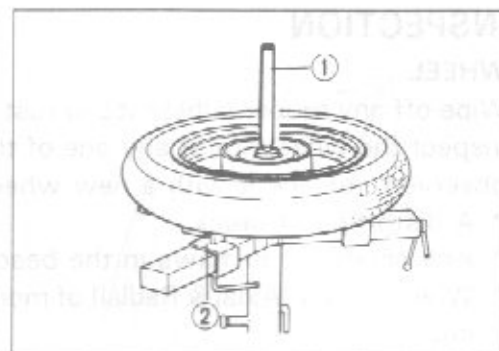

- Attach the operation arm (3) to the center shaft.

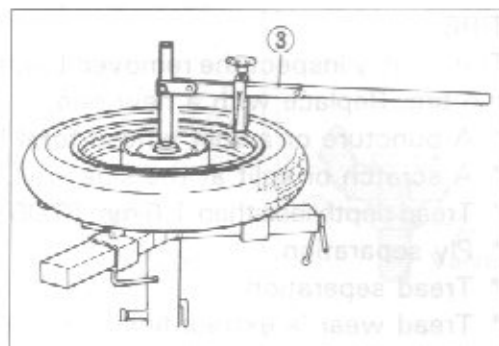

- Attach the bead breaker (4) to the operation arm, and dismount the bead from the rim. Turn the wheel over and dismount the other bead from the rim.

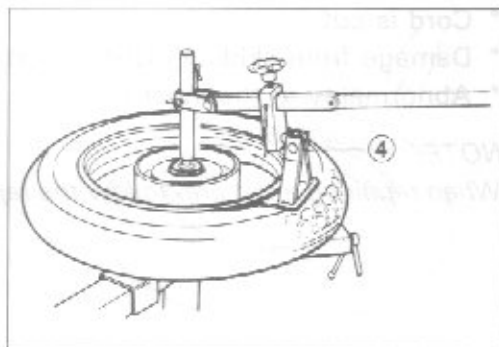
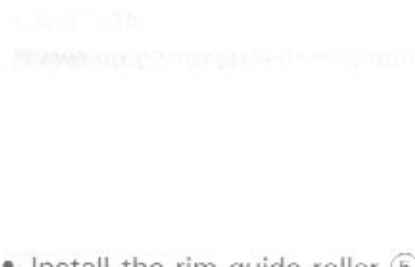

- Install the rim guide roller (5).
- Install the rim protector (6), and raise the tire bead with the tire lever (7).

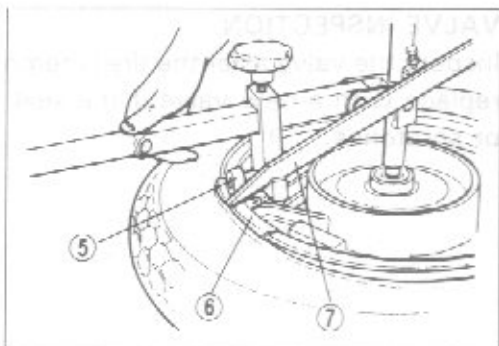

- Set the tire lever against the operation arm, and rotate the lever around the rim. Repeat this procedure to remove the other bead from the rim.

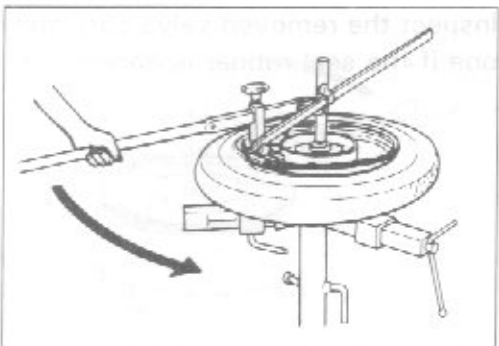

## INSPECTION

### WHEEL

Wipe off any rubber substance or rust from the wheel, and inspect the wheel rim. If any one of the following items is observed, replace it with a new wheel.

- \* A distortion or crack.
- \* Any scratches or flaws in the bead seating area.
- \* Wheel runout (Axial & Radial) of more than 2.0 mm (0.08 in).

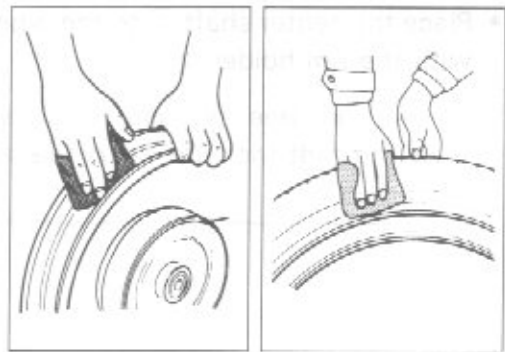

### TIRE

Thoroughly inspect the removed tire, and if any one of the following items is observed, do not repair the tire. Replace with a new one.

- \* A puncture or a split whose total length or diameter exceeds 6.0 mm (0.24 in).
- \* A scratch or split at the side wall.
- \* Tread depth less than 1.6 mm (0.06 in) in the front tire and less than 2.0 mm (0.08 in) in the rear tire.
- \* Ply separation.
- \* Tread separation.
- \* Tread wear is extraordinarily deformed or distributed around the tire.
- \* Scratches at the bead.
- \* Cord is cut.
- \* Damage from skidding (flat spots).
- \* Abnormality in the inner liner.

#### NOTE:

When repairing a flat tire, follow the repair instructions and use only recommended repairing materials.

### VALVE INSPECTION

Inspect the valve after the tire is removed from the rim, and replace with a new valve if the seal rubber has any splits or scratches.

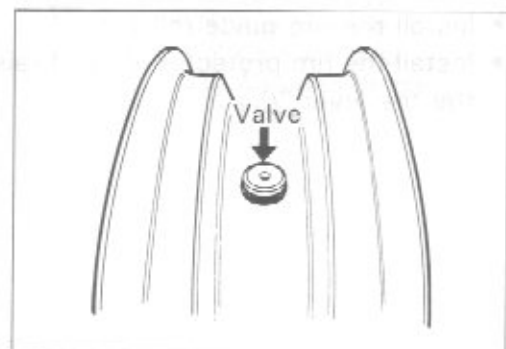

Inspect the removed valve core and replace with the new one if the seal rubber is abnormally deformed or worn.

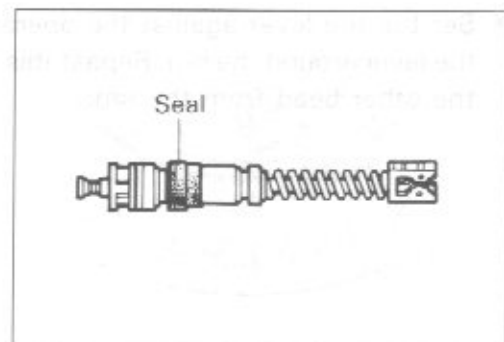

## VALVE INSTALLATION

Any dust or rust around the valve hole must be cleaned off. Then install the valve in the rim.

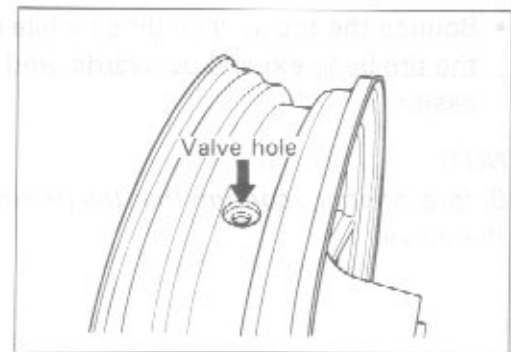

### CAUTION:

When installing the valve, tighten the nut ① by hand as much as possible. Holding the nut ① under this condition, tighten the lock nut ②. Do not overtighten the nut ① as this may distort the rubber packing and cause an air leak.

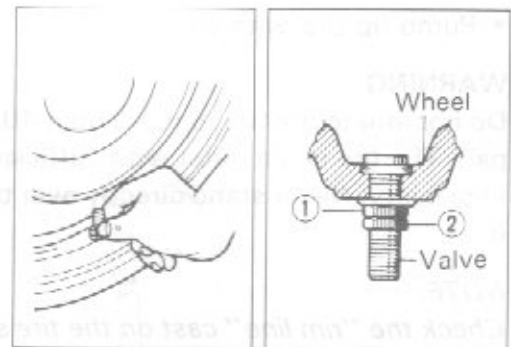

## TIRE MOUNTING

- Apply a special tire lubricant or neutral soapy liquid to the tire bead.

### CAUTION:

Never apply grease, oil or gasoline to the tire bead.

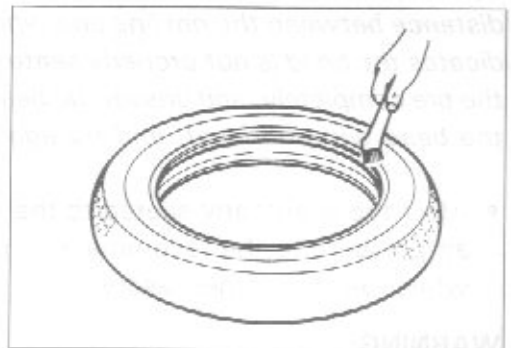

- When installing the tire, make certain that the directional arrow faces the direction of wheel rotation and align the balancing mark of the tire with the valve as shown.

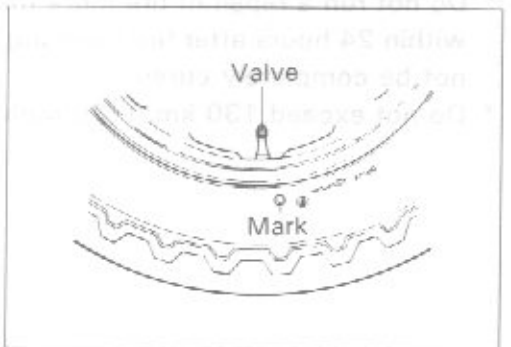

- Set the bead pushing roller ③.
- Rotate the operation arm around the rim to mount the bead completely. Do the bottom bead first, then the upper bead.
- Remove the wheel from the tire changer, and install the valve core in the valve stem.

### NOTE:

Before installing the valve core, inspect the core.

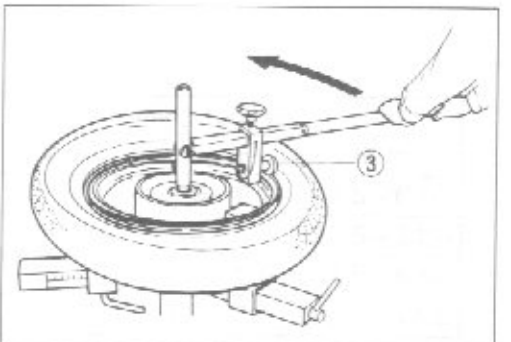



- Bounce the tire several times while rotating. This makes the tire bead expand outwards, and thus makes inflation easier.

**NOTE:**

Before inflating, confirm that the balance mark lines up with the valve.

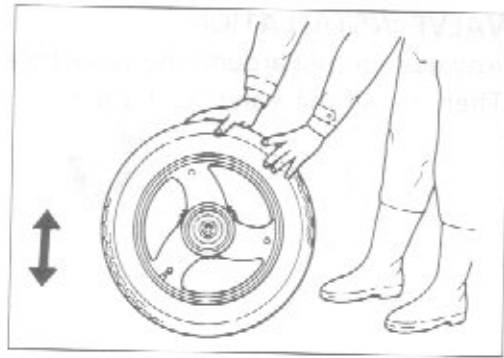

- Pump up tire with air.

**WARNING:**

Do not inflate the tire to more than 40 kPa (4.0 kg/cm<sup>2</sup>, 56 psi). The tire could burst with sufficient force to cause severe injury. Never stand directly over the tire while inflating it.

**NOTE:**

Check the "rim line" cast on the tire side walls. It must be equidistant from the wheel rim all the way around. If the distance between the rim line and wheel rim varies, this indicates the bead is not properly seated. If this is so, deflate the tire completely, and unseat the bead for both sides. Coat the bead with lubricant, and try again.

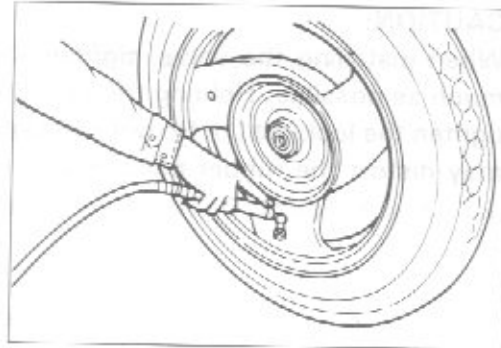

- After tire is properly seated to the wheel rim, adjust the air-pressure to the recommended pressure. Correct the wheel balance if necessary.

**WARNING:**

- \* Do not run a repaired tire more than 50 km/h (30 mph) within 24 hours after tire repairing, since the patch may not be completely cured.
- \* Do not exceed 130 km/h (80 mph) with a repaired tire.

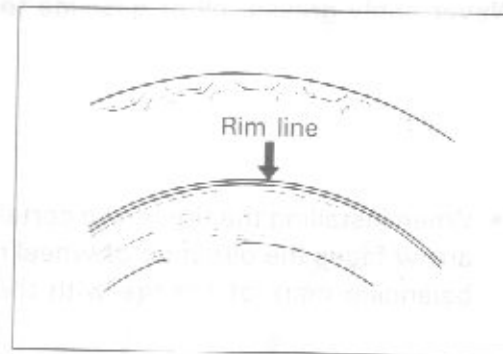

## FRONT BRAKE

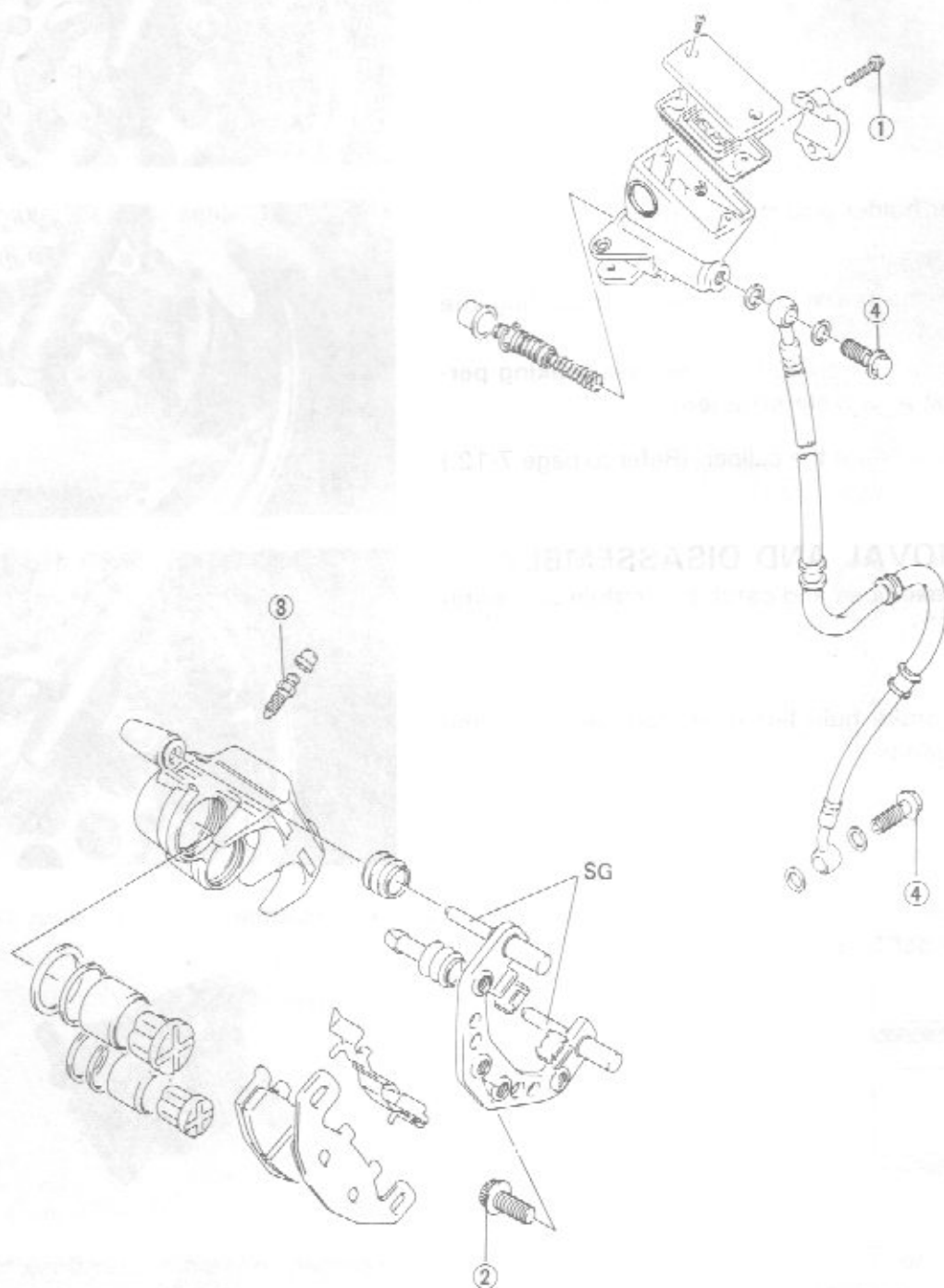

SG: Apply SUZUKI SILICONE GREASE  
(99000-25100)

ITEM	Tightening torque		
	N·m	kg·m	lb·ft
①	5-8	0.5-0.8	3.5-6.0
②	30-47	3.4-4.7	21.5-34.0
③	6-9	0.6-0.9	4.5-6.5
④	15-20	1.5-2.0	11.0-14.5

## BRAKE PAD REPLACEMENT

- Remove the brake caliper by removing its mounting bolts.

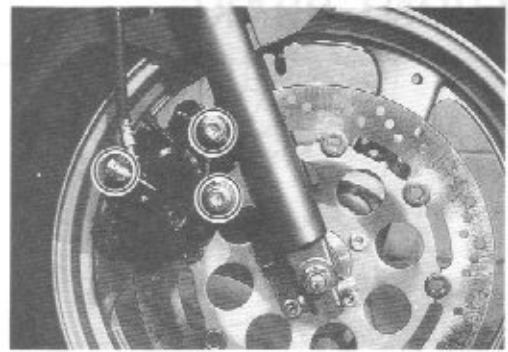

- Push the caliper holder and then remove the pads.

### CAUTION:

- \* Do not operate the brake lever while dismantling the pads.
- \* Replace the brake pad as a set, otherwise braking performance will be adversely affected.

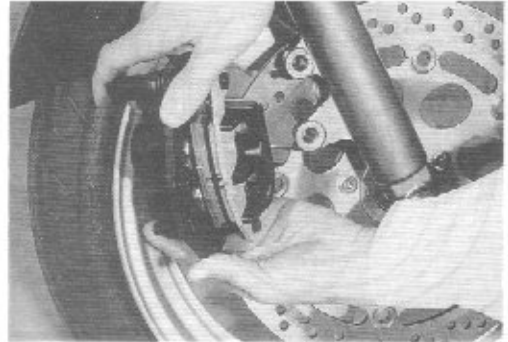

- Reassemble and remount the caliper. (Refer to page 7-12.)

## CALIPER REMOVAL AND DISASSEMBLY

Disconnect the brake hose and catch brake fluid in a suitable receptacle.

### CAUTION:

Never re-use the brake fluid left over from servicing and stored for long periods.

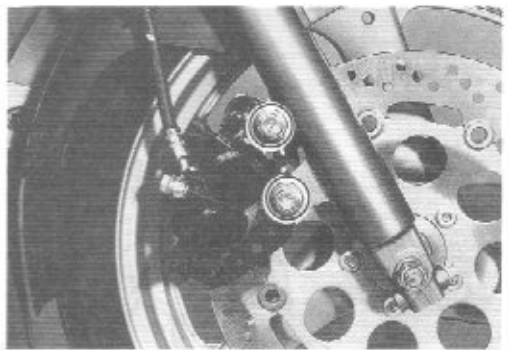

- Remove the pads.
- Remove the caliper holder ①.

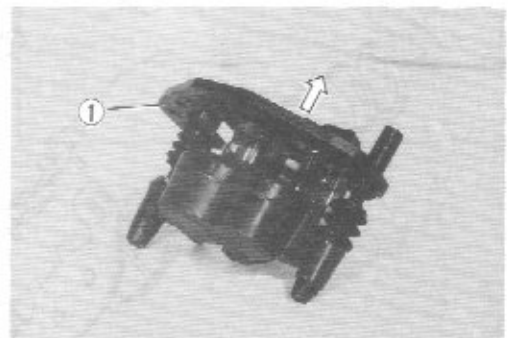

- Remove the spring ②.
- Remove the insulators ③.

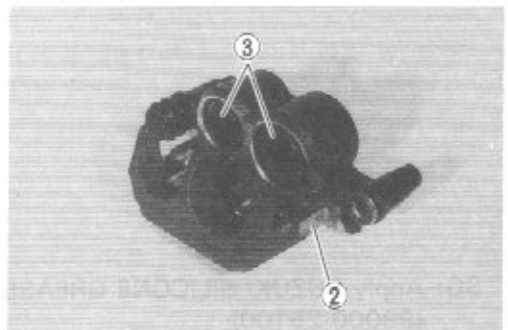

Part No.	QTY	Part No.	QTY
08-20	1	08-20	1
08-21	1	08-21	1
08-22	1	08-22	1
08-23	1	08-23	1
08-24	1	08-24	1
08-25	1	08-25	1

- Place a rag over the piston to prevent popping up. Force out the pistons with an air gun.

**CAUTION:**

Do not use high pressure air to prevent piston damage.

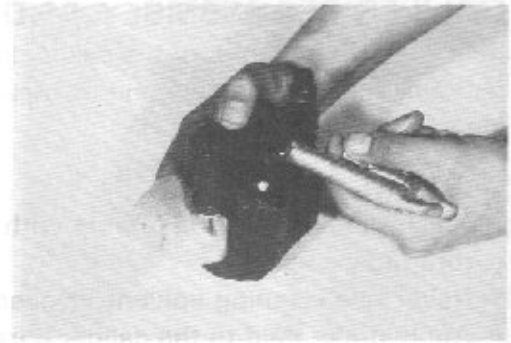

- Remove the dust seals (1) and piston seals (2).

**CALIPER AND DISC INSPECTION**

Inspect the caliper cylinder bore wall for nicks, scratches or other damage.

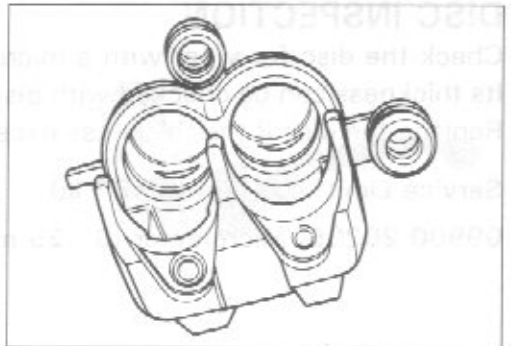

Inspect each piston for damage and wear.

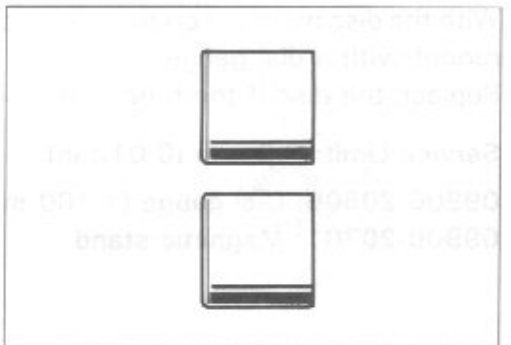

Inspect each rubber part for damage and wear.

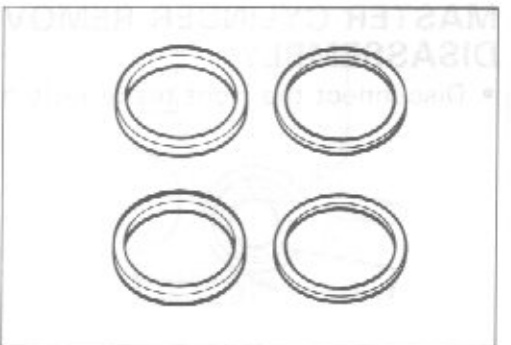

## CALIPER REASSEMBLY AND REMOUNTING

Reassemble and remount the caliper in the reverse order of removal and disassembly and also carry out the following steps:

### CAUTION:

- \* Wash the caliper components with fresh brake fluid before reassembly.
- \* Never use cleaning solvent or gasoline to wash them.
- \* Apply brake fluid to the caliper bore and piston to be inserted into the bore.

- Reassemble and remount the caliper. (Refer to page 7-12.)

### WARNING:

Bleed air after reassembling the caliper. (Refer to page 2-15.)

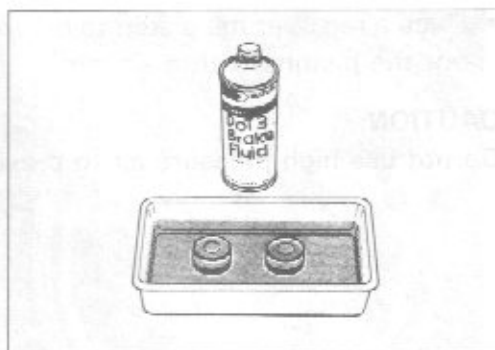

## DISC INSPECTION

Check the disc for wear with a micrometer. Its thickness can be checked with disc and wheel in place. Replace the disc if the thickness exceeds the service limit.

**Service Limit: 4.0 mm (0.157 in)**

09900-20205: Micrometer (0–25 mm)

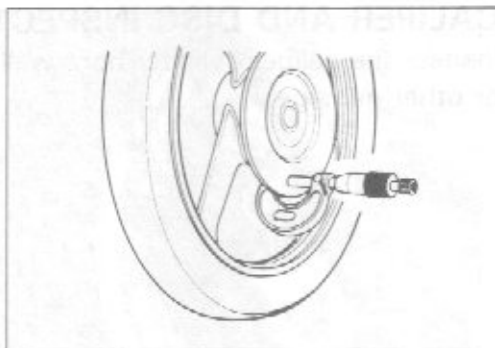

With the disc mounted on the wheel, check the disc for face runout with a dial gauge.

Replace the disc if the runout exceeds the service limit.

**Service Limit: 0.3 mm (0.012 in)**

09900-20606: Dial gauge (1/100 mm)

09900-20701: Magnetic stand

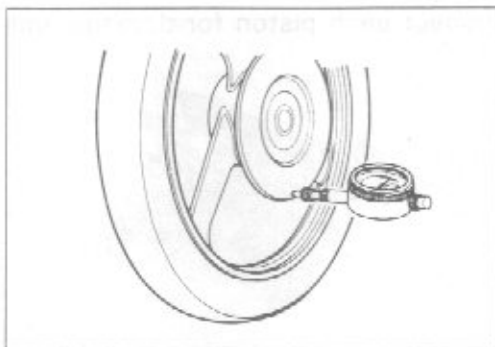

## MASTER CYLINDER REMOVAL AND DISASSEMBLY

- Disconnect the front brake switch lead wires.



- Place a cloth underneath the union bolt on the master cylinder to catch spilled drops of brake fluid. Unscrew the union bolt and disconnect the brake hose/master cylinder joint.

**CAUTION:**

Completely wipe off any brake fluid adhering to any part of motorcycle. The fluid reacts chemically with paint, plastics, rubber materials, etc.

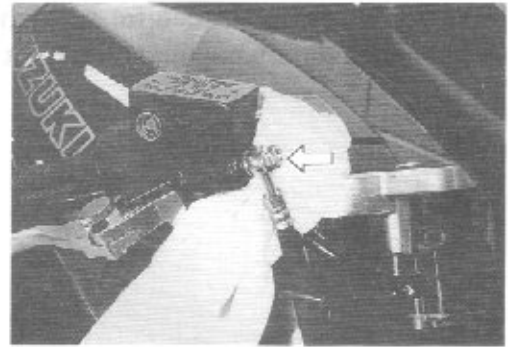

- Remove the master cylinder.



- Remove the brake lever and brake switch.
- Remove the reservoir cap and diaphragm.
- Drain brake fluid.

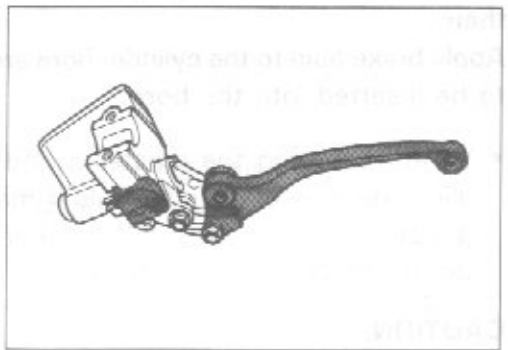

- Remove the dust boot.
- Remove the circlip with the special tool.

**09900-06108: Snap ring pliers**

- Remove the piston/primary cup with return spring.

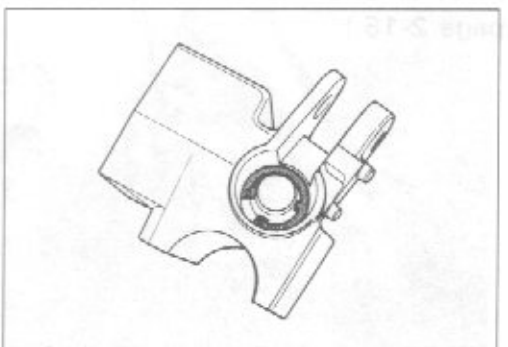
**MASTER CYLINDER INSPECTION**

Inspect the master cylinder bore for any scratches or other damage.

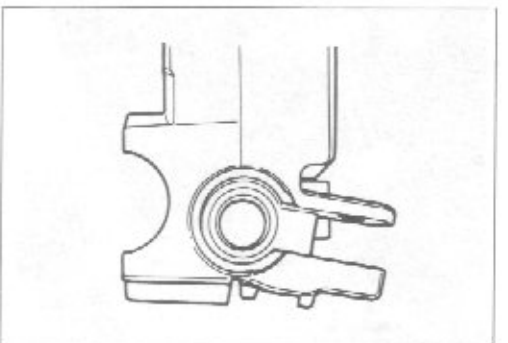

Inspect the piston surface for scratches or other damage.  
Inspect the primary cup and dust boot for wear or damage.

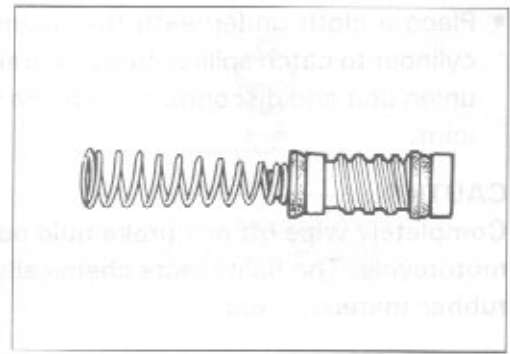

## MASTER CYLINDER REASSEMBLY AND REMOUNTING

Reassemble and remount the master cylinder in the reverse order of removal and disassembly, and also carry out the following steps:

**99000-23110: SUZUKI BRAKE FLUID DOT 3 & 4**

### CAUTION:

Wash the master cylinder components with fresh brake fluid before reassembly. Never use solvent or gasoline to wash them.

Apply brake fluid to the cylinder bore and all the internal parts to be inserted into the bore.

- When mounting the master cylinder on the handlebar, align the master cylinder holder mating surface ① with punched mark ② on the handlebar, and tighten the upper clamp bolt first as shown.



### CAUTION:

Bleed air after reassembling the master cylinder. (Refer to page 2-15.)

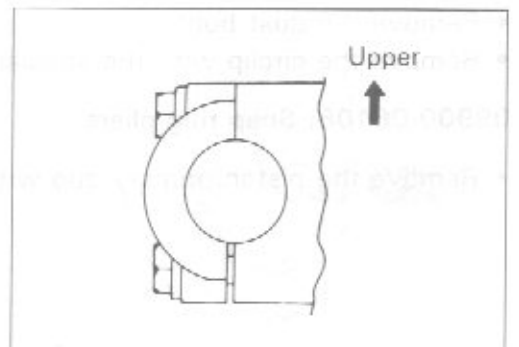

MASTER CYLINDER  
DISASSEMBLY



## FRONT FORK

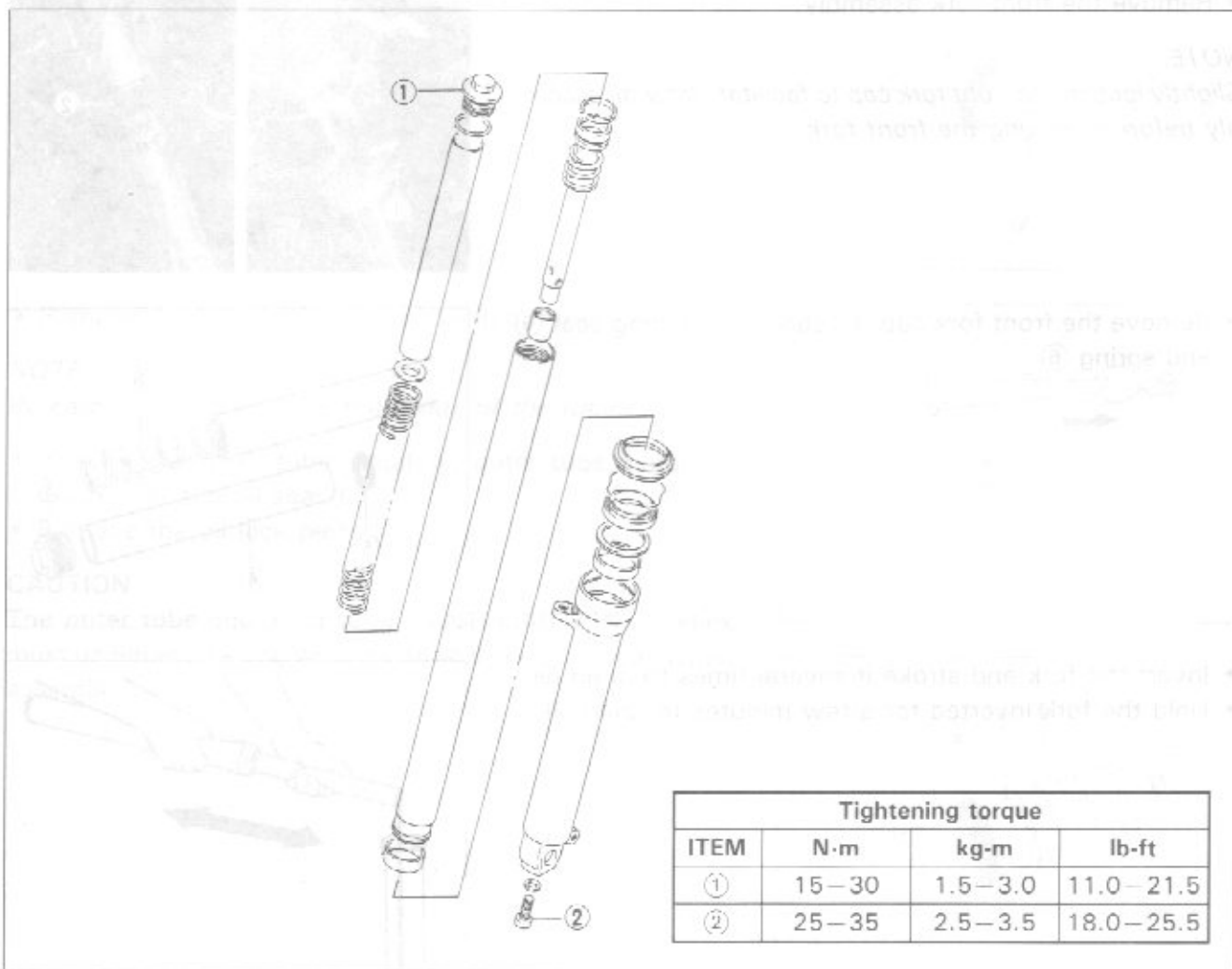

### REMOVAL AND DISASSEMBLY

- Remove the front wheel. (Refer to page 7-3.)
- Remove the brake caliper and hose guide.

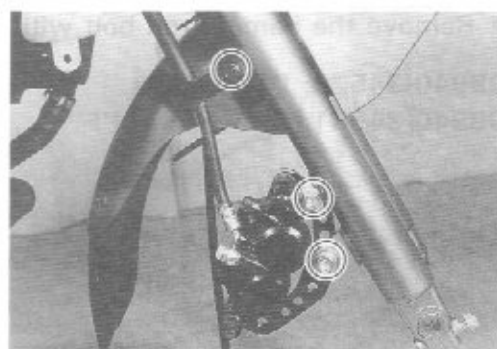

- Remove the front fender and fender brace.

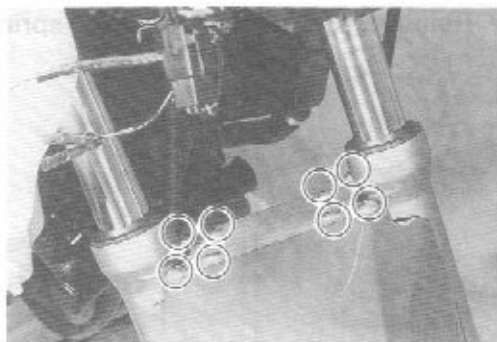



- Loosen the front fork upper and lower clamp bolts (①, ②).
- Remove the front fork assembly.

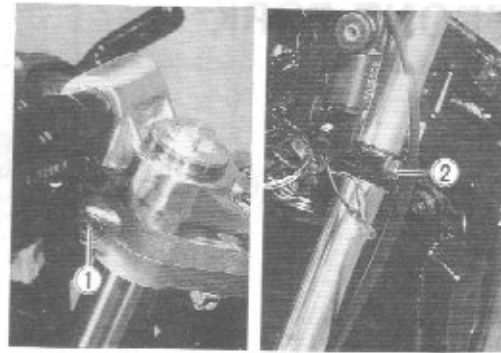

**NOTE:**

*Slightly loosen the front fork cap to facilitate later disassembly before removing the front fork.*

- Remove the front fork cap (③), spacer (④), spring seat (⑤) and spring (⑥).

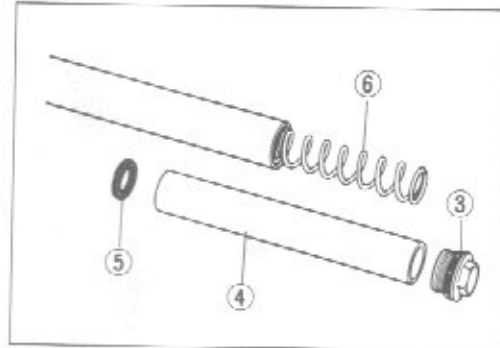

- Invert the fork and stroke it several times to drain oil.
- Hold the fork inverted for a few minutes to drain oil.

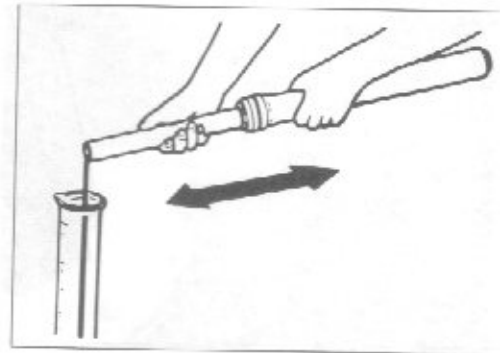

- Remove the damper rod bolt with the special tool.

09940-34520: "T" handle  
 09940-34581: Attachment "F"

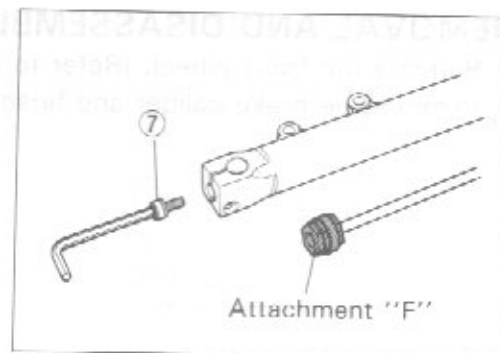

- Remove the damper rod with spring.

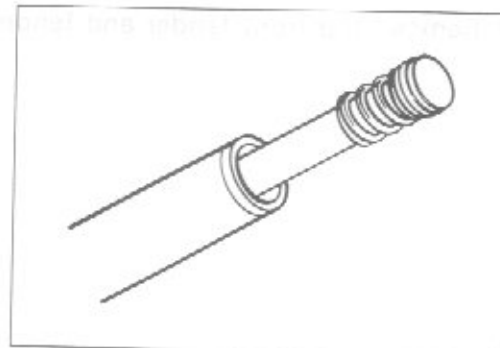

- Remove the dust seal (1) and oil seal stopper ring (2).

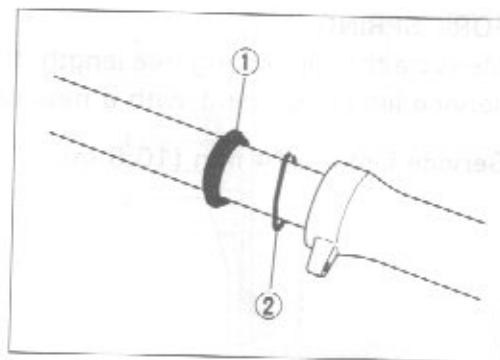

- Remove the oil seal by slowly pulling out the inner tube.

**NOTE:**

*Be careful not to damage the inside of the tube.*

- Remove the inner tube metal (3), outer tube metal (4), washer (5) and oil seal (6).
- Remove the oil lock piece (7).

**CAUTION:**

The outer tube and inner tube "ANTI-FRICTION" metals must be replaced along with the oil seal and dust seal, when assembling front fork.

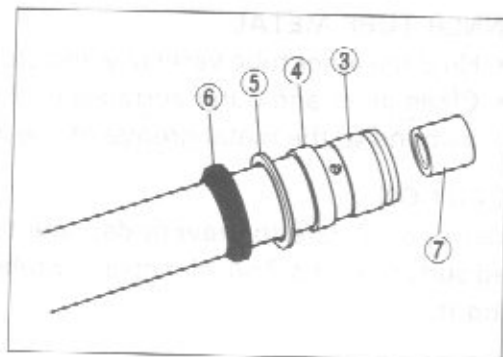
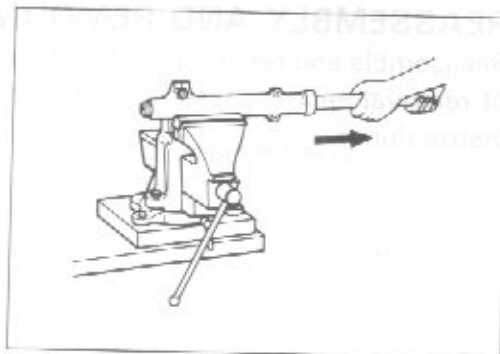
**INSPECTION****DAMPER ROD RING**

Inspect the damper rod ring for wear and damage.

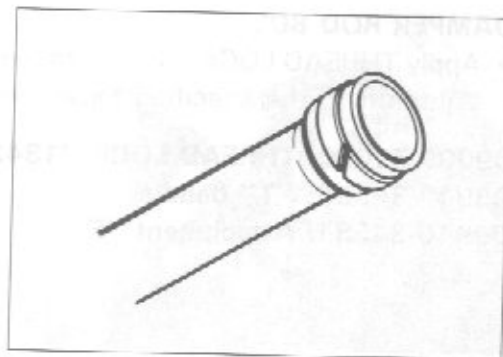
**INNER AND OUTER TUBE**

Inspect the inner tube sliding surface and outer tube sliding surface for any scuffing.

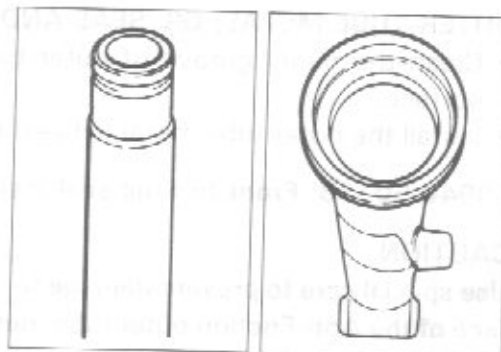

**FORK SPRING**

Measure the fork spring free length. If it is shorter than the service limit, replace it with a new one.

**Service Limit: 274 mm (10.8 in)**

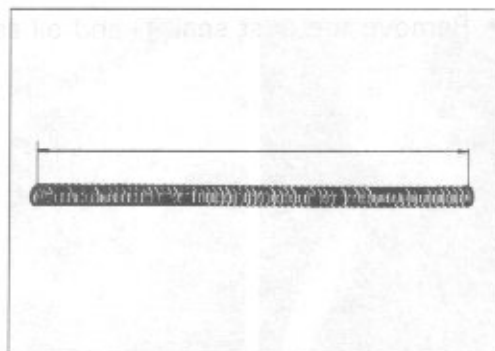
**REASSEMBLY AND REMOUNTING**

Reassemble and remount the front fork in the reverse order of removal and disassembly. Also observe the following instructions:

**INNER TUBE METAL**

- Hold the inner tube vertically and clean the metal groove.
- Clean inner and outer surfaces of the metal and install it by hand to the metal groove of the inner tube as shown.

**CAUTION:**

Use special care to prevent damage to the "Teflon" coated surface of the Anti-friction inner tube metal when mounting it.

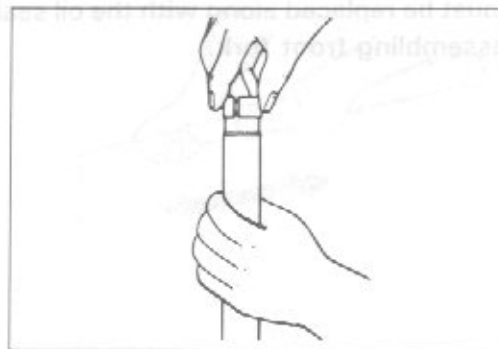
**DAMPER ROD BOLT**

- Apply THREAD LOCK "1342" to the damper rod bolt and tighten it to the specified torque with the special tool.

**99000-32050: THREAD LOCK "1342"**

**09940-34520: "T" handle**

**09940-34581: Attachment "F"**

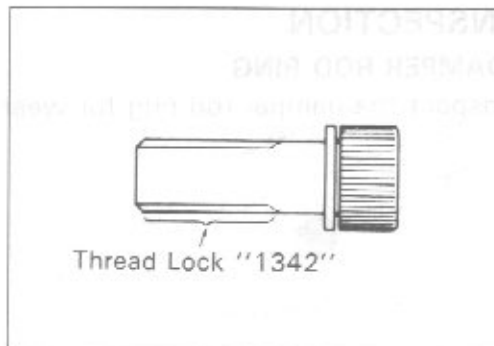
**OUTER TUBE METAL, OIL SEAL AND DUST SEAL**

- Clean the metal groove of outer tube and metal outer surface.
- Install the outer tube metal, oil seal retainer and oil seal.

**09940-50113: Front fork oil seal installer**

**CAUTION:**

Use special care to prevent damage to "Teflon" coated surface of the Anti-Friction outer tube metal when installing it.

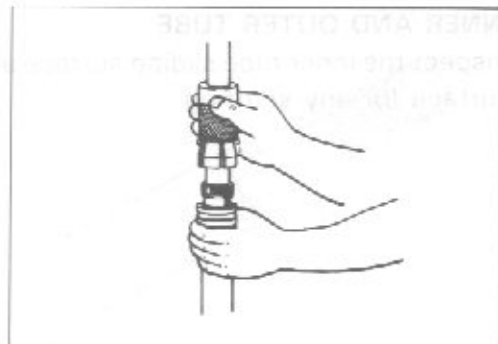

- After installing the oil seal, install the oil seal stopper ring and dust seal.
  - ① Anti-friction metal
  - ② Oil seal retainer
  - ③ Oil seal
  - ④ Oil seal stopper ring
  - ⑤ Dust seal

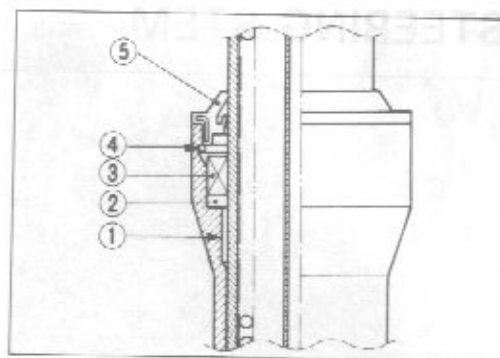

### FORK OIL

- Use front fork oil whose viscosity rating meets specifications below.

Fork oil type: Fork oil # 10

Fork oil capacity: 401 ml (13.6/14.1 US/Imp oz)

(each leg)

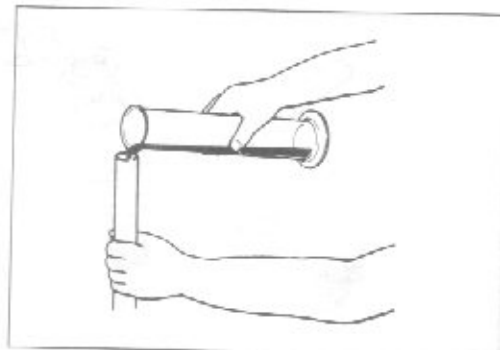

- Hold the front fork vertical and adjust fork oil level with the special tool.

#### NOTE:

When adjusting fork oil level, remove the fork spring and compress the inner tube fully.

Fork oil level: 90 mm (3.5 in)

09943-74111: Fork oil level gauge

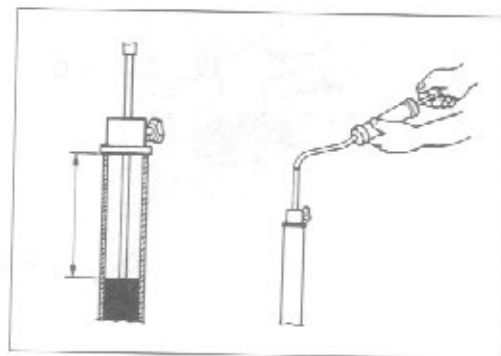

- When remounting the front fork assembly, set the upper surface of the inner tube at 31 mm (1.2 in) height from the upper surface of the steering stem upper bracket.



## STEERING STEM

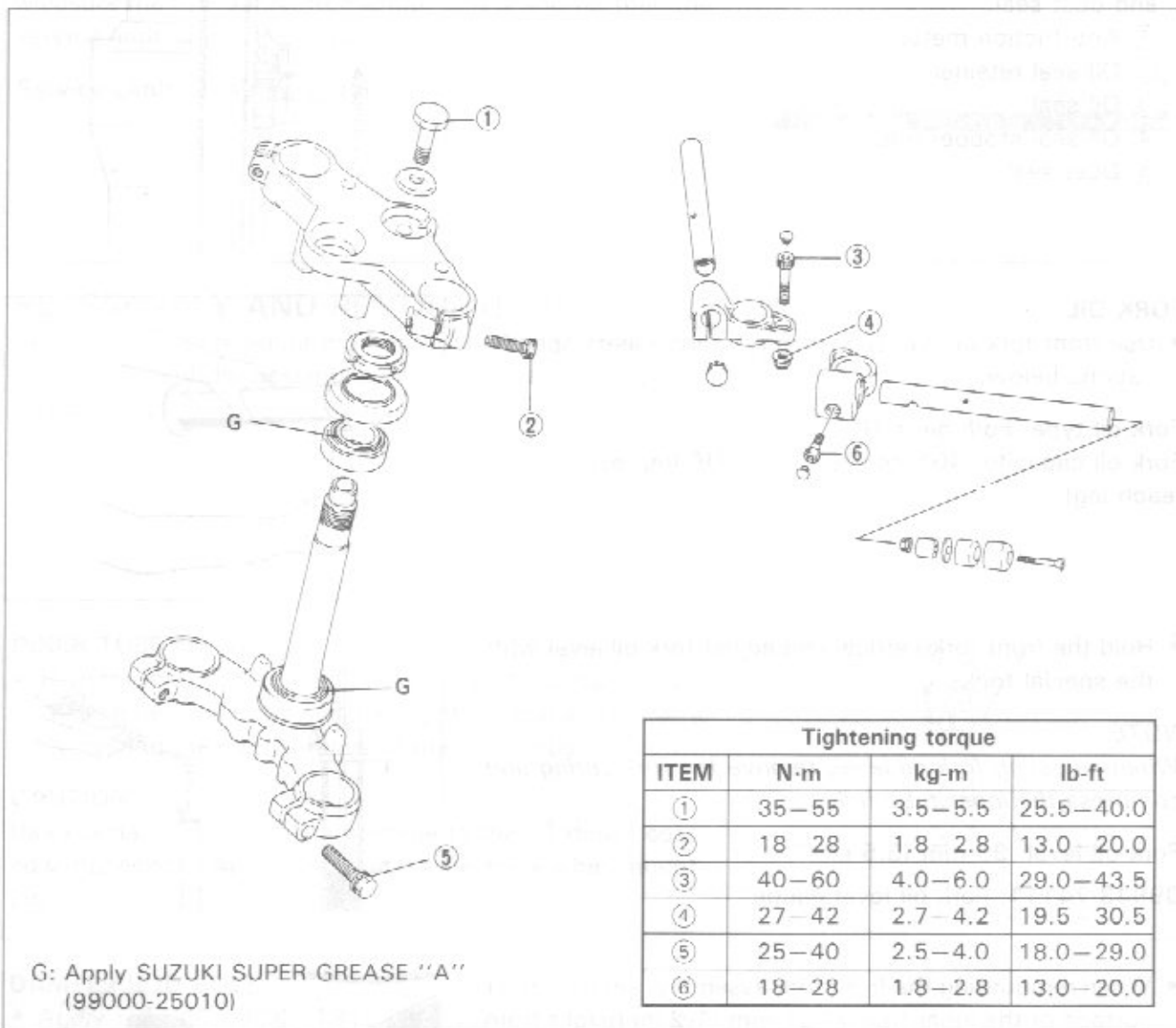

### REMOVAL AND DISASSEMBLY

- Remove the fairing. (Refer to page 7-1.)
- Remove the front wheel. (Refer to page 7-3.)
- Remove the front fork. (Refer to page 7-18.)
- Remove the handlebar holder mounting nuts and bolts.
- Remove the steering stem head bolt.
- Remove the steering stem upper bracket.

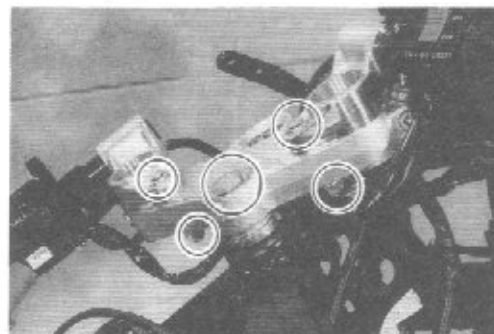

- Remove the brake hose guide and horn.

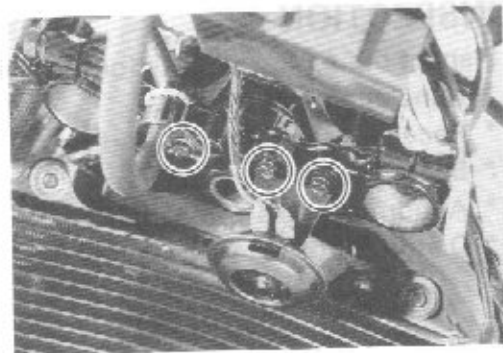

- Remove the steering stem nut with the special tool.

**09940-14911: Steering nut socket wrench**

**NOTE:**

Hold the steering stem lower bracket by hand to prevent it from falling.

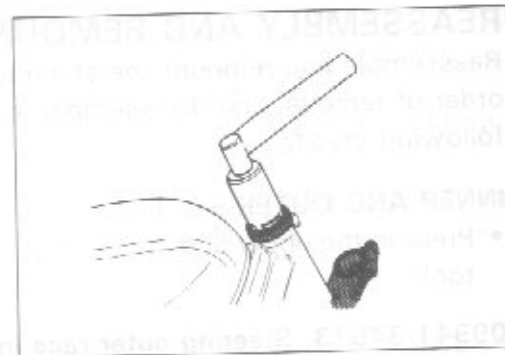

- Remove the dust seal cover and upper bearing.

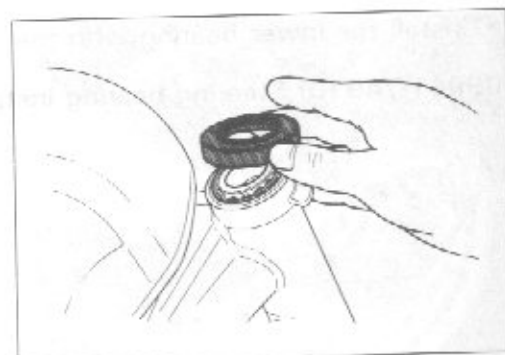
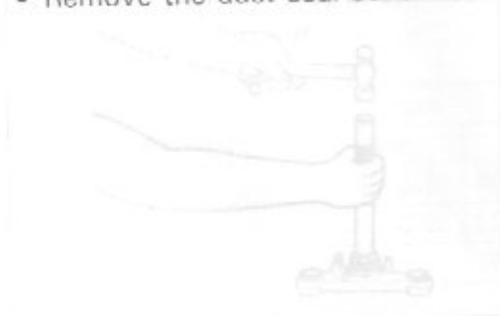

- Remove the steering stem inner bearing races with the special tools.

**09941-54911: Bearing outer race remover**

**09941-74910: Steering bearing installer and remover**

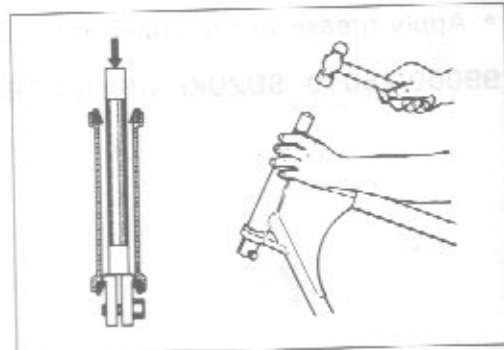

- Remove the lower bearing with the special tool.

**09941-84510: Bearing remover**

**CAUTION:**

The removed bearing should be replaced with a new one.

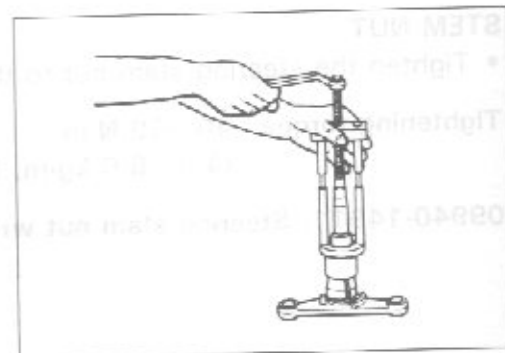

## INSPECTION

Inspect the removed parts for the following abnormalities.

- \* Handlebar distortion
- \* Race wear and brinelling
- \* Bearing wear or damage
- \* Abnormal noise of bearing
- \* Distortion of steering stem

## REASSEMBLY AND REMOUNTING

Reassemble and remount the steering stem in the reverse order of removal and disassembly, and also carry out the following steps:

### INNER AND OUTER RACES

- Press in the upper and lower inner races with the special tool.

**09941-34513: Steering outer race installer**

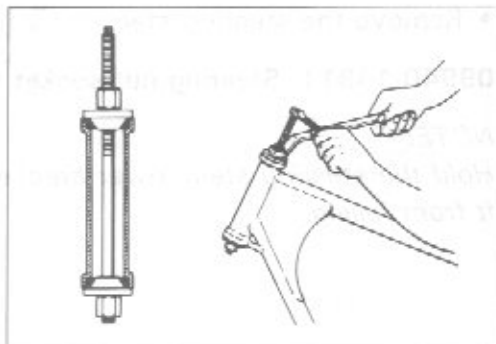

- Install the lower bearing with the special tool.

**09941-74910: Steering bearing installer**

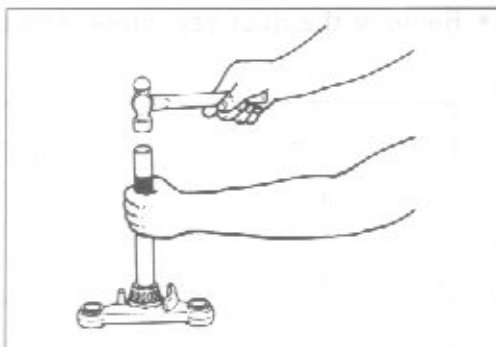

- Apply grease to the upper and lower bearings.

**99000-25010: SUZUKI SUPER GREASE "A"**

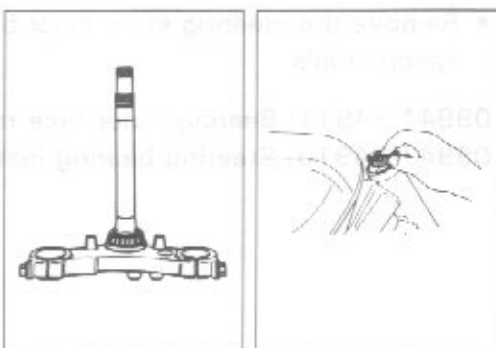

### STEM NUT

- Tighten the steering stem nut to the specified torque.

Tightening torque: 40 – 60 N·m  
(4.0 – 6.0 kg-m, 29.0 – 43.5 lb-ft)

**09940-14911: Steering stem nut wrench**

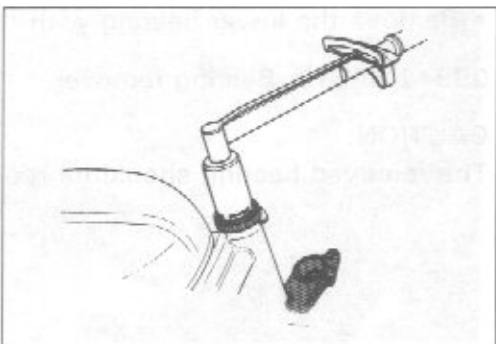

- Turn the steering stem lower bracket about five or six times to the left and right so that the taper roller bearing will be seated properly.

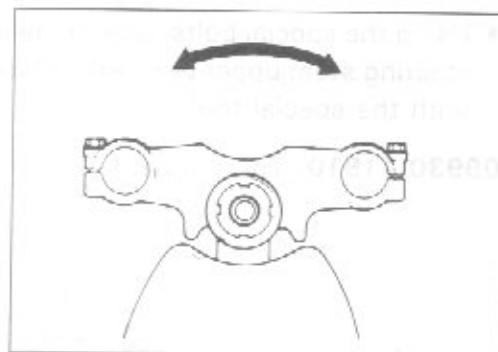

- Turn back the stem nut by 1/4–1/2 turn.

**NOTE:**

*This adjustment will vary from motorcycle to motorcycle.*

**CAUTION:**

After performing the adjustment and installing the steering stem upper bracket, "rock" the front wheel assembly forward and back to ensure that there is no play and that the procedure was accomplished correctly. Finally check to be sure that the steering stem moves freely from left to right with own weight. If play or stiffness is noticeable, re-adjust the steering stem nut.

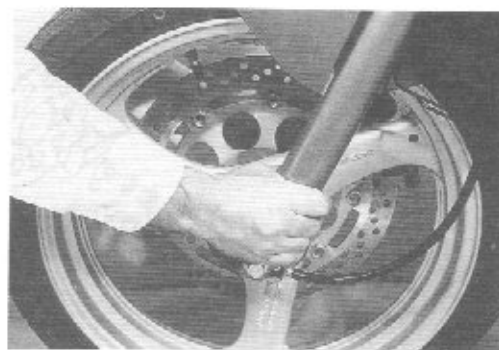
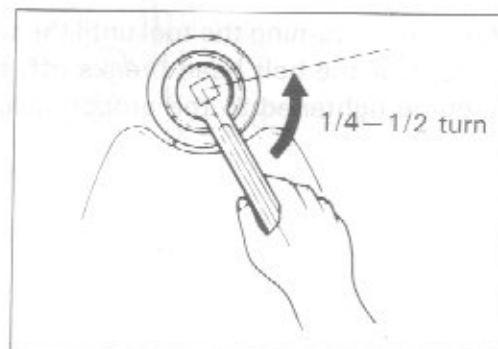

## IGNITION SWITCH

### REMOVAL

- Using a center punch and hammer, remove the bolt to detach the ignition switch from the steering stem upper bracket.

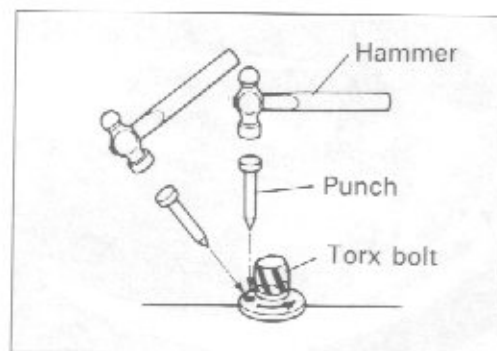

### INSTALLATION

To install the ignition switch, always use the new special bolt and follow the procedures below.

**NOTE:**

*The spare ignition switch comes equipped with the special bolts, however, the bolt is also individually available as spare parts.*



- Using the special bolts, attach the ignition switch on the steering stem upper bracket in place and run in the bolts with the special tool.

**09930-11910: Torx wrench**

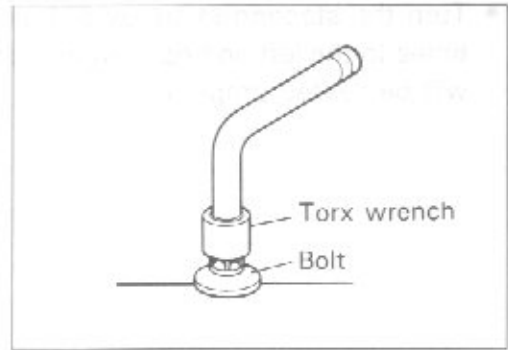

- Continue turning the tool until the tool slips from the bolt head or the bolt head breaks off, then the bolt has become tightened to the proper specification.

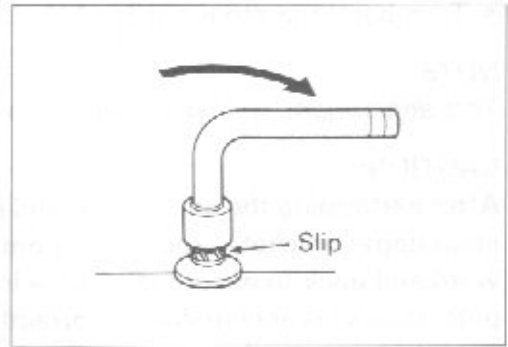

**IGNITION SWITCH  
REMOVAL**

- Remove the ignition switch from the steering stem upper bracket.



## REAR WHEEL

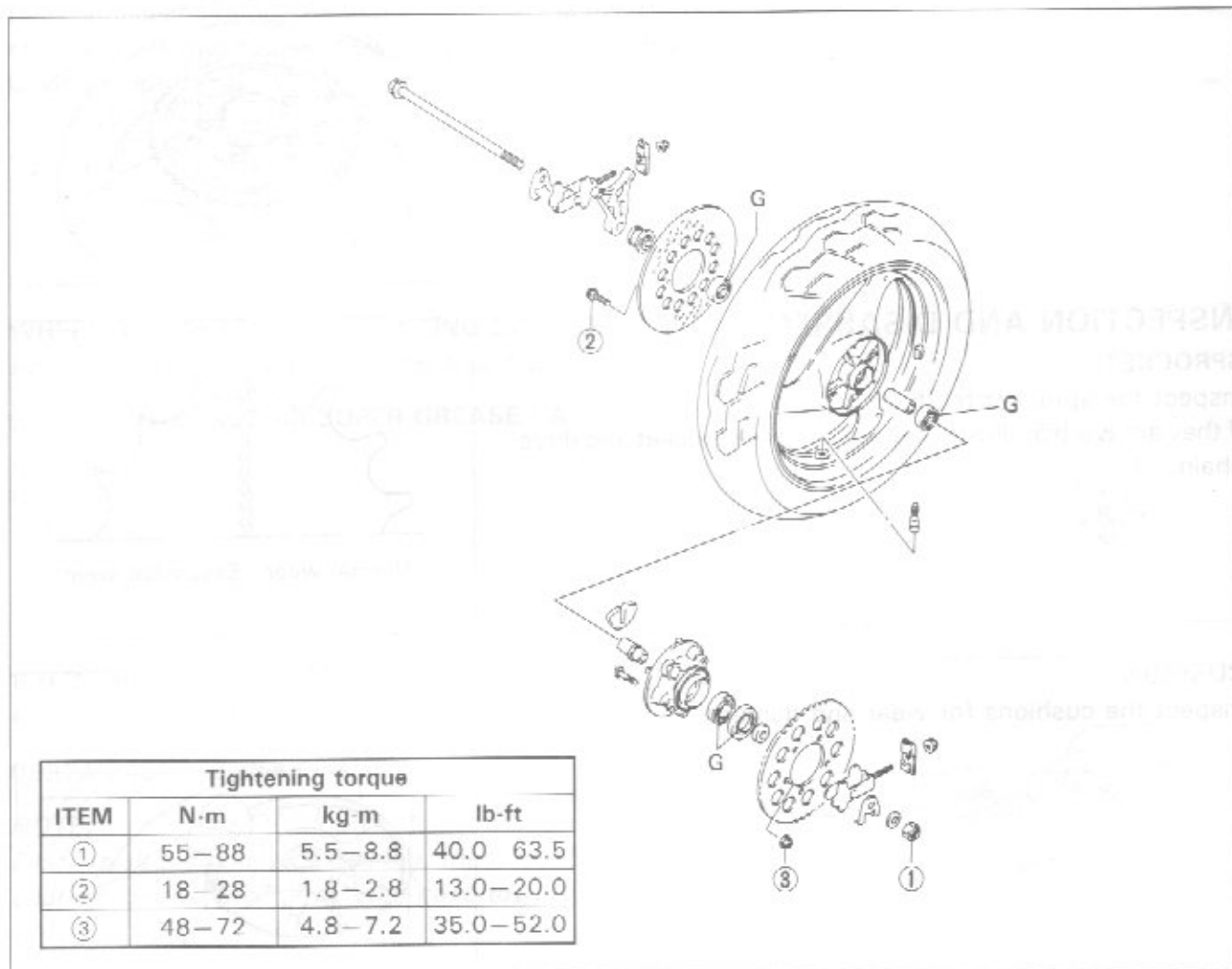

### REMOVAL

- Support the motorcycle with jack or wooden block.
- Remove the rear brake caliper. (Refer to page 7-32.)
- Remove the axle shaft by removing the axle nut.

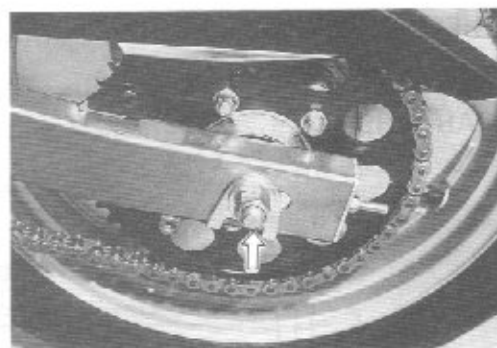

- Remove the rear wheel.



- Remove the rear sprocket mounting drum.

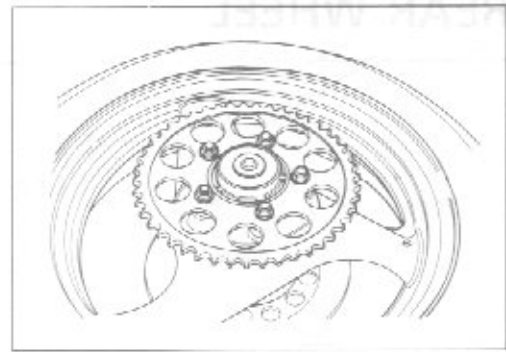

**INSPECTION AND DISASSEMBLY  
SPROCKET**

Inspect the sprocket teeth for wear. If they are worn as illustrated, replace the sprocket and drive chain.

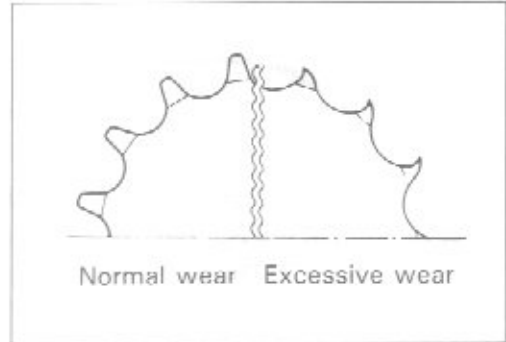

**CUSHION**

Inspect the cushions for wear and damage.

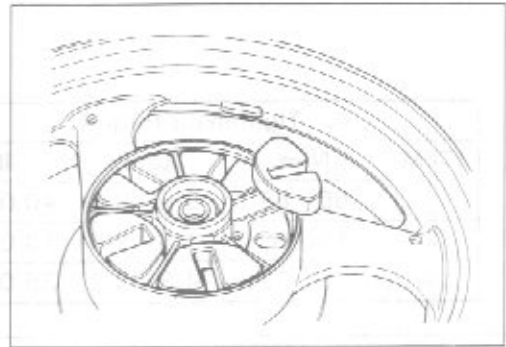

- WHEEL BEARING** ..... Refer to page 7-4.
- AXLE SHAFT** ..... Refer to page 7-4.
- REAR WHEEL** ..... Refer to page 7-4.



## REASSEMBLY AND REMOUNTING

Reassemble and remount the rear wheel in the reverse order of removal and disassembly, and also carry out the following steps:

### WHEEL AND SPROCKET MOUNTING DRUM BEARINGS

Apply grease before installing the bearings.

**99000-25010: SUZUKI SUPER GREASE "A"**



### WHEEL BEARINGS

Install the wheel bearing with the special tool.

**09924-84510: Bearing installer set**

#### NOTE:

*First install the right side bearing, then install the left side bearing. Sealed face of bearing goes toward outside.*

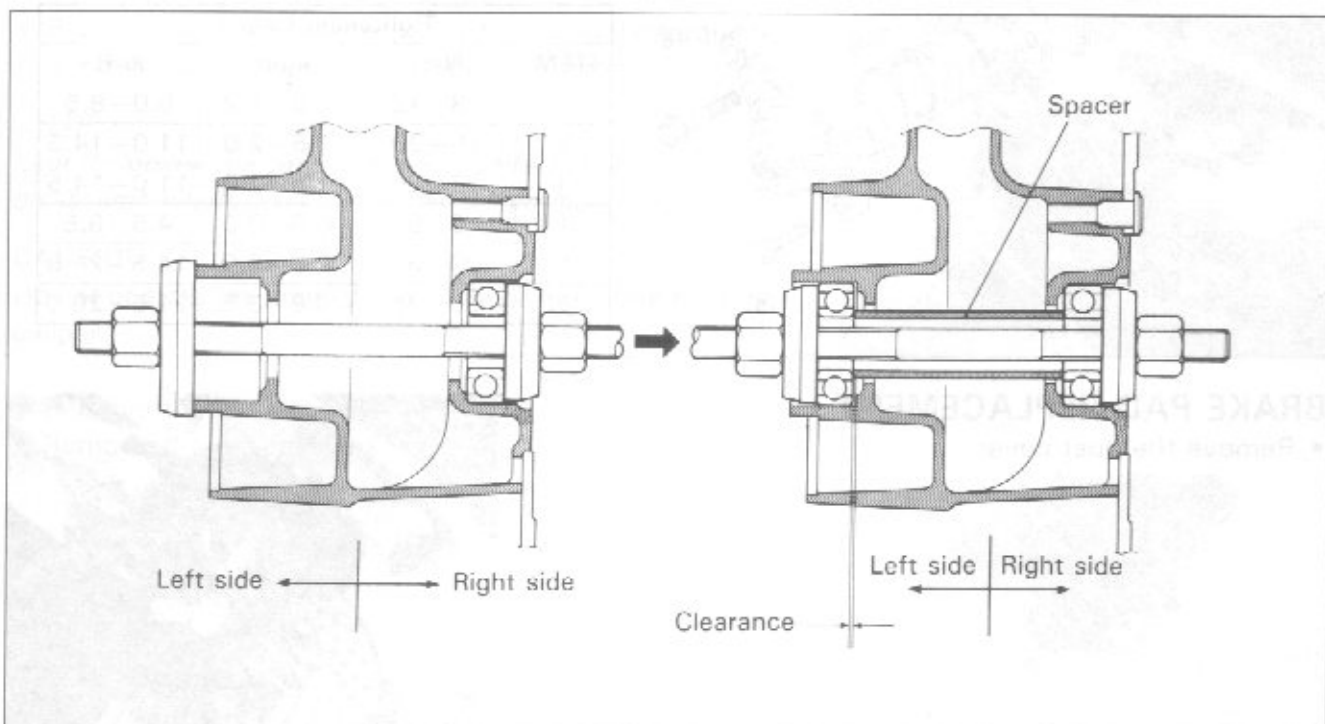
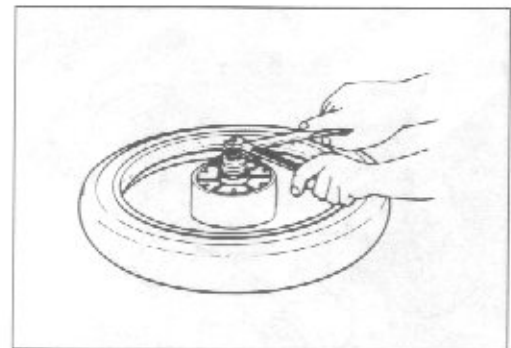

# REAR BRAKE

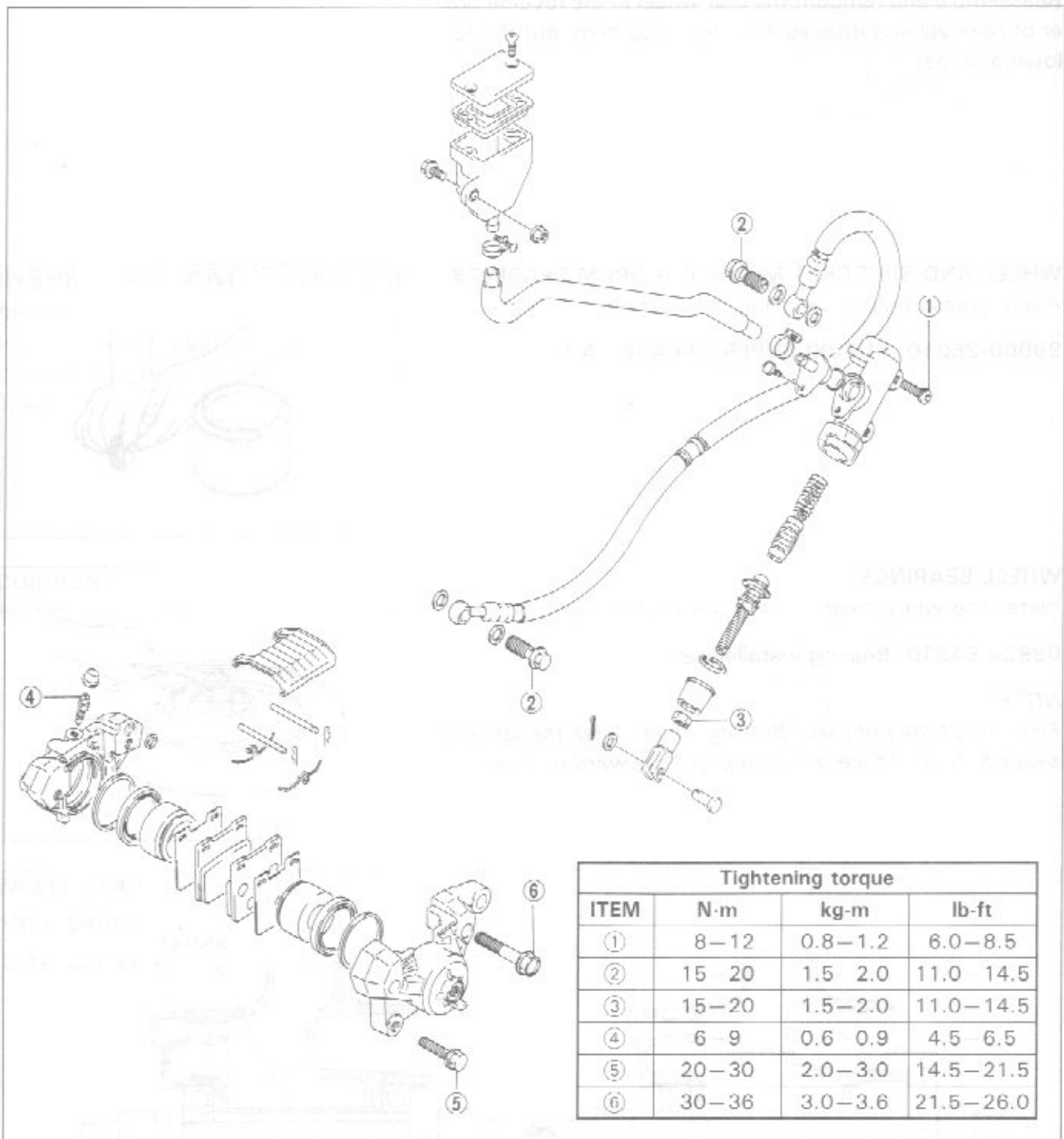

## BRAKE PAD REPLACEMENT

- Remove the dust cover.



- Remove the clips (1) and springs (2), draw out the pins (3).

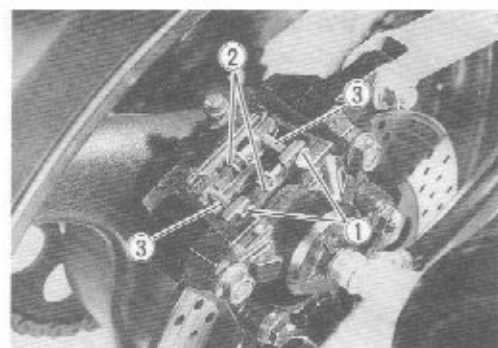

- Remove the pads (4) and shims (5).

**CAUTION:**

- \* Do not operate the brake pedal while dismantling the pads.
- \* Replace the brake pad as a set, otherwise braking performance will be adversely affected.

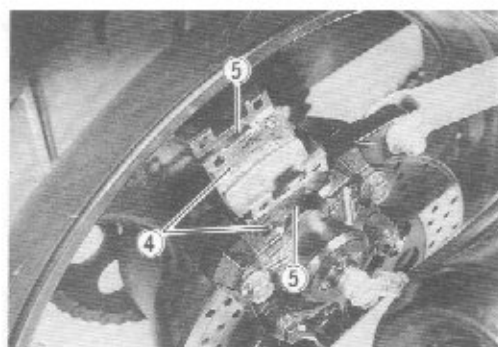

**CALIPER REMOVAL AND DISASSEMBLY**

- Disconnect the brake hose and catch brake fluid in a suitable receptacle.

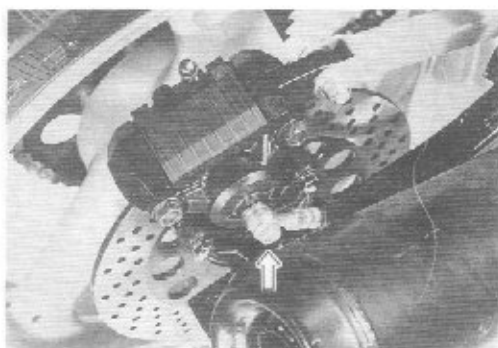

- Remove the rear brake caliper by removing the torque link nut and bolt (6) and caliper mounting bolts (7).

**NOTE:**

*Slightly loosen the caliper housing bolts (8) to facilitate later disassembly before removing the caliper mounting bolts (7).*

**CAUTION:**

**Do not operate the brake pedal while dismantling the brake caliper.**

- Remove the brake pads.
- Remove the caliper housing bolts.

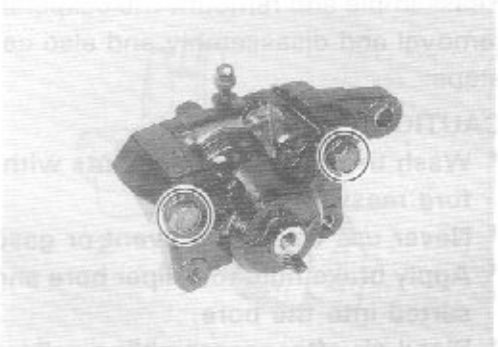
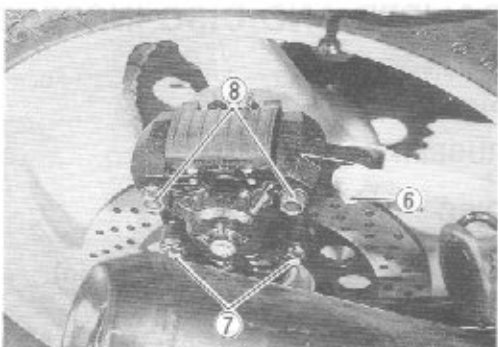

- Remove the seal ①.

**NOTE:**

Once separate the caliper halves, replace the seal with a new one.

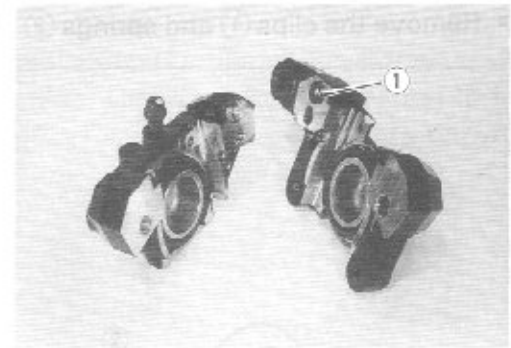

- Placing a rag over the piston to prevent the popping out, push out the piston using air gun.

**CAUTION:**

To prevent the piston damage, do not use high pressure air.



- Remove the piston ②, dust boot ③ and piston seal ④.

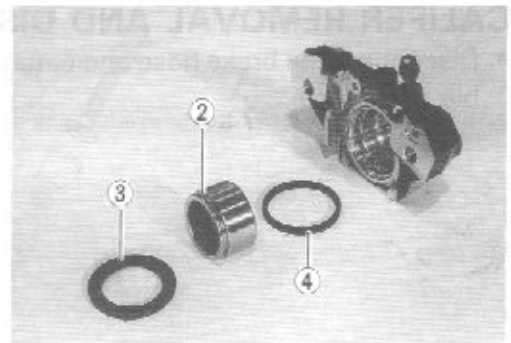

**CALIPER AND DISC INSPECTION**

CYLINDER ..... Refer to page 7-14.

PISTON ..... Refer to page 7-14.

RUBBER PARTS ..... Refer to page 7-14.

DISC ..... Refer to page 7-15.

Service Limit: 5.5 mm (0.217 in)

**CALIPER REASSEMBLY AND REMOUNTING**

Reassemble and remount the caliper in the reverse order of removal and disassembly and also carry out the following steps:

**CAUTION:**

- \* Wash the caliper components with fresh brake fluid before reassembly.
- \* Never use cleaning solvent or gasoline to wash them.
- \* Apply brake fluid to caliper bore and also piston to be inserted into the bore.
- \* Bleed air after reassembling caliper. (See page 2-15.)



## MASTER CYLINDER REMOVAL AND DISASSEMBLY

- Remove the fairing. (Refer to page 7-1.)
- Remove the right frame cover.
- Remove the rear brake reservoir tank mounting bolt.
- Remove the hose clamps.



- Remove the master cylinder by removing the mounting bolts.
- Remove the pin by removing the cotter pin.

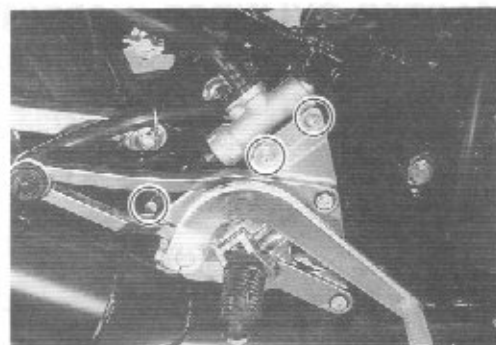

- Place a cloth underneath the union bolt on the master cylinder to catch spilled drops of brake fluid. Unscrew the union bolt and disconnect the brake hose from the master cylinder joint.



### CAUTION:

Immediately and completely wipe off any brake fluid contacting with any part of motorcycle. The fluid reacts chemically with paint, plastics and rubber materials, etc. and will damage them severely.

- Remove the master cylinder with reservoir tank.
- Remove the master cylinder by removing the hose connector.



- Remove the dust boot (1), and remove the circlip (2) with the special tool.

09900-06105: Snap ring pliers

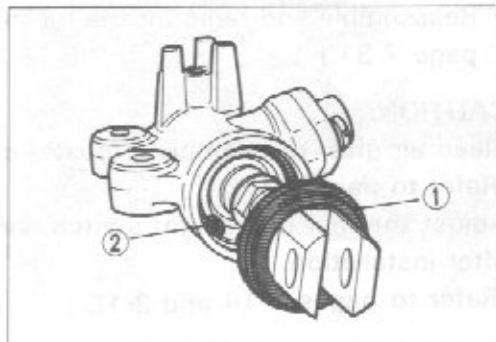



- Draw out the piston/cup set and push rod.

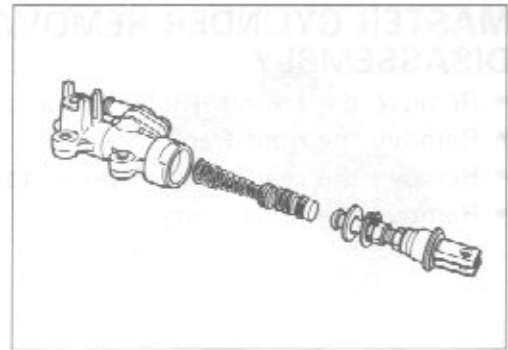

### MASTER CYLINDER INSPECTION

Inspect the cylinder bore wall for any scratches or other damage.

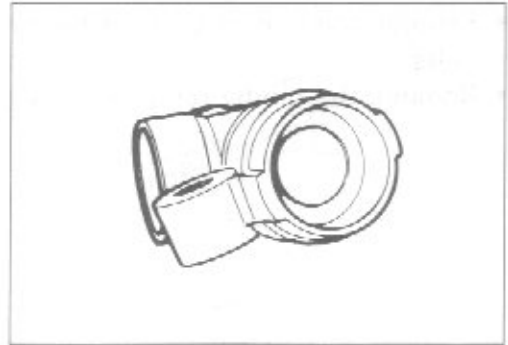

Inspect the piston surface for scratches or other damage. Inspect the primary cup for damage.

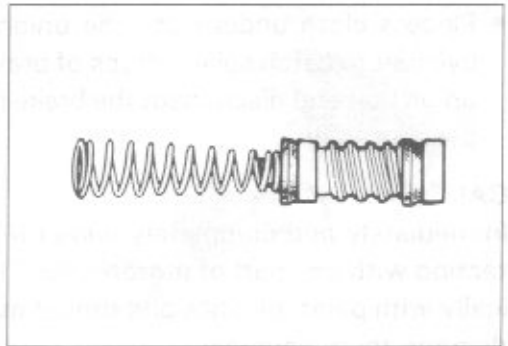

### MASTER CYLINDER REASSEMBLY AND REMOUNTING

Reassemble and remount the master cylinder in the reverse order of removal and disassembly and also carry out the following steps:

#### CAUTION:

- \* Wash the master cylinder components with fresh brake fluid before reassembly. Never use cleaning solvent or gasoline to wash them.
- \* Apply brake fluid to the cylinder bore and all the internals to be inserted into the bore.
- Reassemble and remount the master cylinder. (Refer to page 7-31.)



#### CAUTION:

Bleed air after reassembling master cylinder. (Refer to page 2-15.)

Adjust the rear brake light switch and brake pedal height after installation.

(Refer to pages 2-14 and 2-15.)

# REAR SWINGARM AND SUSPENSION

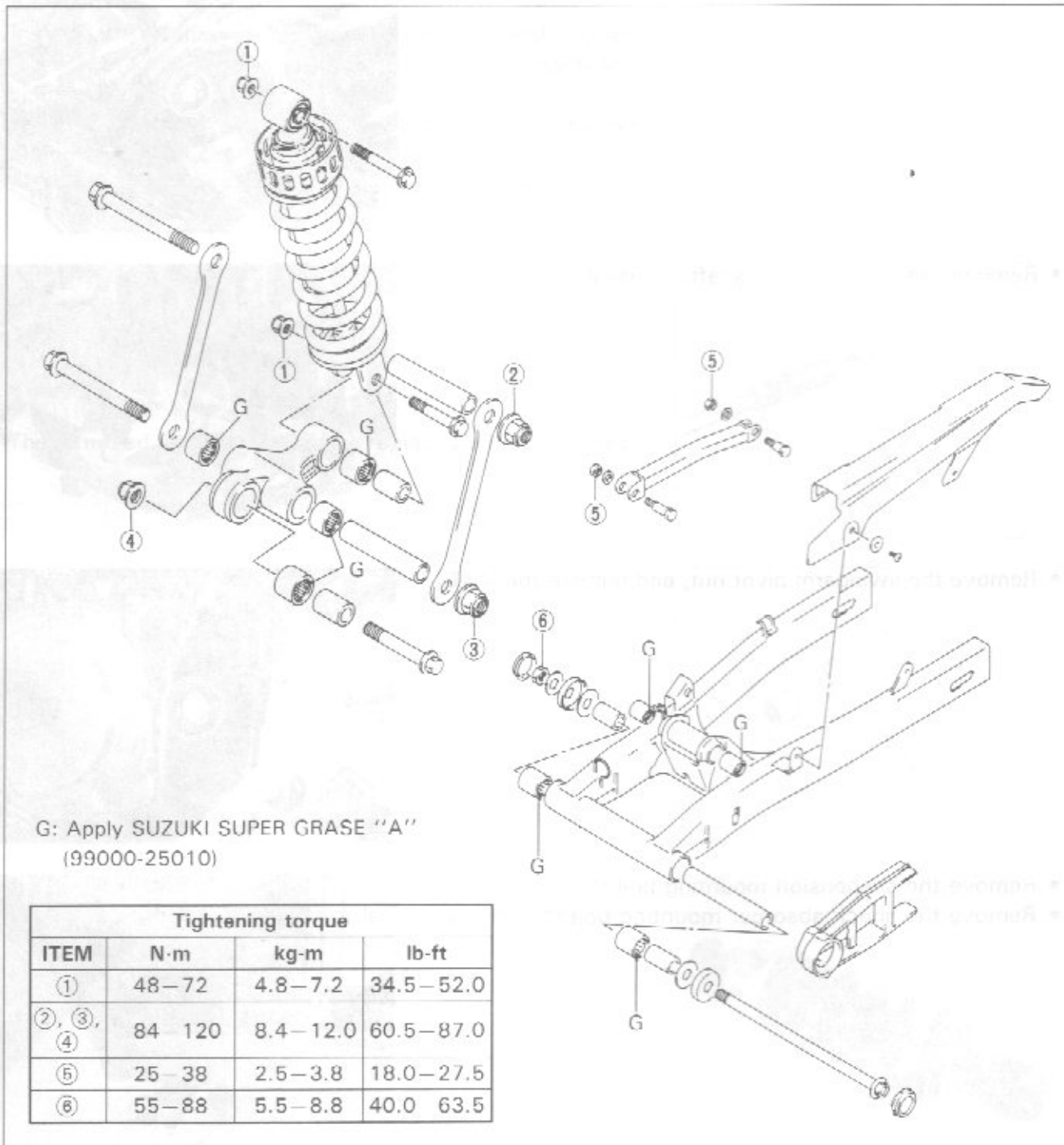

## REMOVAL

- Remove the lower fairing, seat and both frame cover.
- Remove the rear wheel. (Refer to page 7-28.)
- Remove the rear brake. (Refer to pages 7-31 and 7-34.)
- Remove the chain cover.

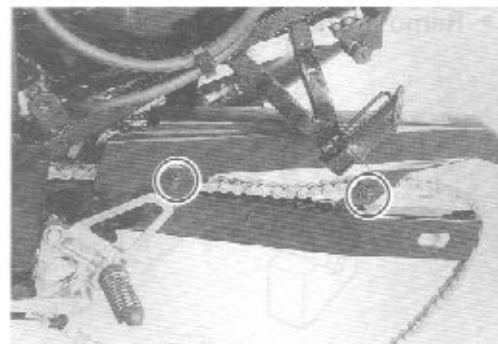

- Remove the rear shock absorber upper mounting bolt.

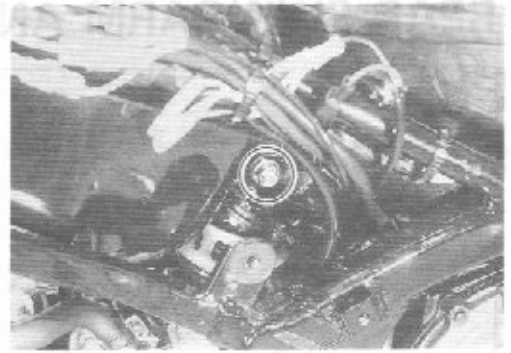

- Remove the cushion lever shaft.

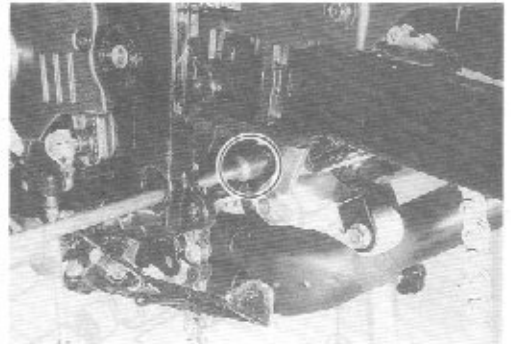

- Remove the swingarm pivot nut, and remove the shaft.

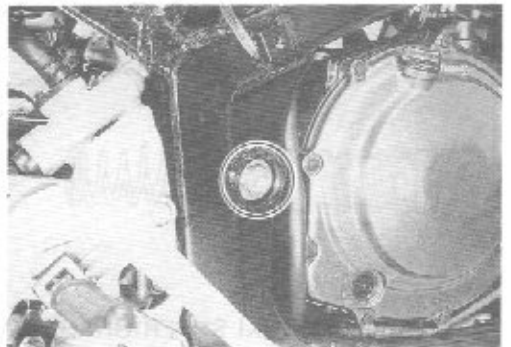

- Remove the suspension mounting bolt ①.
- Remove the shock absorber mounting bolt ②.

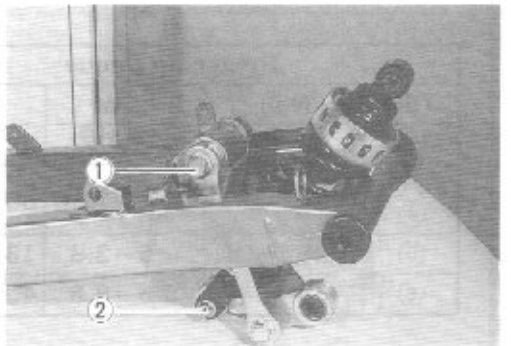

- Remove the dust seal ③, washer ④ and spacer ⑤.

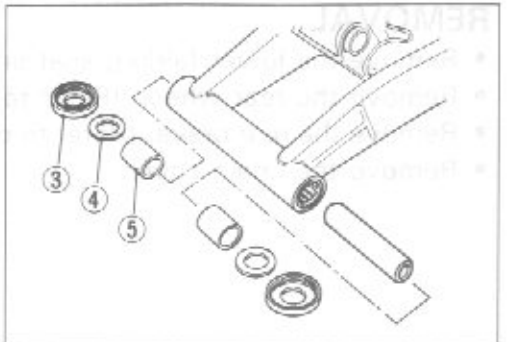

## INSPECTION AND DISASSEMBLY

### BEARING

Inspect the rotation of the swingarm bearing and cushion lever bearing by hand while fixing it in the swingarm and cushion lever.

Rotate the needle roller bearing by hand to inspect whether abnormal noise occurs or it rotates smoothly.

Replace the bearing if there is anything unusual.

- Remove the bearings from the swingarm and cushion lever with the special tools.

**09923-73210: Bearing remover**

**09930-30102: Sliding shaft**

#### CAUTION:

The removed bearings should be replaced with new ones.

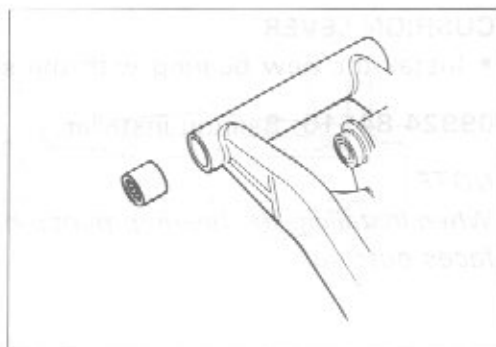
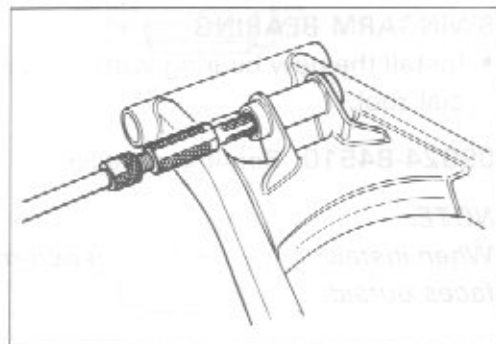

### SHOCK ABSORBER

Inspect the shock absorber for oil leakage or other damage.

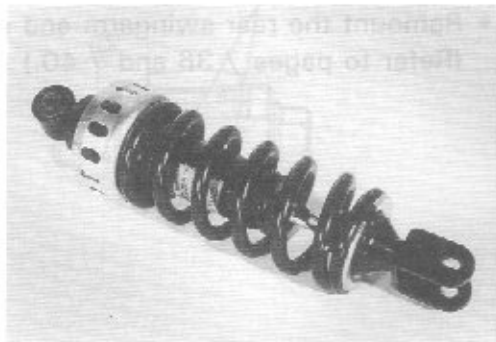

### SWINGARM PIVOT SHAFT

Check the pivot shaft for runout with the special tools.

**Service Limit: 0.3 mm (0.01 in)**

**09900-20606: Dial gauge**

**09900-20701: Magnetic stand**

**09900-21304: V-block**

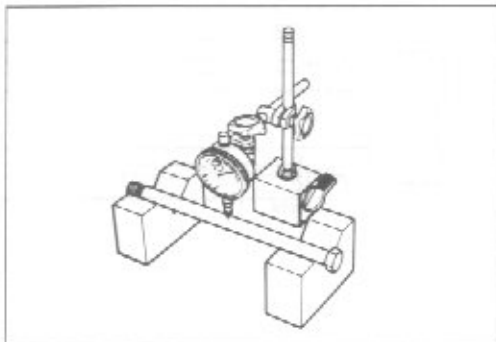

## REASSEMBLY AND REMOUNTING

Reassemble and remount the rear swingarm and suspension in the reverse order of removal and disassembly, and also carry out the following steps:

### SWINGARM BEARING

- Install the new bearing with the suitable socket and special tool.

**09924-84510: Bearing installer**

**NOTE:**

*When installing the bearing, punch-marked side of bearing faces outside.*

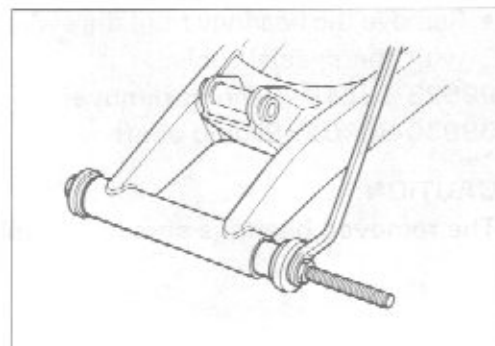

### CUSHION LEVER

- Install the new bearing with the special tool.

**09924-84510: Bearing installer**

**NOTE:**

*When installing the bearing, punch-marked side of bearing faces outside.*

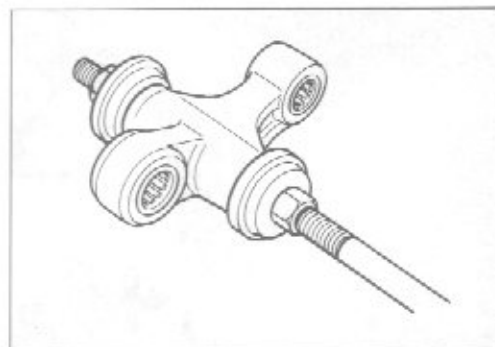

- Remount the rear swingarm and suspension. (Refer to pages 7-36 and 7-40.)

# REASSEMBLING INFORMATION

Tightening torque			
ITEM	N·m	kg·m	lb·ft
(A), (B)	48 72	4.8-7.2	34.5-52.0
(C), (D) (E)	84-120	8.4-12.0	60.5-87.0
(F)	55-88	5.5-8.8	40.0 63.5

G: Apply SUZUKI SUPER GREASE "A"  
(99000 25010)

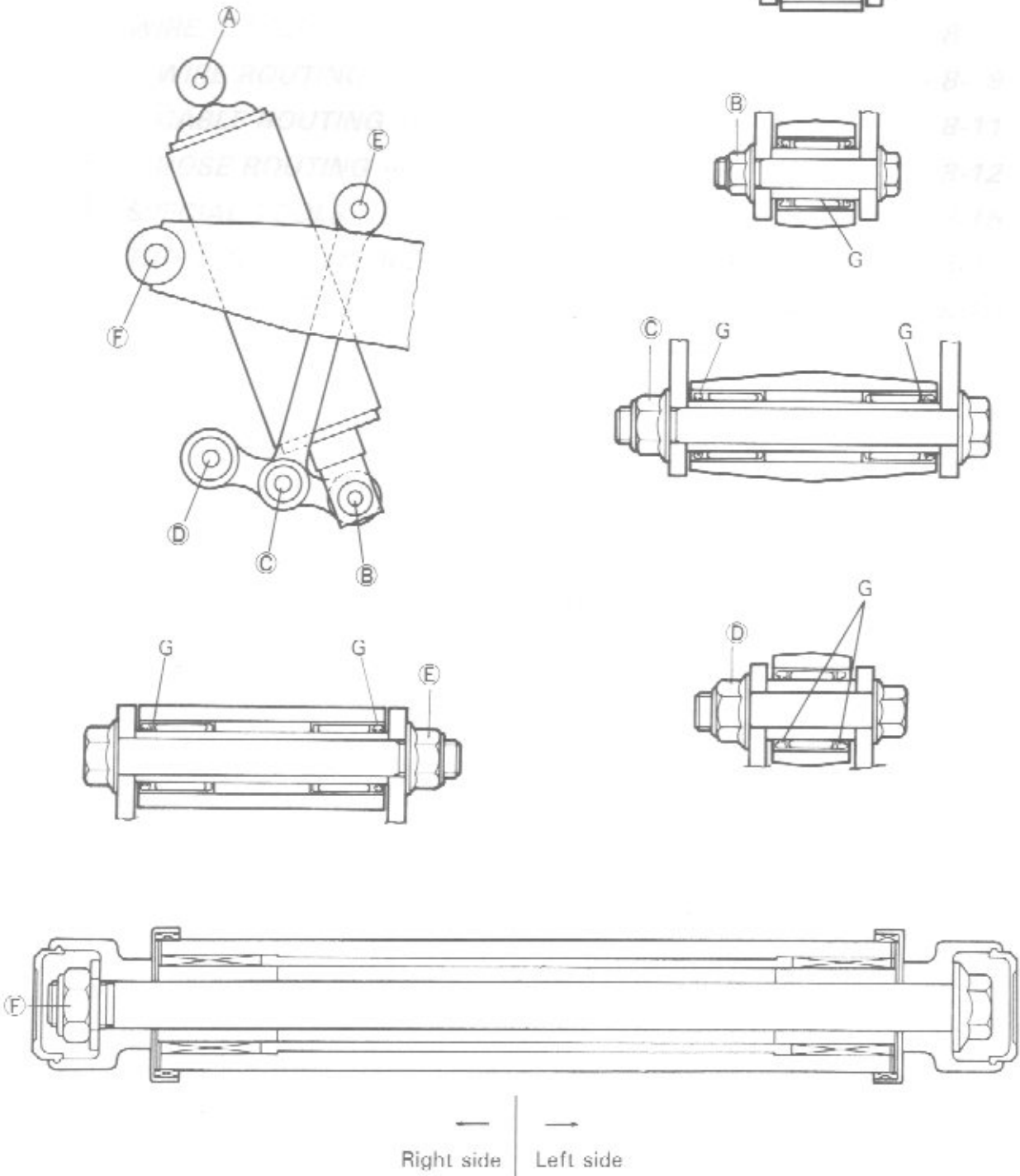

# SERVICING INFORMATION

## CONTENTS

<b>TROUBLESHOOTING</b> .....	<b>8- 1</b>
<b>WIRING DIAGRAM</b> .....	<b>8- 8</b>
<b>WIRE, CABLE AND HOSE ROUTING</b> .....	<b>8- 9</b>
<b>WIRE ROUTING</b> .....	<b>8- 9</b>
<b>CABLE ROUTING</b> .....	<b>8-11</b>
<b>HOSE ROUTING</b> .....	<b>8-12</b>
<b>SPECIAL TOOLS</b> .....	<b>8-15</b>
<b>TIGHTENING TORQUE</b> .....	<b>8-17</b>
<b>SERVICE DATA</b> .....	<b>8-20</b>

## TROUBLESHOOTING

## ENGINE

COMPLAINT	SYMPTOM AND POSSIBLE CAUSES	REMEDY
Engine does not start, or is hard to start.	<b>Compression too low</b> <ol style="list-style-type: none"> <li>1. Out of adjustment tappet clearance</li> <li>2. Worn valve guide or poor seated valve</li> <li>3. Mistiming valve operation</li> <li>4. Excessively worn piston ring</li> <li>5. Worn down cylinder bore</li> <li>6. Too slow starter motor cranking</li> <li>7. Poor seated spark plug</li> </ol> <b>Spark plug no sparking</b> <ol style="list-style-type: none"> <li>1. Fouled spark plug</li> <li>2. Wet spark plug</li> <li>3. Defective ignition coil</li> <li>4. Opened or shorted high tension cord</li> <li>5. Defective signal generator or ignitor unit</li> </ol> <b>No fuel flow to carburetor</b> <ol style="list-style-type: none"> <li>1. Clogged fuel tank vent hose</li> <li>2. Clogged or defective fuel cock</li> <li>3. Defective carburetor needle valve</li> <li>4. Clogged fuel hose or fuel filter</li> <li>5. Defective fuel pump</li> </ol>	Adjust Repair or replace Adjust Replace Replace or rebore Consult "electrical complaints" Retighten  Clean Clean and dry Replace Replace Replace  Clean or replace Clean or replace Replace Clean or replace Replace
Engine stalls easily.	<ol style="list-style-type: none"> <li>1. Fouled spark plug</li> <li>2. Defective signal generator or ignitor unit</li> <li>3. Clogged fuel hose</li> <li>4. Clogged carburetor jet</li> <li>5. Out of adjustment tappet clearance</li> </ol>	Clean Replace Clean Clean Adjust
Engine is noisy.	<b>Excessive tappet chatter</b> <ol style="list-style-type: none"> <li>1. Too large tappet clearance</li> <li>2. Weakened or broken valve spring</li> </ol> <b>Noise appears to come from piston</b> <ol style="list-style-type: none"> <li>1. Worn down piston or cylinder</li> <li>2. Fouled combustion chamber with carbon</li> <li>3. Worn piston pin or piston ring groove</li> <li>4. Worn piston ring or piston ring groove</li> </ol> <b>Noise appears to come from timing chain</b> <ol style="list-style-type: none"> <li>1. Stretched chain</li> <li>2. Worn sprocket</li> <li>3. No working tension adjuster</li> </ol> <b>Noise appears to come from clutch</b> <ol style="list-style-type: none"> <li>1. Worn countershaft splines or hub</li> <li>2. Worn clutch plate teeth</li> <li>3. Distorted clutch plate</li> <li>4. Worn clutch release bearing</li> <li>5. Weakened clutch damper</li> </ol>	Adjust Replace  Replace Clean Replace Replace  Replace Replace Repair or replace  Replace Replace Replace Replace Replace primary driven gear



COMPLAINT	SYMPTOM AND POSSIBLE CAUSES	REMEDY
Engine is noisy.	<b>Noise appears to come from crankshaft</b> 1. Rattling bearing 2. Worn and burnt big end bearing 3. Worn and burnt journal bearing	Replace Replace Replace thrust bearing
	<b>Noise appears to come from transmission</b> 1. Worn or rubbed gear 2. Badly worn splines 3. Worn or rubbed primary gear 4. Badly worn bearing	Replace Replace Replace Replace
Clutch slips.	1. Out of adjustment or loss of play 2. Weakened clutch springs 3. Worn or distorted pressure plate 4. Distorted clutch plate	Adjust Replace Replace Replace
Clutch drags.	1. Out of adjustment or too much play 2. Weakened some clutch springs 3. Distorted pressure plate or clutch plate	Adjust Replace Replace
Transmission does not shift.	1. Broken gearshift cam 2. Distorted gearshift fork 3. Worn gearshift pawl	Replace Replace Replace
Transmission does not shift back.	1. Broken return spring on shift shaft 2. Rubbed or sticky shift shaft 3. Distorted or worn gearshift fork	Replace Repair Replace
Transmission jumps out of gear.	1. Worn shifting gear on driveshaft or countershaft 2. Distorted or worn gearshift fork 3. Weakened stopper spring on gearshift stopper 4. Worn gearshift pawl	Replace Replace Replace Replace
Engine idles poorly.	1. Out of adjustment tappet clearance 2. Poor seated valve 3. Defective valve guide 4. Too wide spark plug gap 5. Defective ignition coil 6. Defective signal generator or ignitor unit 7. Out of adjustment carburetor fuel level 8. Clogged carburetor jet 9. Unbalance carburetor	Adjust Replace Replace Adjust or replace Replace Replace Adjust Clean Adjust
Engine runs poorly in high speed range.	1. Weakened valve spring 2. Worn camshaft 3. Incorrect valve timing 4. Too narrow spark plug gap 5. Ignition unadvanced sufficiently due to poorly working timing advance circuit 6. Defective ignition coil 7. Defective signal generator or ignitor unit 8. Too low fuel level 9. Clogged air cleaner element 10. Clogged fuel hose	Replace Replace Adjust Adjust  Replace Replace Replace Adjust Clean Clean

COMPLAINT	SYMPTOM AND POSSIBLE CAUSES	REMEDY
Exhaust smoke is dirty or heavy.	<ol style="list-style-type: none"> <li>1. Too much engine oil</li> <li>2. Worn piston ring or cylinder</li> <li>3. Worn valve guide</li> <li>4. Scored or scuffed cylinder wall</li> <li>5. Worn valve stem</li> <li>6. Defective stem seal</li> <li>7. Worn oil ring side rail</li> </ol>	Drain out excess oil Replace Replace Rebore or replace Replace Replace Replace
Engine lacks power.	<ol style="list-style-type: none"> <li>1. Too small tappet clearance</li> <li>2. Weakened valve spring</li> <li>3. Incorrect valve timing</li> <li>4. Worn piston ring or cylinder</li> <li>5. Poor seated valve</li> <li>6. Fouled spark plug</li> <li>7. Incorrect spark plug gap</li> <li>8. Clogged carburetor jet</li> <li>9. Incorrect fuel level</li> <li>10. Clogged air cleaner element</li> <li>11. Loosened carburetor balancing hose or connector</li> <li>12. Unreasonable sucked air</li> <li>13. Too much engine oil</li> </ol>	Adjust Replace Adjust Replace Repair Clean or replace Adjust or replace Clean Adjust Clean Fix Retighten or replace Drain out excess oil
Engine overheats.	<ol style="list-style-type: none"> <li>1. Heavy carbon deposit on piston crown</li> <li>2. Unenough engine oil</li> <li>3. Defective oil pump</li> <li>4. Clogged oil circuit</li> <li>5. Too low fuel level</li> <li>6. Unreasonable sucked air</li> <li>7. Using incorrect engine oil</li> </ol>	Clean Add oil Replace Clean Adjust Retighten or replace Change

## CARBURETOR

COMPLAINT	SYMPTOM AND POSSIBLE CAUSES	REMEDY
Starting troubles.	<ol style="list-style-type: none"> <li>1. Clogged starter jet</li> <li>2. Clogged starter pipe</li> <li>3. Leaked air from joint between starter body and carburetor</li> <li>4. Leaked air from carburetor joint or vaccum gauge joint</li> <li>5. Properly unoperated starter plunger</li> </ol>	Clean Clean Retighten, adjust or replace Check and adjust Check and adjust
Idling or low speed troubles.	<ol style="list-style-type: none"> <li>1. Clogged or loosened pilot jet and pilot air jet</li> <li>2. Leaked air from carburetor joint, vacuum gauge joint or starter</li> <li>3. Clogged pilot outlet or bypass</li> <li>4. Unfully closed starter plunger</li> </ol>	Check and clean Check and clean Check and clean Check and adjust
Medium or high speed troubles.	<ol style="list-style-type: none"> <li>1. Clogged main jet or main air jet</li> <li>2. Clogged needle jet</li> <li>3. Properly unoperated throttle valve</li> <li>4. Clogged fuel filter</li> </ol>	Check and clean Check and clean Check Check and clean

COMPLAINT	SYMPTOM AND POSSIBLE CAUSES	REMEDY
Overflow and/or fuel level fluctuates.	<ol style="list-style-type: none"> <li>1. Worn or damaged needle valve</li> <li>2. Broken needle valve spring</li> <li>3. Properly unworked float</li> <li>4. Adhered foreign matter or needle valve</li> <li>5. Too high or low fuel level</li> </ol>	Replace Replace Check and adjust Clean Adjust

## ELECTRICAL

COMPLAINT	SYMPTOM AND POSSIBLE CAUSES	REMEDY
No-sparking or poor sparking.	<ol style="list-style-type: none"> <li>1. Defective ignition coil</li> <li>2. Defective spark plug</li> <li>3. Defective signal generator or ignitor unit</li> </ol>	Replace Replace Replace
Spark plug fouls soon with carbon.	<ol style="list-style-type: none"> <li>1. Too rich fuel/air mixture</li> <li>2. High idling speed</li> <li>3. Incorrect used gasoline</li> <li>4. Dirty air cleaner element</li> </ol>	Adjust carburetion Adjust Change Clean
Spark plug fouls soon.	<ol style="list-style-type: none"> <li>1. Worn piston ring</li> <li>2. Worn piston or cylinder</li> <li>3. Excessive valve stem/guide clearance</li> <li>4. Worn valve stem oil seal</li> </ol>	Replace Replace Replace Replace
Spark plug electrode overheats on burns.	<ol style="list-style-type: none"> <li>1. Overheated engine</li> <li>2. Loosened spark plug</li> <li>3. Too lean fuel/air mixture</li> </ol>	Tune up Retighten Adjust carburetion
Generator does not charge.	<ol style="list-style-type: none"> <li>1. Opened or shorted lead wire</li> <li>2. Loosened lead connection</li> <li>3. Shorted, grounded or opened generator coil</li> <li>4. Shorted or punctured regulator/rectifier</li> </ol>	Repair or replace Fix Replace Replace
Generator charges below than specification.	<ol style="list-style-type: none"> <li>1. Tended lead wire to get shorted or open-circuited or loosely connected at terminals</li> <li>2. Grounded or open-circuited generator stator coil</li> <li>3. Defective regulator/rectifier</li> <li>4. Defective battery cell plates</li> </ol>	Repair or fix Replace Replace Replace battery
Generator overcharges.	<ol style="list-style-type: none"> <li>1. Short-circuited battery interior</li> <li>2. Damaged or defective regulator/rectifier</li> <li>3. Poorly grounded regulator/rectifier</li> </ol>	Replace battery Replace Clean and tighten
Charging is unstable.	<ol style="list-style-type: none"> <li>1. Lead wire insulation due to vibration, resulting in intermittent shorting</li> <li>2. Shorted generator interior</li> <li>3. Defective regulator/rectifier</li> </ol>	Repair or replace Replace Replace
Starter button is ineffective.	<ol style="list-style-type: none"> <li>1. Run down battery</li> <li>2. Defective switch contact</li> <li>3. Properly unseated brush on starter motor commutator</li> <li>4. Defective starter relay</li> </ol>	Repair or replace Replace Repair or replace Replace

## BATTERY

SYMPTOM	PROBABLE CAUSE	REMEDY
<p><b>Battery runs down quickly.</b></p>	<ol style="list-style-type: none"> <li>1. The charging method is not correct</li> <li>2. Cell plates have lost much of their active material as a result of overcharging</li> <li>3. A short circuit condition exists within the battery due to excessive accumulation of sediments caused by the incorrect electrolyte.</li> <li>4. Battery is too old</li> </ol>	<p>Check the generator, regulator/rectifier and circuit connections, and make necessary adjustments to obtain specified charging operation</p> <p>Replace battery, and correct the charging system</p> <p>Replace battery</p> <p>Replace battery</p>
<p><b>Reversed battery polarity.</b></p>	<p>The battery has been connected the wrong way round in the system, so that it is being charged in the reverse direction</p>	<p>Replace battery and be sure to connect the battery properly</p>
<p><b>Battery discharges too rapidly.</b></p>	<ol style="list-style-type: none"> <li>1. Dirty container top and sides</li> <li>2. Battery is too old</li> </ol>	<p>Clean</p> <p>Replace</p>

## CHASSIS

COMPLAINT	SYMPTOM AND POSSIBLE CAUSES	REMEDY
Steering is heavy.	<ol style="list-style-type: none"> <li>1. Overtightened steering stem nut</li> <li>2. Broken steering stem bearing</li> <li>3. Distorted steering stem</li> <li>4. Unenough tire pressure</li> </ol>	Adjust Rplacc Replace Adjust
Handle is wobbly.	<ol style="list-style-type: none"> <li>1. Unbalance of right and left front forks</li> <li>2. Distorted front fork</li> <li>3. Distorted front axle</li> <li>4. Crooked tire</li> </ol>	Replace Repair or replace Replace Replace
Front wheel is wobbly.	<ol style="list-style-type: none"> <li>1. Distorted wheel rim</li> <li>2. Worn down front wheel bearing</li> <li>3. Defective or incorrect tire</li> <li>4. Loosened front axle</li> <li>5. Incorrect front fork oil level</li> </ol>	Replace Replace Replace Retighten Adjust
Front suspension is too soft.	<ol style="list-style-type: none"> <li>1. Weakened spring</li> <li>2. Unenough fork oil level</li> </ol>	Replace Refill
Front suspension is too stiff.	<ol style="list-style-type: none"> <li>1. Too viscous fork oil</li> <li>2. Too much fork oil</li> </ol>	Replace Drain excess oil
Front suspension is noisy.	<ol style="list-style-type: none"> <li>1. Unenough fork oil level</li> <li>2. Loosened suspension mountings</li> </ol>	Refill Retighten
Rear wheel is wobbly.	<ol style="list-style-type: none"> <li>1. Distorted wheel rim</li> <li>2. Worn down rear wheel or swingarm bearing</li> <li>3. Defective or incorrect tire</li> <li>4. Worn swingarm and rear cushion bearing</li> <li>5. Loosened suspension mountings</li> </ol>	Replace Replace Rplacc Replace Retighten
Rear suspension is too soft.	<ol style="list-style-type: none"> <li>1. Weakened shock absorber spring</li> <li>2. Improper rear suspension adjuster setting</li> <li>3. Leaked shock absorber oil</li> </ol>	Replace Adjust Replace
Rear suspension is too stiff.	<ol style="list-style-type: none"> <li>1. Improper rear suspension adjuster setting</li> <li>2. Bent shock absorber shaft</li> <li>3. Bent swingarm</li> <li>4. Worn swingarm and rear cushion bearing</li> </ol>	Adjust Replace Replace Replace
Rear suspension is noisy.	<ol style="list-style-type: none"> <li>1. Loosened suspension mountings</li> <li>2. Worn swingarm and rear cushion bearing</li> </ol>	Retighten Replace

## BRAKES

COMPLAINT	SYMPTOM AND POSSIBLE CAUSES	REMEDY
Brake power is insufficient.	<ol style="list-style-type: none"> <li>1. Leaked brake fluid</li> <li>2. Worn pad</li> <li>3. Adhered oil to pad surface</li> <li>4. Worn disc</li> <li>5. Entered air in hydraulic system</li> </ol>	Repair or replace Replace Clean disc and pad Replace Bleed air
Brake squeaks.	<ol style="list-style-type: none"> <li>1. Adhered carbon to surface</li> <li>2. Tilted pad</li> <li>3. Damaged wheel bearing</li> <li>4. Loosened front and rear wheel axles</li> <li>5. Worn pad</li> <li>6. Contaminated brake fluid</li> <li>7. Clogged master cylinder return port</li> </ol>	Repair with sandpaper Modify pad fitting Replace Tighten to specified torque Replace Replace brake fluid Clean
Brake lever stroke is excessive.	<ol style="list-style-type: none"> <li>1. Entered air in hydraulic system</li> <li>2. Insufficient brake fluid</li> <li>3. Improper brake fluid quality</li> </ol>	Bleed air Replenish Replace
Brake fluid leaks.	<ol style="list-style-type: none"> <li>1. Insufficient connection joint tightening</li> <li>2. Cracked brake hose</li> <li>3. Worn piston and/or cup</li> </ol>	Retighten Replace Replace

# WIRING DIAGRAM

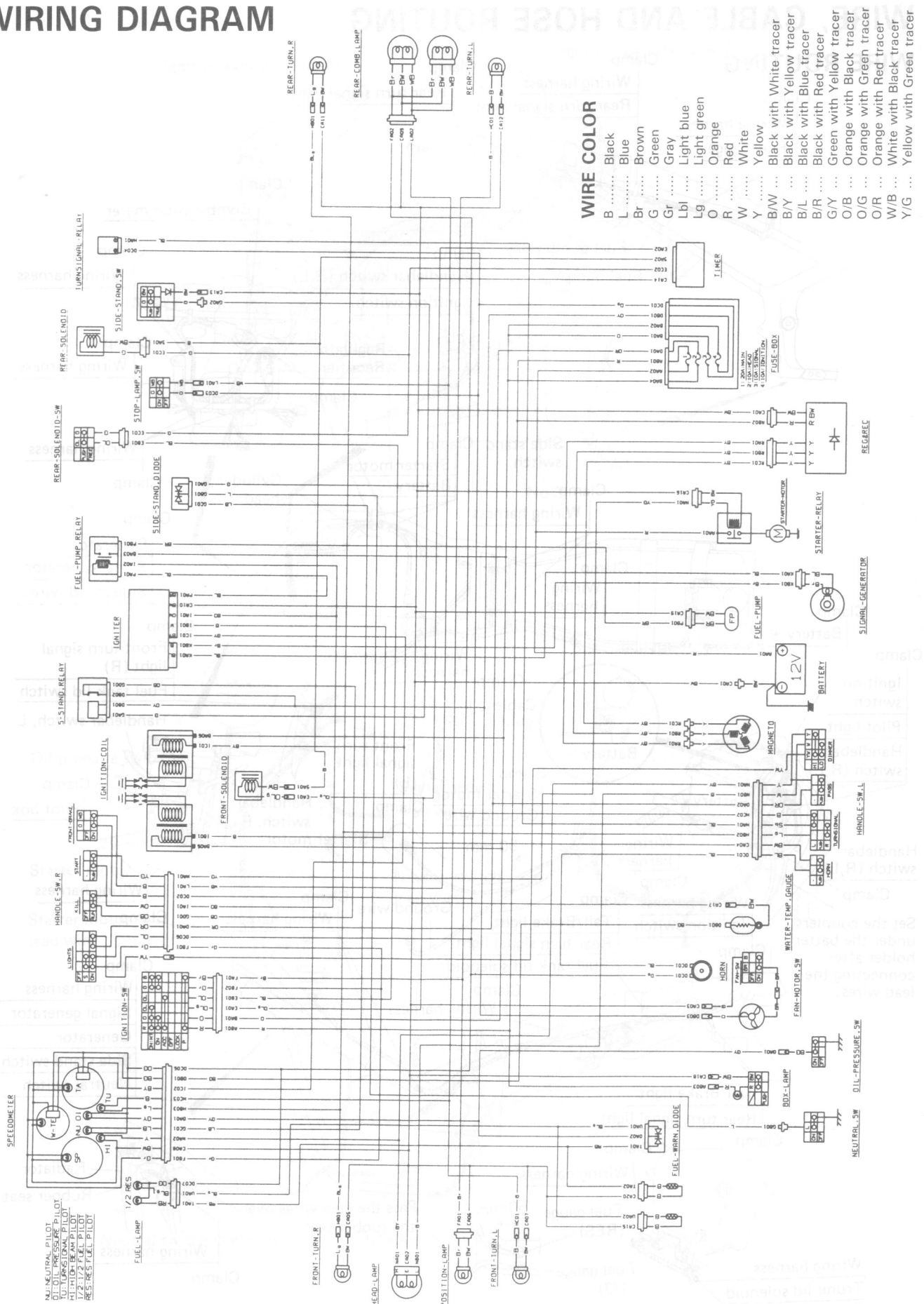





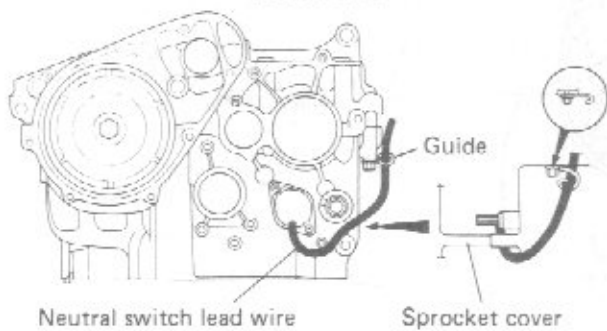
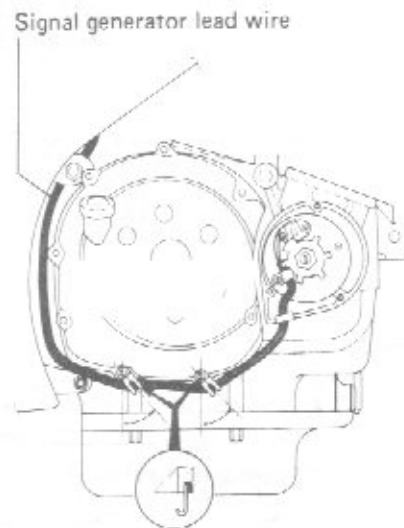
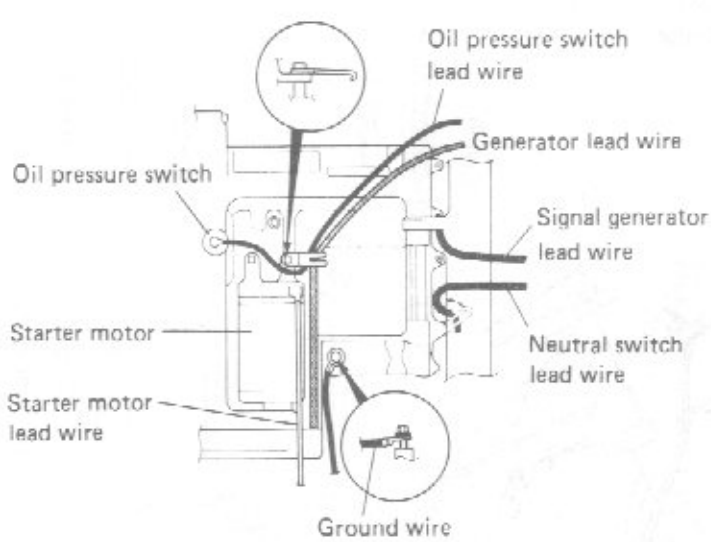
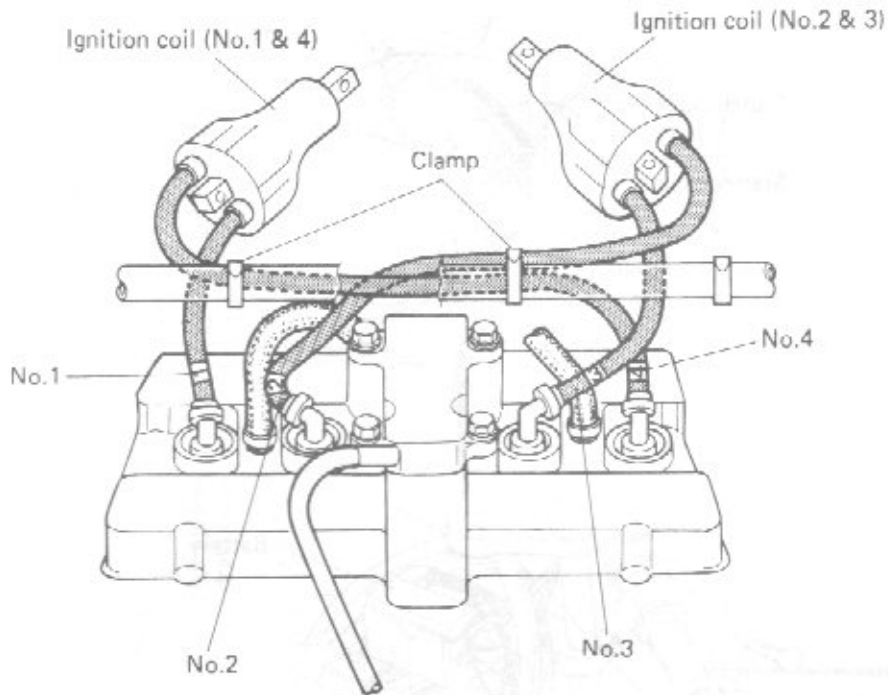

# CABLE ROUTING

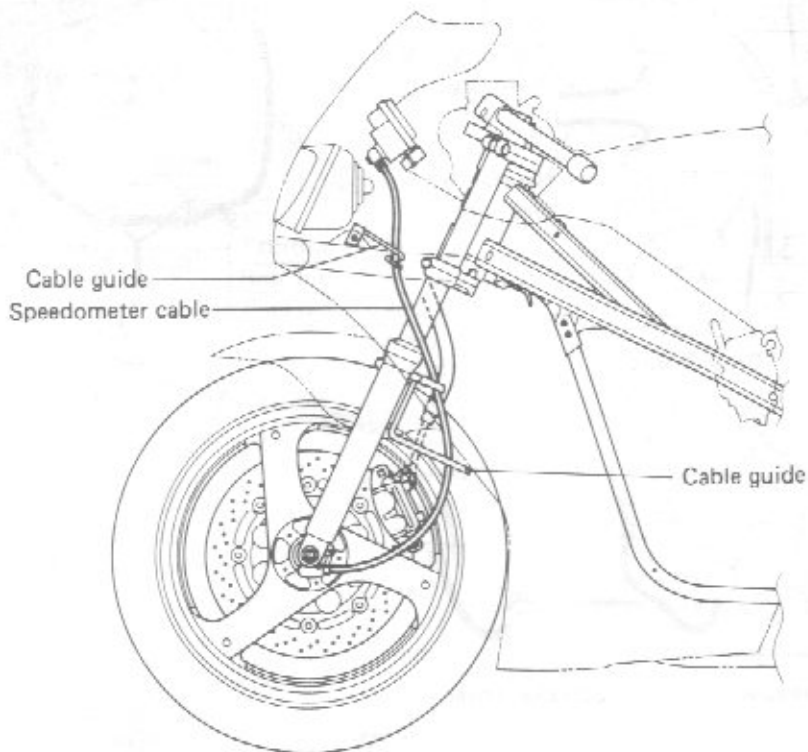
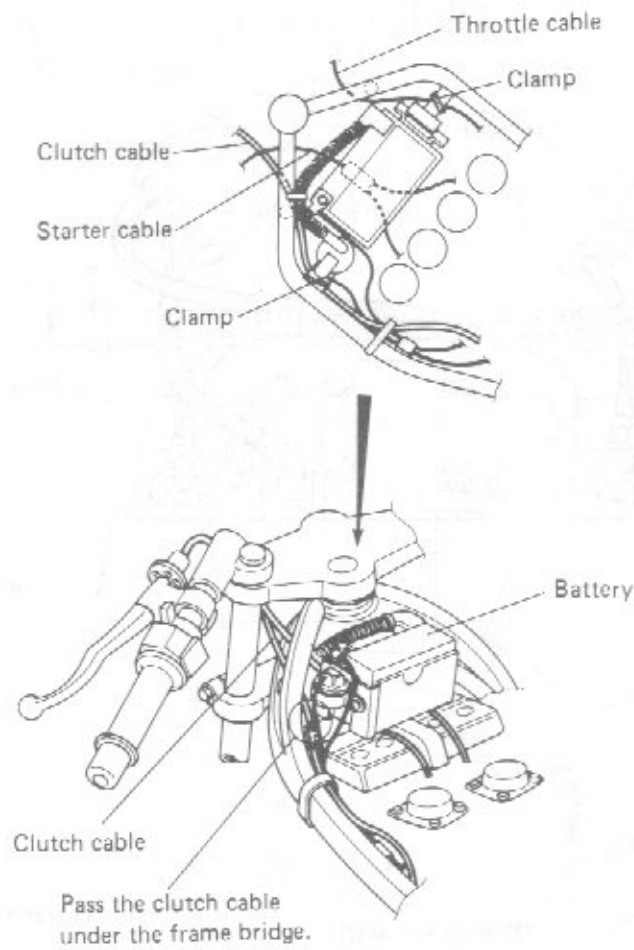

# HOSE ROUTING

Pass the air cleaner drain hose right side at the engine mounting portion and under the lead wires.

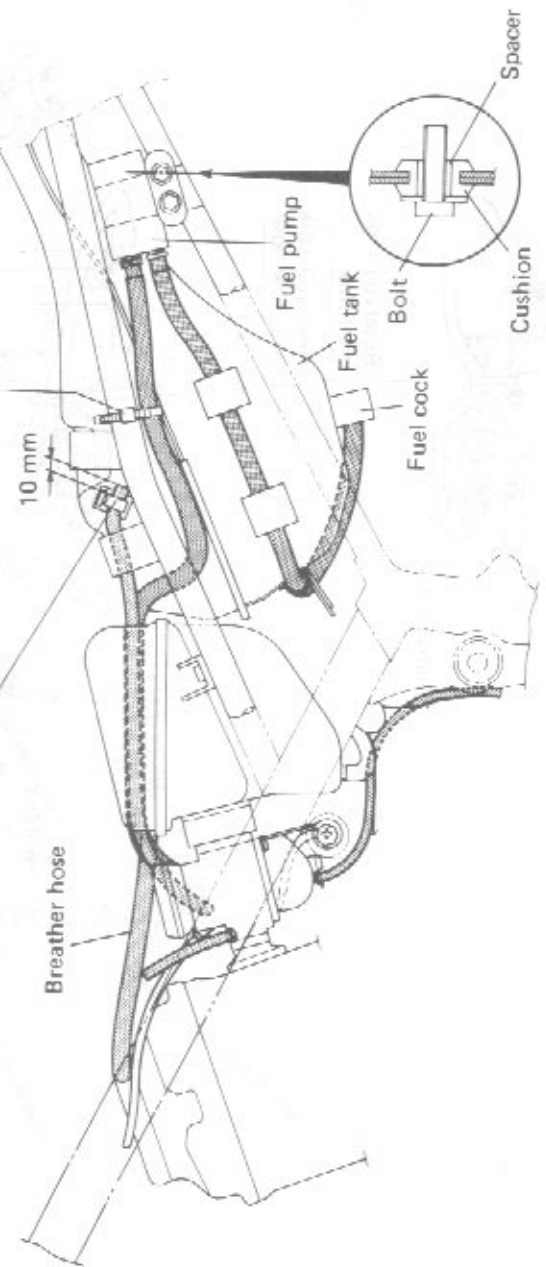
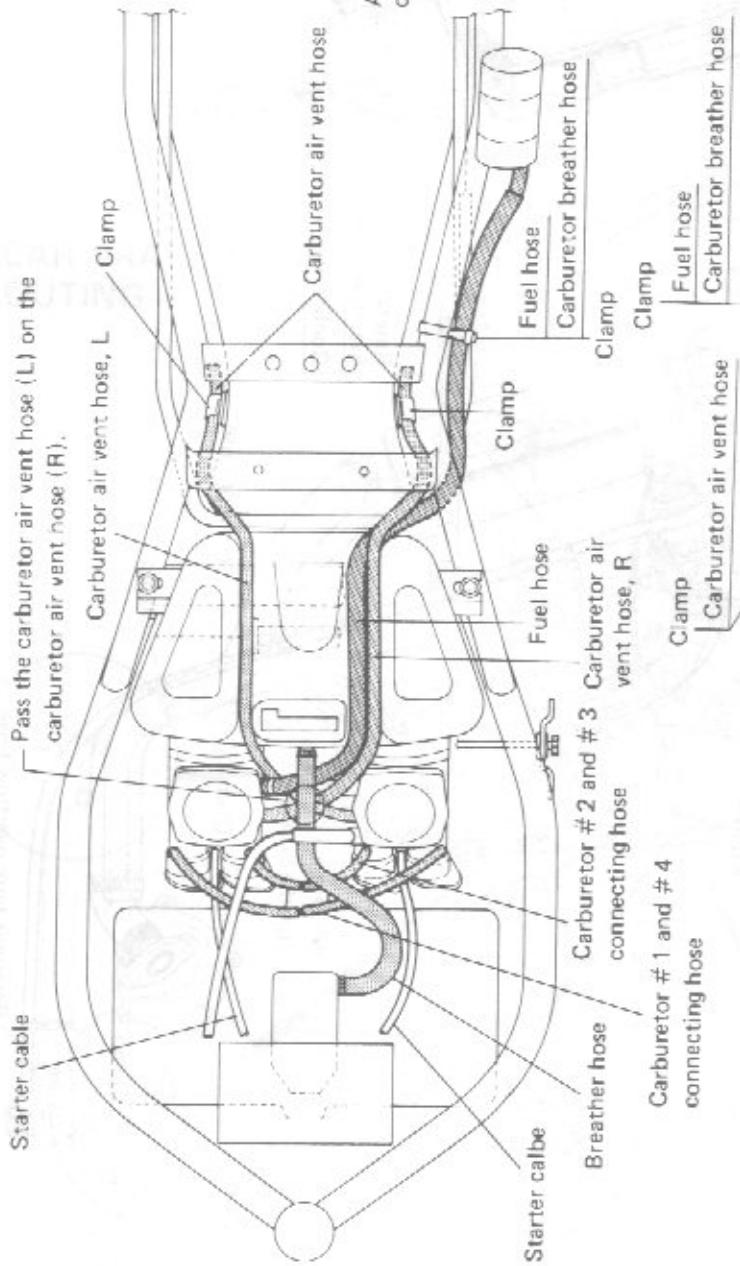
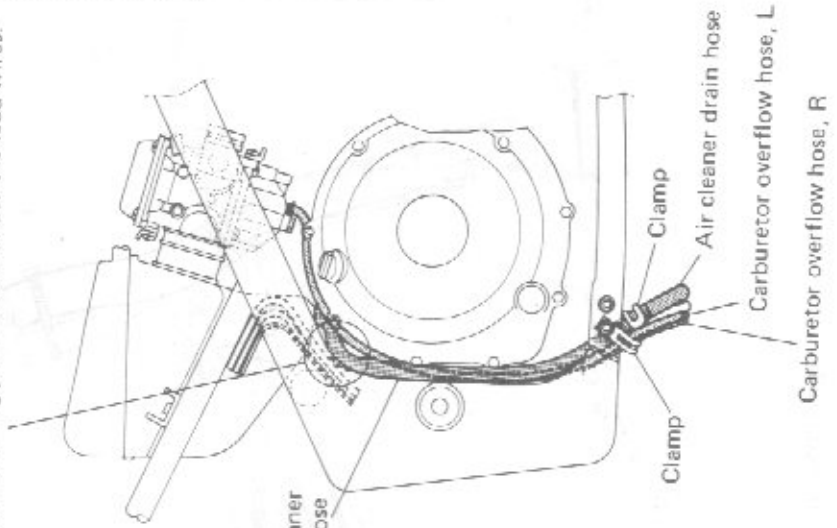

HOSE ROUTING

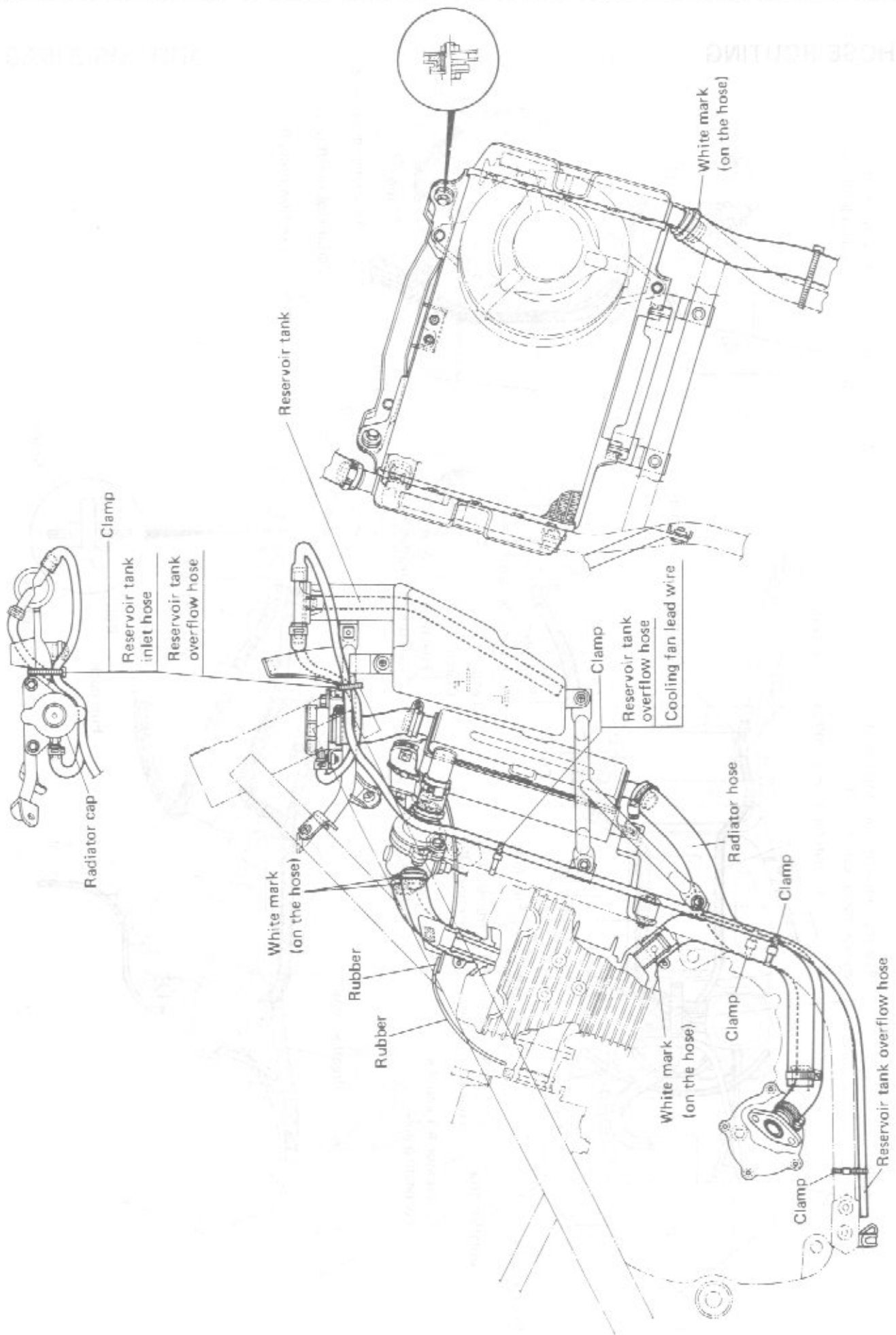

## FRONT BRAKE HOSE ROUTING

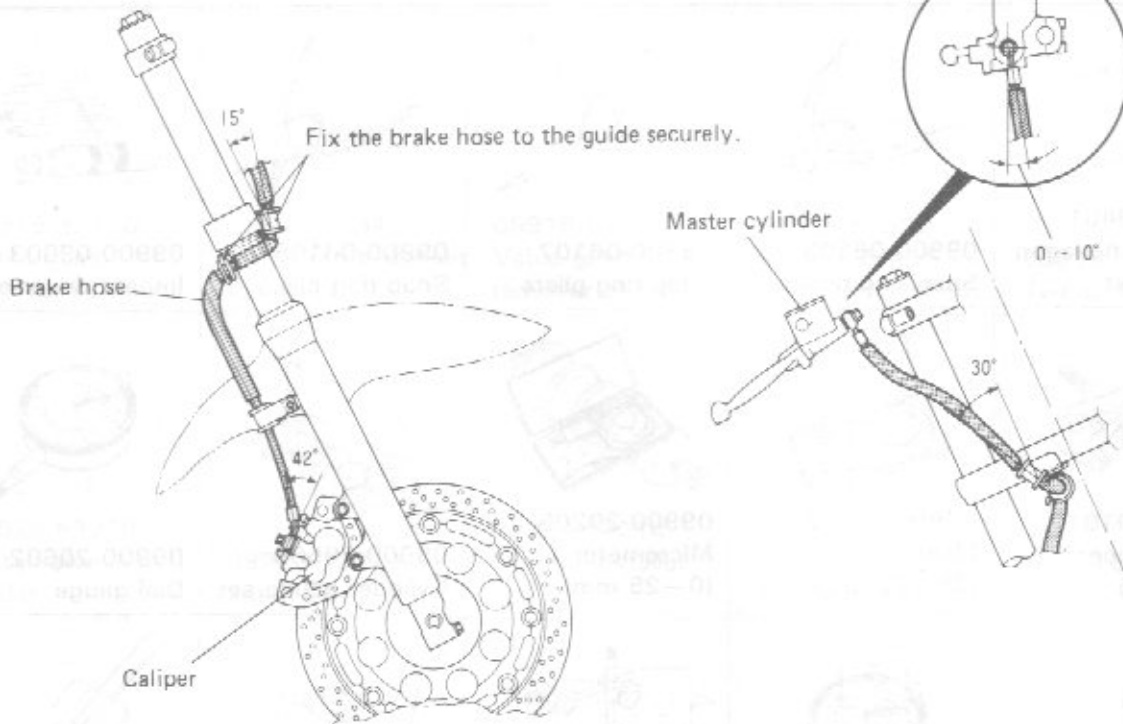

## REAR BRAKE HOSE ROUTING

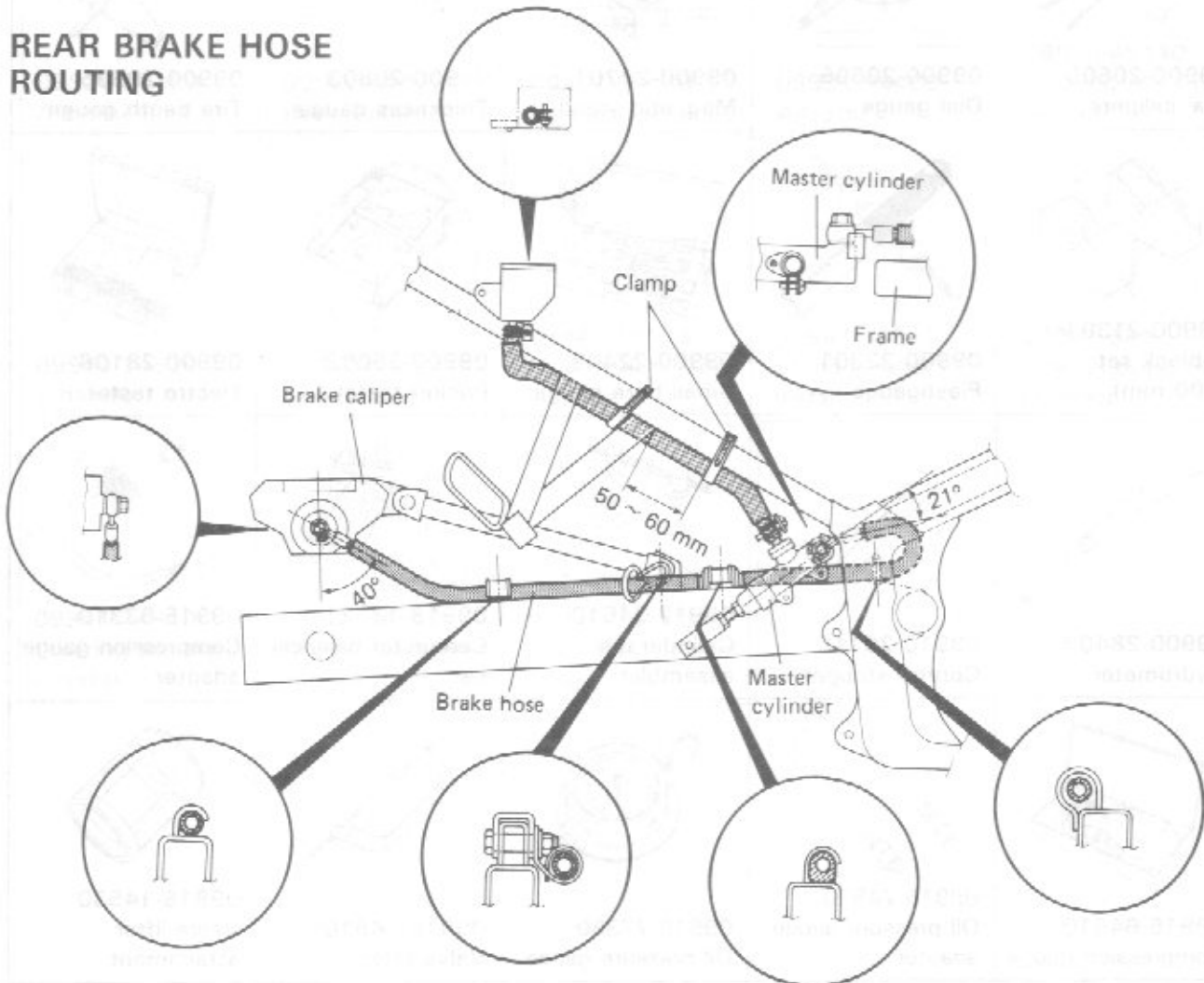

## SPECIAL TOOLS

RIGHT BRAKE HOSE TIGHTENING

				
09900-00401 "L" type hexagon wrench set	09900-06105 Snap ring pliers	09900-06107 Snap ring pliers	09900-06108 Snap ring pliers	09900-09003 Impact driver set
				
09900 20101 Vernir calipers (150 mm)	09900 20202 Micrometer (25-50 mm)	09900-20205 Micrometer (0-25 mm)	09900-20508 Cylinder gauge set	09900-20602 Dial gauge
				
09900-20605 Dial calipers	09900-20606 Dial gauge	09900-20701 Magnetic stand	09900-20803 Thickness gauge	09900-20805 Tire depth gauge
				
09900-21304 V-block set (100 mm)	09900-22301 Plastigauge	09900-22403 Small bore gauge	09900-25002 Pocket tester	09900-28106 Electro tester
				
09900-28403 Hydrometer	09910-20115 Conrod stopper	09912-34510 Cylinder dis- assembler	09913-13121 Carburetor balancer set	09915-63310 Compression gauge adapter
				
09915-64510 Compression gauge	09915-74520 Oil pressure gauge adapter	09915-77330 Oil pressure gauge	09916-14510 Valve lifter	09916-14530 Valve lifter attachment

 <p><b>09916-33310</b> Valve guide remover (4 mm)</p>	 <p><b>09916-34542</b> Valve guide reamer handle</p>	 <p><b>09916-53310</b> Valve guide remover/installer</p>	 <p><b>09916-53320</b> Valve guide in- staller attachment</p>	 <p><b>09916-84511</b> Tweezers</p>
 <p><b>09920-53710</b> Clutch sleeve hub holder</p>	 <p><b>09923-73210</b> Bearing remover</p>	 <p><b>09924-84510</b> Bearing installer set</p>	 <p><b>09930-11910</b> Torx wrench</p>	 <p><b>09930-30102</b> Sliding shaft</p>
 <p><b>09930-30180</b> Attachment E</p>	 <p><b>09930-44913</b> Rotor holder</p>	 <p><b>09931-94430</b> Ignitor checker</p>	 <p><b>09931-94460</b> Adaptor</p>	 <p><b>09940-49110</b> Steering stem nut wrench</p>
 <p><b>09940-34520</b> T handle</p>	 <p><b>09940-34581</b> Attachment F</p>	 <p><b>09940-50113</b> Front fork oil seal installer</p>	 <p><b>09941-34513</b> Steering race installer</p>	 <p><b>09941-54911</b> Bearing outer race remover</p>
 <p><b>09941-74910</b> Steering bearing installer</p>	 <p><b>09941-84510</b> Bearing inner race remover</p>	 <p><b>09943-74111</b> Front fork oil level gauge</p>		

# TIGHTENING TORQUE

## ENGINE

ITEM	N·m	kg·m	lb·ft
Cylinder head cover bolt	13–15	1.3–1.5	9.5–11.0
Cylinder head nut	15–19	1.5–1.9	11.0–13.5
Cylinder head bolt	8–12	0.8–1.2	6.0–8.5
Cylinder stud bolt	13–16	1.3–1.6	9.5–11.5
Chamshaft journal holder bolt	8–12	0.8–1.2	6.0–8.5
Cam sprocket bolt	24–26	2.4–2.6	17.5–19.0
Generator rotor bolt	110–130	11.0–13.0	79.5–94.0
Oil hose mounting bolt (Cylinder head side)	8–12	0.8–1.2	6.0–8.5
Oil hose mounting bolt (Crankcase side)	8–12	0.8–1.2	6.0–8.5
Cam chain tensioner mounting bolt	6–8	0.6–0.8	4.5–6.0
Conrod bearing cap nut	16–17	1.6–1.7	11.5–12.5
Starter clutch bolt	15–19	1.5–1.9	11.0–13.5
Signal generator bolt	23–28	2.3–2.8	16.5–20.0
Crankcase (6 mm)	8–12	0.8–1.2	6.0–8.5
	12–16	1.2–1.6	8.5–11.5
	14–18	1.4–1.8	10.0–13.0
(8 mm)	20–24	2.0–2.4	14.5–17.5
Oil pump mounting bolt	8–12	0.8–1.2	6.0–8.5
Oil drain plug	20–25	2.0–2.5	14.5–18.0
Oil pan bolt	8–12	0.8–1.2	6.0–8.5
Clutch sleeve hub nut	50–70	5.0–7.0	36.0–50.5
Exhaust pipe bolt	8–12	0.8–1.2	6.0–8.5
Muffler mounting bolt	18–28	1.8–2.8	13.0–20.0
Engine mounting nut	60–72	6.0–7.2	43.5–52.0
Water thermo-gauge	6–10	0.6–1.0	4.5–7.0
Water pump impeller bolt	7–9	0.7–0.9	5.0–6.5
Cooling fan switch	9–14	0.9–1.4	6.5–10.0
Thermostat case bolt	6–8	0.6–0.8	4.5–6.0
Coolant drain bolt	8–12	0.8–1.2	6.0–8.5
Oil pressure regulator	25–30	2.5–3.0	18.0–21.5
Oil pressure switch	12–15	1.2–1.5	8.5–11.0
Oil gallerly plug	30–40	3.0–4.0	21.5–29.0



## CHASSIS

ITEM	N-m	kg-m	lb-ft
Steering stem head bolt	35-55	3.5-5.5	25.5-40.0
Front fork upper clamp bolt	18-28	1.8-2.8	13.0-20.0
Front fork lower clamp bolt	25-40	2.5-4.0	18.0-29.0
Front fork cap	15-30	1.5-3.0	11.0-21.5
Front fork damper rod bolt	25-35	2.5-3.5	18.0-25.5
Front axle nut	43-62	4.3-6.2	31.0-45.0
Front axle pinch bolt	20-30	2.0-3.0	14.5-21.5
Handlebar clamp bolt	18-28	1.8-2.8	13.0-20.0
Handlebar holder bolt	40-60	4.0-6.0	29.0-43.5
Handlebar holder nut	27-42	2.7-4.2	19.5-30.5
Front brake caliper mounting bolt	30-47	3.0-4.7	21.5-34.0
Front brake master cylinder bolt	5-8	0.5-0.8	3.5-6.0
Brake hose union bolt (Cylinder & Caliper)	15-20	1.5-2.0	11.0-14.5
Air bleeder valve (Front & Rear)	6-9	0.6-0.9	4.5-6.5
Front and rear disc bolt	18-28	1.8-2.8	13.0-20.0
Front footrest bolt	18-28	1.8-2.8	13.0-20.0
Swingarm pivot nut	55-88	5.5-8.8	40.0-63.5
Rear shock absorber mounting nut (Upper & Lower)	48-72	4.8-7.2	34.5-52.0
Rear cushion rod nut	84-120	8.4-12.0	60.5-87.0
Rear cushion lever nut (Front)	84-120	8.4-12.0	60.5-87.0
Rear cushion lever nut (Center)	84-120	8.4-12.0	60.5-87.0
Rear brake caliper mounting bolt	20-30	2.0-3.0	14.5-21.5
Rear brake caliper housing bolt	30-36	3.0-3.6	21.5-26.0
Rear brake master cylinder mounting bolt	8-12	0.8-1.2	6.0-8.5
Rear brake rod lock nut	15-20	1.5-2.0	11.0-14.5
Rear brake pedal bolt	8-12	0.8-1.2	6.0-8.5
Rear axle nut	55-88	5.5-8.8	40.0-63.5
Rear sprocket nut	48-72	4.8-7.2	35.0-52.0
Rear torque link nut (Front & Rear)	25-38	2.5-3.8	18.0-27.5

## TIGHTENING TORQUE CHART

For other bolts and nuts not listed above, refer to each tightening torque value in the following chart:

Bolt Diameter (mm)	Conventional or "4" marked bolt			"7" marked bolt		
	N-m	kg-m	lb-ft	N-m	kg-m	lb-ft
4	1-2	0.1-0.2	0.7-1.5	1.5-3	0.15-0.3	1.0-2.0
5	2-4	0.2-0.4	1.5-3.0	3-6	0.3-0.6	2.0-4.5
6	4-7	0.4-0.7	3.0-5.0	8-12	0.8-1.2	6.0-8.5
8	10-16	1.0-1.6	7.0-11.5	18-28	1.8-2.8	13.0-20.0
10	22-35	2.2-3.5	16.0-25.5	40-60	4.0-6.0	29.0-43.5
12	35-55	3.5-5.5	25.5-40.0	70-100	7.0-10.0	50.5-72.5
14	50-80	5.0-8.0	36.0-58.0	110-160	11.0-16.0	79.5-115.5
16	80-130	8.0-13.0	58.0-94.0	170-250	17.0-25.0	123.0-181.0
18	130-190	13.0-19.0	94.0-137.5	200-280	20.0-28.0	144.5-202.5

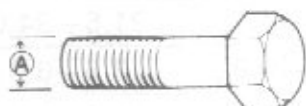

Conventional bolt

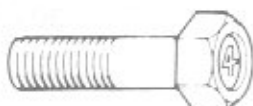

"4" Marked Bolt

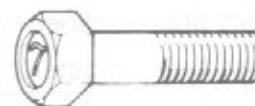

"7" Marked bolt

## SERVICE DATA

## VALVE + GUIDE

Unit: mm (in)

ITEM	STANDARD		LIMIT
Valve diam.	IN.	18.35 (0.72)	—
	EX.	16.0 (0.63)	—
Valve lift	IN.	6.65 (0.26)	—
	EX.	6.1 (0.24)	—
Tappet clearance (when cold)	IN.	0.17–0.27 (0.007–0.011)	—
	EX.	0.20–0.30 (0.008–0.012)	—
Valve guide to valve stem clearance	IN.	0.020–0.047 (0.0008–0.0019)	0.35 (0.014)
	EX.	0.035–0.062 (0.0014–0.0024)	0.35 (0.014)
Valve guide I.D.	IN. & EX.	4.000–4.012 (0.1575–0.1580)	—
Valve stem O.D.	IN.	3.965–3.980 (0.1561–0.1567)	—
	EX.	3.950–3.965 (0.1555–0.1561)	—
Valve stem runout	IN. & EX.	—	0.05 (0.002)
Valve head thickness	IN. & EX.	—	0.5 (0.02)
Valve seat width	IN. & EX.	0.7–0.9 (0.028–0.035)	—
Valve head radial runout	IN. & EX.	—	0.03 (0.001)
Valve spring free length	IN. & EX.	—	38.3 (1.51)
Valve spring tension	IN. & EX.	11.7–14.3 kg (25.8–31.5 lbs) at length 35.3 mm (1.39 in)	—

## CAMSHAFT + CYLINDER HEAD

Unit: mm (in)

ITEM	STANDARD		LIMIT
Cam height	IN.	32.627–32.667 (1.2845–1.2861)	32.330 (1.2728)
	EX.	32.040–32.080 (1.2614–1.2630)	31.740 (1.2496)
Camshaft journal oil clearance	IN. & EX.	0.032–0.066 (0.0013–0.0026)	0.150 (0.0059)
Camshaft journal holder I.D.	IN. & EX.	22.012–22.025 (0.8666–0.8671)	—

ITEM	STANDARD		LIMIT
Camshaft journal O.D.	IN. & EX.	21.959–21.980 (0.8645–0.8654)	—
Camshaft runout	IN. & EX.	—	0.10 (0.004)
Cam chain 20-pitch length	—		128.9 (5.07)
Cam chain pin (at arrow "3")	16th pin		—
Cylinder head distortion	—		0.20 (0.008)

**CYLINDER + PISTON + PISTON RING**

Unit: mm (in)

ITEM	STANDARD		LIMIT	
Compression pressure	1 100–1 700 kPa (11–17 kg/cm <sup>2</sup> ) (156–241 psi)		900 kPa (9 kg/cm <sup>2</sup> ) (128 psi)	
Compression pressure difference	—		200 kPa (2 kg/cm <sup>2</sup> ) (28 psi)	
Piston to cylinder clearance	0.040–0.050 (0.0016–0.0020)		0.120 (0.0047)	
Cylinder bore	49.000–49.015 (1.9291–1.9297)		49.090 (1.9327)	
Piston diam.	48.955–48.970 (1.9274–1.9279) Measure at 10 mm (0.4 in) from the skirt end.		48.880 (1.9244)	
Cylinder distortion	—		0.20 (0.008)	
Piston ring free end gap	1st	R	Approx. 7.0 (0.28)	5.6 (0.22)
	2nd	R	Approx. 5.2 (0.20)	4.2 (0.17)
Piston ring end gap	1st	0.10–0.25 (0.004–0.010)		0.7 (0.03)
	2nd	0.25–0.45 (0.010–0.018)		0.7 (0.03)
Piston ring to groove clearance	1st	—		0.180 (0.0071)
	2nd	—		0.150 (0.0059)
Piston ring groove width	1st	0.81–0.83 (0.032–0.033)		—
	2nd	0.81–0.83 (0.032–0.033)		—
	Oil	2.01–2.03 (0.079–0.080)		—
Piston ring thickness	1st	0.77–0.79 (0.030–0.031)		—
	2nd	0.77–0.79 (0.030–0.031)		—

## THERMOSTAT + RADIATOR + FAN

ITEM		STANDARD	LIMIT
Thermostat valve opening temperature		74.5–78.5°C (166–173°F)	—
Thermostat valve lift		Over 7 mm (0.28 in) at 90°C (194°F)	—
Water thermo-gauge resistance		Approx. 167 Ω at 50°C	—
		Approx. 17 Ω at 120°C	—
Radiator cap valve opening pressure		110 ± 15 kPa (1.1 ± 0.15 kg/cm <sup>2</sup> , 15.6 ± 2.1 psi)	—
Electric fan thermo-switch operating temperature	ON	Approx. 105°C (221°F)	—
	OFF	Approx. 100°C (212°F)	—

## TRANSMISSION + DRIVE CHAIN

Unit: mm (in) Except ratio

ITEM		STANDARD	LIMIT
Primary reduction ratio		2.285 (80/35)	—
Final reduction ratio		3.769 (49/13)	—
Gear ratios	Low	3.083 (37/12)	—
	2nd	2.200 (33/15)	—
	3rd	1.722 (31/18)	—
	4th	1.450 (29/20)	—
	5th	1.315 (25/19)	—
	Top	1.227 (27/22)	—
Shift fork to groove clearance		0.1–0.3 (0.004–0.012)	0.5 (0.02)
Shift fork groove width	No.1 & No.2	5.0–5.1 (0.197–0.201)	—
Shift fork thickness	No.1 & No.2	4.8–4.9 (0.189–0.193)	—
Countershaft length (Low to 2nd)		101.1–101.2 (3.980–3.984)	—
Drive chain	Type	D.I.D.: 520 V <sub>7</sub> TAKASAGO: RK520SMO	—
	Links	110	—
	20-pitch length	—	319.4 (12.57)
Drive chain slack		15–25 (0.6–1.0)	—
Gearshift lever height		50 (2.0)	—

ITEM	STANDARD	LIMIT
Piston pin bore	14.002–14.008 (0.5513–0.5515)	14.030 (0.5524)
Piston pin O.D.	13.995–14.000 (0.5510–0.5512)	13.980 (0.5504)

**CONROD + CRANKSHAFT**

Unit: mm (in)

ITEM	STANDARD	LIMIT
Conrod small end I.D.	14.010–14.018 (0.5516–0.5519)	14.040 (0.5528)
Conrod big end side clearance	0.1–0.2 (0.004–0.008)	0.3 (0.012)
Conrod big end width	15.95–16.00 (0.628–0.630)	—
Crank pin width	16.10–16.15 (0.634–0.636)	—
Conrod big end oil clearance	0.024–0.048 (0.0009–0.0019)	0.080 (0.0031)
Crank pin O.D.	26.976–27.000 (1.0620–1.0630)	—
Crankshaft journal oil clearance	0.020–0.044 (0.0008–0.0017)	0.080 (0.0031)
Crankshaft journal O.D.	27.976–28.000 (1.1014–1.1024)	—
Crankshaft thrust clearance	0.045–0.100 (0.0018–0.0039)	—
Crankshaft thrust bearing thickness	R	2.425–2.450 (0.0955–0.0965)
	L	2.420–2.575 (0.0953–0.1014)
Crankshaft runout	—	0.05 (0.002)

**OIL PUMP**

ITEM	STANDARD	LIMIT
Oil pump reduction ratio	2.878 (34/27 x 80/35)	—
Oil pressure (at 60°C, 140°F)	Above 200 kPa (2.0 kg/cm <sup>2</sup> , 28 psi) Below 400 kPa (4.0 kg/cm <sup>2</sup> , 57 psi) at 3 000 r/min.	—

**CLUTCH**

Unit: mm (in)

ITEM	STANDARD	LIMIT
Clutch cable play	4 (0.16)	—
Clutch release screw	¼ turn back	—
Drive plate thickness	2.9–3.1 (0.11–0.12)	2.6 (0.10)
Drive plate claw width	11.8–12.0 (0.46–0.47)	11.2 (0.44)
Driven plate distortion	—	0.10 (0.004)
Clutch spring free length	—	36.3 (1.43)

## CARBURETOR

ITEM	SPECIFICATION
Carburetor type	MIKUNI BSW27
Bore size	27 mm
I.D. No	24D0
Idle r/min.	1 600 ± 100 r/min
Float height	20.5 ± 1.0 mm
Main jet (M.J.)	# 90
Main air jet (M.A.J.)	1.4 mm
Jet needle (J.N.)	5D52-3rd
Needle jet (N.J.)	O-1
Throttle valve (Th.V.)	# 85
Pilot jet (P.J.)	# 30
By-pass (B.P.)	0.8, 0.8, 0.8 mm
Pilot outlet (P.O.)	0.9 mm
Valve seat (V.S.)	1.0 mm
Starter jet (G.S.)	# 22.5
Pilot screw (P.S.)	PRE-SET (1½ turns back)
Throttle cable play	0.5–1.0 mm (0.02–0.04 in)
Choke cable play	0.5–1.0 mm (0.02–0.04 in)

## ELECTRICAL

Unit: mm (in)

ITEM	SPECIFICATION	NOTE	
Ignition timing	20° B.T.D.C. below 1 800 r/min.		
Firing order	1,2,4,3		
Spark plug	Type	ND.: U22FSR U N.G.K.: CR7HSA	
	Gap	0.6–0.7 (0.024–0.028)	
Spark performance	Over 8 (0.3) at 1 atm.		
Signal coil resistance	Approx. 400 Ω		
Ignition coil resistance	Primary	2.0–4.0 Ω	Terminal – Terminal
	Secondary	36–56 kΩ	Plug cap – Plug cap
Generator no-load voltage	More than 50 V (AC) at 5 000 r/min.		
Regulated voltage	13.5–15.5 V at 5 000 r/min.		
Starter motor brush length	ND	Limit: 3.5 (0.14)	
	commutator under-cut	Limit: 0.2 (0.008)	
Starter relay resistance	2–6 Ω		
Battery	Type designation	YTX7A-BS or FTX7A-BS	
	Capacity	12 V 21.6 kC (6 Ah)/10HR	
	Standard electrolyte S.G.	1.320 at 20°C (68°F)	
Fuse size	Headlight	10 A	
	Signal	10 A	
	Ignition	10 A	
	Main	25 A	

## WATTAGE

Unit: W

ITEM		SPECIFICATION
Headlight	HI	60
	LO	55
Position light		4
Tail/Brake light		5/18 x 2
Turn signal light		15
Tachometer light		3
Speedometer light		3
Water Temp. meter light		3
Turn signal indicator light		3 x 2
High beam indicator light		1.7
Neutral indicator light		3
Oil pressure indicator light		3
Fuel level light	Yellow	1.7
	Red	3
Trunk light		2

## BRAKE + WHEEL

Unit: mm (in)

ITEM		STANDARD	LIMIT
Rear brake pedal height		50 (2.0)	—
Brake disc thickness	Front	4.5 ± 0.2 (0.177 ± 0.008)	4.0 (0.157)
Brake disc runout		—	0.30 (0.012)
Master cylinder bore	Front	12.700–12.743 (0.5000–0.5017)	—
	Rear	12.700–12.743 (0.5000–0.5017)	—
Master cylinder piston diam.	Front	12.657–12.684 (0.4983–0.4994)	—
	Rear	12.657–12.684 (0.4983–0.4994)	—
Brake caliper cylinder bore	Leading	Front	27.000–27.076 (1.0630–1.0660)
		Trailing	33.960–34.036 (1.3370–1.3400)
	Rear	38.180–38.256 (1.5031–1.5061)	—
Brake caliper piston diam.	Leading	Front	26.920–26.970 (1.0598–1.0618)
		Trailing	33.884–33.934 (1.3340–1.3360)
	Rear	38.098–38.148 (1.4999–1.5019)	—



ITEM	STANDARD		LIMIT
Wheel rim runout	Axial	—	2.0 (0.08)
	Radial	—	2.0 (0.08)
Wheel axle runout	Front	—	0.25 (0.010)
	Rear	—	0.25 (0.010)
Tire size	Front	110/70-17 54H	—
	Rear	140/70-17 66H	—
Tire tread depth	Front	—	1.6 (0.06)
	Rear	—	2.0 (0.08)

**SUSPENSION**

Unit: mm (in)

ITEM	STANDARD	LIMIT	NOTE
Front fork stroke	130 (5.1)	—	
Front fork spring free length	—	274 (10.8)	
Front fork oil level	90 (3.5)	—	
Rear wheel travel	122 (4.8)	—	
Swingarm pivot shaft runout	—	0.3 (0.01)	

**TIRE PRESSURE**

COLD INFLATION TIRE PRESSURE	SOLO RIDING			DUAL RIDING		
	kPa	kg/cm <sup>2</sup>	psi	kPa	kg/cm <sup>2</sup>	psi
FRONT	200	2.00	29	200	2.00	29
REAR	225	2.25	33	250	2.50	36

## FUEL + OIL + COOLANT

ITEM	SPECIFICATION		NOTE
Fuel type	Gasoline used should be graded 85-95 octane or higher. An unleaded gasoline is recommended.		
Fuel tank including reserve	12 L (3.2/2.6 US/Imp gal)		
reserve	2.0 L (0.5/0.4 US/Imp gal)		
Engine oil type	SAE 10W/40, API SE or SF		
Engine oil capacity	Change	2 600 ml (2.7/2.3 US/Imp qt)	
	Filter change	2 900 ml (3.1/2.6 US/Imp qt)	
	Overhaul	3 200 ml (3.4/2.8 US/Imp qt)	
Front fork oil type	Fork oil # 10		
Front fork oil capacity (each leg)	401 ml (13.6/14.1 US/Imp oz)		
Brake fluid type	DOT4		
Coolant type	Use an anti-freeze/coolant compatible with aluminum radiator, mixed with distilled water only, at the ratio of 50 : 50.		
Coolant including reserve	2 000 ml (2.1/1.8 US/Imp qt)		

FUEL + OIL + COOLANT

SERVICING INFORMATION	NOTE

Prepared by  
**SUZUKI MOTOR CORPORATION**  
Motorcycle Technical Service Department  
March, 1991  
Part No.: 99500-32060-01E  
Printed in Japan

**SUZUKI MOTOR CORPORATION**

*M*

Printed in Japan