

**SUZUKI**

**GSXR400**

**SERVICE MANUAL**

99500-33000-01E

(英)

# FOREWORD

*The SUZUKI GSX-R400 has been developed as a new generation motorcycle to the GSX-models. It is packed with highly advanced design concepts including a liquid cooling system, a new highly efficient combustion system (TSCC), a fully transistorized ignition system, an anti-dive device and a full-floater suspension system. Combined with precise control and easy handling the GSX-R400 provides excellent performance and outstanding riding comfort.*

*This service manual has been produced primarily for experienced mechanics whose job is to inspect, adjust, repair and service SUZUKI motorcycles. Apprentice mechanics and do-it-yourself mechanics, will also find this manual an extremely useful guide.*

*Model GSX-R400 manufactured to standard specifications is the main subject matter of this manual. However, the GSX-R400 machines distributed in your country might differ in minor respects from the standard-specification and, if they do, it is because some minor modifications (which are of no consequence in most cases as far as servicing is concerned) had to be made to comply with the statutory requirements of your country.*

*This manual contains up-to-date information at the time of its issue. Later made modifications and changes will be explained to each SUZUKI distributor in respective markets, to whom you are kindly requested to make query about updated information, if any.*

## **SUZUKI MOTOR CORPORATION**

*Motorcycle Technical Service Department  
Motorcycle Service Division*

VIEW OF SUZUKI GSX-R400

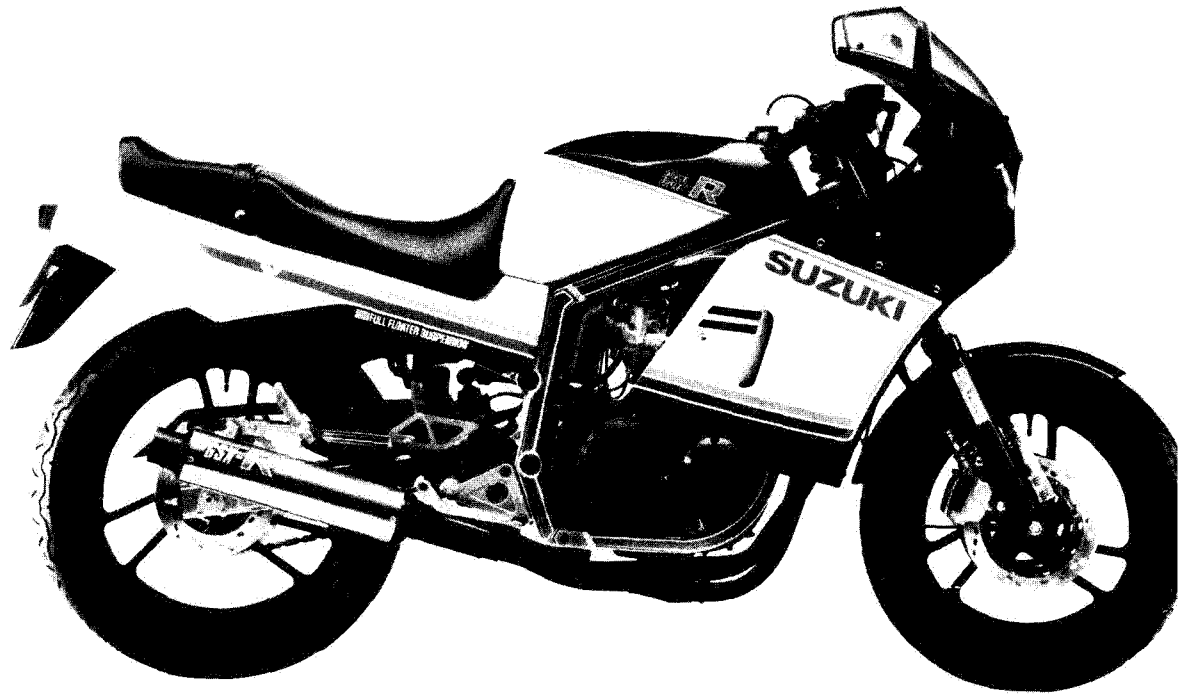

RIGHT SIDE

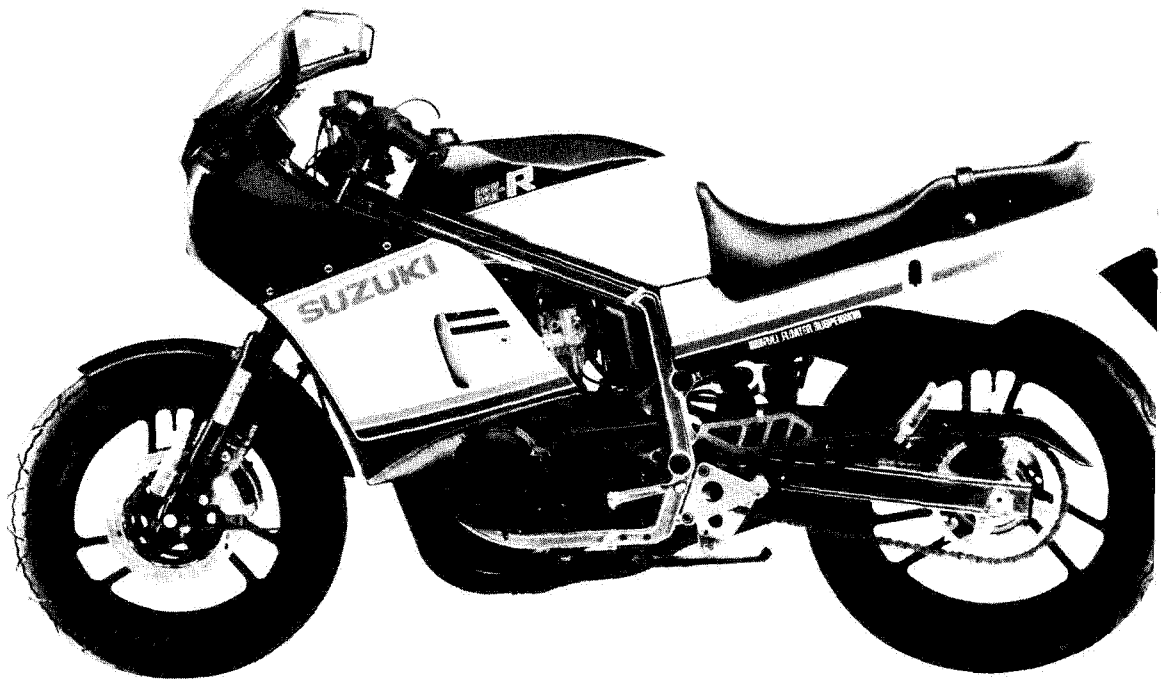

LEFT SIDE

## **GROUP INDEX**

<b>GENERAL INFORMATION</b>	<b>1</b>
<b>PERIODIC MAINTENANCE AND TUNE-UP PROCEDURES</b>	<b>2</b>
<b>ENGINE</b>	<b>3</b>
<b>FUEL AND LUBRICATION SYSTEM</b>	<b>4</b>
<b>COOLING SYSTEM</b>	<b>5</b>
<b>ELECTRICAL SYSTEM</b>	<b>6</b>
<b>CHASSIS</b>	<b>7</b>
<b>SERVICING INFORMATION</b>	<b>8</b>

# GENERAL INFORMATION

1

## CONTENTS

<b>SERIAL NUMBER LOCATION</b> .....	<b>1- 1</b>
<b>FUEL, OIL AND COOLANT RECOMMENDATION</b> .....	<b>1- 1</b>
<b>BREAKING-IN PROCEDURES</b> .....	<b>1- 2</b>
<b>CYLINDER IDENTIFICATION</b> .....	<b>1- 2</b>
<b>SPECIAL MATERIALS</b> .....	<b>1- 3</b>
<b>PRECAUTION AND GENERAL INSTRUCTION</b> .....	<b>1- 5</b>
<b>SPECIFICATIONS</b> .....	<b>1- 6</b>

## SERIAL NUMBER LOCATION

The frame serial number or V.I.N. (Vehicle identification Number) ① is stamped on the steering head pipe. The engine serial number ② is located on the right side of the crankcase. These numbers are required especially for registering the machine and ordering spare parts.

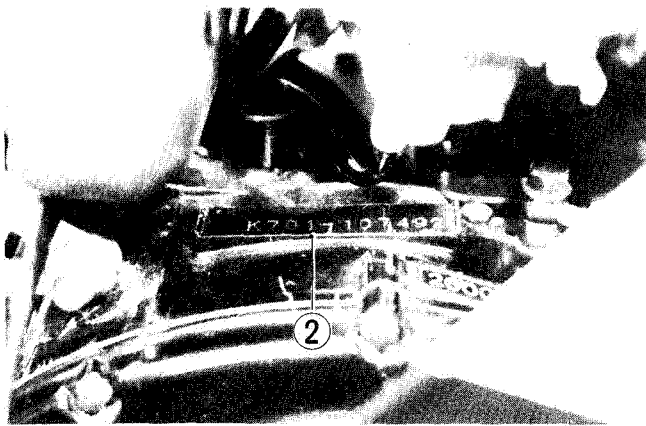
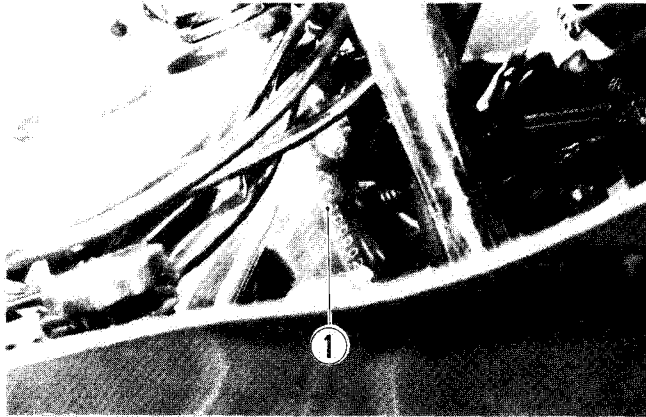

## FUEL, OIL AND COOLANT RECOMMENDATION

### FUEL

Gasoline used should be graded 85 – 95 octane or higher. An unleaded or low-lead gasoline type is recommended.

### ENGINE OIL

Be sure that the engine oil you use comes under API classification of SE or SF and that its viscosity rating is SAE 10W/40. If SAE 10W/40 motor oil is not available, select the oil viscosity according to the following chart:

SAE								
40							██████████	
30						██████████		
20W/50						██████████	██████████	
10W/50						██████████	██████████	
10W/30						██████████	██████████	
20W						██████████		
10W						██████████		
Temp.	°C	-20	-10	0	10	20	30	40
	°F	-4	14	32	50	68	86	104

## BRAKE FLUID

Specification and classification:	SAE J1703, DOT3 or DOT4
99000-23021	SUZUKI Brake fluid

### WARNING:

- \* Since the brake system of this motorcycle is filled with a glycol-based brake fluid by the manufacturer, do not use or mix different types of fluid such as silicone-based and petroleum-based fluid for refilling the system, otherwise serious damage will result.
- \* Do not use any brake fluid taken from old or used or unsealed containers.
- \* Never re-use brake fluid left over from the previous servicing and stored for a long period.

## FRONT FORK OIL

Use fork oil #15.

99000-99044-15G	SUZUKI fork oil #15
-----------------	---------------------

## COOLANT

Use an anti-freeze/coolant compatible with aluminum radiator, mixed with distilled water only, at the ratio of 50 : 50.

## WATER FOR MIXING

Use distilled water only. Water other than distilled water can corrode and clog the aluminum radiator.

## ANTI-FREEZE/COOLANT

The coolant performs as corrosion and rust inhibitor as well as anti-freeze. Therefore, the coolant should be used at all times even though the atmospheric temperature in your area does not go down to freezing point.

SUZUKI recommends the use of SUZUKI GOLDEN CRUISER 1 200 anti-freeze/coolant. If this is not available, use an equivalent which is compatible with aluminum radiator.

## REQUIRED AMOUNT OF WATER/COOLANT

Solution capacity (total): 2 185 ml

### CAUTION:

Mixing of anti-freeze/coolant should not exceed 60%. Mixing beyond it would reduce its efficiency. If the anti-freeze/coolant mixing ratio is below 50%, the rust inhibiting performance is greatly reduced. Be sure to mix the solution 50% even though the atmospheric temperature does not go down to freezing point.

Every new unit is filled with anti-leakage material, Bar's leak.

## BREAKING-IN PROCEDURES

During manufacture only the best possible materials are used and all machined parts are finished to a very high standard but it is still necessary to allow the moving parts to "BREAK-IN" before subjecting the engine to maximum stresses. The future performance and reliability of the engine depends on the care and restraint exercised during its early life. The general rules are as follows:

- Keep to these breaking-in engine speed limits:

Initial	800 km	Below	4 000 r/min
Up to	1 600 km	Below	6 000 r/min
Over	1 600 km	Below	12 000 r/min

- Upon reaching an odometer reading of 1 600 km you can subject the motorcycle to full throttle operation. However, do not exceed 12 000 r/min at any time.

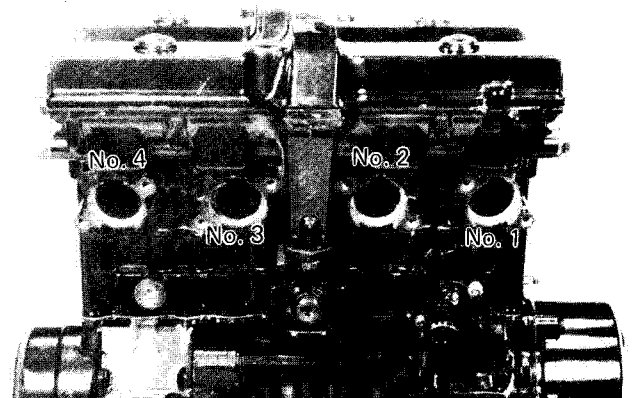

## CYLINDER IDENTIFICATION

The four cylinders of this engine are identified as No. 1, No. 2, No. 3 and No. 4 cylinder, as counted from left to right (as viewed by the rider on the seat).





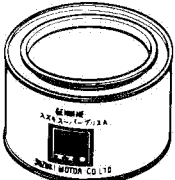
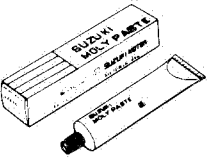
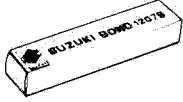

## SPECIAL MATERIALS

The materials listed below are needed for maintenance work on the GSX-R400, and should be kept on hand for ready use. They supplement such standard materials as cleaning fluids, lubricants, emery cloth and the like. HOW to use them and where to use them are described in the text of this manual.

Material	Part	Page	Part	Page
 <p>SUZUKI SUPER GREASE "A" 99000-25010</p>	<ul style="list-style-type: none"> <li>• Oil seals</li> <li>• Wheel bearings</li> <li>• Steering stem bearings</li> <li>• Cushion lever bearing</li> <li>• Cushion rod bearing</li> <li>• Swing arm bearing and dust seal</li> </ul>	<p>3-53 7- 6 7-25 7-54 7-54 7-55</p>		
 <p>SUZUKI MOLY PASTE 99000-25140</p>	<ul style="list-style-type: none"> <li>• Valve stem</li> <li>• Conrod big end bearing</li> <li>• Countershaft</li> <li>• Crankshaft journal bearing</li> <li>• Cam shaft journal</li> </ul>	<p>3-28 3-38 3-49 3-52 3-64</p>		
 <p>SUZUKI BOND No. 1207B 99000-31140</p>	<ul style="list-style-type: none"> <li>• Mating surfaces of upper and lower crankcase</li> <li>• Mating surface of crankcase and clutch cover, generator cover</li> <li>• Cylinder head cover gasket</li> </ul>	<p>3-53 3-56 3-60 3-68</p>	<ul style="list-style-type: none"> <li>• Engine thermo-switch</li> <li>• Water temperature gauge</li> </ul>	<p>3-68 5-12 5-14</p>
 <p>SUZUKI BRAKE FLUID 99000-23021 (0.5L)</p>	<ul style="list-style-type: none"> <li>• Brake fluid</li> </ul>			
 <p>SUZUKI GOLDEN CRUISER 1200 (2L) 99000-24120</p>	<ul style="list-style-type: none"> <li>• Coolant</li> </ul>			



Material	Part	Page	Part	Page
 <p>THREAD LOCK SUPER "1303" 99000-32030</p>	<ul style="list-style-type: none"> <li>• Cam sprocket bolt</li> <li>• Starter clutch allen bolt</li> <li>• Gearshift cam retainer screw</li> </ul>	<p>3-31 3-46 3-57</p>		
 <p>THREAD LOCK "1342" 99000-32050</p>	<ul style="list-style-type: none"> <li>• Cam chain guide screw</li> <li>• Generator stator securing screw</li> <li>• Generator lead wire guide screw</li> <li>• Gearshift fork shaft stopper screw</li> <li>• Gearshift cam guide bolt</li> <li>• Oil sump filter screw</li> </ul>	<p>3-32 3-46 3-46 3-51 3-51 3-54</p>	<ul style="list-style-type: none"> <li>• Starter motor mounting bolt</li> <li>• Gearshift cam stopper bolt</li> <li>• Countershaft bearing retainer screw</li> <li>• Throttle valve screw</li> <li>• Carburetor bracket screw</li> <li>• Starter motor housing screw</li> <li>• Anti-Dive modulator valve fitting bolt</li> <li>• Front fork damper rod bolt</li> </ul>	<p>3-56 3-57 3-57 4-11 4-12 6-10 7-20 7-20</p>
 <p>THREAD LOCK SUPER "1305" 99000-32100</p>	<ul style="list-style-type: none"> <li>• Generator rotor bolt</li> </ul>	<p>3-56</p>		
<p>SUZUKI BAR's LEAK 99000-24240</p>				
 <p>THREAD LOCK "1360" 99000-32130</p>	<ul style="list-style-type: none"> <li>• Disc mounting bolt</li> </ul>	<p>7-7</p>		

## PRECAUTION AND GENERAL INSTRUCTION

Observe the following items without fail when servicing, disassembling and reassembling motorcycles.

- Do not run engine indoors with little or no ventilation.
- Be sure to replace packings, gaskets, circlips, O rings and cotter pins with new ones.

### CAUTION:

Never reuse a circlip after a circlip has been removed from a shaft, it should be discarded and a new circlip must be installed.

When installing a new circlip, care must be taken not to expand the end gap larger than required to slip the circlip over the shaft.

After installing a circlip, always insure that it is completely seated in its groove and securely fitted.

- Tighten cylinder head and case bolts and nuts beginning with larger diameter and ending with smaller diameter, and from inside to out-side diagonally, to the specified tightening torque.
- Use special tools where specified.
- Use genuine parts and recommended oils.
- When 2 or more persons work together, pay attention to the safety of each other.
- After the reassembly, check parts for tightness and operation.
- Treat gasoline, which is extremely flammable and highly explosive, with greatest care. Never use gasoline as cleaning solvent.

Warning, Caution and Note are included in this manual occasionally, describing the following contents.

**WARNING** . . . . . When personal safety of the rider is involved, disregard of the information could result in injury.

**CAUTION** . . . . . For the protection of the motorcycle, the instruction or rule must be strictly adhered to.

**NOTE** . . . . . Advice calculated to facilitate the use of the motorcycle is given under this heading.

### USE OF GENUINE SUZUKI PARTS

To replace any part of the machine, use a genuine SUZUKI replacement part. Imitation parts or parts supplied from any other source than SUZUKI, if used to replace SUZUKI parts can reduce the machine's performance and, even worse, could induce costly mechanical troubles.

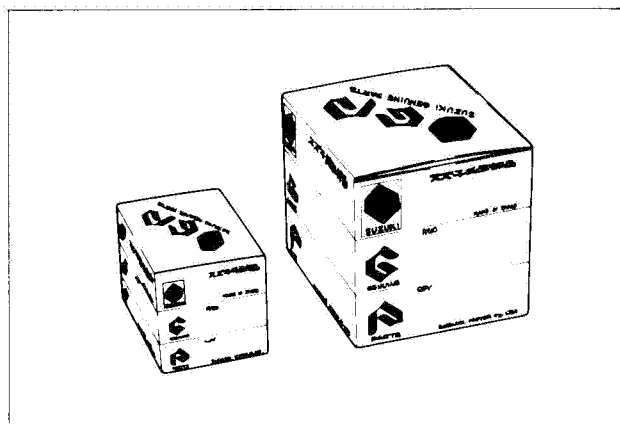

## SPECIFICATIONS

### DIMENSIONS AND DRY MASS

Overall length .....	2 090 mm
Overall width .....	710 mm
Overall height .....	1 185 mm
Wheelbase .....	1 425 mm
Ground clearance .....	135 mm
Dry mass .....	157 kg

### ENGINE

Type .....	Four-stroke, water-cooled, DOHC
Number of cylinders .....	4
Bore .....	53.0 mm
Stroke .....	45.2 mm
Piston displacement .....	398 cm <sup>3</sup>
Compression ratio .....	11.3 : 1
Carburetor .....	AISAN AS27VW, twin
Air cleaner .....	Polyurethane foam element
Starter system .....	Electric
Lubrication system .....	Wet sump

### TRANSMISSION

Clutch .....	Wet multi-plate type
Transmission .....	6-speed constant mesh
Gearshift pattern .....	1-down, 5-up
Primary reduction .....	2.212 (104/47)
Final reduction .....	3.066 (46/15)
Gear ratios, Low .....	3.166 (38/12)
2nd .....	2.125 (34/16)
3rd .....	1.631 (31/19)
4th .....	1.333 (28/21)
5th .....	1.173 (27/23)
Top .....	1.083 (26/24)
Drive chain .....	DAIDO DID525V or TAKASAGO RK525SM, 114 links

**CHASSIS**

Front suspension .....	Telescopic, coil spring, oil dampened with ANTI-DIVE
Rear suspension .....	Full-floating suspension system, spring pre-load fully adjustable, oil dampened
Steering angle .....	30° (right & left)
Caster .....	62° 35'
Trail .....	96 mm
Turning radius .....	3.3 m
Front brake .....	Disc brake, twin
Rear brake .....	Disc brake
Front tire size .....	100/90-16 54H
Rear tire size .....	110/90-18 61H
Front fork stroke .....	130 mm
Rear wheel travel .....	124 mm

**ELECTRICAL**

Ignition type .....	Fully transistorized
Ignition timing .....	15° B.T.D.C. below at 1 650 r/min and 35° B.T.D.C. above 3 500 r/min
Spark plug .....	N.D.: U24FS-U NGK: C8HA
Battery .....	12V 39.6 kC (11 Ah)/10HR
Generator .....	Three-phase A.C. generator
Fuse .....	20A

**CAPACITIES**

Fuel tank including reserve .....	18 L
Reserve .....	3.5 L
Engine oil .....	2.6 L
Front fork oil (each leg) .....	397 ml
Cooling solution .....	2 185 ml

\* These specifications are subject to change without notice.

# PERIODIC MAINTENANCE AND TUNE-UP PROCEDURES

## CONTENTS

<b>PERIODIC MAINTENANCE SCHEDULE</b> .....	<b>2- 1</b>
<b>PERIODIC MAINTENANCE CHART</b> .....	<b>2- 1</b>
<b>LUBRICATION POINTS</b> .....	<b>2- 2</b>
<b>MAINTENANCE AND TUNE-UP PROCEDURES</b> .....	<b>2- 3</b>
<b>AIR CLEANER ELEMENT</b> .....	<b>2- 3</b>
<b>BATTERY</b> .....	<b>2- 4</b>
<b>CYLINDER HEAD NUTS AND EXHAUST PIPE BOLTS</b> .....	<b>2- 5</b>
<b>VALVE CLEARANCE</b> .....	<b>2- 6</b>
<b>SPARK PLUGS</b> .....	<b>2- 8</b>
<b>CARBURETORS</b> .....	<b>2- 9</b>
<b>FUEL LINES</b> .....	<b>2- 9</b>
<b>ENGINE OIL AND FILTER</b> .....	<b>2-10</b>
<b>CLUTCH</b> .....	<b>2-11</b>
<b>COOLANT AND RADIATOR HOUSES</b> .....	<b>2-11</b>
<b>DRIVE CHAIN</b> .....	<b>2-13</b>
<b>BRAKES</b> .....	<b>2-14</b>
<b>TIRES</b> .....	<b>2-17</b>
<b>STEERING</b> .....	<b>2-18</b>
<b>FRONT FORK</b> .....	<b>2-18</b>
<b>CHASSIS BOLTS AND NUTS</b> .....	<b>2-19</b>

## PERIODIC MAINTENANCE SCHEDULE

The chart below lists the recommended intervals for all the required periodic service work necessary to keep the motorcycle operating at peak performance and economy. Mileages are expressed in terms of kilometers.

**NOTE:**

More frequent servicing may be performed on motorcycles that are used under severe conditions.

### PERIODIC MAINTENANCE CHART

Item	Interval	1 000	6 000	12 000	18 000	24 000	
	km months	2	12	24	36	48	
Air cleaner	Clean every 3 000 km						
Battery (Specific gravity of electrolyte)		—	I	I	I	I	
Cylinder head nuts and exhaust pipe bolts		T	T	T	T	T	
Valve clearance		I	I	I	I	I	
Spark plug		—	C	R	C	R	
Carburetor		I	I	I	I	I	
Fuel line		I	I	I	I	I	
	Replace every 4 years						
Engine oil and oil filter		R	R	R	R	R	
Clutch		I	I	I	I	I	
Radiator hose		I	—	I	—	I	
	Replace every 4 years						
Coolant		Replace every 2 years					
Drive chain		I	I	I	I	I	
	Clean and lubricate every 1 000 km						
Brake		I	I	I	I	I	
Brake hose		I	I	I	I	I	
	Replace every 4 years						
Brake fluid		Replace every 2 years					
Tire		I	I	I	I	I	
Steering		I	I	I	I	I	
Front fork		I	—	I	—	I	
Chassis bolts and nuts		T	T	T	T	T	

NOTE: T = Tighten, I = Inspect, R = Replace, C = Clean

### LUBRICATION POINTS

Proper lubrication is important for smooth operation and long life of each working part of the motorcycle and also for safe riding. It is good maintenance to oil the machine after along rough ride and after getting it wet in the rain or after washing it. Major oiling points are indicated below.

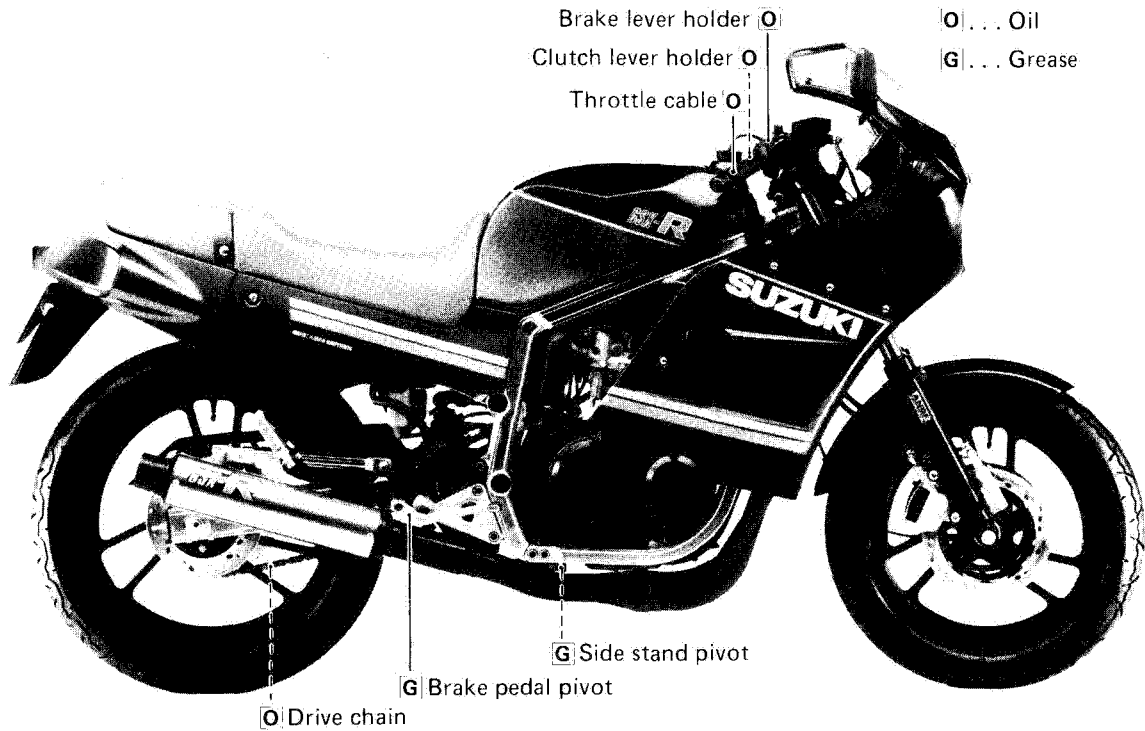

## MAINTENANCE AND TUNE-UP PROCEDURES

This section describes the servicing procedures for each item of the Periodic Maintenance requirements.

### AIR CLEANER

Clean Every 3 000 km

If the air cleaner is clogged with dust, intake resistance will be increased with a resultant decrease in output and an increase in fuel consumption. Check and clean the element in the following manner.

- Remove the fuel tank.
- Loosen the two screws ① and remove the air cleaner case cover.
- Separate the element holder from the element.
- Take out the element.
- Fill a washing pan of a proper size with non-flammable cleaning solvent. Immerse the element in the cleaning solvent and wash it clean.
- Squeeze the cleaning solvent out of the washed element by pressing it between the palms of both hands: do not twist or wring the element or it will develop tears.
- Immerse the element in motor oil, and squeeze the oil out of the element leaving it slightly wet with oil.
- Fit the cleaner element to frame properly.

#### CAUTION:

- \* Before and during the cleaning operation, inspect the element for tears. A torn element must be replaced.
- \* Be sure to position the element snugly and correctly, so that no incoming air will bypass it. Remember, rapid wear or piston rings and cylinder bore is often caused by a defective or poorly fitted element.

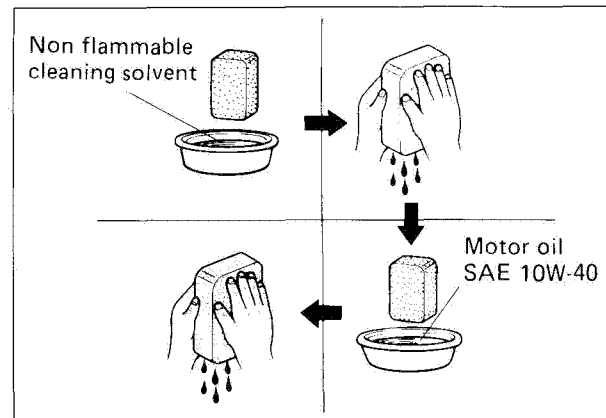
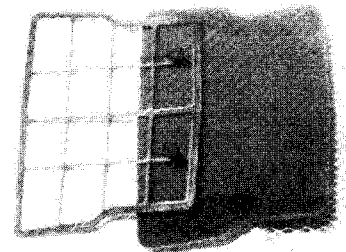
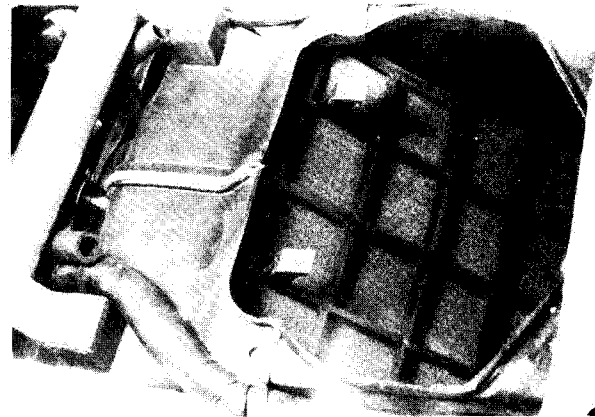
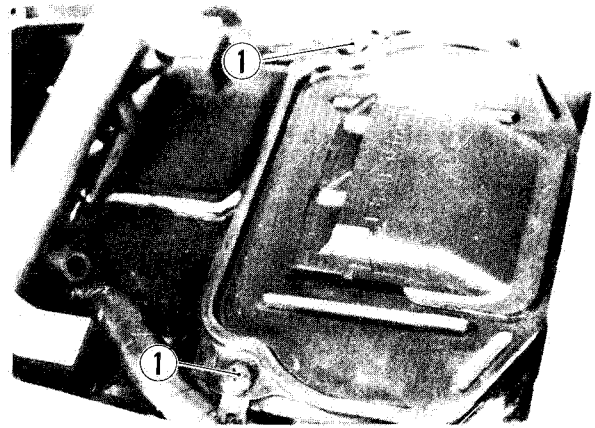



## BATTERY

Inspect Every 6 000 km

- Remove the seat.
- Remove battery  $\ominus$  lead at the battery terminal.
- Remove battery  $\oplus$  lead at the battery terminal.
- Remove battery from the frame.
- Check electrolyte for level and specific gravity. Add distilled water, as necessary, to keep the surface of the electrolyte above the MIN. level line but not above the MAX. level line.

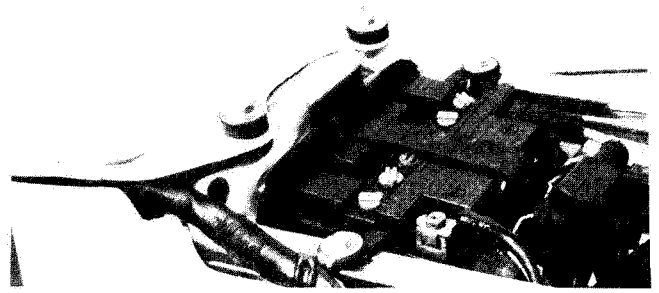

For checking specific gravity, use a hydrometer to determine the charged condition.

09900-28403	Hydrometer
-------------	------------

Standard specific gravity	1.28 at 20 °C (68 °F)
---------------------------	-----------------------

An S.G. reading of 1.22 (at 20 °C) or under means that the battery needs recharging off the machine: take it off and charge it from a recharger. Charging the battery in place can lead to failure of the regulator/rectifier.

- To install the battery, reverse the procedure described above.

**WARNING:**

When installing the battery lead wires, fix the  $\oplus$  lead first and  $\ominus$  lead last.

- Make sure that the breather pipe is tightly secured and undamaged, and is routed as shown in the figure.

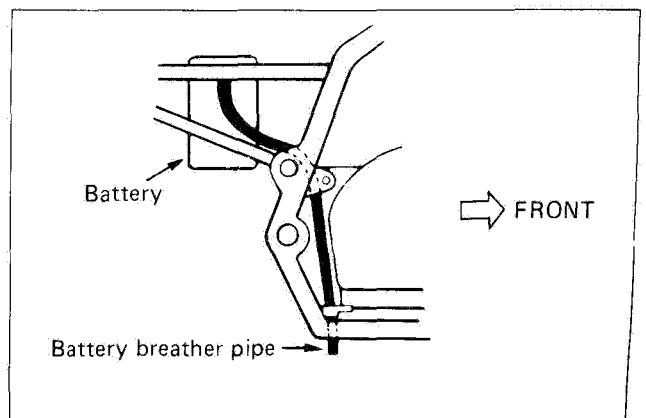
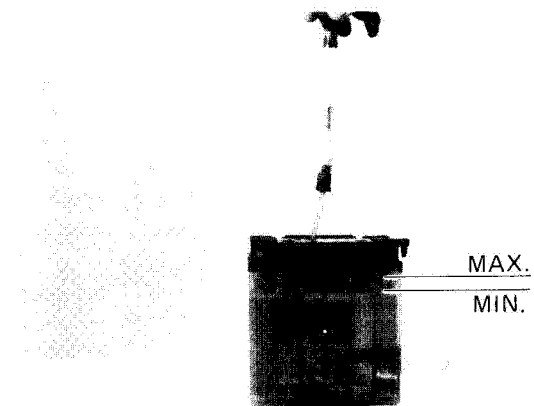

## CYLINDER HEAD NUTS AND EXHAUST PIPE BOLTS

Retighten Initial 1 000 km and  
Every 6 000 km

### CYLINDER HEAD

- Remove the seat and fuel tank.
- Remove the fairing.
- Drain coolant, and remove the radiator and inlet hose.
- Remove the electrical fan.
- Remove the cylinder head cover.
- Tighten the twelve 8 mm nuts (12 mm wrench) to the specified torque with a torque wrench sequentially in ascending numerical order with the engine cold.

Cylinder head nut	25 – 29 N·m (2.5 – 2.9 kg·m)
-------------------	---------------------------------

- After firmly tightening the 12 nuts, tighten the 6 mm bolt (indicated as (A)) to the torque value below.

Head bolt	8 – 12 N·m (0.8 – 1.2 kg·m)
-----------	--------------------------------

### NOTE:

Apply Bond No. 1207B to cylinder head cover groove and four camshaft end seals.

### EXHAUST PIPE

- Tighten the exhaust pipe bolts to the specified torque with a torque wrench.

Exhaust pipe bolt	9 – 12 N·m (0.9 – 1.2 kg·m)
-------------------	--------------------------------

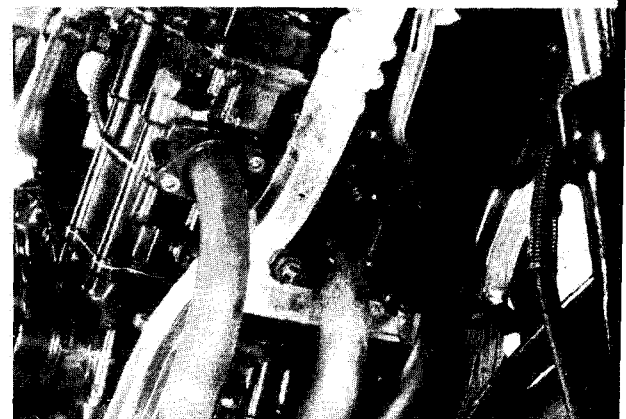
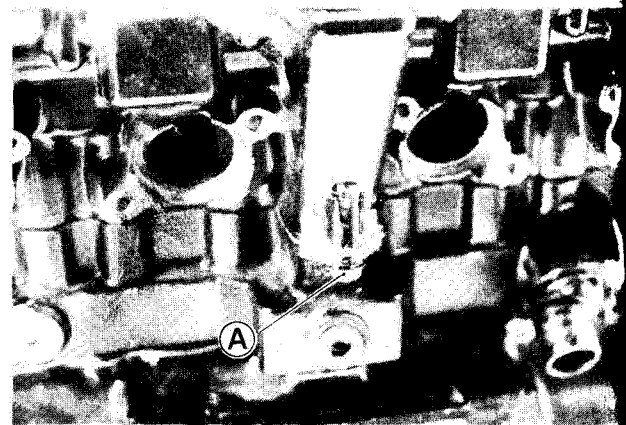
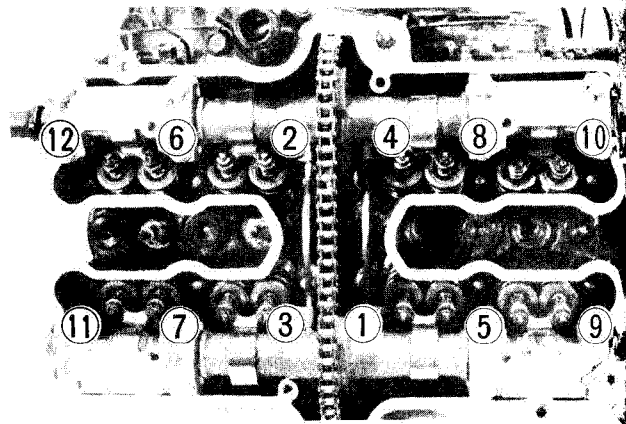

## VALVE CLEARANCE

Inspect Initial 1 000 km and  
Every 6 000 km

The valve clearance specification is the same for both intake and exhaust valves.

Valve clearance adjustment must be checked and adjusted 1) at the time of periodic inspection, 2) when the valve mechanism is serviced, and 3) when the camshafts are disturbed by removing them for servicing.

Valve clearance (when cold)	0.13 – 0.18 mm
--------------------------------	----------------

**NOTE:**

- \* The cam must be at position **A** or **B** in order to check the valve clearance or to adjust valve clearance. Clearance readings should not be taken with the cam in any other position than these two positions.
- \* The clearance specification is for COLD state.
- \* To turn the crankshaft for clearance checking, be sure to use a 19-mm wrench and to rotate in the normal running direction. All spark plugs should be removed.

- Turn crankshaft to bring the "T" mark on the signal generator rotor to the timing mark of the Nos. 1 and 4 signal coil, and also to bring the notches **①** in the right ends of both camshafts (Ex and In) to the positions shown. In this condition, read the valve clearance at the valves **©** (In and Ex of No. 1 cylinder, Ex of No. 2 and In of No. 3).

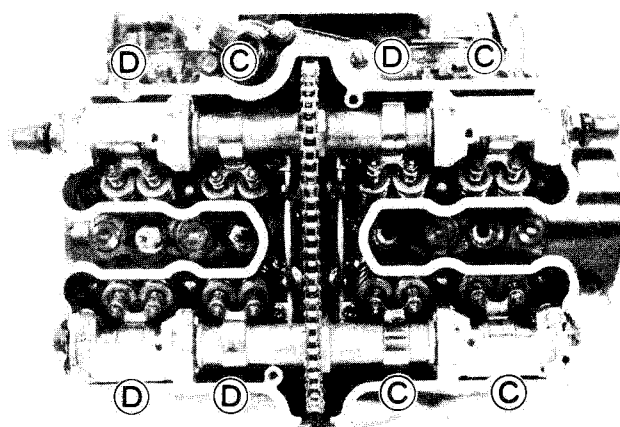
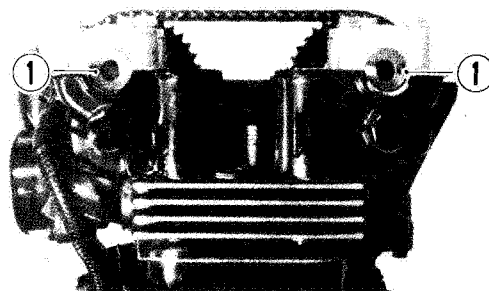
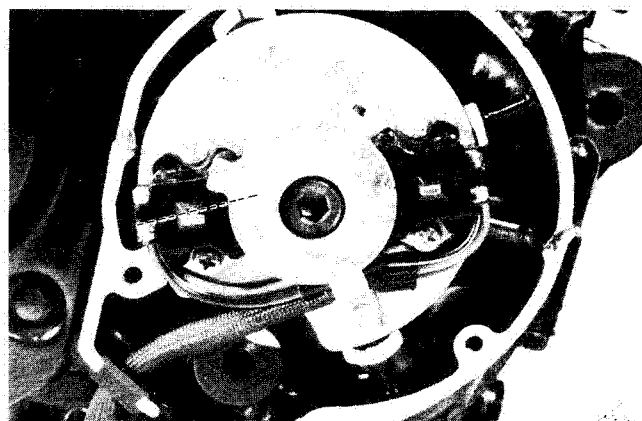
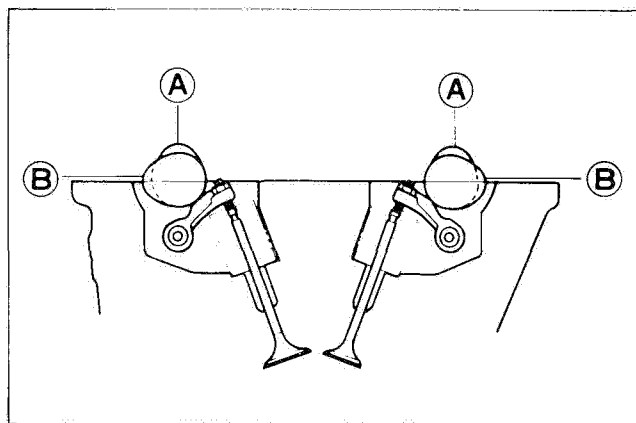

- Use a thickness gauge between the tappet and valve. If the clearance is off the specification, bring it into the specified range by using the tappet adjusting driver ②.

09900-20806	Thickness gauge
09917-14910	Tappet adjust driver

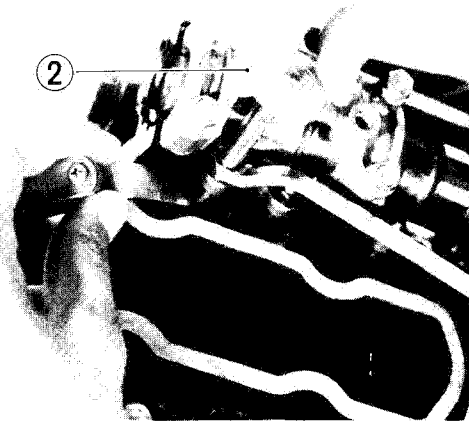

- Turn the crankshaft 360° (one rotation) to bring the "T" mark to the timing mark of Nos. 1 and 4 signal generator coil, and also to bring the notches ① to the positions shown.
- Rear the clearance at the valve ③ and adjust the clearance if necessary.

**CAUTION:**

Both the right and left valve clearances, should be as closely set as possible.

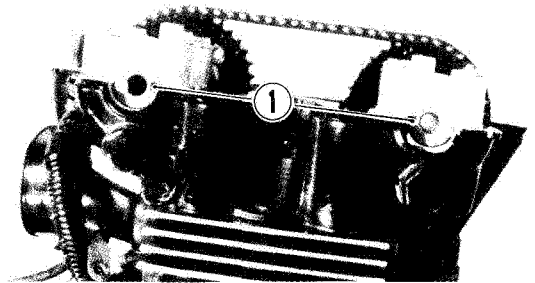

- Tighten the cylinder head cover properly.

**NOTE:**

Apply Bond No. 1207B to head cover groove and four camshaft end seals.

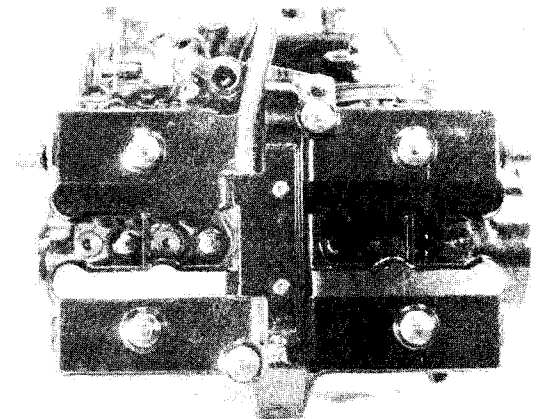

## SPARK PLUGS

Clean and Adjust Every 6 000 km  
 Replace Every 12 000 km

The plug gap is adjusted to 0.6 – 0.7 mm. The gap is correctly adjusted by using a thickness gauge (special tool). When carbon is deposited on the spark plug, remove the carbon with a spark plug cleaning machine or carefully using tool with a pointed end. If the electrodes are extremely worn, replace the plug. Also replace the plug if it has a broken insulator, damaged thread etc.

NGK C8HA or NIPPON DENSO U24ES-U as listed in the table should be used as the standard plug. However, the heat range of the plug should be selected to meet the requirements of speed, actual load, fuel, etc. If the plugs need to be replaced, it is recommended that the standard plugs listed in the table be selected. Remove the plugs and inspect the insulators. Proper heat range would be indicated if all insulators were light brown in color. If they are blackened by carbon, they should be replaced by a hot type NGK C7HA or NIPPON DENSO U22FS-U.

**NOTE:**  
 To check the spark plugs, first make sure that the fuel tank contains unleaded gasoline, and after a test ride, if the plugs are either sooty with carbon replace them altogether.

**NOTE:**  
 Confirm the thread size and reach when replacing the plug. If the reach is too short, carbon will be deposited on the screw portion of the plug hole and engine damage may result.

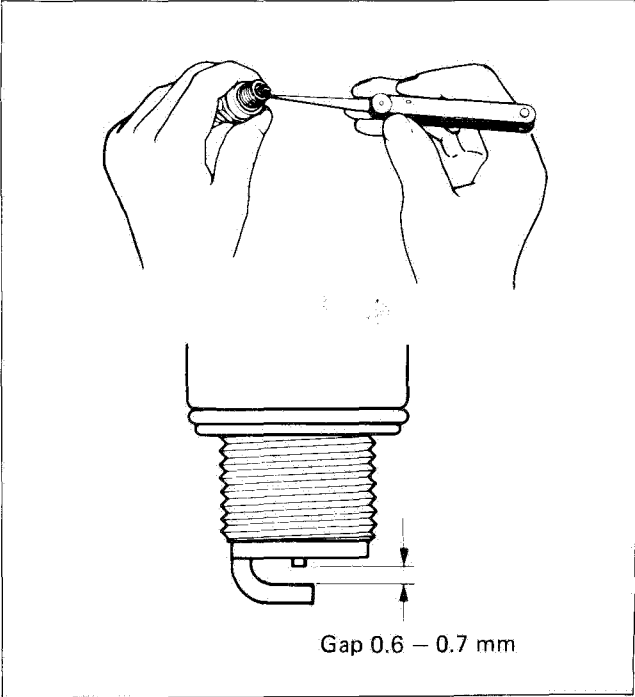

NGK	NIPPON DENSO	REMARKS
C7HA	U22FS-U	If the standard plug is apt to get wet, replace with this plug. Hot type.
C8HA	U24FS-U	Standard

## CARBURETORS

Inspect Initial 1 000 km and  
Every 6 000 km

### IDLING ADJUSTMENT

#### NOTE:

Make this adjustment when the engine is hot.

- Start up the engine and set its speed at anywhere between 1 200 and 1 400 r/min by turning throttle stop screw ①.

Engine idle speed	1 300 ± 100 r/min
-------------------	-------------------

### THROTTLE CABLE PLAY

There should be 0.5 – 1.0 mm play ① on the throttle cable. To adjust the throttle cable play:

- Remove the seat and fuel tank.
- Tug on the throttle cable to check the amount of play.
- Loosen the lock nut ② and turn the adjuster ③ in or out until the specified play is obtained.
- Secure the lock nut while holding the adjuster in place.

Throttle cable play ①	0.5 – 1.0 mm
-----------------------	--------------

### CHOKE CABLE ADJUSTMENT

- Loosen the lock nut ④ and turn the adjuster ⑤ to adjust the cable play.
- Tighten the lock nuts and re-check cable play.

Choke cable play ②	0.5 – 1.0 mm
--------------------	--------------

### FUEL LINE

Replace Every 4 years

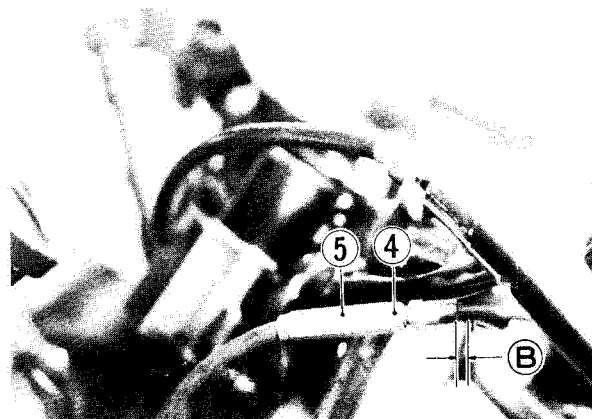
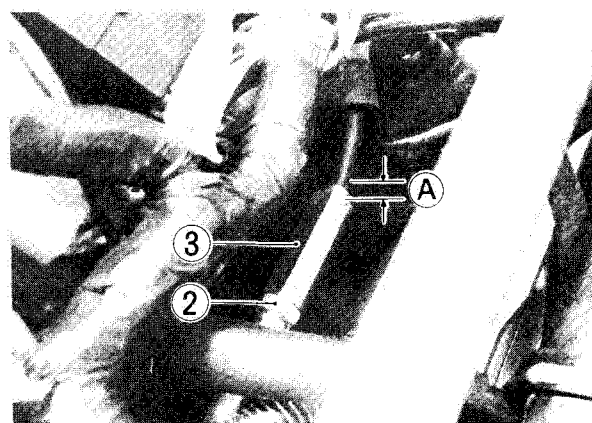
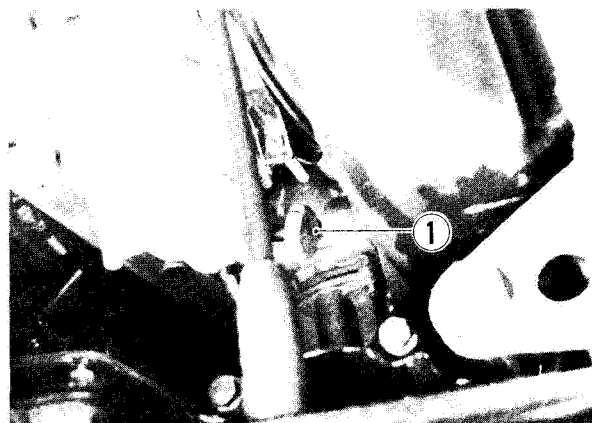

## ENGINE OIL AND OIL FILTER

Replace oil and oil filter Initial 1 000 km and Every 6 000 km

Oil should be changed while the engine is hot. Oil filter replacement at the above intervals should be done together with engine oil change.

- Keep the motorcycle upright.
- Place an oil pan under the engine and drain oil by removing the drain plug ① and filler cap ②.
- Remove three nuts ③ and remove the filter cover.
- Pull out old filter ④, and replace with new one.
- Replace O-ring and filter cover, and secure nuts ③ with applying thread lock "1342".

99000-32050

Thread lock "1342"

- Install the filter cap so that the oil pressure inspection bolt ⑤ is in top.
- Fit drain plug ① securely, and add fresh oil through the filler. The engine will hold about 3 000 ml of oil.  
Use API classification of SE or SF oil with SAE 10W/40 viscosity.
- Start up the engine and allow it to run for several seconds at idling speed.
- Turn off the engine and wait about one minute, then check the oil level through the inspection window ⑥. If the level is below mark "F", supply oil to that level.

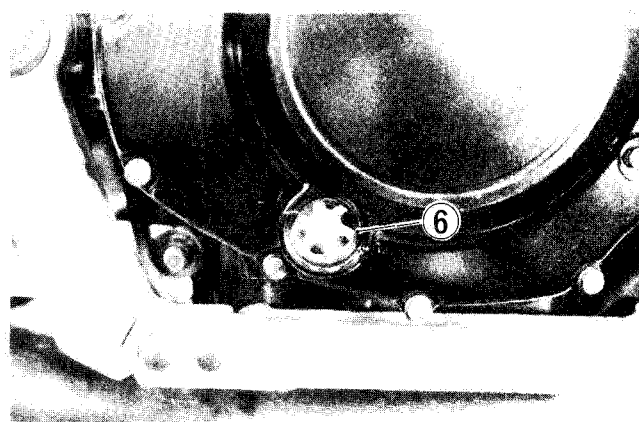
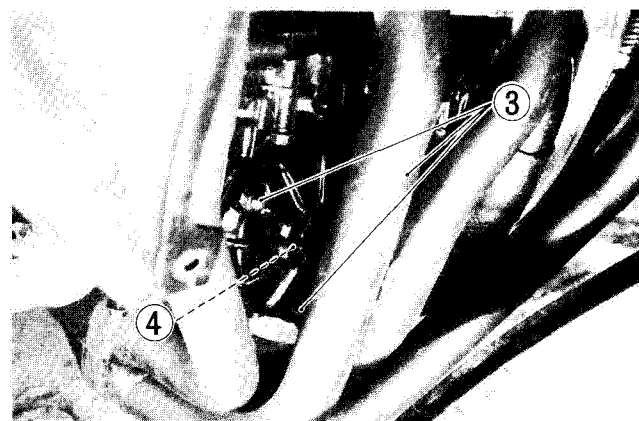
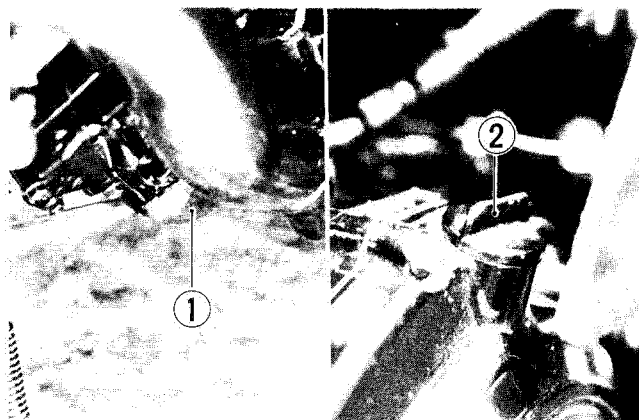

### NECESSARY AMOUNT OF ENGINE OIL

Oil change	2 600 ml
Filter change	3 000 ml
Overhaul engine	3 300 ml

#### NOTE:

Be sure to take care of O-ring ⑦ to prevent any damage and be sure that filter spring ⑧ is properly in place.

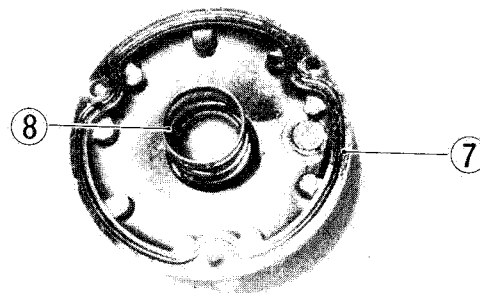

## CLUTCH

Inspect Initial 1 000 km and Every 6 000 km

- Remove the clutch inspection cap with 4 mm hexagon wrench.
- Loosen lock nut ① and reposition adjuster ② in place to introduce a necessary amount of play for the clutch lever.
- Loosen lock nut ③, and adjusting screw ④ away two to three rotations.
- From that position of adjusting screw, slowly run it in until it begin to feel high resistance to turning. From this position, back it away 1/4 – 1/2 rotation, and secure it by tightening lock nut ③.
- Set the adjuster ② to provide a clutch lever play A of 4 mm, and tighten the lock nut ①.

Clutch cable play A	4 mm
---------------------	------

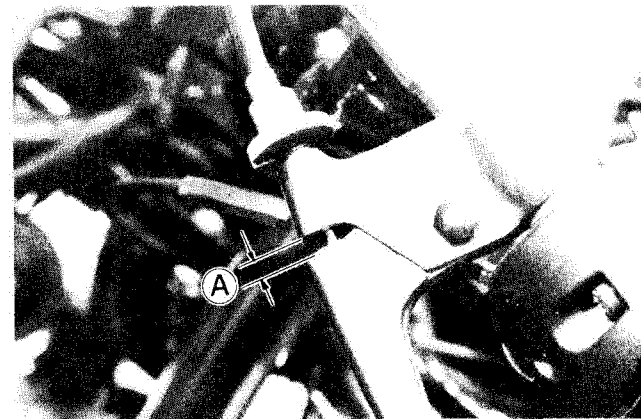
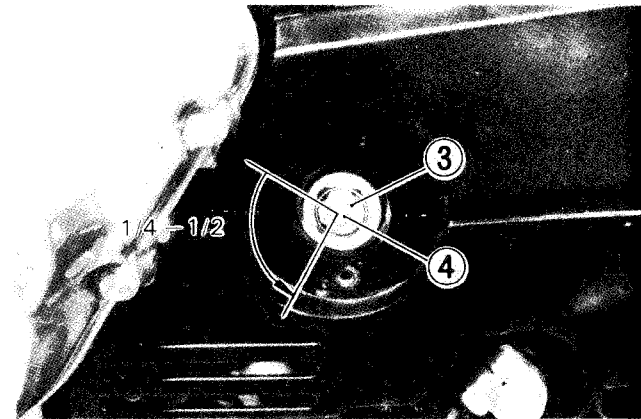
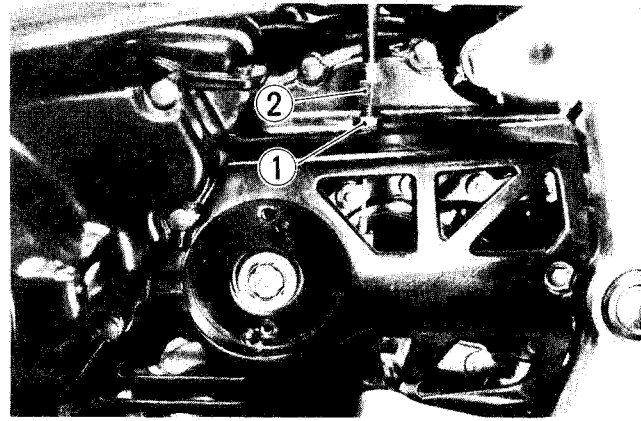

## COOLANT AND RADIATOR HOSES

Replace coolant Every 2 years  
 Replace hoses Every 4 years.  
 Inspect the radiator hoses  
 Initial 1 000 km and Every 12 000 km

- Remove the fairing.



- Remove the radiator cap ① and drain plug ②.

**WARNING:**

Do not open the radiator cap when the engine is hot, as you may be injured by escaping hot liquid or vapor.

**WARNING:**

Coolant may be harmful if swallowed or if it comes in contact with skin or eyes. Contact your physician immediately. If swallowed, induce vomiting. If coolant gets into the eyes or in contact with the skin, it should be flushed thoroughly with plenty of water.

- Flash the radiator with fresh water if necessary.
- Tighten the drain plug ② securely and loosen the air bleeder ③.
- Install the specified coolant up to the radiator inlet hole and tighten the air bleeder ③.

**NOTE:**

Mix coolant with distilled water only at the ratio 50:50.

- Close the radiator cap securely.
- Fill the reservoir tank above 4 mm to the "FULL" level with coolant.
- After warming up and cooling down the engine, check the coolant level of the reservoir tank and install the coolant to the "FULL" level if the level is below "FULL".

Necessary amount of cooling solution	2 185 ml
--------------------------------------	----------

- Add 2 pcs of anti-leakage material (Ber's leaks) in the coolant.

99000-24240	Bar's leak
-------------	------------

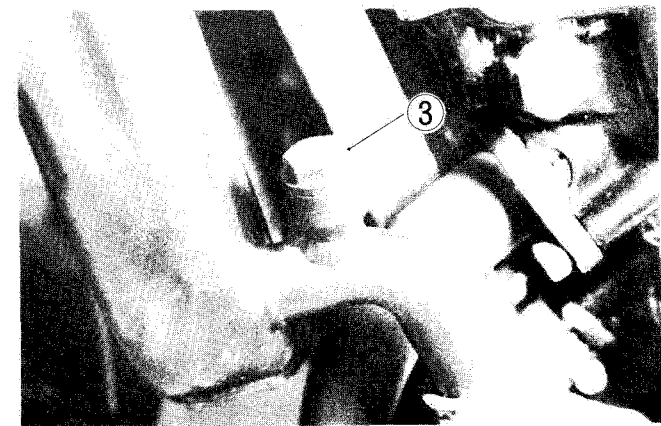
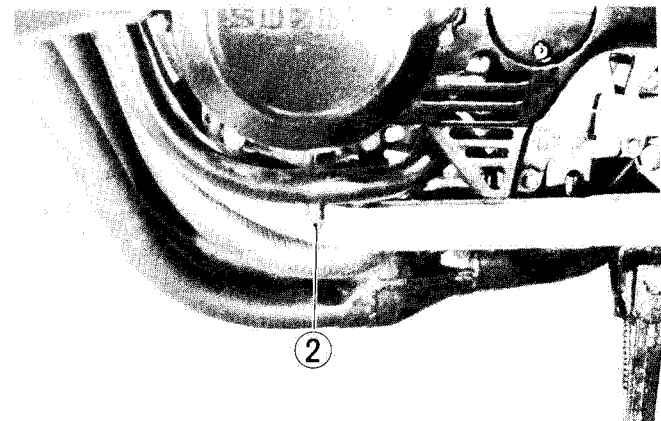
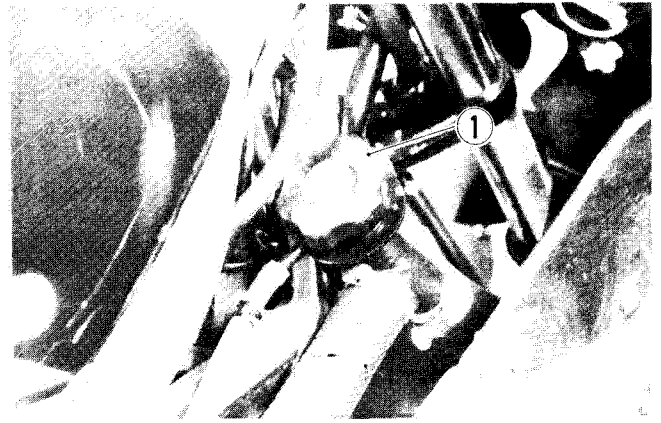

## DRIVE CHAIN

Inspect Initial 1 000 km and Every 6 000 km  
Clean and Lubricate Every 1 000 km

Visually inspect the drive chain for the possible defects listed below.

1. Loose pins
2. Damaged rollers
3. Rusted links
4. Twisted or seized links
5. Excessive wear

If any defects are found, the drive chain must be replaced.

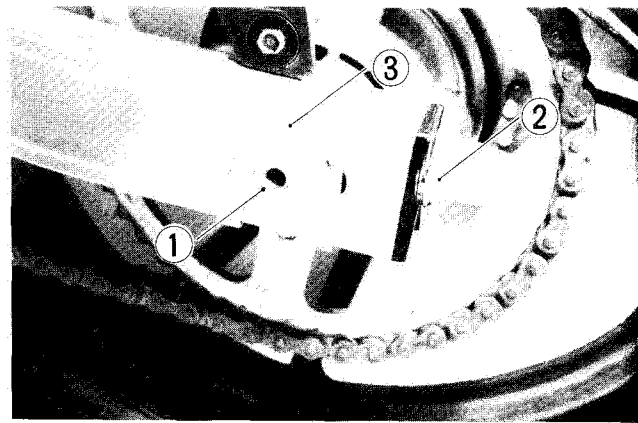

### CHECKING

- Loosen axle nut ①.
- Stretch the drive chain fully by tightening the adjusters ②.
- Remove the chain guard. Count out 21 pins (20-pitches) on the chain and measure the distance between the two. If the distance exceeds following limit, the chain must be replaced.

Service Limit	319.4 mm
---------------	----------

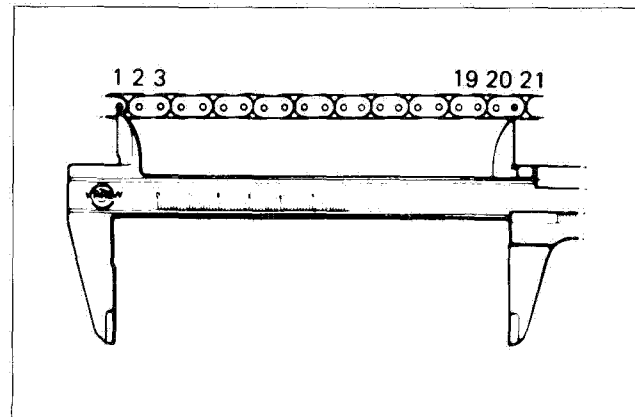

### ADJUSTING

- Loosen the adjuster ② until the chain has 20 – 30 mm of sag at the middle between engine and rear sprockets. The mark ③ on both chain adjusters must be at the same position on the scale to ensure that the front and rear wheels are correctly aligned.

Drive chain sag	20 – 30 mm
-----------------	------------

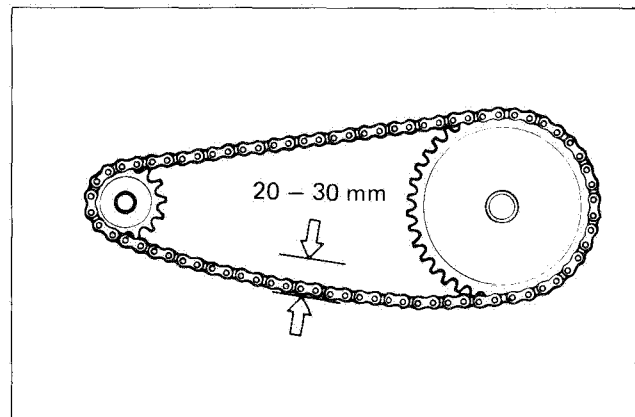

- After adjusting the drive chain, tighten the axle nut ① securely.

Rear axle nut tightening torque	50 – 80 N·m (5.0 – 8.0 kg·m)
---------------------------------	---------------------------------

### CLEANING AND LUBRICATION

Wash the chain with kerosene. If the chain tends to rust faster, the intervals must be shortened.

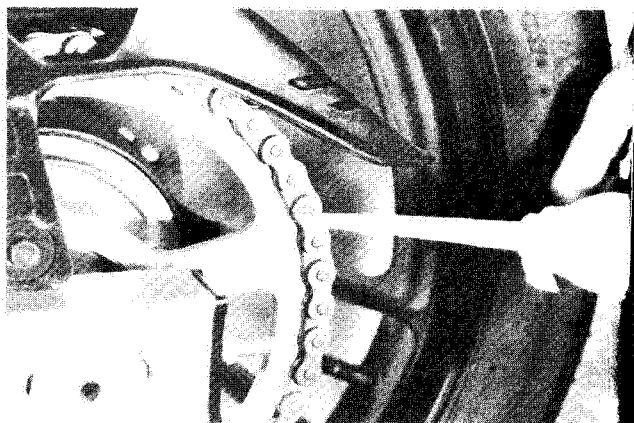

**CAUTION**

Do not use trichlene, gasoline or any similar fluids: These fluids have too great a dissolving power for this chain and what is more important, can damage the "O" rings confining the grease in the bush-to-pin clearance. Remember, high durability comes from the presence of grease in that clearance.

After washing and drying the chain, oil it with a heavy-weight motor oil.

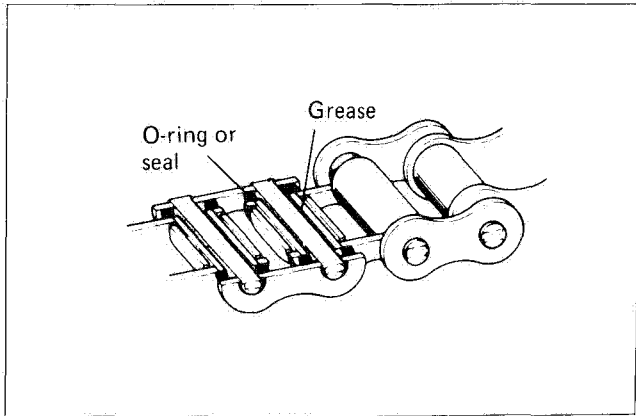

**CAUTION:**

Do not use any oil sold commercially as "drive chain oil". Such oil can damage the "O" rings.

**CAUTION:**

The standard drive chain in DAIDO DID525V or TAKASAGO RK525SM. SUZUKI recommends that the above-mentioned standard drive chain should be used for the replacement.

**BRAKES**

Inspect the brakes and brake hoses Initial  
1 000 km and Every 6 000 km  
Replace hoses Every 4 years  
Replace fluid Every 2 years

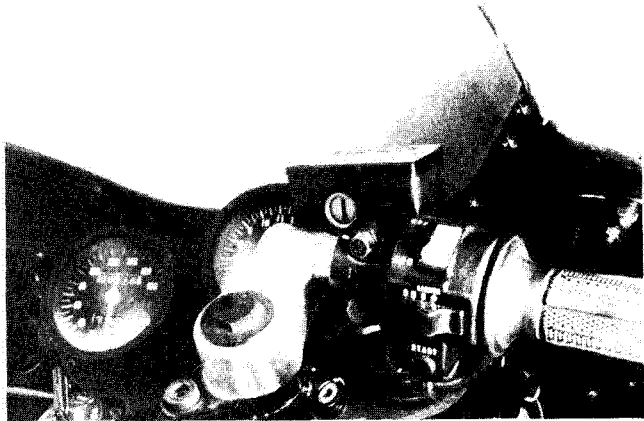

**BRAKE FLUID LEVEL**

- Keep the motorcycle upright and place the handlebars straight.
- Remove the right frame cover.
- Check the brake fluid level by observing the upper and lower limit lines on the brake fluid reservoirs, both front and rear.
- When the level is below the lower limit line, replenish with brake fluid that meets the following specification.

Specification and Classification	SAE J1703, DOT3 or DOT4
----------------------------------	-------------------------

99000-23021	SUZUKI Brake fluid
-------------	--------------------



**WARNING:**

The brake system of this motorcycle is filled with a glycol-based brake fluid. Do not use or mix different types of fluid such as silicone-based and petroleum-based fluid for refilling the system, otherwise serious damage will be caused. Do not use any brake fluid taken from old or used or unsealed containers. Never re-use brake fluid left over from the last servicing or stored for long periods.

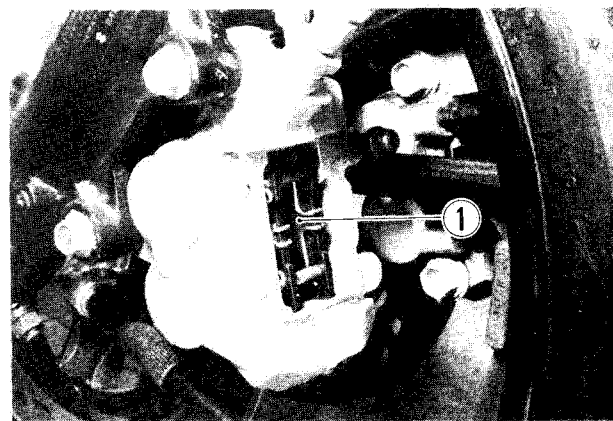
**WARNING:**

Brake fluid, if it leaks, will interfere with safe running and discolor painted surfaces. Check the brake hoses for cracks and hose joint for leakage before riding.

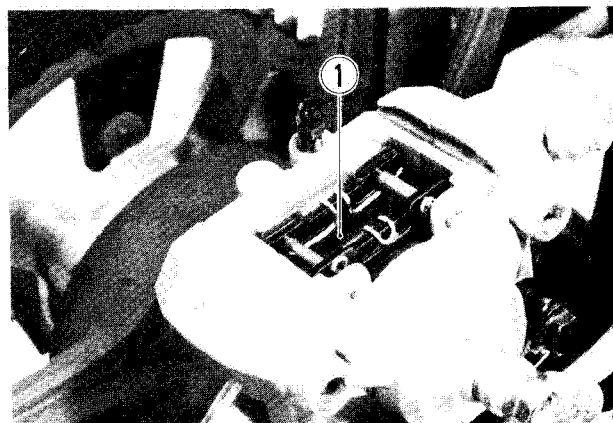
**BRAKE PADS**

The extent of brake pad wear can be checked by observing the limit line ① marked on the pad. When the wear exceeds the limit line, replace the pads with new ones. (see pages 7-9 and 7-27)

**BRAKE PEDAL HEIGHT**

- Loosen lock nut ②, and rotate the push rod ③ to locate brake pedal 50 mm ④ below the top face of the footrest.
- Retighten lock nut ②.

Brake pedal height ④	50 mm
----------------------	-------

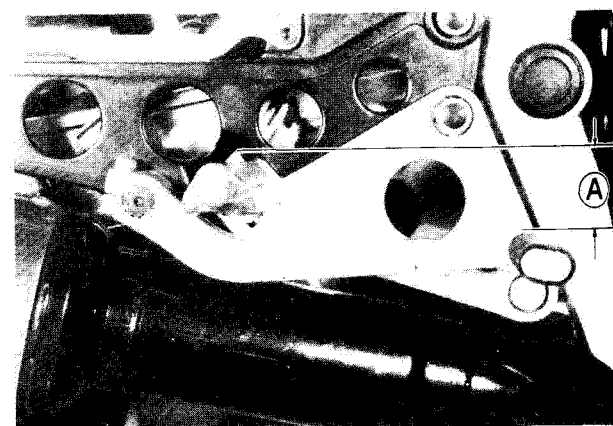
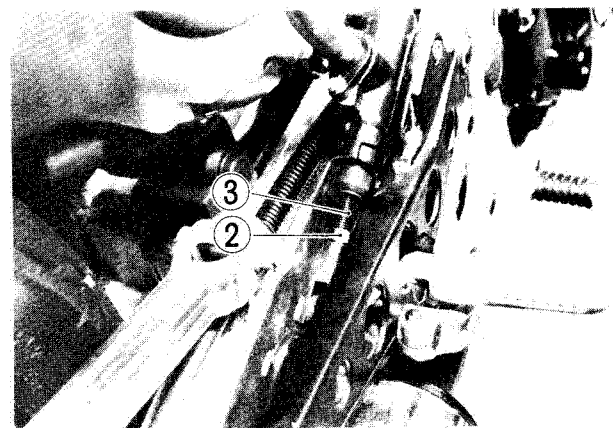

**BRAKE LIGHT SWITCHES**

Adjust both brake light switches, front and rear, so that brake light will come on just before a pressure is felt when the brake lever is squeezed, or the brake pedal is depressed.

**AIR BLEEDING THE BRAKE FLUID CIRCUIT**

Air trapped in the fluid circuit acts like a cushion to absorb a large proportion of the pressure developed by the master cylinder and thus interferes with the full braking performance of the caliper brake. The presence of air is indicated by "sponginess" of the brake lever and also by lack of braking force. Considering the danger to which such trapped air exposes the machine and rider, it is essential that, after remounting the brake and restoring the brake system to the normal condition, the brake fluid circuit be purged of air in the following manner.

- Fill up the master cylinder reservoir to the "HIGH" level line. Replace the reservoir cap to prevent entry of dirt.
- Attach a pipe to the left anti-dive bleeder valve, and insert the free end of the pipe into a receptacle.

Bleeder valve tightening torque	6 – 9 N·m (0.6 – 0.9 kg·m)
---------------------------------	-------------------------------

- Bleed the air in the following order.

① Left anti-dive device



② Left caliper



③ Right anti-dive device



④ Right caliper

**FRONT BRAKE AIR BLEEDING:**

It is common for air to become "trapped" in the extra hoses or valves of the anti-dive system. Repeating the sequence of brake bleeding will remove most of this air. If the lever feel is still spongy after several bleeding sequences it may be necessary to remove the anti-dive modulator from the anti-dive assembly. This will allow the modulator to be "tipped" upwards, enabling the trapped air to be purged from the system.

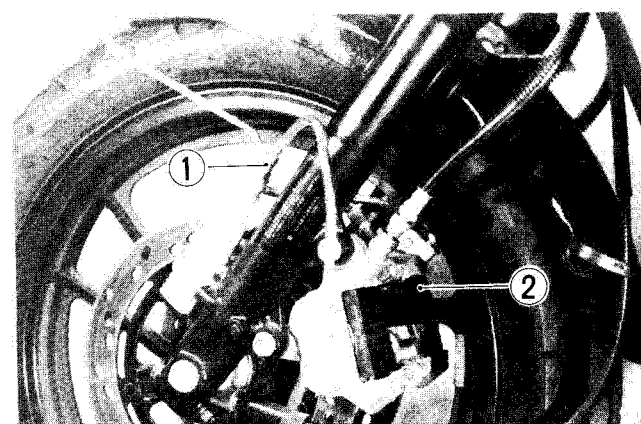
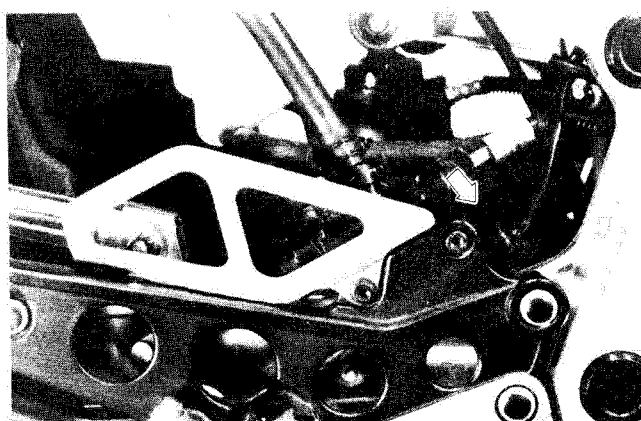
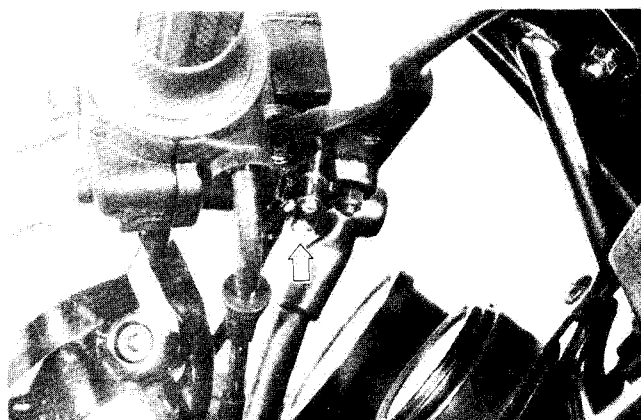

**CAUTION:**  
Be certain to retorque the modulator mounting screws after remounting onto the anti-dive assembly body. Thread lock "1342" should be used when reinstalling the bolts.

99000-32050	Thread lock "1342"
-------------	--------------------

- Squeeze and release the brake lever several times in rapid succession, and squeeze the lever fully without releasing it. Loosen the bleeder valve by turning it a quarter of a turn so that the brake fluid runs into the receptacle; this will remove the tension of the brake lever causing it to touch the handlebar grip. Then, close the valve, pump and squeeze the lever, and open the valve. Repeat this process until the fluid flowing into the receptacle no longer contains air bubbles.

**NOTE:**

Replenish the brake fluid reservoir as necessary while bleeding the brake system. Make sure that there is always some fluid visible in the reservoir.

- Close the bleeder valve, and disconnect the pipe. Fill the reservoir to the "HIGH" level line.

**CAUTION:**

Handle brake fluid with care: the fluid reacts chemically with paint, plastics, rubber materials, etc.

- The only difference between bleeding the front and rear brakes that the rear master cylinder is actuated by a pedal.

**TIRES**

Inspect Initial 1 000 km and  
Every 6 000 km

**TIRE TREAD CONDITION**

Operating the motorcycle with excessively worn tires will decrease riding stability and consequently invite a dangerous situation. It is highly recommended to replace a tire when the remaining depth of tire tread reaches the following specification.

FRONT	REAR
1.6 mm	2.0 mm

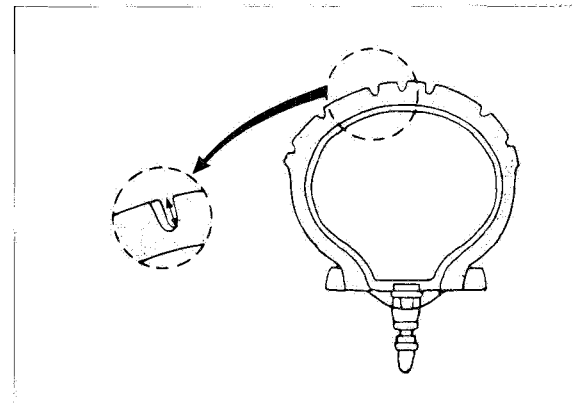
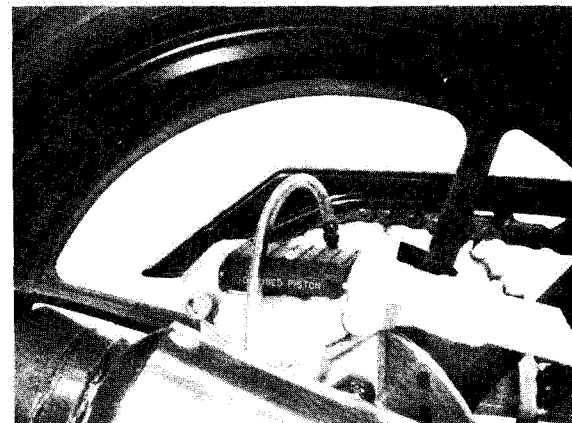
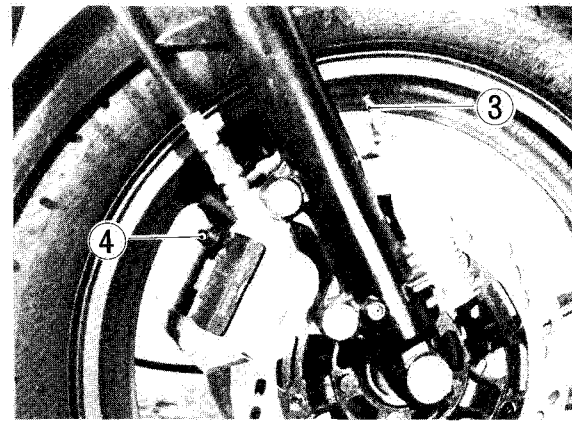

## TIRE PRESSURE

If the tire pressure is too high or too low, steering will be adversely affected and tire wear increased. Therefore, maintain the correct tire pressure for good roadability or shorter tire life will result. Cold inflation tire pressure is as follows.

	FRONT		REAR	
	kPa	kg/cm <sup>2</sup>	kPa	kg/cm <sup>2</sup>
Solo	200	2.00	200	2.00
Dual	225	2.25	250	2.50

### CAUTION:

The standard tire fitted on this motorcycle is 100/90-16 54H for front and 110/90-18 61H for rear. The use of tires other than the those specified may cause instability. It is highly recommended to use a SUZUKI Genuine Tire.

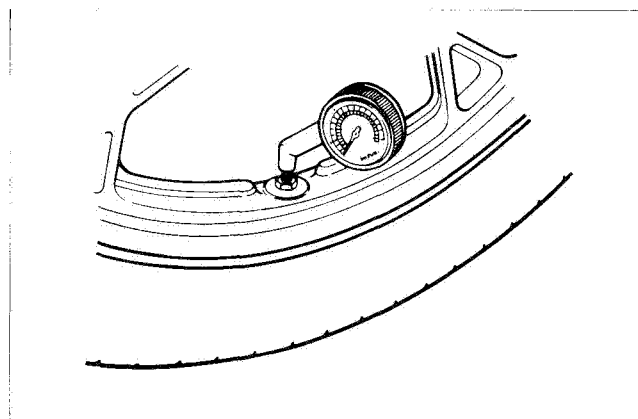

## STEERING

Inspect Initial 1 000 km and  
Every 6 000 km

Check that there is no play in the front fork assembly by supporting the machine so that the front wheel is off the ground, with the wheel straight ahead, grasp the lower fork tubes near the axle and pull forward. If play is found, perform steering bearing adjustment as described in page 7-22 of this manual.

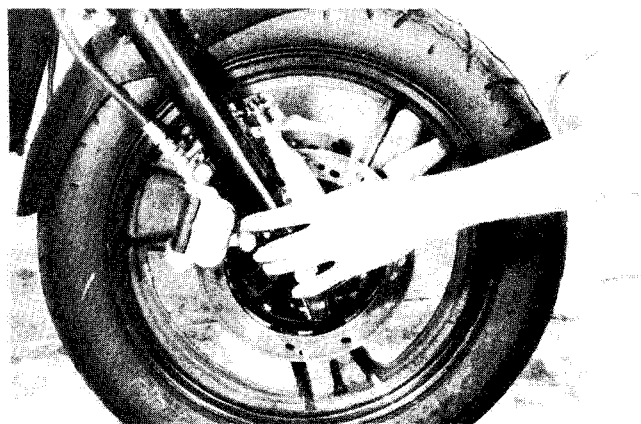

## FRONT FORK

Change oil Initial 1 000 km and  
Every 12 000 km

Inspect the front fork for oil leakage, scoring or scratches on the outer surface of the inner tube every 12 000 km and replace the defective parts, if necessary.

When changing fork oil, refer to page 7-16.

## CHASSIS BOLTS AND NUTS

Tighten Initial 1 000 km and Every 6 000 km

The bolts and nuts listed hereunder are important safety parts. They must be retightened, as necessary to the specified torque with a torque wrench. Refer to the figure for position of the following bolts and nuts.

	ITEM	N·m	kg-m
1	Front axle nut ✓	36 – 52	3.6 – 5.2
2	Front axle pinch bolt	15 – 25	1.5 – 2.5
3	Caliper mounting bolt ✓	15 – 25	1.5 – 2.5
4	Caliper housing bolt ✓	30 – 36	3.0 – 3.6
5	Disc plate bolt	15 – 25	1.5 – 2.5
6	Handlebar set bolt	50 – 60	5.0 – 6.0
7	Front fork cap bolt	15 – 30	1.5 – 3.0
8	Front fork upper clamp bolt	15 – 25	1.5 – 2.5
9	Steering stem head bolt	20 – 30	2.0 – 3.0
10	Steering stem clamp bolt	15 – 25	1.5 – 2.5
11	Front brake master cylinder clamp bolt	5 – 8	0.5 – 0.8
12	Front fork lower clamp bolt	15 – 25	1.5 – 2.5
13	Brake hose union bolt ✓	20 – 25	2.0 – 2.5
14	Rear cushion lever nut (Center)	40 – 60	4.0 – 6.0
15	Rear torque link nut (Front)	10 – 15	1.0 – 1.5
16	Rear torque link nut (Rear) ✓	20 – 30	2.0 – 3.0
17	Rear shock absorber bolt (Upper & Lower)	40 – 60	4.0 – 6.0
18	Rear master cylinder mounting bolt ✓	6 – 10	0.6 – 1.0
19	Rear brake reservoir mounting bolt ✓	5 – 8	0.5 – 0.8
20	Rear cushion rod nut	18 – 28	1.8 – 2.8
21	Rear cushion lever nut (Front)	40 – 60	4.0 – 6.0
22	Brake pedal arm bolt	6 – 10	0.6 – 1.0
23	Swingarm pivot nut	50 – 80	5.0 – 8.0
24	Rear axle nut ✓	50 – 80	5.0 – 8.0
25	Rear brake caliper housing bolt ✓	30 – 36	3.0 – 3.6
26	Rear brake caliper mounting bolt ✓	15 – 25	1.5 – 2.5



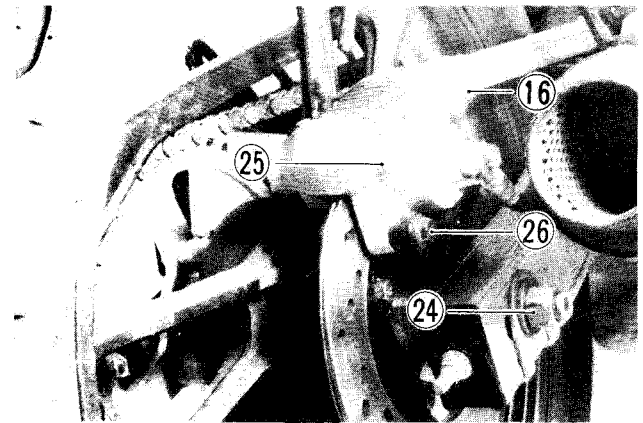
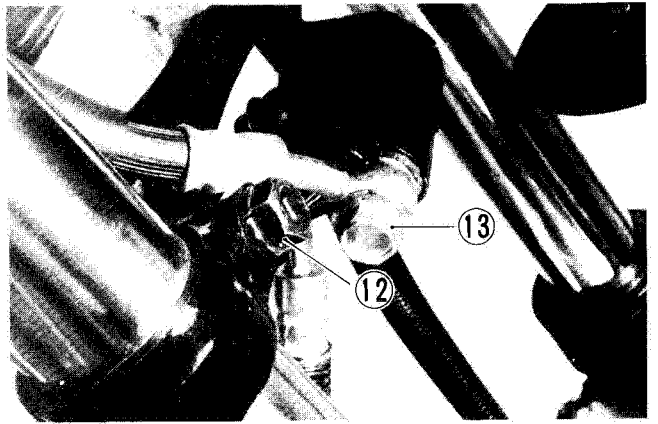
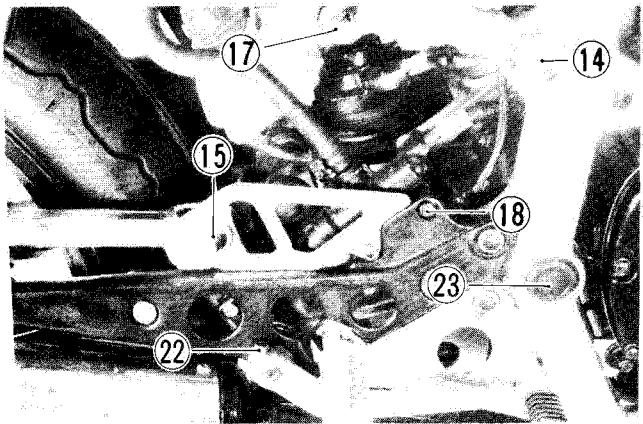
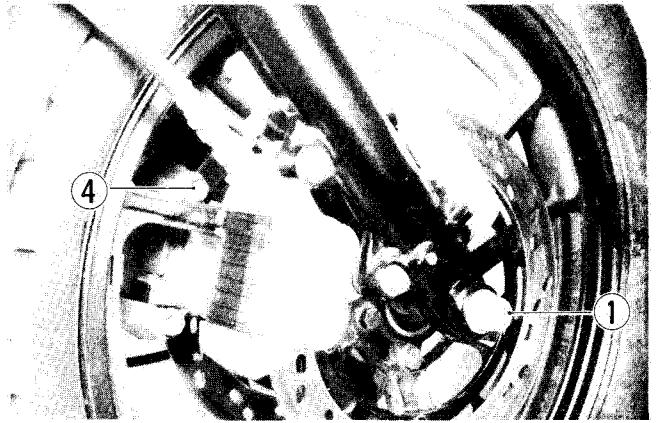
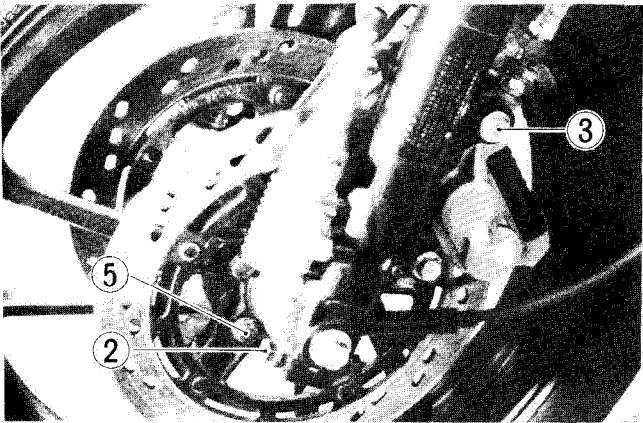
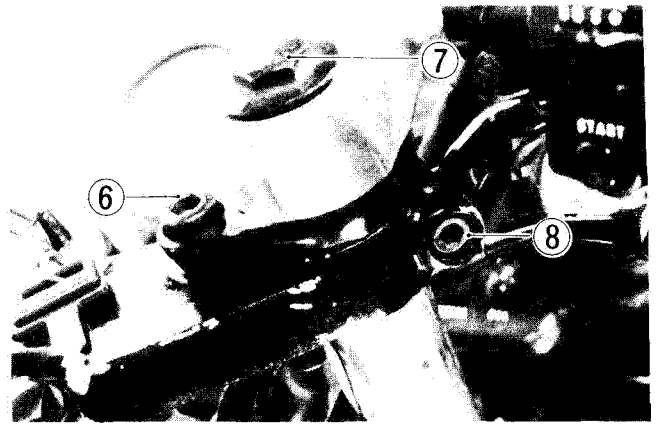
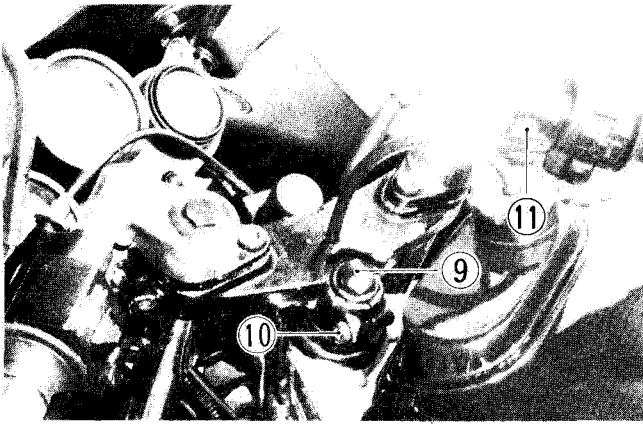

# ENGINE

## CONTENTS

<b>COMPRESSION CHECK</b> .....	<b>3- 1</b>
<b>ENGINE COMPONENTS REMOVABLE WITH ENGINE IN PLACE</b> .....	<b>3- 2</b>
<b>ENGINE REMOVAL AND REINSTALLATION</b> .....	<b>3- 3</b>
<b>ENGINE DISASSEMBLY</b> .....	<b>3-11</b>
<b>ENGINE COMPONENTS INSPECTION AND SERVICING</b> .....	<b>3-21</b>
<b>CYLINDER HEAD DISASSEMBLY</b> .....	<b>3-21</b>
<b>VALVE</b> .....	<b>3-22</b>
<b>CAMSHAFT</b> .....	<b>3-28</b>
<b>CAM CHAIN TENSIONER</b> .....	<b>3-31</b>
<b>CYLINDER</b> .....	<b>3-32</b>
<b>PISTON</b> .....	<b>3-33</b>
<b>PISTON RING</b> .....	<b>3-33</b>
<b>CONNECTING ROD</b> .....	<b>3-35</b>
<b>CRANKSHAFT</b> .....	<b>3-35</b>
<b>CLUTCH</b> .....	<b>3-44</b>
<b>STARTER CLUTCH REMOVAL</b> .....	<b>3-45</b>
<b>OIL PUMP</b> .....	<b>3-46</b>
<b>TRANSMISSION GEARS AND RELATED PARTS</b> .....	<b>3-47</b>
<b>ENGINE REASSEMBLY</b> .....	<b>3-51</b>
<b>CRANKCASE</b> .....	<b>3-52</b>
<b>STARTER CLUTCH</b> .....	<b>3-56</b>
<b>CLUTCH</b> .....	<b>3-59</b>
<b>SIGNAL GENERATOR</b> .....	<b>3-60</b>
<b>PISTON RING</b> .....	<b>3-61</b>
<b>CYLINDER</b> .....	<b>3-62</b>
<b>CAMSHAFT</b> .....	<b>3-64</b>

## COMPRESSION CHECK

The compression of a cylinder is good indicator of its internal condition. The decision to overhaul the cylinders is often based on the results of a compression test. Periodic maintenance records kept at your dealership should include compression readings for each maintenance service.

### COMPRESSION

Standard	Limit	Difference
1 100 – 1 500 kPa (11 – 15 kg/cm <sup>2</sup> )	900 kPa (9 kg/cm <sup>2</sup> )	200 kPa (2 kg/cm <sup>2</sup> )

Low compression pressure can indicate any of the following conditions:

- \* Excessively worn cylinder wall
- \* Worn-down piston or piston rings
- \* Piston rings stuck in the grooves
- \* Poor seating of valves
- \* Ruptured or otherwise defective cylinder head gasket

Overhaul the engine in the following cases:

- \* Compression pressure in one of the cylinders is less than 900 kPa (9 kg/cm<sup>2</sup>).
- \* Difference in compression pressure between any two cylinders is more than 200 kPa (2 kg/cm<sup>2</sup>).
- \* All compression pressure are below 1 100 kPa (11 kg/cm<sup>2</sup>) (standard) even when they measure more than 900 kPa (9 kg/cm<sup>2</sup>).

### COMPRESSION TEST PROCEDURE

#### NOTE:

- \* Before testing the compression of the engine, make sure that the cylinder head nuts and bolt are tightened to specific torque values and valves are properly adjusted.
- \* Warm up the engine before testing.

- Remove the fuel tank.
- Remove the all spark plugs.
- Fit the compression gauge ① in one of the holes, while taking care that the connector is tight.
- Twist the throttle grip full open.
- Crank the engine a few seconds with the starter and record the maximum gauge reading as compression of the cylinder.
- Repeat this procedure with the other cylinders.

09915-64510	Compression gauge
09915-63310	Adapter

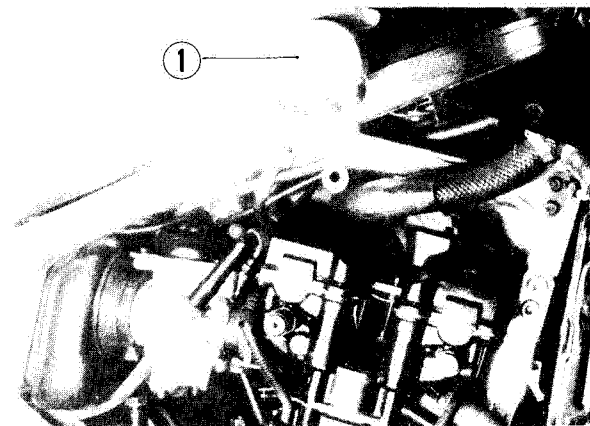

## ENGINE COMPONENTS REMOVABLE WITH ENGINE IN PLACE

The parts listed below can be removed and reinstalled without removing the engine from the frame. Refer to the page listed in this section for removal and reinstallation instructions.

ENGINE LEFT SIDE	See page	ENGINE CENTER	See page	ENGINE RIGHT SIDE	See page
Gearshift lever .....	3- 6	Radiator .....	3- 4	Signal generator .....	3-13
Engine sprocket cover .....	3- 6	Exhaust pipe and muffler .....	3- 4	Clutch cover .....	3-13
Engine sprocket and driver chain .....	3- 6	Oil filter .....	2-10	Clutch pressure, drive and driven plates .....	3-13
Gear position indicator switch body .....	3-17	Oil pan .....	3-17	Oil pump driven gear .....	3-14
Generator cover .....	3-15	Oil level switch .....	3-17	Oil pump assembly .....	3-14
Generator rotor .....	3-16	Sump filter .....	3-18	Primary driven gear .....	3-14
Generator stator .....	3-46	Cylinder head breather cover .....	3- 7	Gear shifting shaft .....	3-15
Starter clutch .....	3-46	Carburetor .....	3- 5		
Starter clutch idle gear .....	3-16	Throttle cable and starter cable .....	3- 5		
Water pump .....	3-16	Cam chain tensioner .....	3-11		
		Cylinder head cover .....	3-11		
		Camshaft .....	3-11		
		Cylinder head .....	3-12		
		Cylinder .....	3-12		
		Piston .....	3-13		
		Starter motor .....	3-16		

## ENGINE REMOVAL AND REINSTALLATION

### ENGINE REMOVAL

Before taking out the engine from the frame, wash the engine with a steam cleaner, and drain engine oil and coolant etc. The procedure of engine removal is sequentially explained in the following steps, and engine installation is effected by reversing the removal procedure.

- Place an oil pan under the engine and remove the oil drain plug ① and filler plug to drain out engine oil.
- Remove the radiator cap ② and drain plug ③, and drain coolant completely.
- Remove the seat and remove the right and left frame covers.
- Disconnect the battery  $\ominus$  and  $\oplus$  lead wires from the battery terminals, and remove the battery from the battery holder.
- Remove the two bolts at rear of the fuel tank.
- Turn the fuel cock lever to OFF position and shift the hose clip sideways and disconnect the fuel cock/carburetor hose.
- Remove the fuel cock from the frame, and remove the fuel tank.

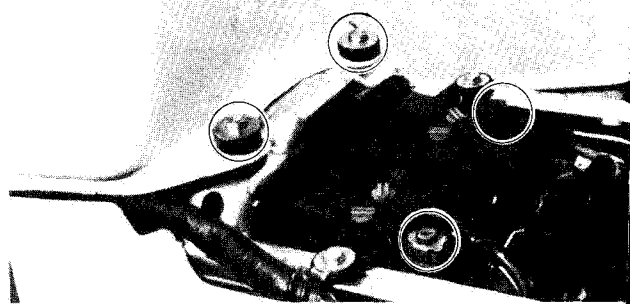
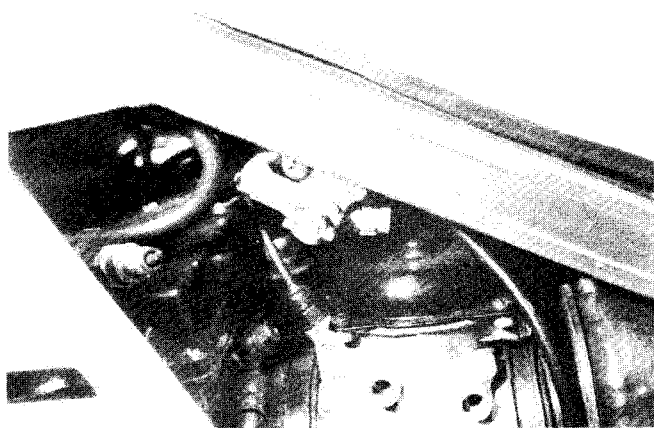
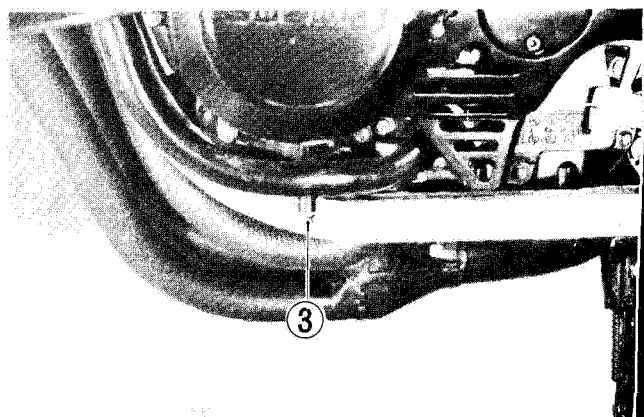
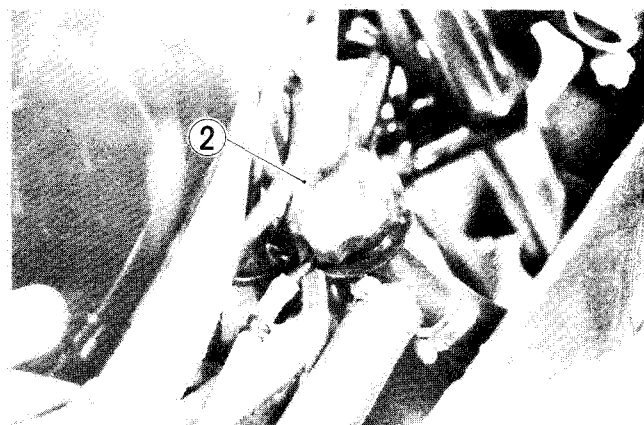
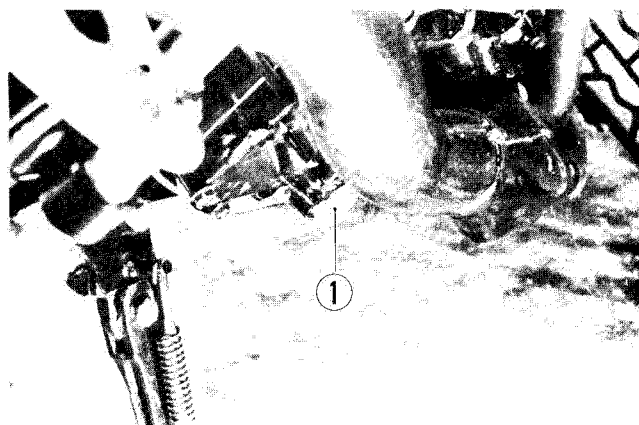

- Remove the fairing from the chassis.
- Loosen the clamps and disconnect the following hoses.
  - ① Radiator to water pump hose
  - ② Radiator to reservoir tank hose
  - ③ Cylinder head to radiator hose
- Disconnect the electric fan lead wire.
- Remove the radiator.
- Remove the muffler by unscrewing exhaust pipe clamp bolts and muffler mounting bolt.

09900-00401

L-type hexagon wrench set

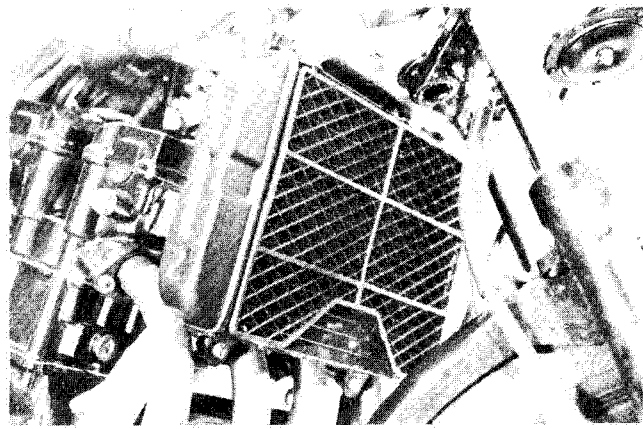
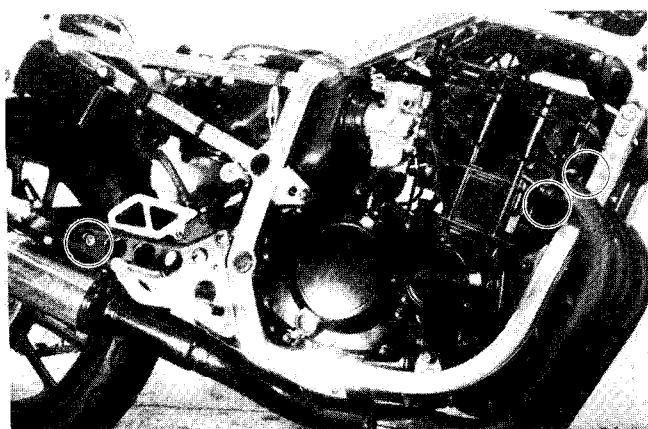
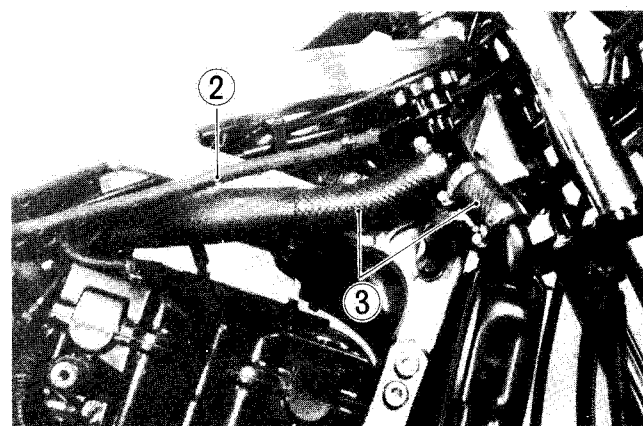
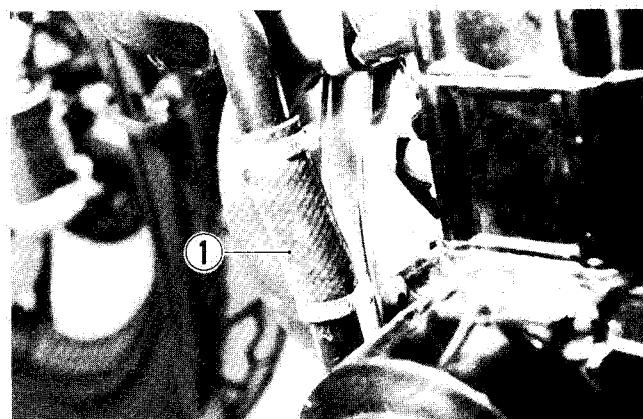
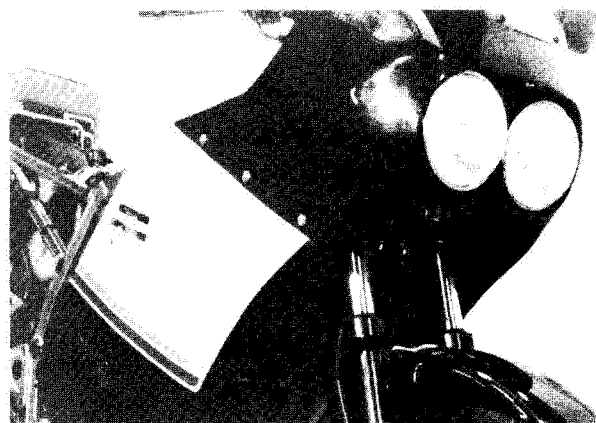

- Disconnect the various lead wires.
  - \* Starter relay ⊖ lead wire
  - \* Signal generator lead wire
  - \* Engine ground lead wire (Battery ⊖ lead).
  - \* Oil level gauge lead wire (BI/W)
  - \* Neutral indicator lead wire (BI)
  - \* Generator lead wire (Y)
  - \* Water temperature gauge lead wire (B/G)
  - \* Electric fan switch lead wire

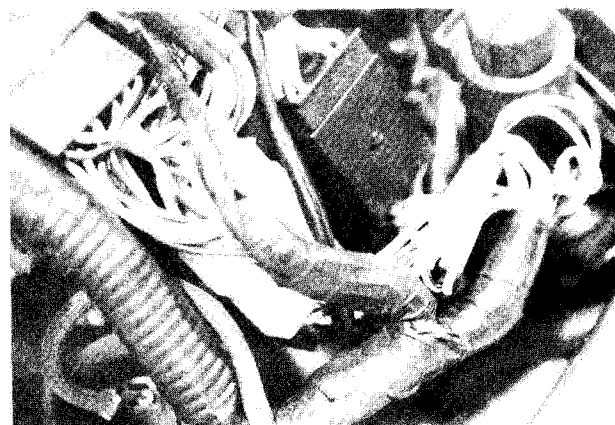
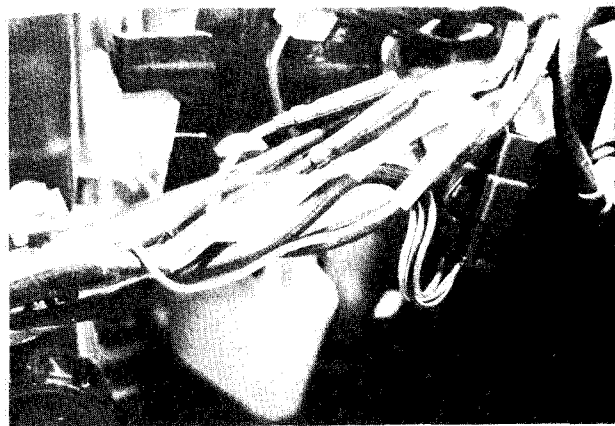

- Loosen the air cleaner case clamp screw and carburetor clamp screws.
- Disconnect the breather pipe from the cylinder head cover cap.

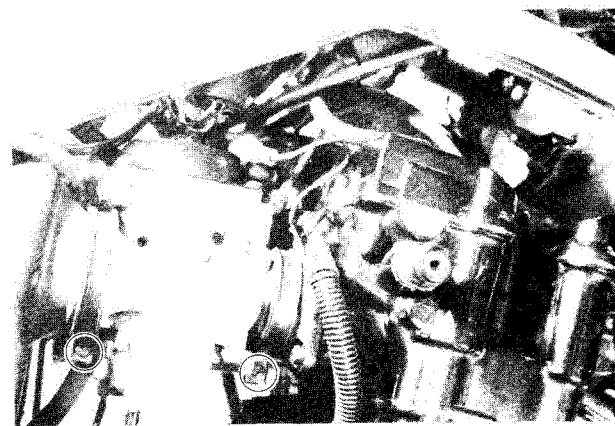

- Slide the air cleaner case backward.
- Remove the choke cables from the carburetors.
- Remove the carburetors.

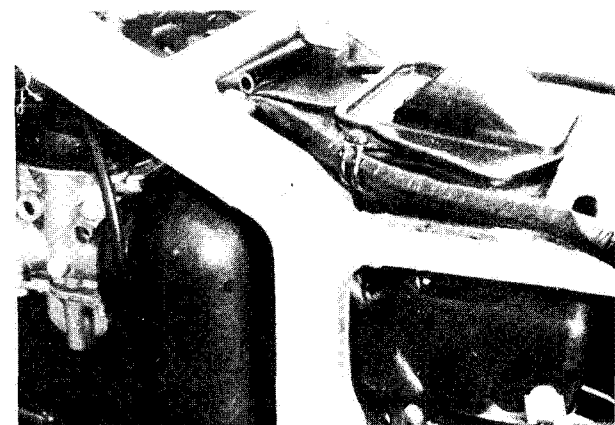

- Disconnect the throttle cable from the throttle lever.

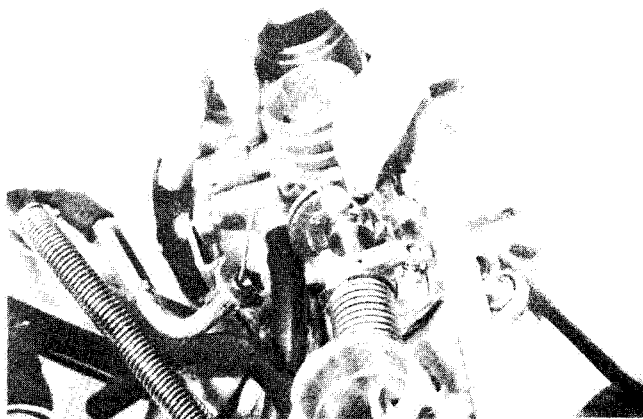

- Remove the gearshift level.
- Remove the engine sprocket cover.

09900-00302-015

8-mm box wrench

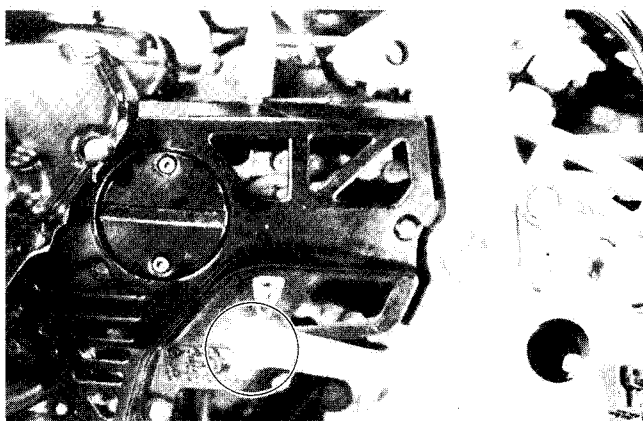

- Remove the water pump inlet and outlet pipes from the water pump and cylinder.

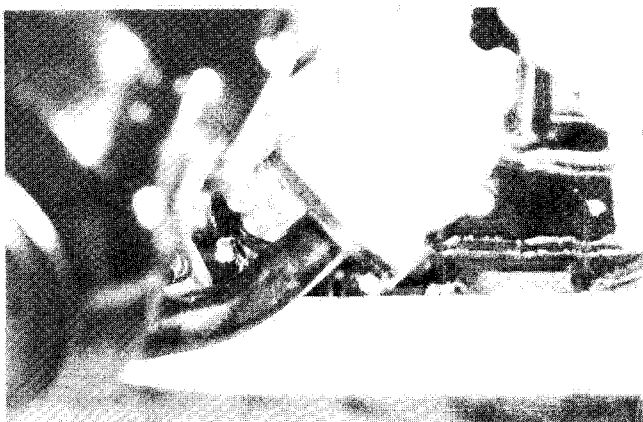

- Remove the engine sprocket by using snap ring pliers from the driveshaft.

09900-06107

Snap ring pliers

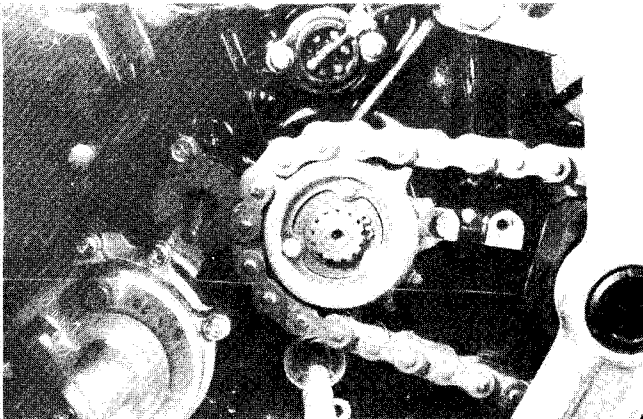
**NOTE:**

Loosen the rear axle nut and chain adjusters. Push the rear wheel forward and disengage the drive chain from engine sprocket. Which facilitates the engine sprocket removal.



- Disconnect the spark plug caps from the spark plugs and remove the electric fan cover.

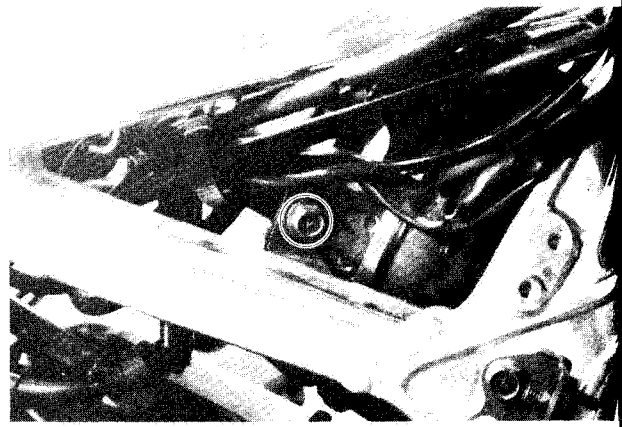

- Remove the cooling duct, engine mounting bolts, brackets and right down tube mounting bolts.
- Gradually lift up the engine and remove the engine assembly from the right side.

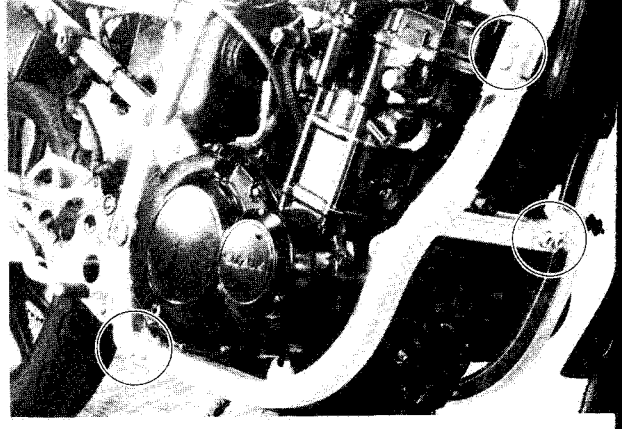
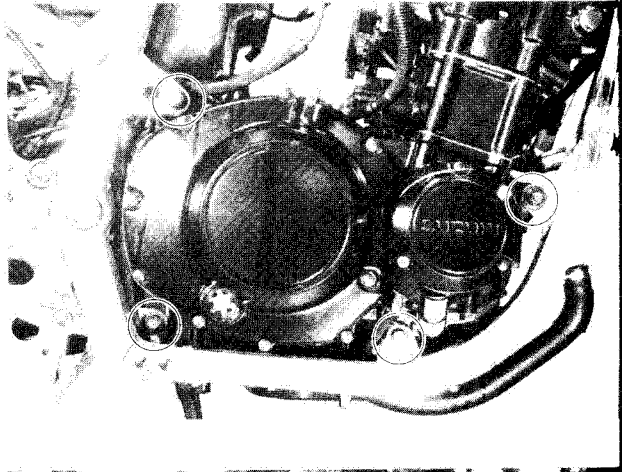

## ENGINE REINSTALLATION

Reinstall the engine in the reverse order of engine removal.

- After inserting the engine mounting bolts, tighten the engine mounting bracket bolts and engine mounting bolts.

Insert the all three long bolts from left side. Install the brackets, spacer, bolts and nuts properly as shown in the following illustration.

### NOTE:

The engine mounting nuts are self-lock nut. Once the nut has been removed, it is no longer of any use. Be sure to use new nuts and tighten them to the specified torque.

## TIGHTENING TORQUE

ITEM	N·m	kg-m
Ⓐ	60 – 72	6.0 – 7.2

## LENGTH

①	270 mm
②	165 mm
③	170 mm

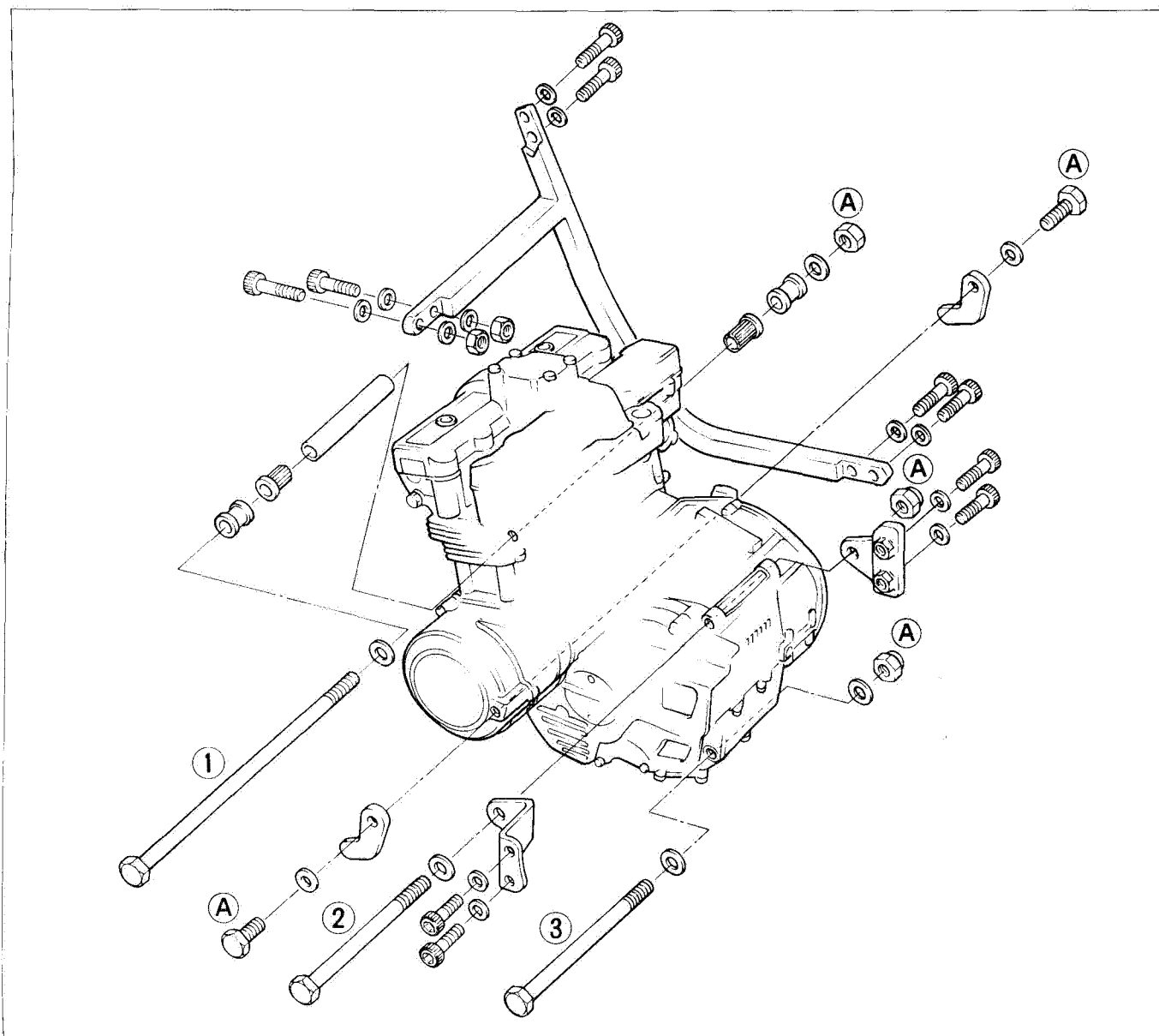

- Install the water hose and pipe to the water pump and cylinder.

Water pipe flange tightening torque	4 – 7 N·m (0.4 – 0.7 kg-m)
-------------------------------------	-------------------------------

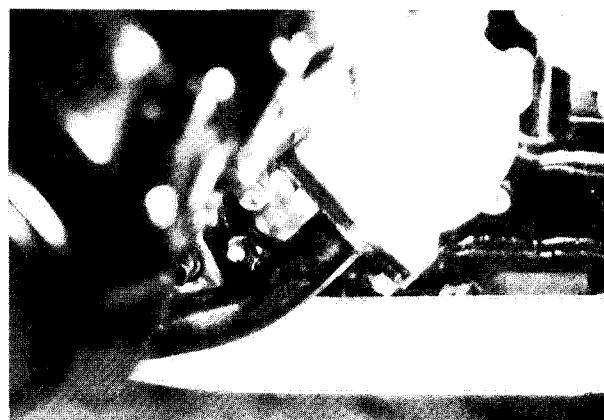

- Install the exhaust pipes and muffler properly. When securing the exhaust pipe clamp bolts, make sure that clamps are positioned properly.

#### Tightening torque

	N·m	kg-m
Exhaust pipe clamp bolt	9 – 12	0.9 – 1.2

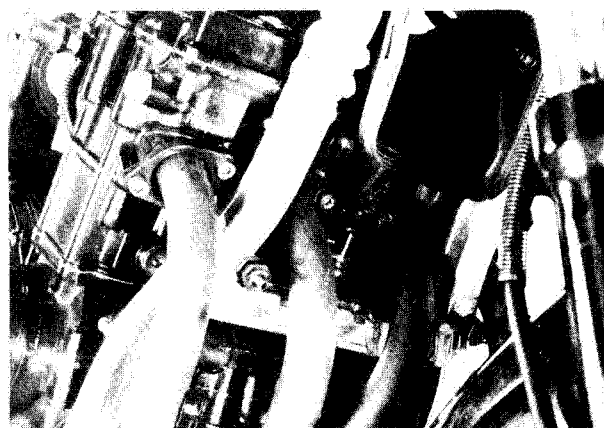

- Mount the radiator to the chassis and tighten the water hose clamps properly.

Radiator mounting nut tightening torque	7 – 9 N·m (0.7 – 0.9 kg-m)
---	-------------------------------

- Replace the plug caps on the spark plugs so that their code markings correspond to the cylinder numbers in the order of 1, 2, 3 and 4 from the left.

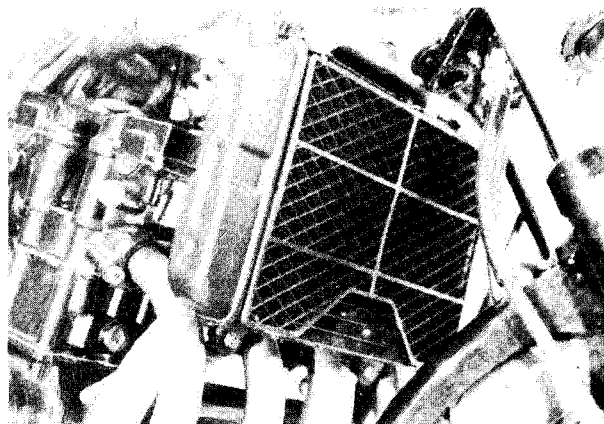

- Firmly secure the carburetors with the clamps. If the carburetors are not firmly secured, gas leakage, incorrect air-fuel ratio and unsatisfactory engine operation may result.
- Pour 3.3 L (when overhauling engine) of engine oil SAE 10W/40 under API classification SE or SF into the engine. Several minutes after starting and stopping the engine, check that the oil level remains between the marks of oil inspection window.
- After remounting the engine, route wiring harness and cables properly by referring to the sections, wire routing and cable routing, and adjust the following items to the specification.

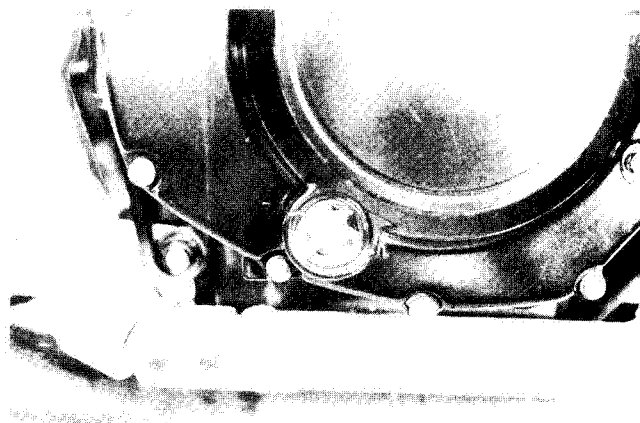

	Page
* Rear brake pedal . . . . .	2-15
* Brake light switch . . . . .	2-16
* Clutch cable . . . . .	2-11
* Throttle cable . . . . .	2- 9
* Choke cable . . . . .	2- 9
* Drive chain play . . . . .	2-13
* Balancing carburetor . . . . .	4-14
* Idling adjustment . . . . .	2- 9
* Filling coolant . . . . .	2-11

## ENGINE DISASSEMBLY

- Remove the cylinder head cover and its gasket.

09900-00401

L-type hexagon wrench set

**NOTE:**

Do not miss the O-rings located with screws.

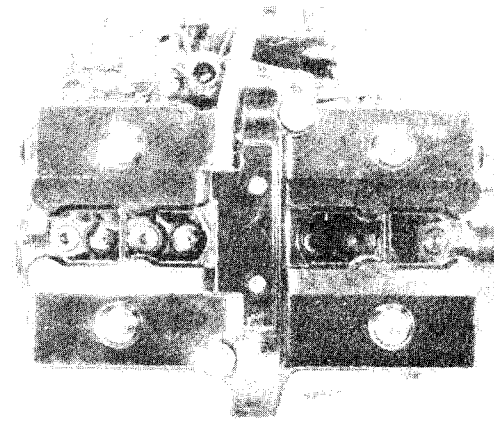

- Remove the cam chain tensioner by removing the two mounting bolts.

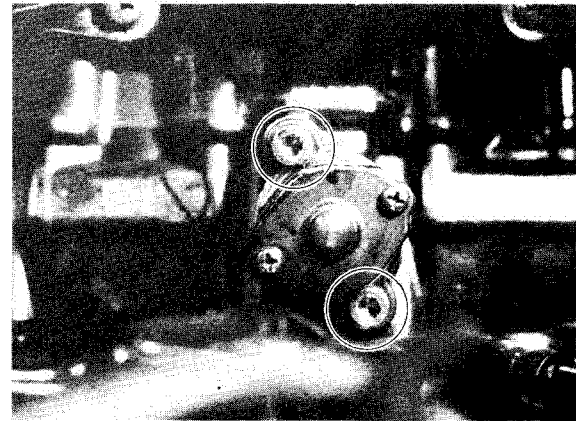

- Remove the four camshaft holders.
- Remove the two camshafts, intake and exhaust.

**NOTE:**

Be sure to loosen camshaft holder bolts evenly by shifting the wrench diagonally.

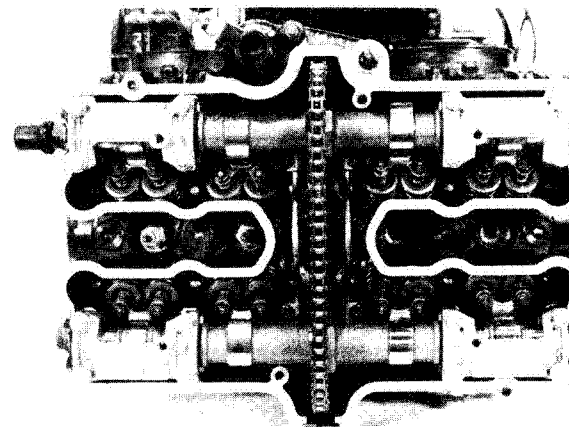

- Pull out the cam chain guide.

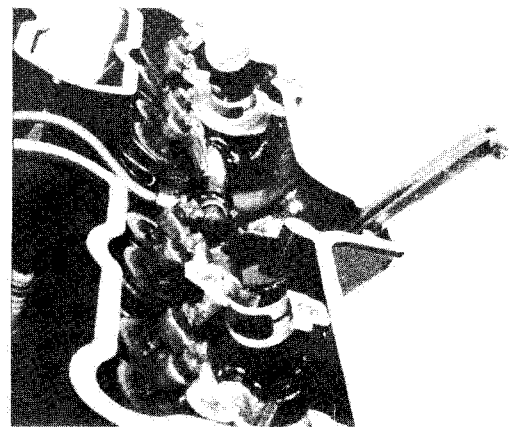

- Remove the two oil hoses by removing the union bolts.

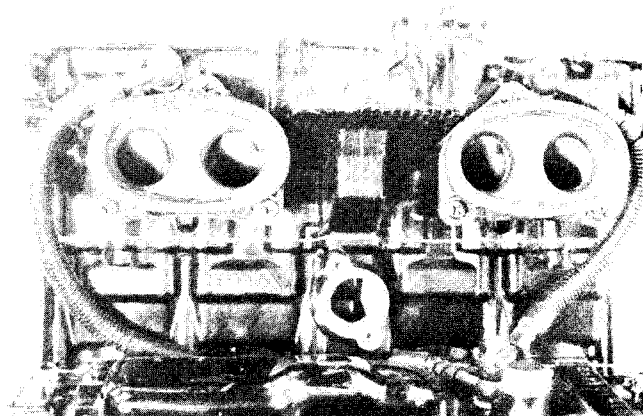

- The cylinder head becomes free for removal when its one 6-mm bolt (A) and twelve 8-mm nuts are removed.

09911-74520	Long socket 12 mm
09914-24510	T handle

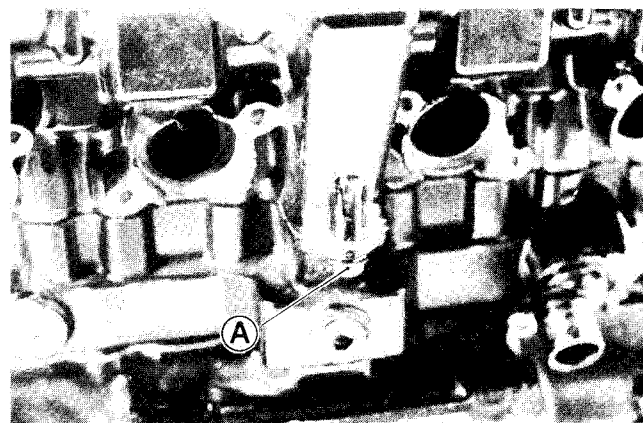

- Remove the two oil pipes by removing four allen bolts.

09900-00401	L-type hexagon wrench set
-------------	---------------------------

**NOTE:**

Be sure to use the special tool ("T" wrench) designed to enter the pockets formed in the head and reach the nuts down below to loosen the 8-mm nuts, and to shift the tool sequentially in the nuts descending order of numbers in order to reduce the pressure equally and evenly.

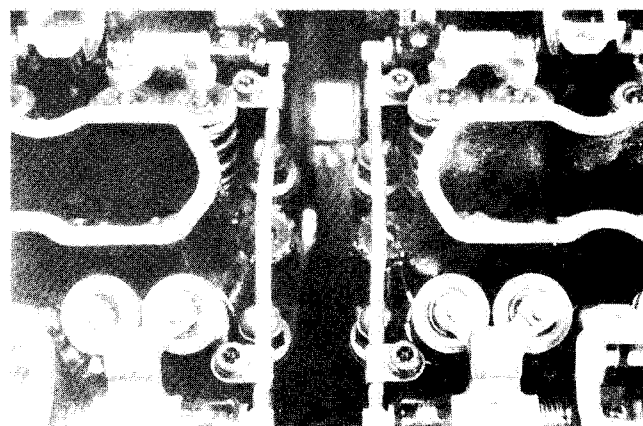

- Firmly grip the cylinder block at both ends, and lift it straight up. If the block does not come off, lightly tap on the block with a plastic mallet to shake the gasketed joint loose.
- Place a cloth beneath the piston so as not to drop the parts in the crankcase, and remove the circlip with pliers.

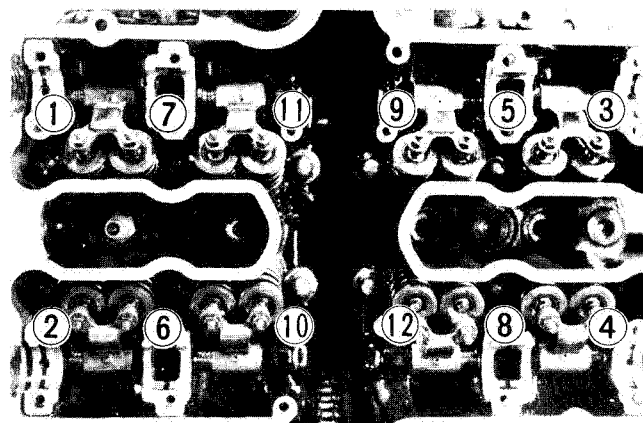

- Scribe the cylinder No. on the head of the piston, and draw out the piston pin with the special tool ①. Place the drawn-out piston pin in the same place as that given the cylinder No. on the head of the piston.

09910-34510

Piston pin puller

**NOTE:**

Place each piston pin in the same piston that it was removed from.

- Remove the signal generator cover.

09900-06711

7 mm T-type box wrench

- Apply wrench to crank turning nut to remove the signal generator rotor mounting bolt.

09900-00401

L-type hexagon wrench set

- Remove the signal generator stator assembly by removing the two mounting screws ②.

- Remove the clutch cover and its gasket.

09900-00302-015

8 mm T-type box wrench

**NOTE:**

Two gaskets are used for oil-tight at the bolts ①.

- By holding the crankshaft with conrod stopper, remove clutch spring mounting bolts in a criss-cross manner.
- Remove the clutch springs, pressure plate and clutch push piece.

09910-20116

Conrod stopper

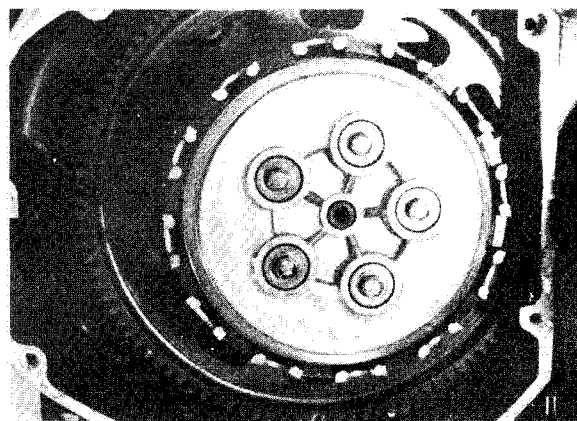
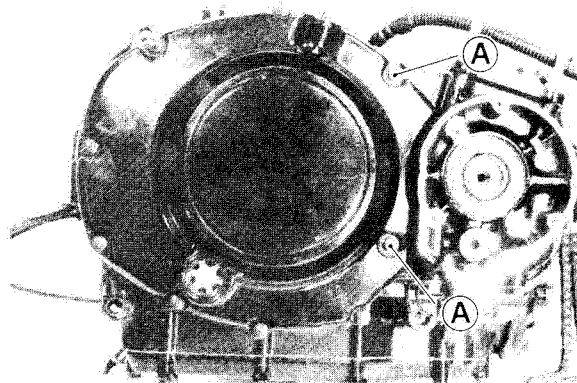
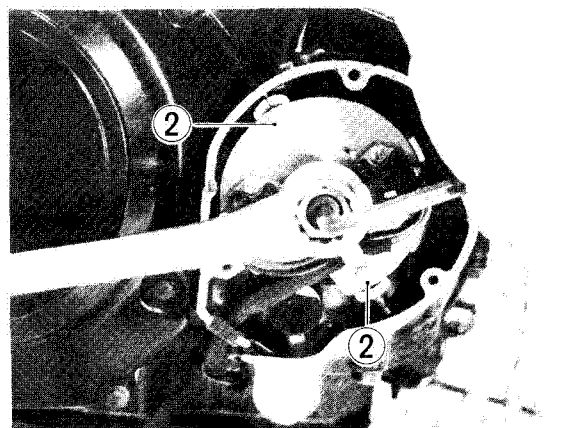
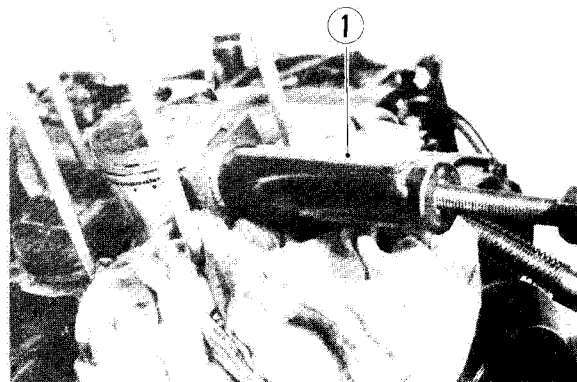

- After removal of several clutch driven and drive plates, flatten clutch sleeve hub nut lock washer by using chisel.
- Firmly secure the clutch sleeve hub to remove the mounting nut with clutch sleeve hub holder.

09920-53710

Clutch sleeve hub holder

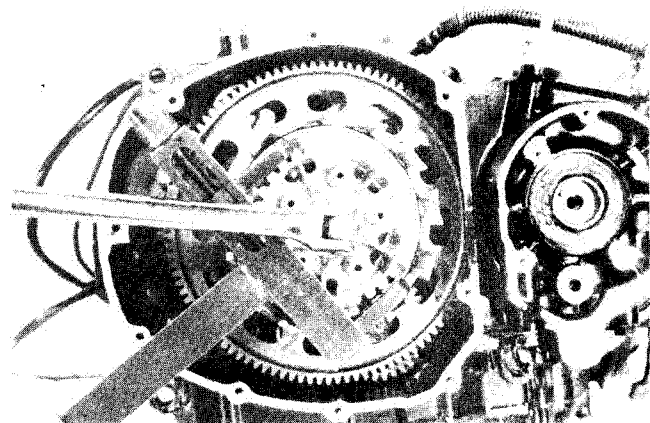

- Remove the washer and clutch hub.
- Run two 4-mm screws into the primary driven gear spacer to ease out the spacer by pulling. With the spacer removed, the primary driven gear (integral with the clutch housing) is free to disengage from the primary drive gear.

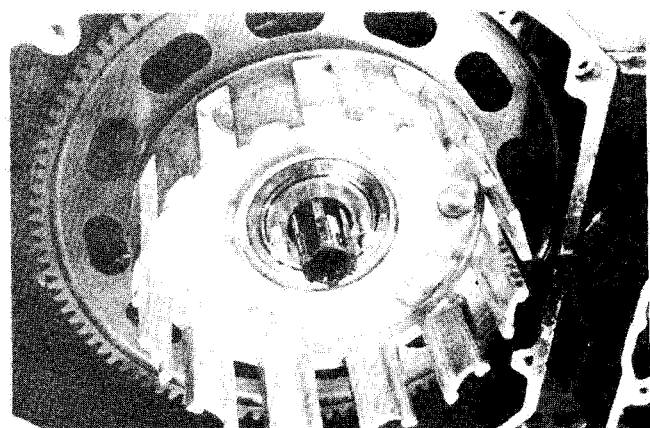

- Remove the thrust washers from the counter-shaft.

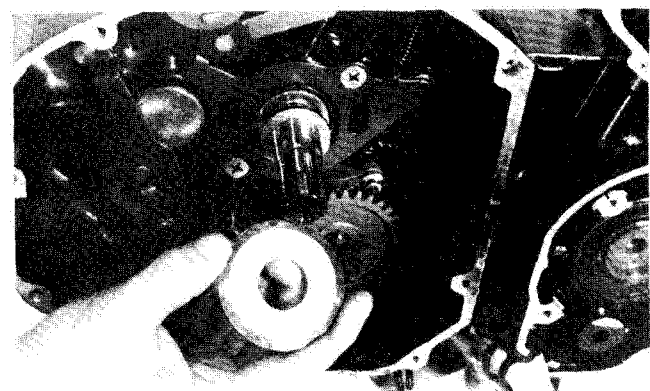

- Using a circlip remover, remove the oil pump driven gear, drive pin and washer. Then remove the oil pump with O-ring by removing the three oil pump securing bolts.

09900-06107

Snapping pliers

**NOTE:**

If it is difficult to draw out the oil pump assembly, remove the water pump and tap the oil pump shaft from the other side.

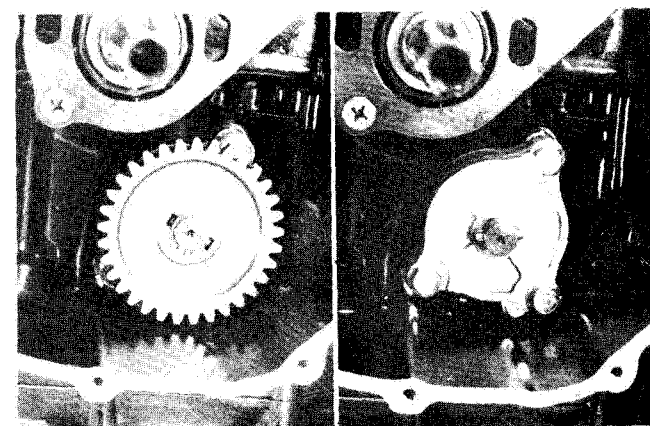



- Remove the cam stopper and its spring.

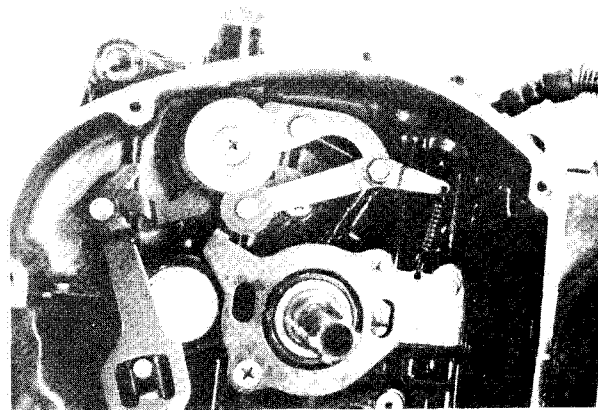

- Remove the gearshift shaft stopper clip and washer, and pull out the gearshift shaft from the other side.

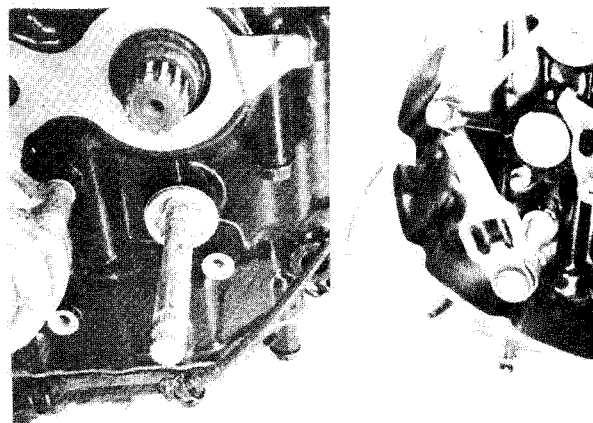

- Remove the countershaft bearing retainer.

09900-09003	Impact driver set
-------------	-------------------

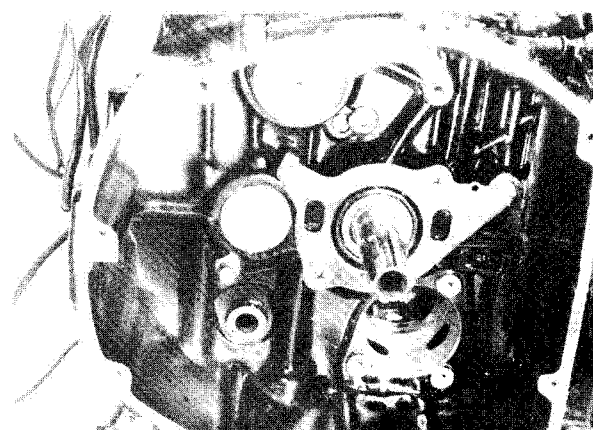

- Remove the generator cover and its gasket.

09900-00302-015	8 mm T-type box wrench
-----------------	------------------------

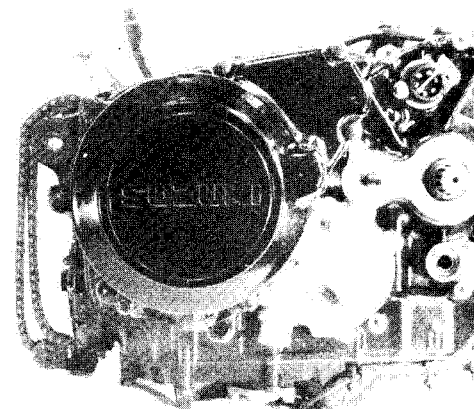

- Remove the starter motor.

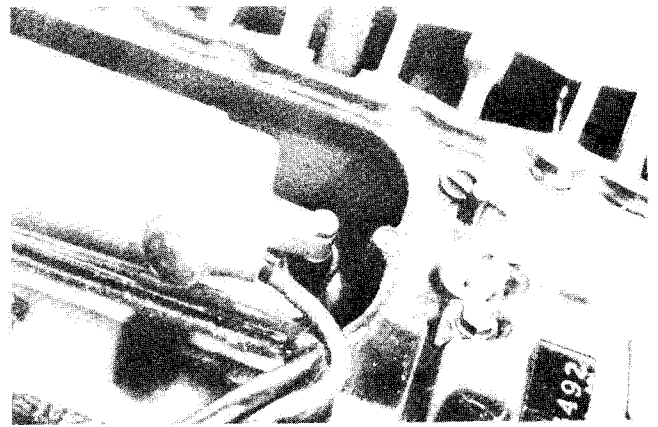

- Remove the starter idle gear shaft and idle gear.

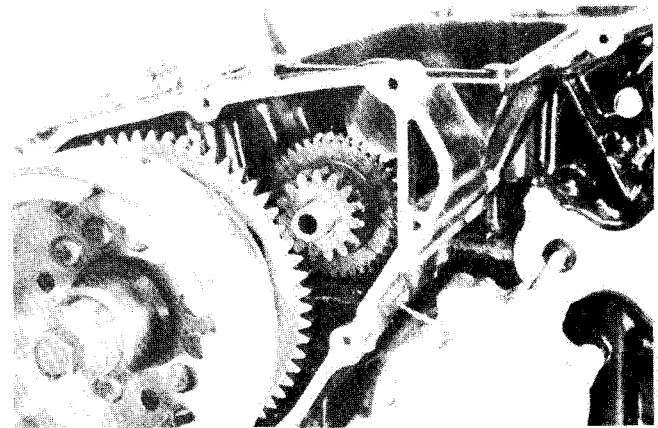

- Using a rotor holder ①, remove the rotor securing bolt.

09930-44911	Rotor holder
-------------	--------------

- Install a rotor remover attachment ② and sliding hammer assembly ③ into the boss of rotor and remove the rotor with starter clutch assembly while sliding the remover.

**CAUTION:**

Do not hit the rotor with a hammer.

09930-30102	Rotor remover shaft
09930-30180	Attachment E

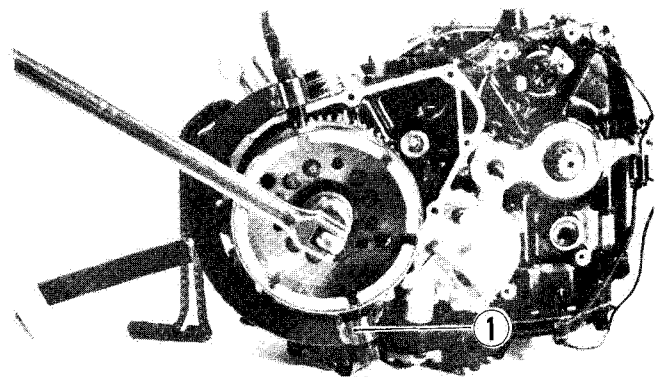

- Using a impact driver, remove the water pump from the lower crankcase.

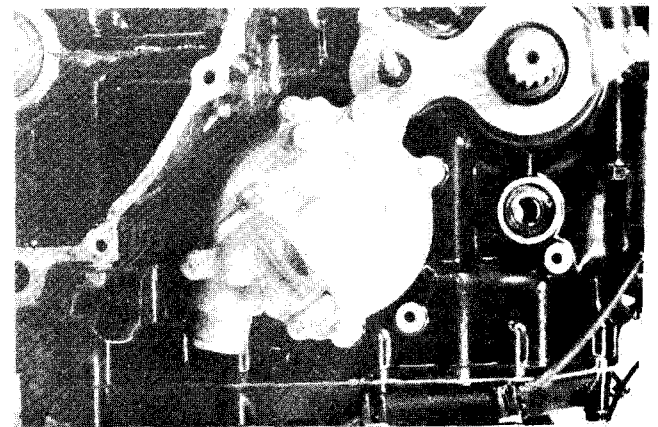
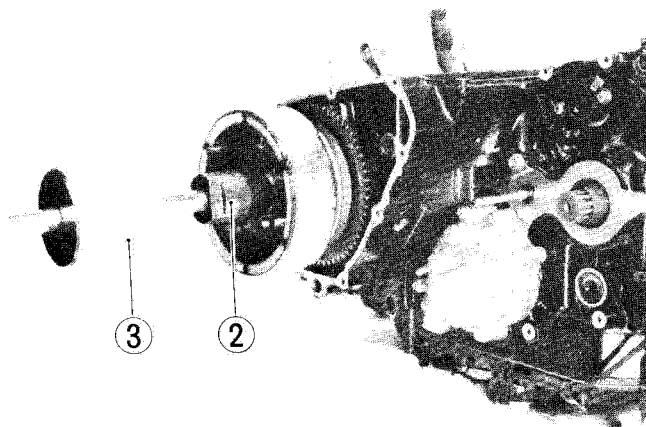

- Flatten the lock portion of the oil seal stopper and remove the oil seal stopper securing bolts.

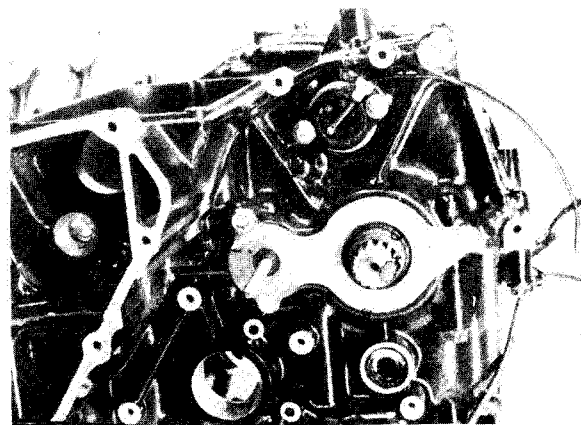

- Unclamp the lead wire and remove the gear position indicator switch body.

**NOTE:**

Do not miss the O-ring, switch contact and its spring.

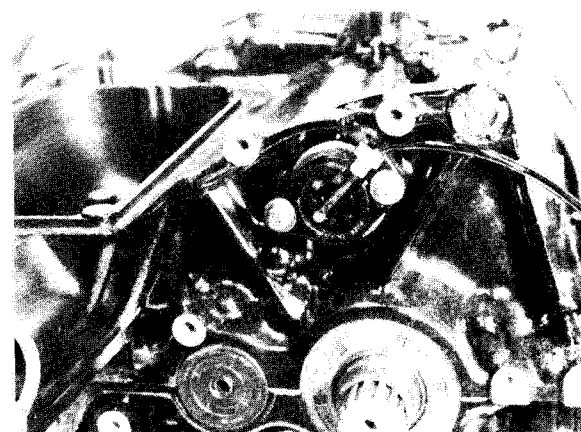

- Remove the crankcase securing bolts from the upper crankcase.

**NOTE:**

Two gaskets are used for oil-tight at the bolts **A**.

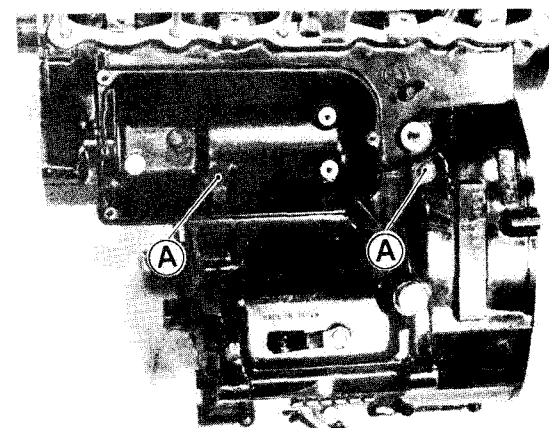

- Turn the engine up side down and remove the oil pan.

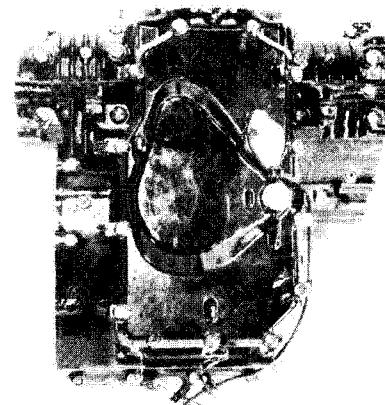

- Remove the oil sump filter, oil guide and oil pressure regulator.

**NOTE:**  
Do not miss the two O-rings located under the oil guide.

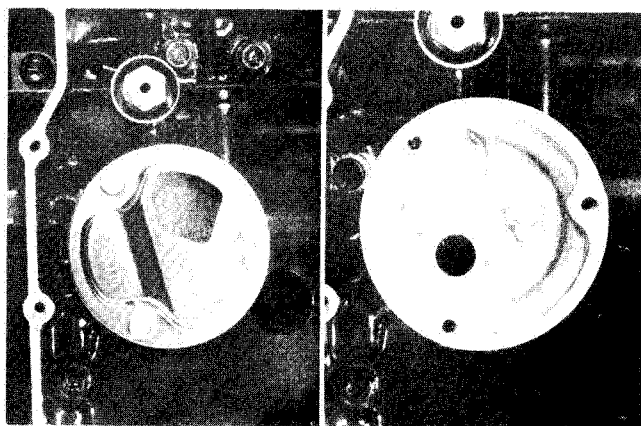

- Remove the crankcase tightening bolts.
- When removing the crankshaft tightening bolts, loosen them in the ascending order of numbers assigned to these bolts.

**NOTE:**  
Two allen bolts are used for securing crankcase at the portion ②.

09914-25811	6 mm T-type hexagon wrench
-------------	----------------------------

- ⓐ : Aluminum washer + signal generator lead-wire clamp
- ⓑ : Aluminum washer
- ⓒ : 4-mm allen bolt

**CAUTION:**  
Make sure that all bolts are removed before using the crankcase separating tool.

- Make sure that all bolts are removed without fail. Hammer lightly the lower crankcase side with a plastic hammer to separate the upper and lower crankcase halves and then lift the latter.

**NOTE:**  
To separate the crankcases is made easier by the use of the cylinder disassembling tool

09912-34510	Cylinder disassembling tool
-------------	-----------------------------

**NOTE:**  
Be ware of dropping crankshaft journal bearings and cam chain tensioner dampers.

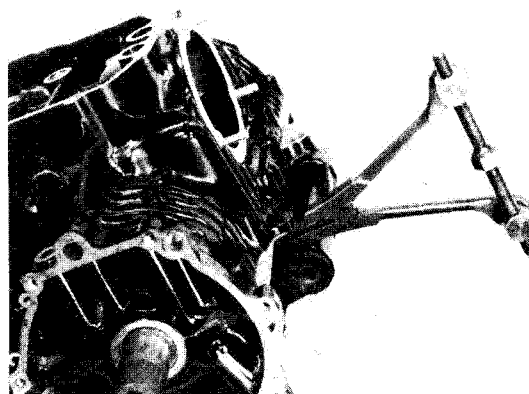
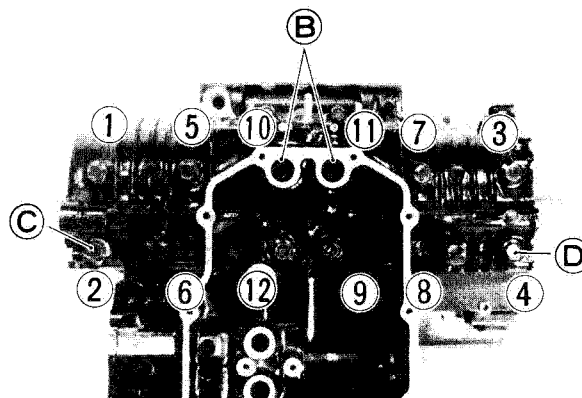
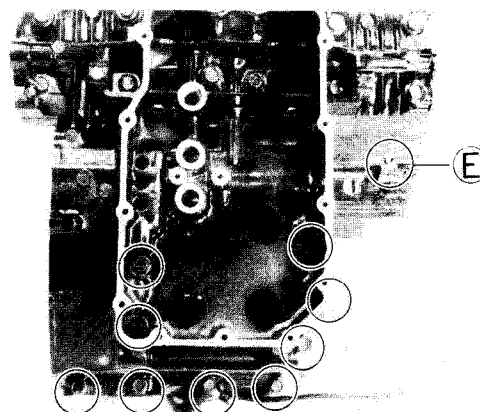

- When removing the lower crankcase from the upper case, make sure that each crankshaft journal bearing position properly.

Ⓐ :O-ring

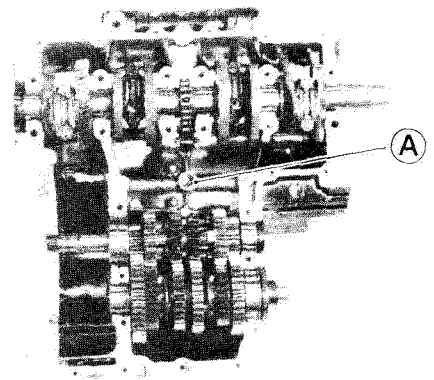

- Remove the countershaft and driveshaft from the case.

**NOTE:**

Be careful not to drop two C-rings.

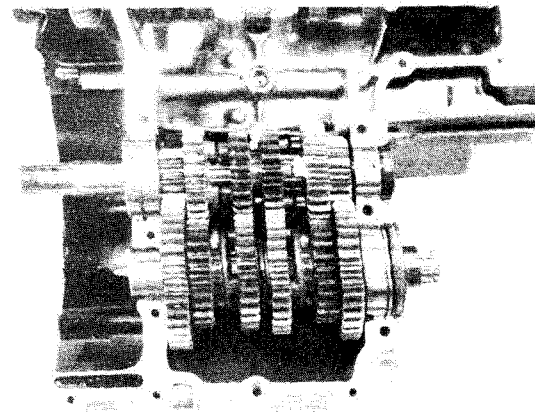

- Remove the crankshaft assembly from the upper crankcase.

**CAUTION:**

Remember, the original position of the crankshaft journal bearings

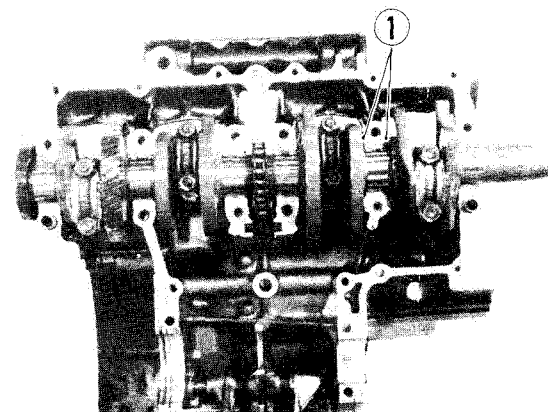

**NOTE:**

Bear in mind that the thrust bearings ① are located between crankshaft and case.

- Remove the cam chain guide and two dampers from the crankcase.

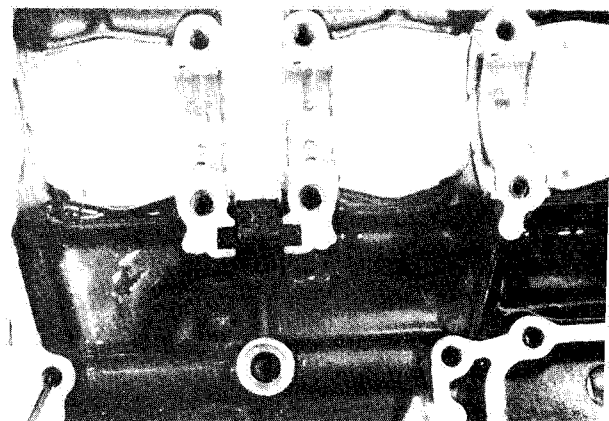

- Remove the neutral stopper housing ①.

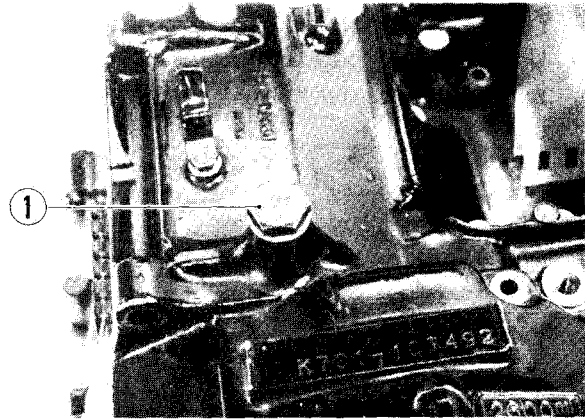

- Remove the gearshift fork shaft stopper screw ② and gearshift cam guide bolt ③.

09900-09003

Impact driver set

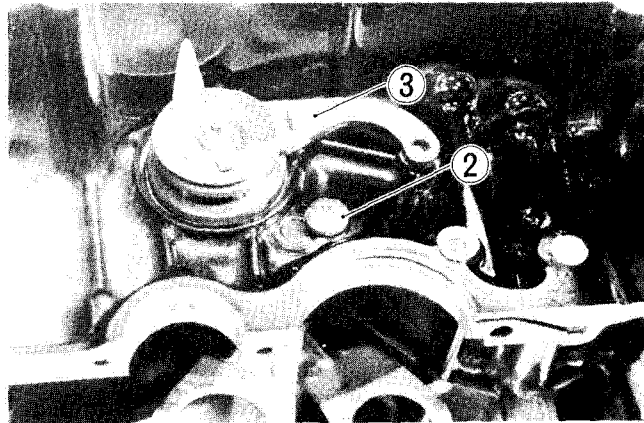

- While holding the gearshift forks by hand, draw out the gearshift fork shaft.

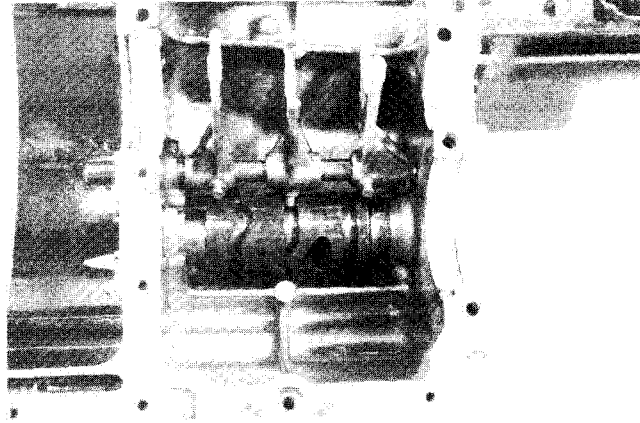

- Draw out the gearshift cam from the upper crankcase.

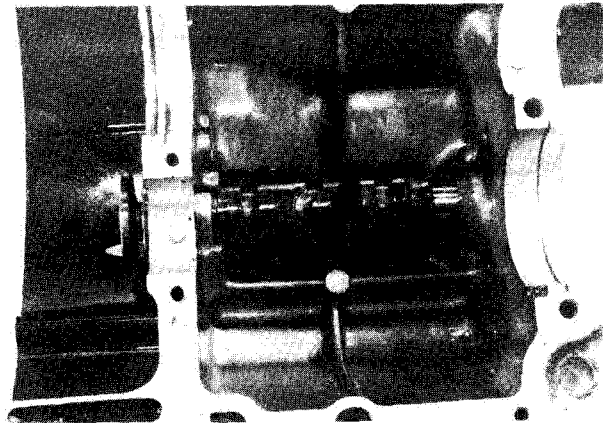

## ENGINE COMPONENTS INSPECTION AND SERVICING CYLINDER HEAD DISASSEMBLY

- Using special tools, compress valve springs and take off two cotter halves ① from valve stem.

09916-14510	Valve lifter
09916-14910	Valve lifter attachment
09916-84510	Tweezers

- Take out the spring retainer, inner and outer springs.
- Pull out the valve from the other side.

### CAUTION:

Be sure to identify each removed part as to its location, and lay the parts out in groups designated as "No. 1 cylinder", "No. 2 cylinder", "Exhaust", "Inlet", "R" and "L", so that each will be restored to the original location during assembly.

### NOTE:

Removal of valves completes ordinary disassembling work. If valve guides have to be removed for replacement after inspecting related parts, carry out the steps shown in valve guide servicing.

- Remove the rocker arm shaft ②, rocker arm and spring.

Rocker arm shaft tightening torque	25 – 30 N·m (2.5 – 3.0 kg·m)
---------------------------------------	---------------------------------

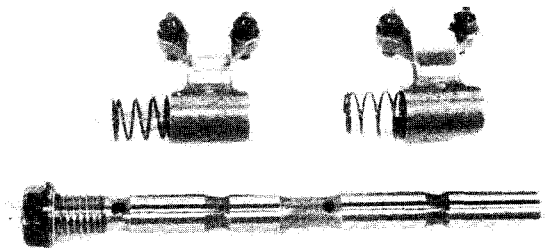
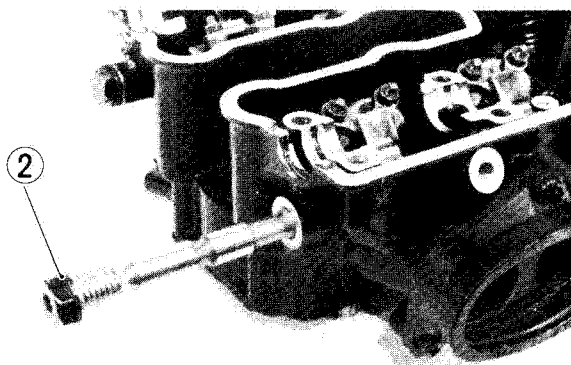
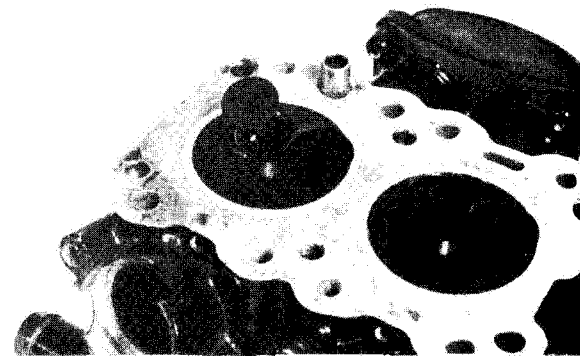
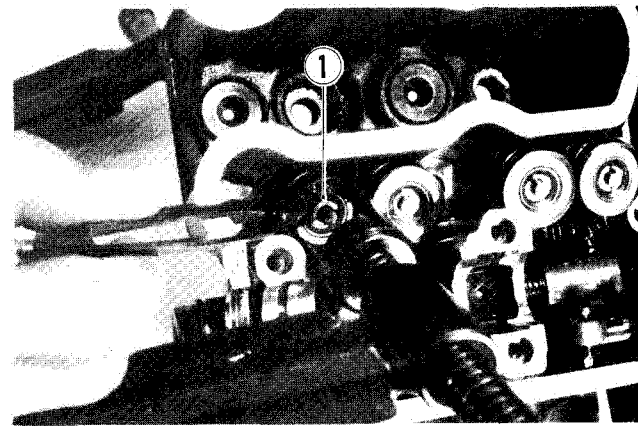
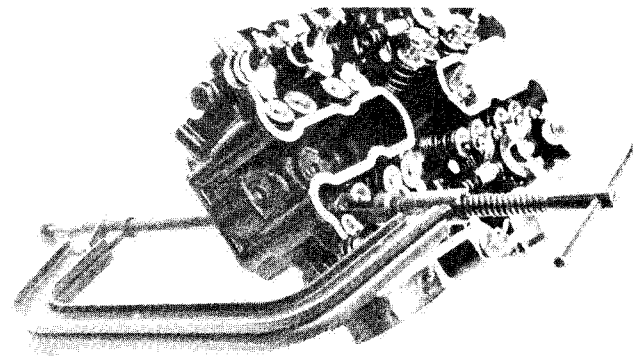

## CYLINDER HEAD DISTORTION

- Decarbonize the combustion chambers.
- Check the gasketed surface of the cylinder head for distortion with a straightedge and thickness gauge, taking a clearance reading at several places indicated. If the largest reading at any position of the straightedge exceeds the limit, replace the cylinder head.

09900-20803	Thickness gauge
Service Limit	0.2 mm

### NOTE:

Do not put the straightedge on the valve when reading the distortion.

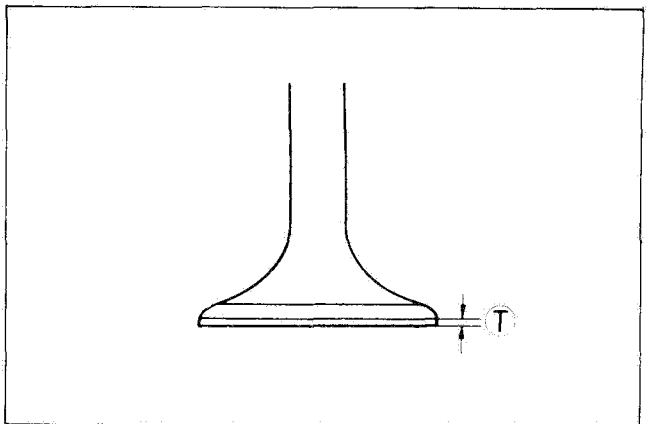
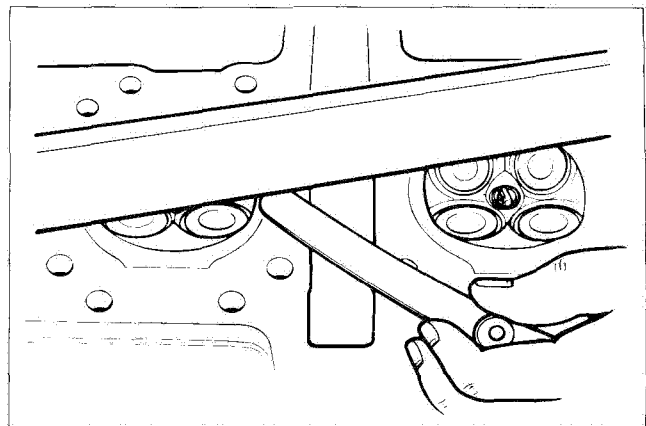
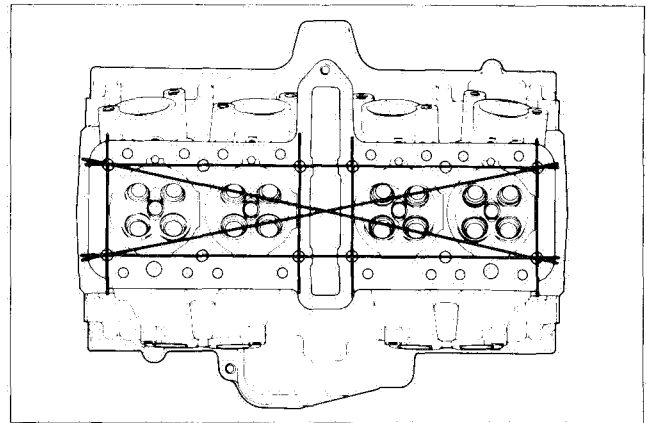

## VALVE FACE WEAR

- Visually inspect each valve for wear of its seating face. Replace any valve with an abnormally worn face.
- The thickness  $T$  decreases as the wear of the face advances. Measure the thickness and, if the thickness is found to have been reduced to the limit, replace it.

Service Limit	0.5 mm
---------------	--------

## VALVE STEM RUNOUT

- Support the valve with "V" blocks, as shown, and check its runout with a dial gauge. The valve must be replaced if the runout exceeds the limit.

09900-21303	V-block set
09900-20606	Dial gauge (1/100 mm)
09900-20701	Magnetic stand
Service Limit	0.05 mm

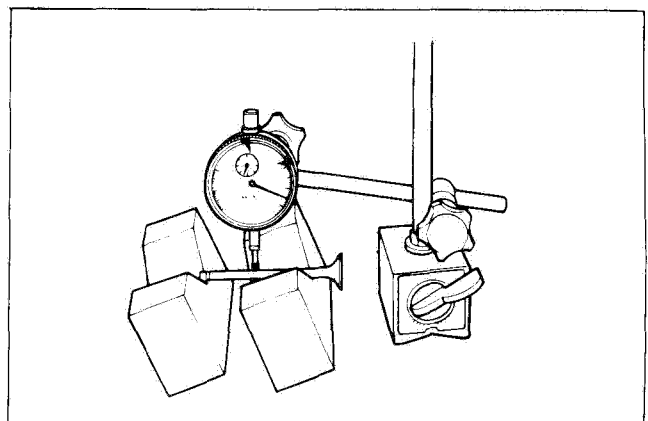



**VALVE HEAD RADIAL RUNOUT**

- Place the dial gauge at right angles to the valve head face, and measure the valve head radial runout.

If it measures more than limit, replace the valve.

Service Limit	0.03 mm
---------------	---------

**VALVE GUIDE — VALVE STEM CLEARANCE**

Measure the clearance in two directions "X" and "Y", perpendicular to each other, by rigging up the dial gauge as shown. If the clearance measured exceeds the limit, specified below, then determine whether the valve or the guide should be replaced to reduce the clearance to the standard range:

Valve	Service Limit
Intake valves	0.35 mm
Exhaust valves	0.35 mm

**VALVE STEM WEAR**

If the valve stem is worn down to the limit, as measured with a micrometer, where the clearance is found to be in excess of the limit indicated replace the valve, if the stem is within the limit, then replace the guide. After replacing valve or guide, be sure to recheck the clearance.

09900-20205	Micrometer (0 – 25 mm)
-------------	---------------------------

Valve	Standard
Intake valves	4.960 – 4.975 mm
Exhaust valves	4.945 – 4.960 mm

**VALVE GUIDE SERVICING**

- Using valve guide remover (1), drive the valve guide out toward intake or exhaust camshaft side.

09916-44310	Valve guide remover
-------------	---------------------

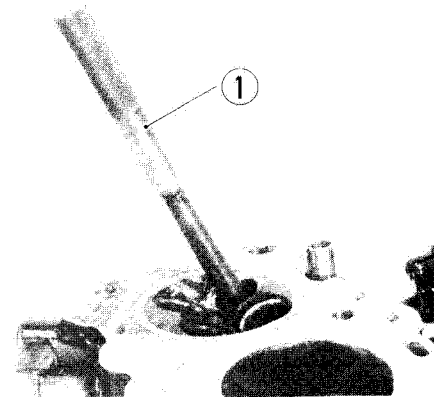
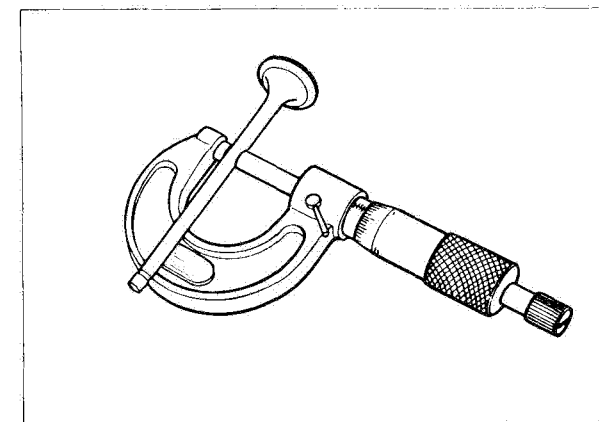
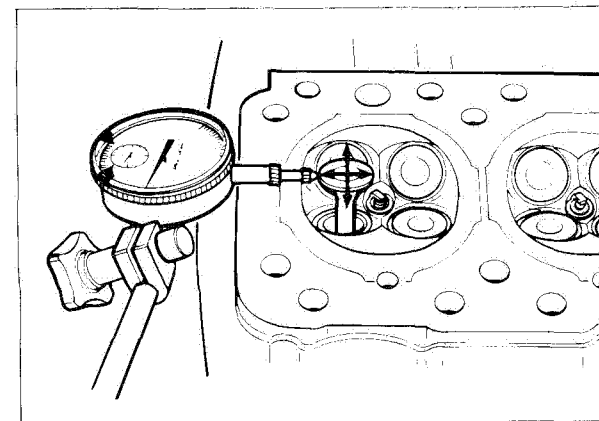
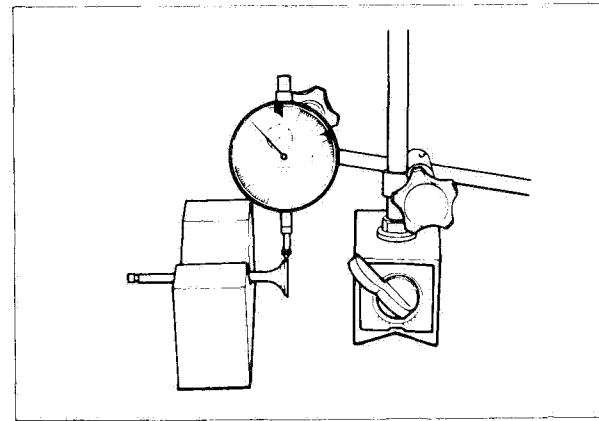

**NOTE:**

- \* Discard the removed valve guide subassemblies.
- \* Only oversized valve guide is available.

- Re-finish the valve guide holes in cylinder head with a 10.8 mm reamer.

09916-34580	Valve guide hole reamer
09916-34541	Reamer handle

- Fit a ring to each valve guide. Be sure to use new rings and valve guides. Use of rings and valve guides removed during disassembly is prohibited. Remember that both valve guides for intake and exhaust and both oil seals are identical in shape.

11115-33472	Valve guide
09289-05008	Valve guide oil seal

- Oil the stem hole of each valve guide and drive the guide into the guide hole with the valve guide remover and attachment.

09916-44310	Valve guide remover
09916-44920	Valve guide installer attachment

**CAUTION:**

Failure to oil the valve guide hole before driving the new guide into place may result in a damaged guide or head.

- Install valve spring lower seats ①. Be careful not to confuse the lower seats with the spring retainer ②.
- After fitting all valve guides, refinish their guiding bores with a 5.0 mm reamer. Be sure to clean and oil the guide after reaming.

09916-34570	Valve guide reamer
09916-34541	Reamer handle

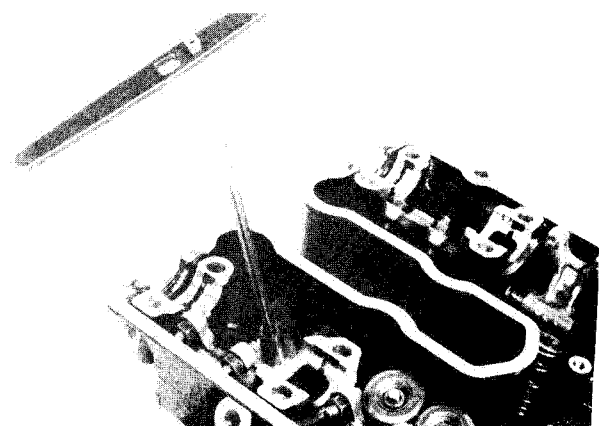
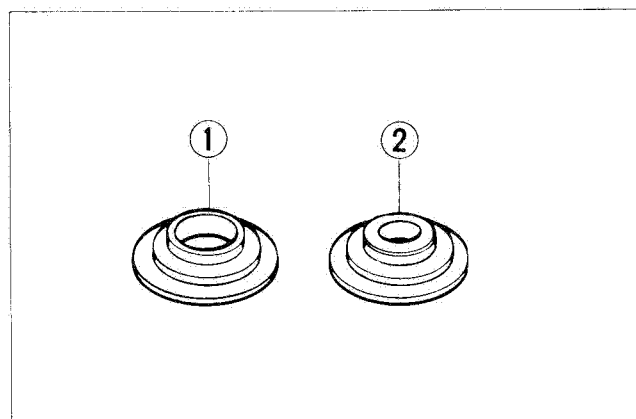
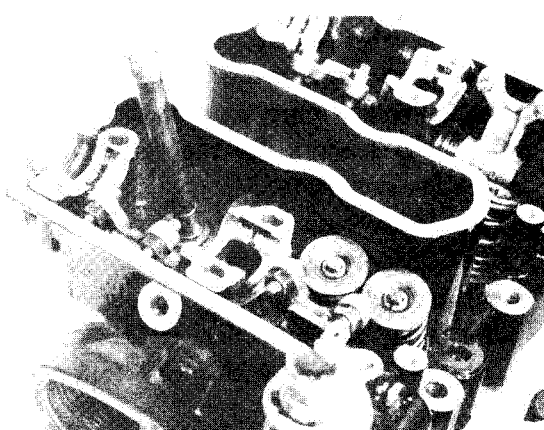
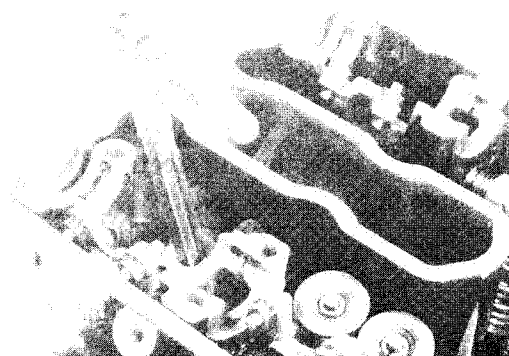

- Oil each oil seal, and drive them into position with the valve guide remover.

09916-44310

Valve guide remover

**NOTE:**

Do not use the oil seals removed in disassembly: use new seals.

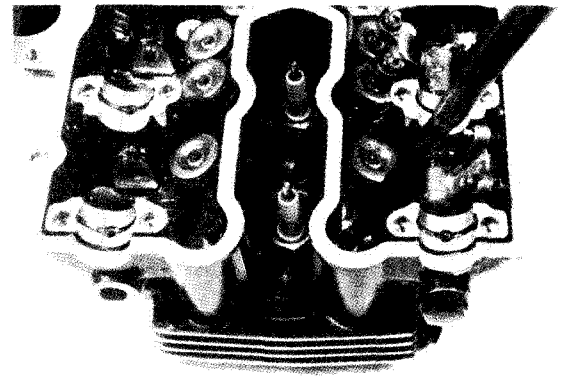
**VALVE SEAT WIDTH**

- Coat the valve seat with Prussian blue uniformly. Fit the valve and tap the coated seat with the valve face in a rotating manner, in order to obtain a clear impression of the seating contact. In this operation, use the valve lapper to hold the valve head.
- The ring-like dye impression left on the valve face must be continuous-without any break – and, in addition to this requirement, the width of the dye ring, which is the visualized seat “width”, must be within the following specification:

**Valve seat width**

Seat width	Standard
Ⓜ	0.9 – 1.1 mm

If either requirement is not met, correct the seat by servicing it as follows:

**VALVE SEAT SERVICING**

The valve seats for both the intake and exhaust valves are machined to two different angles. The seat contact surface is cut 45° and the area above the contact surface (closest to the combustion chamber) is cut to 15°.

09916-21110	Valve seat cutter set
09916-20410 (Intake)	Valve seat cutter head (15°) (N-134)
09916-24470	Valve seat cutter head (45°) (N-131)
09916-24460 (Exhaust)	Valve seat cutter head (15°) (N-130)

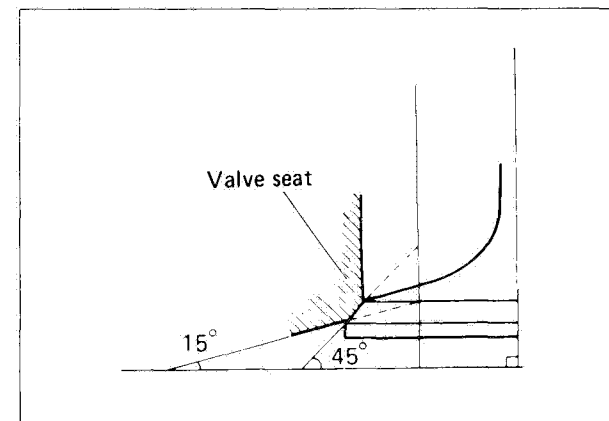
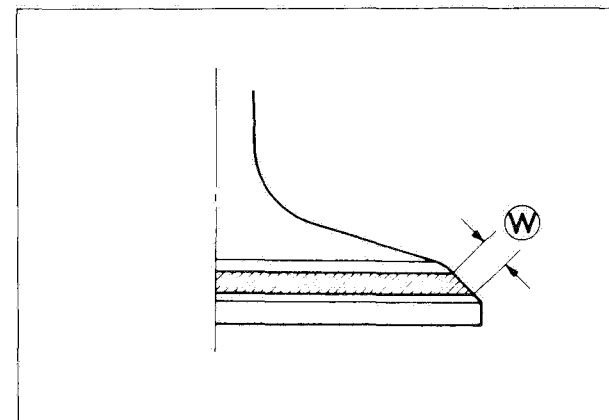
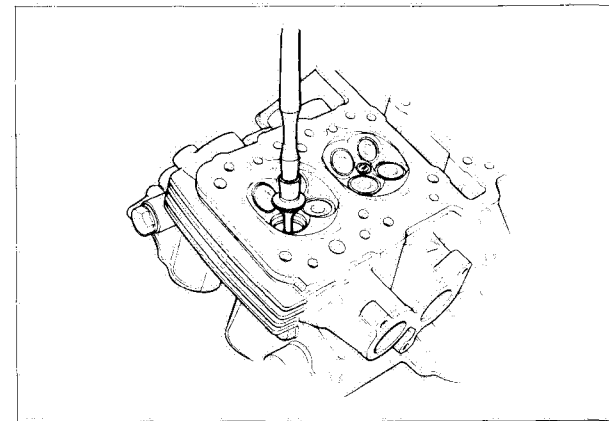

**NOTE:**

The valve seat contact area must be inspected after each cut.

- Insert the solid pilot ① with a slight rotation. Seat the pilot snugly. Install the 45° cutter, attachment and T handle.
- Using the 45° cutter, descale and cleanup the seat with one or two turns.
- Inspect the seat by the previously described seat width measurement procedure. If the seat is pitted or burned, additional seat conditioning with the 45° cutter is required.

**NOTE:**

Cut only the minimum amount necessary from the seat to prevent the possibility of the valve stem becoming too close to the cam for correct valve clearance adjustment.

If the contact area is too high on the valve, or if it is too wide, use a 15° cutter to lower and narrow the contact area.

If the contact area is too low or too narrow, use the 45° cutter to raise and widen the contact area.

- After the desired seat position and width is achieved, use the 45° cutter very lightly to clean up any burrs caused by the previous cutting operations. DO NOT use lapping compound after the final cut is made. The finished valve seat should have a velvety smooth finish and not a highly polished or shiny finish. This will provide a soft surface for the final seating of the valve which will occur during the first few seconds of engine operation.
- Clean and assemble the head and valve components. Fill the intake and exhaust ports with gasoline to check for leaks. If any leaks occur, inspect the valve seat and face for burrs or other things that could prevent the valve from sealing.

**NOTE:**

- \* Always use extreme caution when handling gasoline.
- \* After servicing the valve seats, be sure to adjust the valve clearance after the cylinder head has been reinstalled. (see page 2-6)

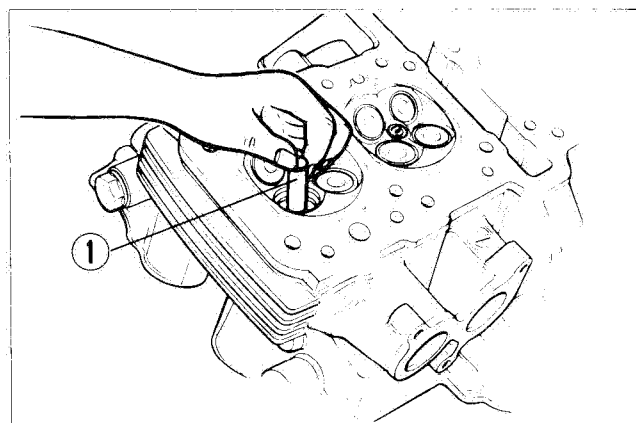

Contact area too high and too wide on face of valve

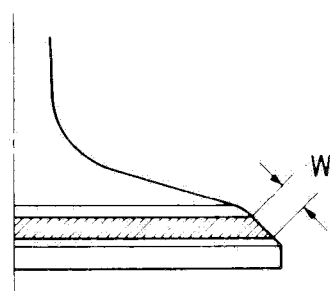

Contact area too low and too narrow on face of valve

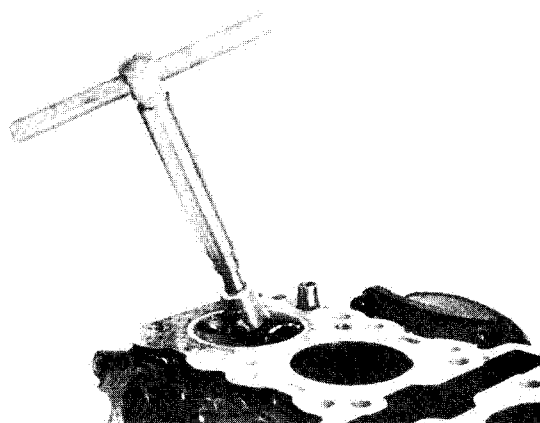
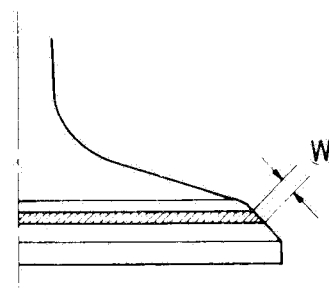

**CAUTION:**

- \* Refacing valve stem end face is permissible where the length ① will not be reduced to less than 2.9 mm. If this length becomes shorter than 2.9 mm, then the valve must be replaced.
- \* After installing the valve whose stem end has been ground off as above, check that the face ② of valve stem end is above the valve cotter ③.

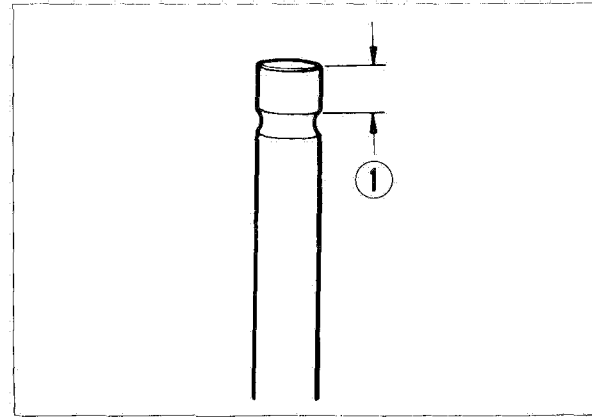
**VALVE SPRINGS**

- The force of the two coil springs keeps the valve seat tight. Weakened springs result in reduced engine power output, and often account for the chattering noise coming from the valve mechanism.
- Check the springs for strength by measuring their free lengths and also the force required to compress them. If the limit indicated is exceeded by the free length reading or if the measured force does not fall within the range specified, replace with a SUZUKI spring.

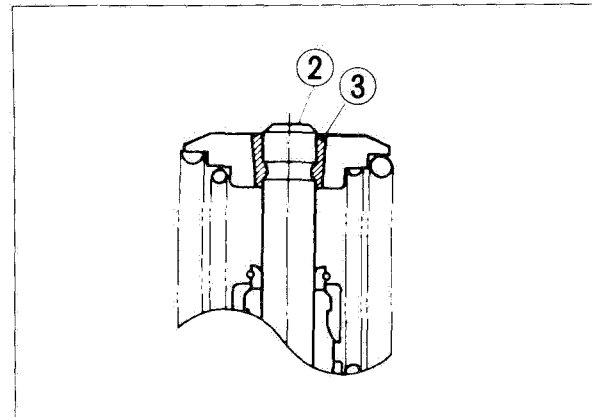
**CAUTION:**

Replace both of the valve springs, inner and outer, at a time, if any one of these is found to be beyond the limit.

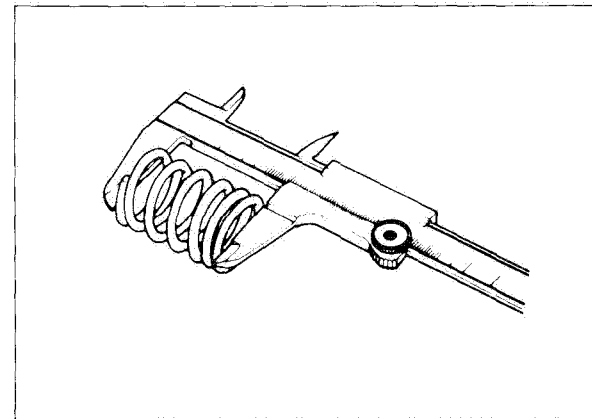
**Valve spring free length**

Spring		Service Limit
INTAKE	INNER	31.6 mm
	OUTER	35.2 mm
EXH AUST	INNER	31.1 mm
	OUTER	35.2 mm

**Valve spring tension**

Spring	Standard
INNER	5.0 – 5.9 kg/28 mm
OUTER	8.4 – 9.8 kg/31.5 mm

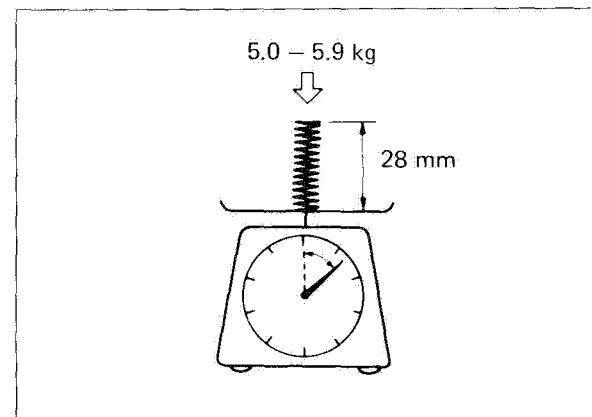

## REASSEMBLY

- Insert the valves, with their stems coated with high quality molybdenum disulfide lubricant (SUZUKI MOLY PASTE) all round and along the full stem length without any break.

### CAUTION:

When inserting each valve, take care not to damage the lip of the stem seal.

99000-25140

SUZUKI Moly Paste

- Install the valve springs with the small pitch portion (A) down.
  - (B) : Large-pitch portion.

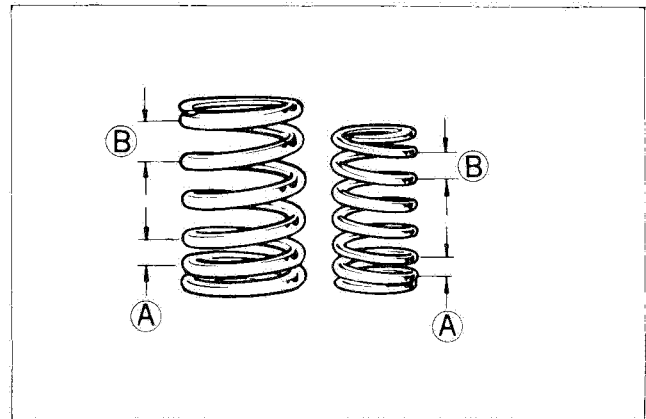
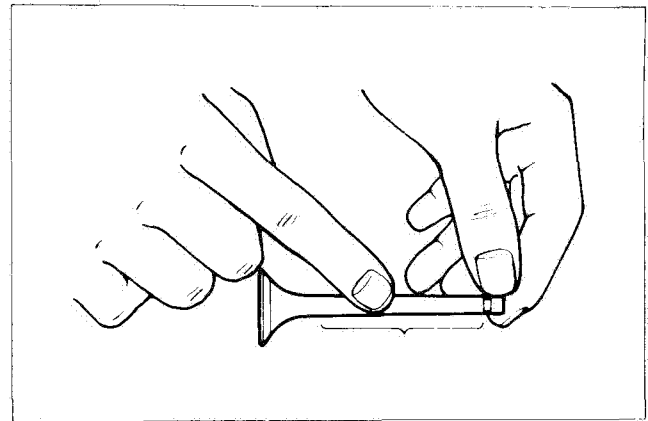

- Put on the upper valve seat and, using the valve lifter, press down the springs, fit the two cotter halves to the stem end, and release the lifter to allow the cotter (1) to wedge in between seat and stem. Be sure that the rounded lip (2) of the cotter fits snugly into the groove (3) in the stem end.

### CAUTION:

Be sure to restore each spring, valve and spring retainer to their original positions.

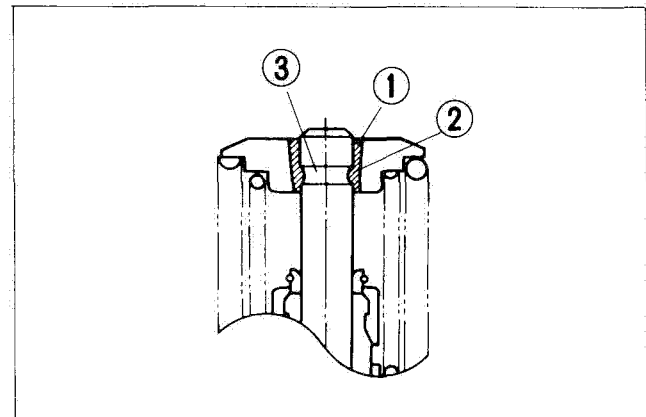

## CAMSHAFT

Both camshafts should be checked for the wear of cams and journals if the engine has been noted as giving abnormal noise or vibration or to lack power output. Any of these conditions may be caused by cam or camshafts journal worn down to the service limit.

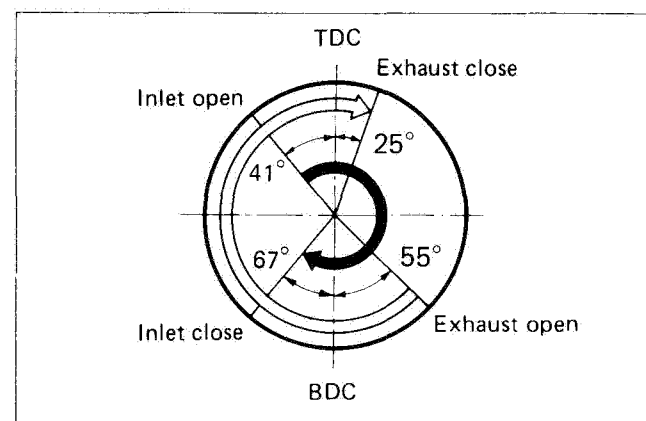

- The exhaust camshaft can be distinguished from that of the intake by the embossed letters "EX" (for exhaust) as against letters "IN" (for intake). The right end can be distinguished by the notch from the left end.

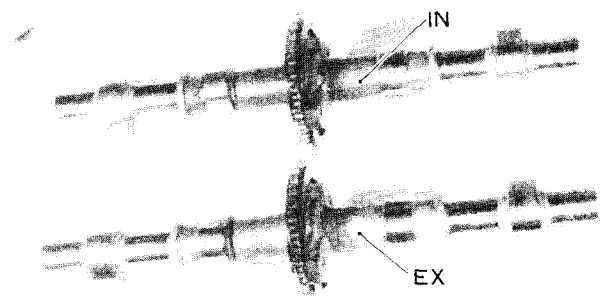

## CAM WEAR

- Worn-down cams are often the cause of mistiming valve operation resulting in reduced power output. The limit of cam wear is specified for both intake and exhaust cams in terms of cam height  $\text{H}$ , which is to be measured with a micrometer. Replace camshafts if found worn down to the limit.

### Cam height

Height $\text{H}$	Service Limit
Intake cams	34.61 mm
Exhaust cams	33.84 mm

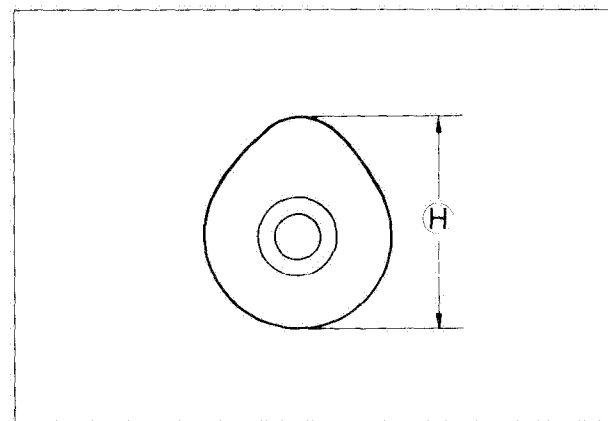

## CAMSHAFT JOURNAL WEAR

- Determine whether or not each journal is worn down to the limit by measuring the running clearance with the camshaft installed in place. Use plastigauge ① to read the clearance at the widest portion, which is specified as follows:

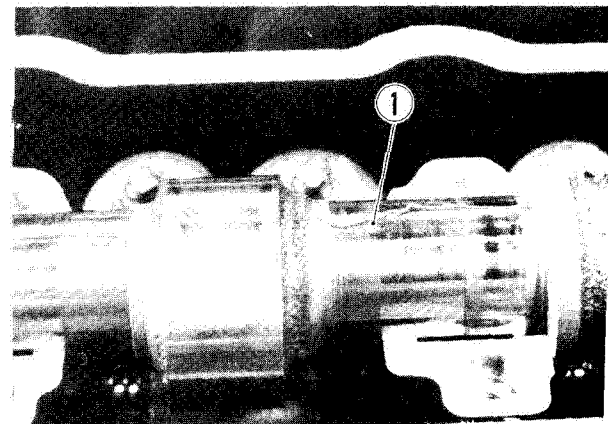

### Camshaft journal oil clearance (IN & EX)

Service Limit	0.15 mm
---------------	---------

#### NOTE:

Install each holder to their original positions.

09900-22301	Plastigauge
-------------	-------------

- Tighten the camshaft holder bolts evenly and diagonally to the specified torque.

Tightening torque	10 – 14 N·m (1.0 – 1.4 kg·m)
-------------------	---------------------------------

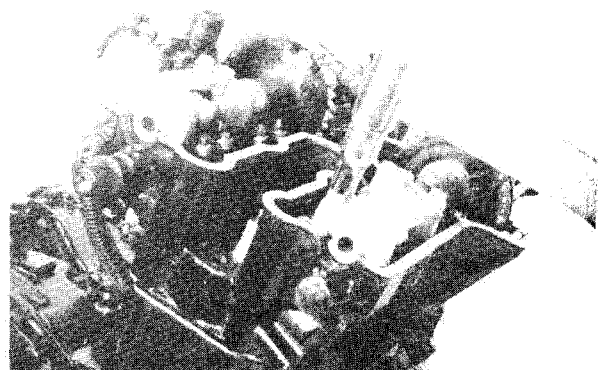

- Remove the camshaft holders, and read the width of compressed plastigauge with envelope scale. This measurement should be taken at the widest part.

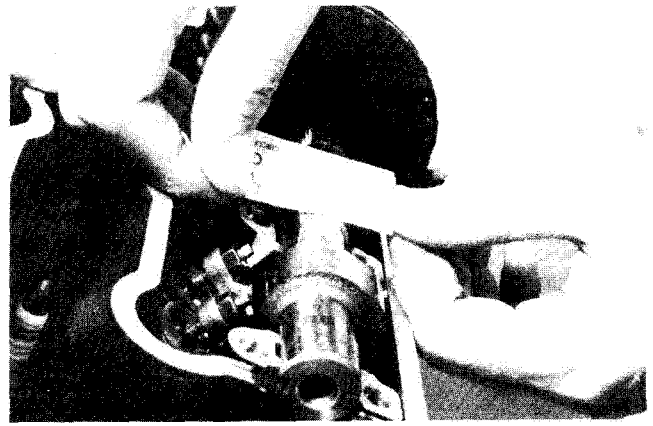

- If the camshaft journal clearance measured exceeds the limit, measure the inside diameter of camshaft bearing holder and outside diameter of the camshaft journal. Replace whichever the difference from specification is greater.

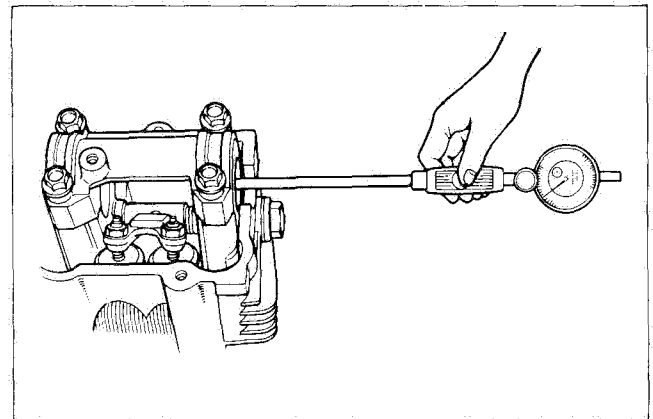

09900-20205	Micrometer (0 – 25 mm)
	Standard
Journal holder I.D. (In & Ex)	22.012 – 22.025 mm
Camshaft journal O.D. (In & Ex)	21.959 – 21.980 mm

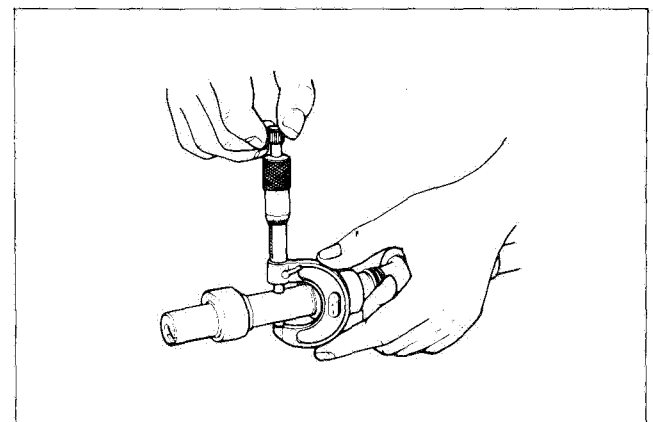

### CAMSHAFT RUNOUT

- Measure the runout with a dial gauge. Replace the camshaft if the runout exceeds the limit.

#### Camshaft runout (IN & EX)

Service Limit	0.10 mm
---------------	---------

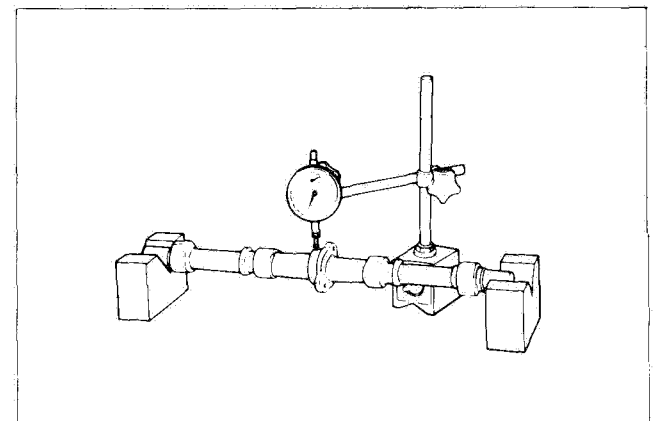



## CAM SPROCKET REASSEMBLY

- It is very important that each sprocket be positioned angularly on its camshaft as illustrated. Its correct position is determined by arrow mark "3" (on INTAKE sprocket) or arrow marks "1" and "2" (on EXHAUST sprocket) located (as shown) in reference to the notch ① in the camshaft end.

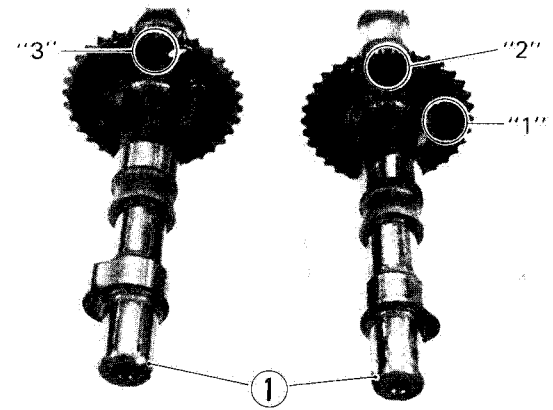

- Apply THREAD LOCK SUPER "1303" (99000-32030) to threads of bolts, and tighten them of the following torque value:

99000-32030	Thread lock super "1303"
Tightening torque	24 – 26 N·m (2.4 – 2.6 kg-m)

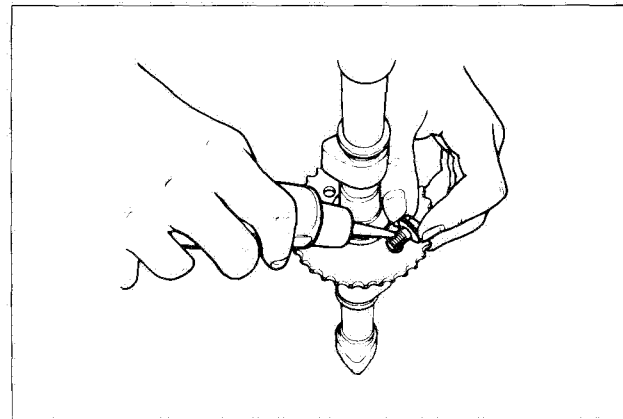

## CAM CHAIN TENSIONER

### INSPECTION

- Turn the cylinder shaft ① with a screw driver in the clockwise direction, and move the push rod ② in place to see if it slides smoothly. If any stickiness is noted, replace the chain tensioner assembly with a new one.

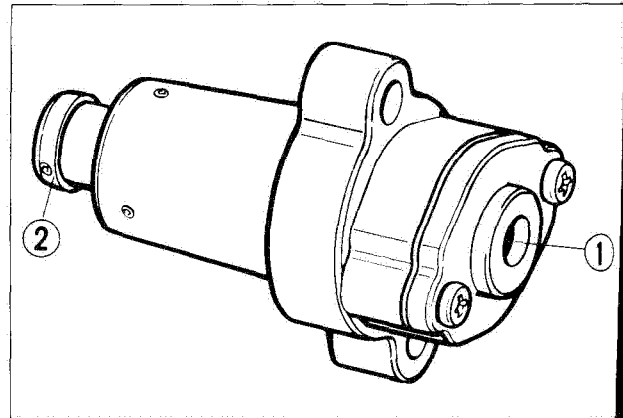

## CAM CHAIN 20-PITCH LENGTH

Pull the chain tight to remove any slack, then using vernier calipers, measure the 20-pitch length of cam chain. If it measures more than limit, replace the cam chain.

Service Limit	157.80 mm
---------------	-----------

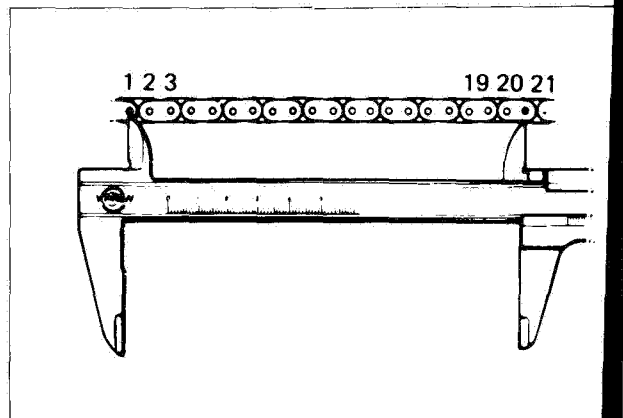

## CAM CHAIN GUIDE

### NOTE:

When replacing following chain guides, apply SUZUKI Thread lock "1342" to screws thread.

99000-32050	Thread lock super "1342"
-------------	--------------------------

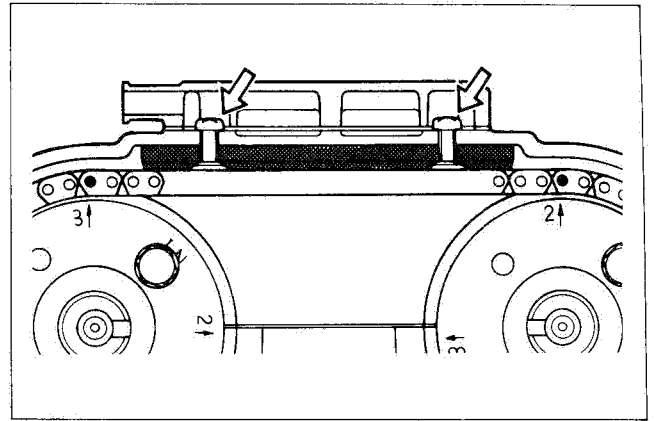

## CYLINDER DISTORTION

Check the gasketed surface of the cylinder for distortion with a straightedge and thickness gauge, taking a clearance reading at several places indicated. If the largest reading at any position of the straightedge exceeds the limit, replace the cylinder.

### Cylinder distortion

Service Limit	0.20 mm
---------------	---------

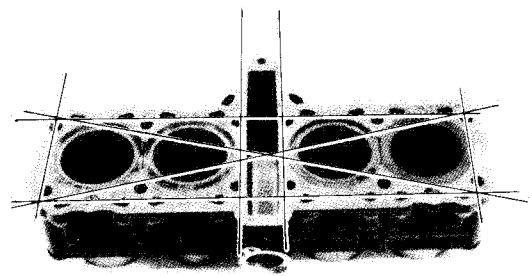

## CYLINDER BORE

Measure the cylinder bore diameter at six places. If any one of the measurements exceeds the limit, overhaul the cylinder and replace the piston with an oversize, or replace the cylinder. Once the re boring is done on any one cylinder which measurements is beyond the limit, the remaining cylinders must be also rebored accordingly. Otherwise the imbalance might causes excess vibration.

### Cylinder bore

Service Limit	53.100 mm
---------------	-----------

09900-20508	Cylinder gauge set
-------------	--------------------

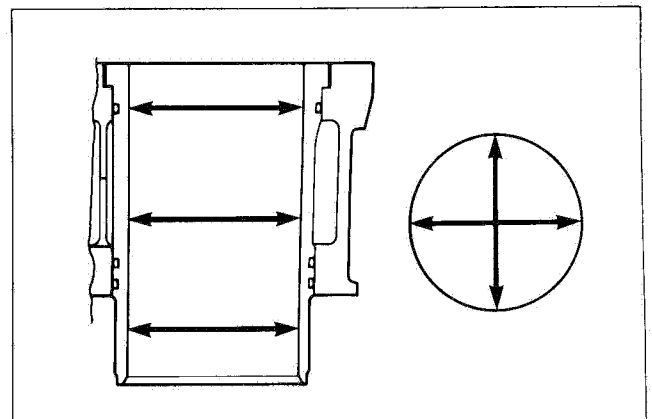
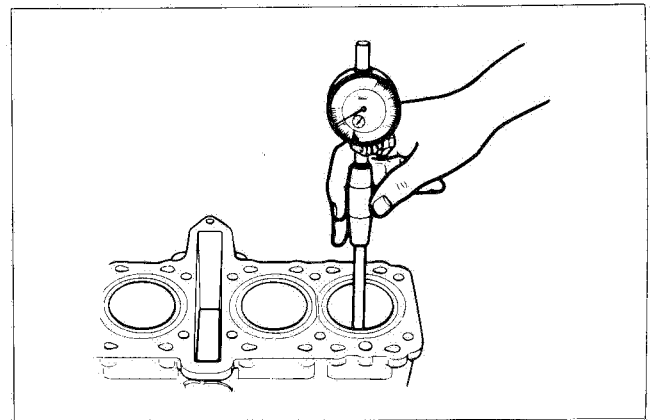

**PISTON DIAMETER**

Using a micrometer, measure the piston outside diameter at the place shown in Fig. If the measurement is less than the limit, replace the piston.

Piston oversize	0.5, 1.0 mm
Service Limit	52.885 mm
09900-20203	Micrometer (50 – 75 mm)

**PISTON-CYLINDER CLEARANCE**

As a result of the above measurement, if the piston clearance exceeds the following limit, overhaul the cylinder and use an oversize piston, or replace both cylinder and piston.

Service Limit	0.120 mm
---------------	----------

**PISTON RING-GROOVE CLEARANCE**

Using a thickness gauge, measure the side clearances of the 1st and 2nd rings. If any one of the clearances exceeds the limit, replace both piston and piston rings.

09900-20803	Thickness gauge
-------------	-----------------

**Piston ring—groove clearance**

Piston ring	Service Limit
1st	0.18 mm
2nd	0.15 mm

**Piston ring groove width**

Piston ring	Standard
1st	0.805 – 0.830 mm
2nd	1.010 – 0.030 mm
Oil	2.010 – 2.030 mm

**Piston ring thickness**

Piston ring	Standard
1st	0.770 – 0.795 mm
2nd	0.970 – 0.990 mm

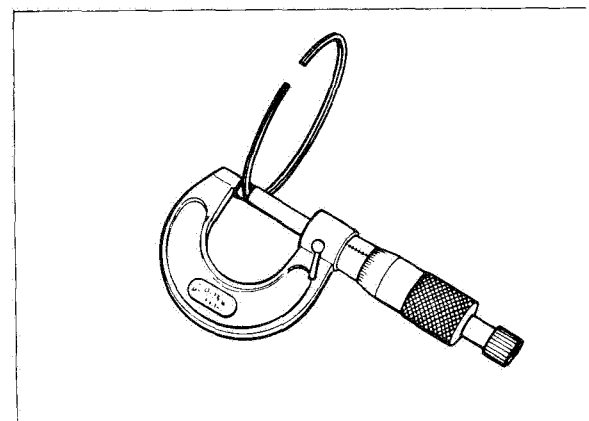
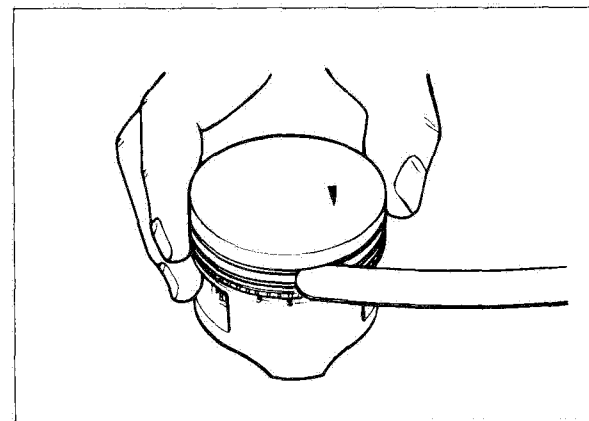
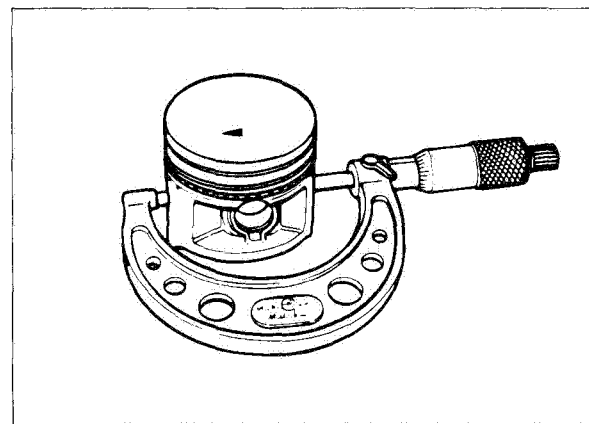
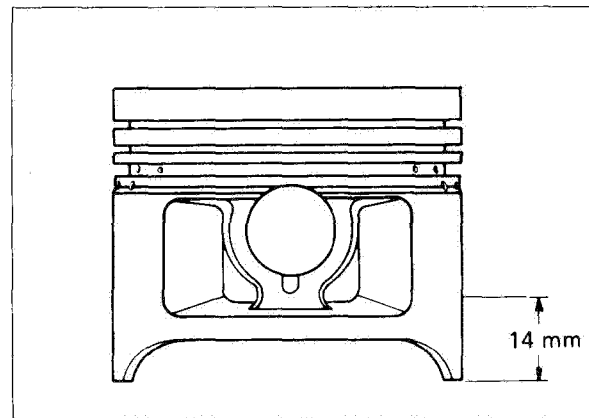

## PISTON RING FREE END GAP AND PISTON RING END GAP

Before installing piston rings, measure the free end gap of each ring using vernier calipers. Next, fit the ring in the cylinder, and measure each ring end gap using a thickness gauge.

If any ring has an excess end gap, replace the ring.

### Piston ring free end gap

Piston ring	Service Limit
1st	5.2 mm
2nd	4.8 mm

### Piston ring end gap

Piston ring	Service Limit
1st & 2nd	0.70 mm

09900-20803	Thickness gauge
-------------	-----------------

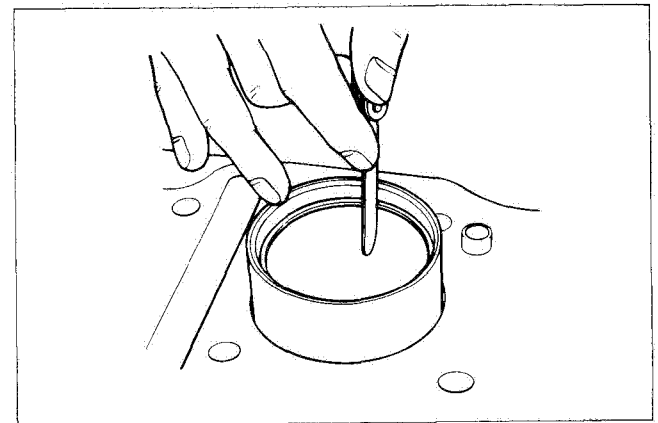
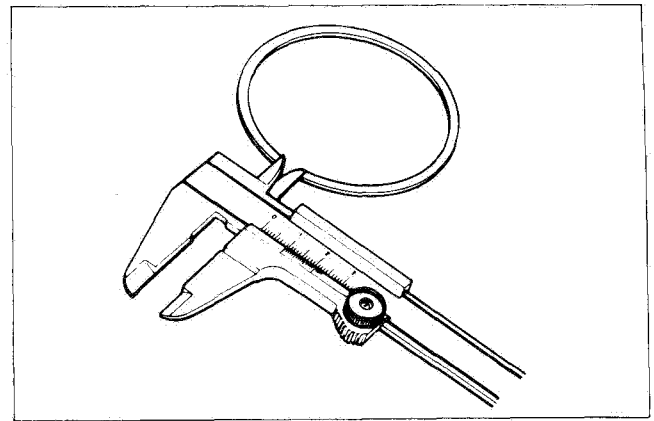

- **Oversize piston rings**

The following two types of oversize piston rings are used. They bear the following identification numbers.

	1st	2nd
0.5 mm	50	50
1.0 mm	100	100

- **Oversize oil rings**

The following two types of oversize oil rings are available as optional parts. They bear the following identification marks.

SIZE	COLOR
STD	Painted Blue
0.5 mm O.S.	Painted Red
1.0 mm O.S.	Painted yellow

- **Oversize side rail**

Just measure out side diameter to identify the size.

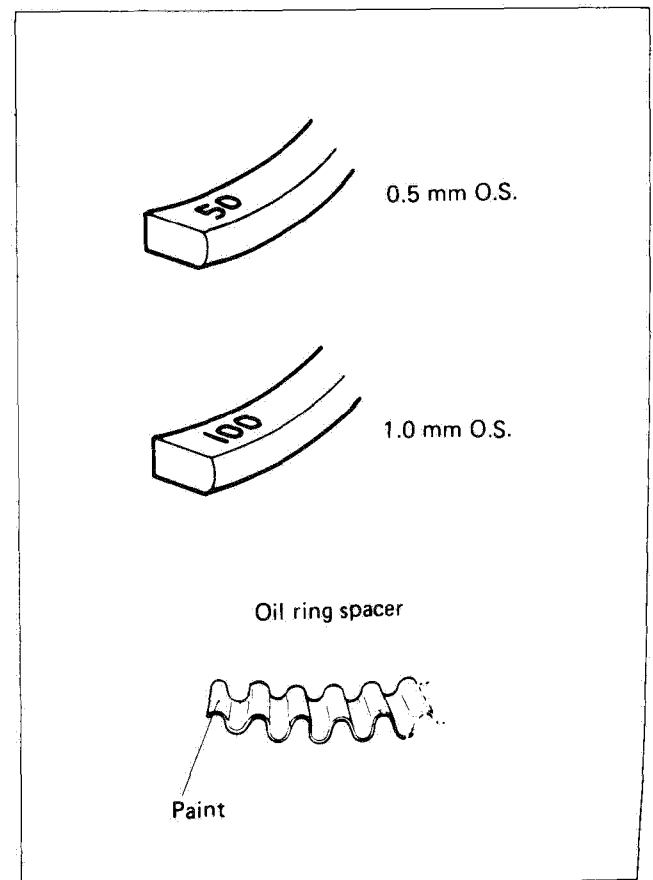

### PISTON PIN AND PIN BORE

Using a small bore gauge, measure the piston pin bore inside diameter, and using a micrometer, measure the piston pin outside diameter. If the reading exceeds the following limit, replace both piston and piston pin.

#### Piston pin bore I.D.

Service Limit	14.030 mm
09900-22401	Small bore gauge (10 – 18 mm)

Using a micrometer, measure the piston pin outside diameter at three positions.

#### Piston pin O.D.

Service Limit	13.980 mm
09900-20205	Micrometer (0 – 25 mm)

### CONNECTING ROD SMALL END BORE I.D.

Using a small bore gauge, measure the connecting rod small end inside diameter.

#### Connecting rod small end bore I.D.

Service Limit	14.040 mm
---------------	-----------

- If the connecting rod small end bore inside diameter exceeds the abovementioned limit, replace connecting rod.

### CONNECTING ROD BIG END THRUST CLEARANCE

Check the connecting rod thrust clearance by using thickness gauge. If the clearance exceeds the limit, replace connecting rod or crankshaft.

Service Limit	0.30 mm
---------------	---------

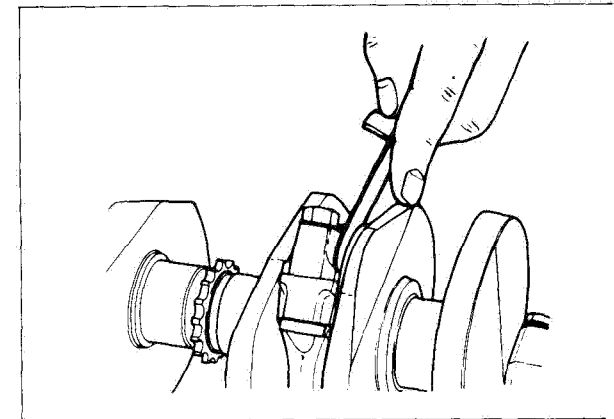
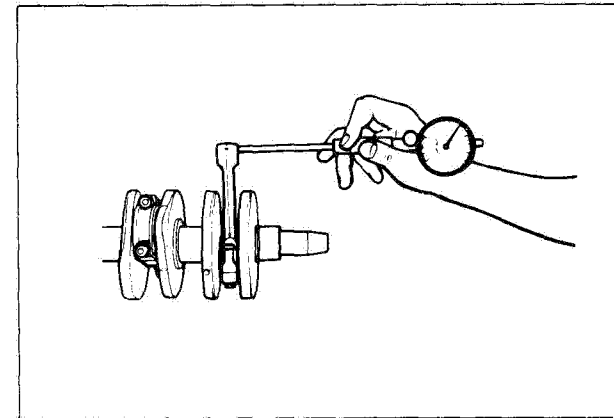
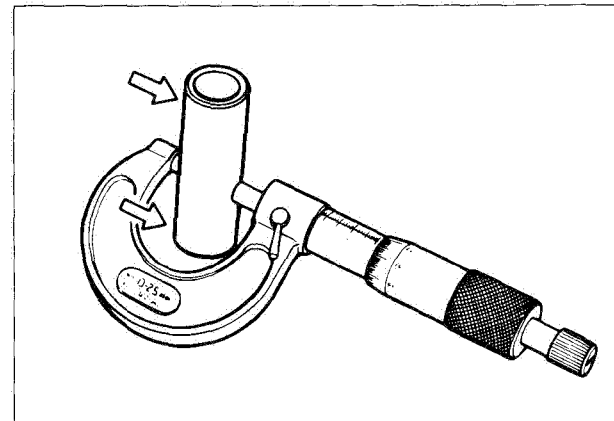
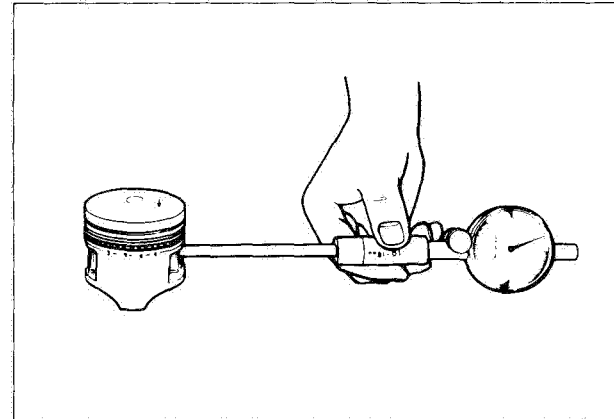

	Standard
Big end width	16.95 – 17.00 mm
Crank pin width	17.10 – 17.15 mm

## CONNECTING ROD-CRANK PIN BEARING SELECTION

- Loosen bearing cap nuts and tap the bolt end lightly with plastic hammer to remove bearing cap.
- Remove rods and mark them to identify the cylinder position.
- Inspect bearing surfaces for any sign of fusion, pitting, burn or flaws. If any, replace them with a specified set of bearings.

### NOTE:

Never try to remove or loosen the connecting rod big end stud, otherwise, it will displace the stud and will not fit the bearing cap properly.

- Place plastigauge ① axially on the crank pin, avoiding the oil hole and at the TDC or BDC side as shown.

09900-22301

Plastigauge

- Tighten the bearing cap with two-step torque values.

### NOTE:

When fitting bearing cap to crank pin, be sure to discriminate between its two ends, front and rear.

Initial tightening torque	12 – 16 N·m (1.2 – 1.6 kg·m)
---------------------------	---------------------------------

Final tightening torque	23 – 27 N·m (2.3 – 2.7 kg·m)
-------------------------	---------------------------------

### NOTE:

Never rotate crankshaft or connecting rod when a piece of Plastigauge is in the clearance.

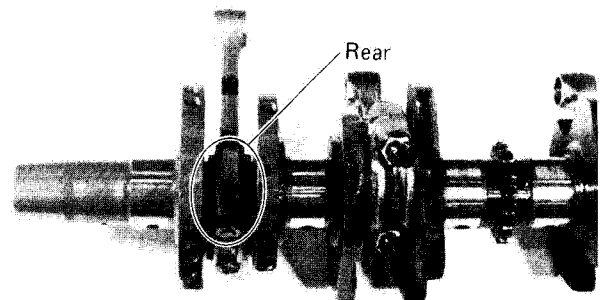
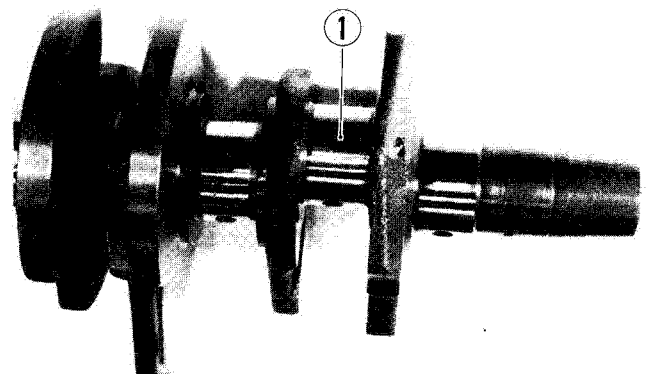
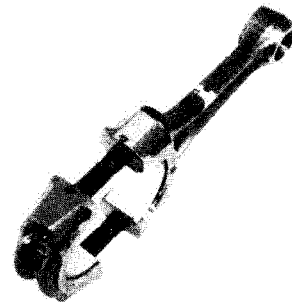
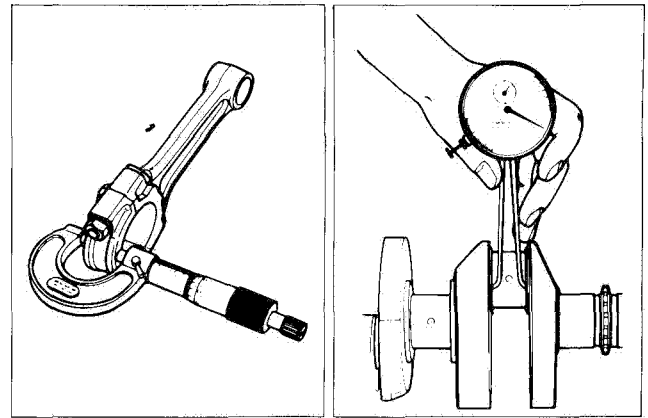

- Remove the caps and measure the width of compressed plastigauge with envelope scale. This measurement should be taken at the widest part.

Service Limit	0.080 mm
---------------	----------

- If oil clearance is exceeded service limit, select the specified bearings from the following table.
- Check the corresponding conrod I.D. code number ①, "1" or "2".
- Check the corresponding crank pin O.D. code number ②, "1", "2" or "3".
- The crank pin O.D. code number is on the inside of No. 1 crank web.

#### Bearing selection table

		Crank pin O.D. code		
		1	2	3
Conrod I.D. code	1	Green	Black	Brown
	2	Black	Brown	Yellow

#### Oil clearance

Standard	0.024 – 0.048 mm
----------	------------------

#### Connecting rod I.D. specification

Code	I.D. Specification
1	33.000 – 33.008 mm
2	33.008 – 33.016 mm

#### Crank pin O.D. specification

Code	O.D. Specification
1	29.992 – 30.000 mm
2	29.984 – 29.992 mm
3	29.976 – 29.984 mm

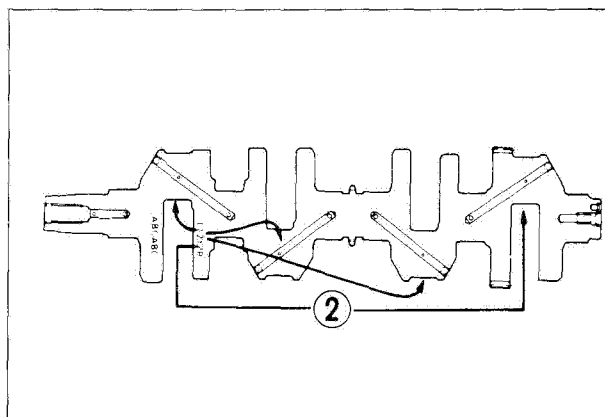
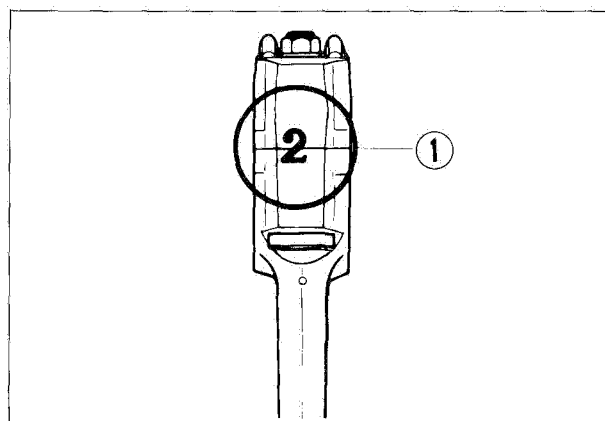
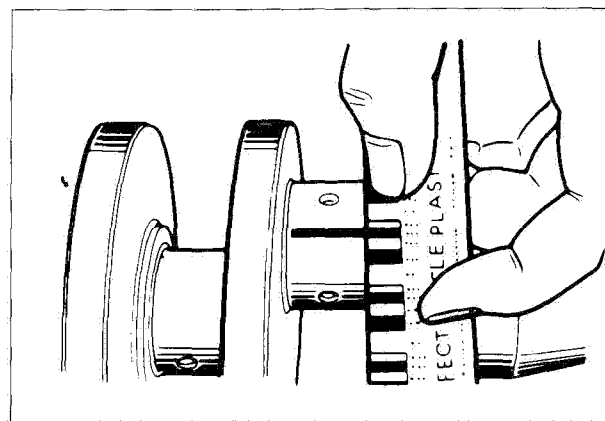

#### CAUTION:

Bearing should be replace as a set.

**Bearing thickness**

Color (Part No.)	Thickness
Green (12164-04A01-0A0)	1.484 – 1.488 mm
Black (12164-04A01-0B0)	1.488 – 1.492 mm
Brown (12164-04A01-0C0)	1.492 – 1.496 mm
Yellow (12164-04A01-0D0)	1.496 – 1.500 mm

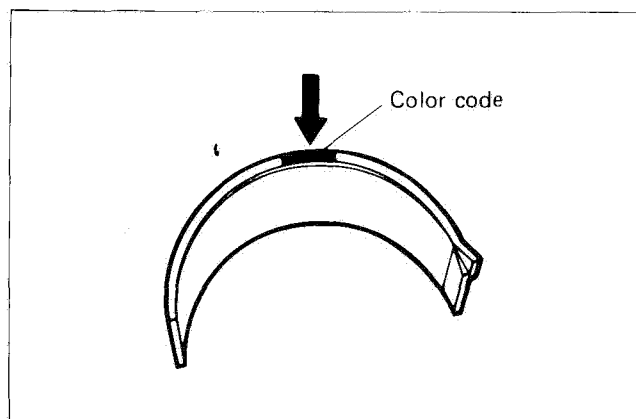
**BEARING ASSEMBLY**

- When fitting the bearings to the bearing cap and connecting rod, be sure to fix the stopper part ① first and press the other end.

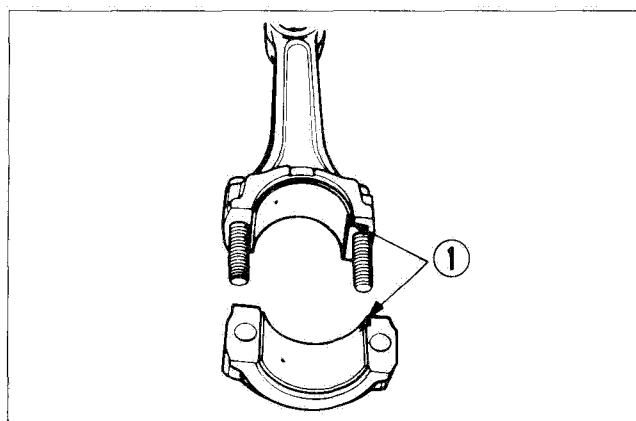

- Check the connecting rod oil hole ① to align with the bearing oil hole ②.

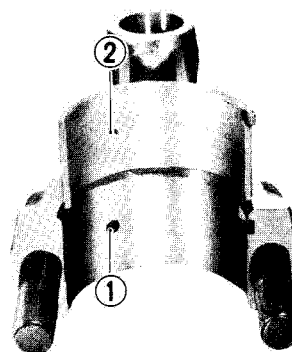

- Apply engine oil or SUZUKI Moly Paste to the crank pin and bearing surface.

99000-25140	SUZUKI Moly Paste
-------------	-------------------

**NOTE:**

Never try to remove or loosen the connecting rod big end stud, otherwise, it will displace the stud and will not fit the bearing cap properly.

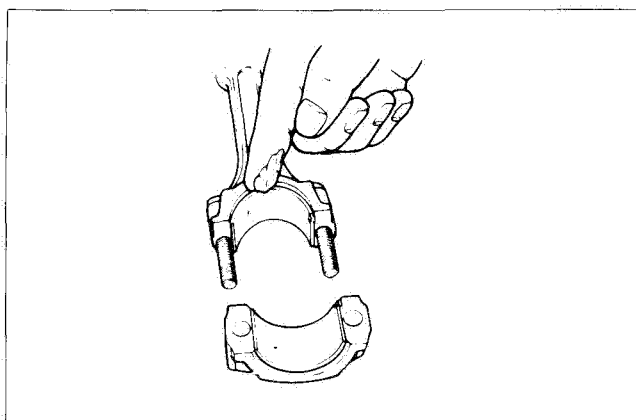



- When mounting connecting rod on the crank shaft, make sure that oil hole (1) of the connecting rod faces rearward.
- Tighten the connecting rod fitting nuts with specified torque.

Tightening torque	23 – 27 N·m (2.3 – 2.7 kg·m)
-------------------	---------------------------------

- Check the connecting rod for smooth turning.

### CRANKCASE-CRANKSHAFT BEARING SELECTION

- Inspect each bearing of upper and lower crank cases for any damage.

- Place plastigauge on each crankshaft journal in the usual manner.

#### NOTE:

Do not place the plastigauge on the oil hole, and do not rotate the shaft when plastigauge is in place.

- Mate the lower crankcase with the upper crankcase, and tighten the crankcase securing bolts with specified torque value in the indicated order.

	Initial Tightening	Final Tightening
8-mm bolt	13 N·m (1.3 kg·m)	20 – 24 N·m (2.0 – 2.4 kg·m)

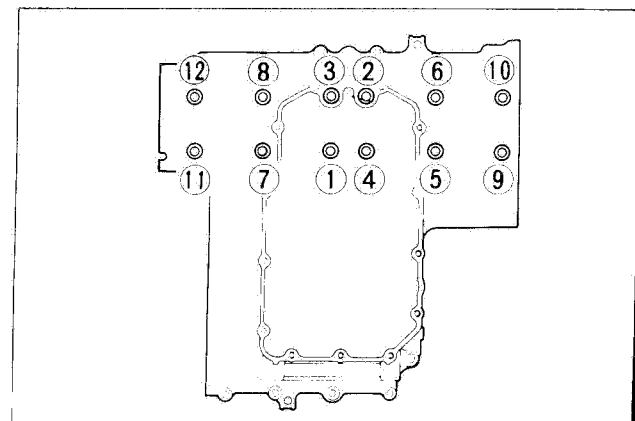
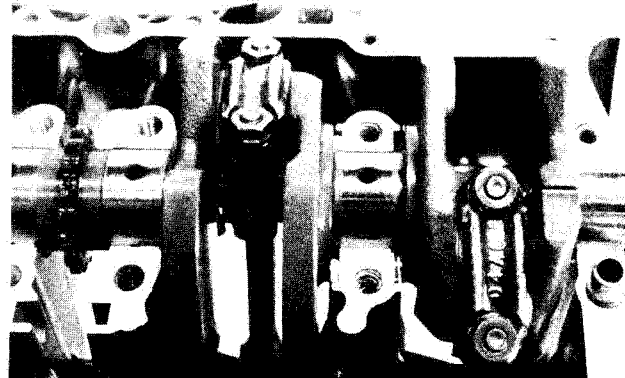
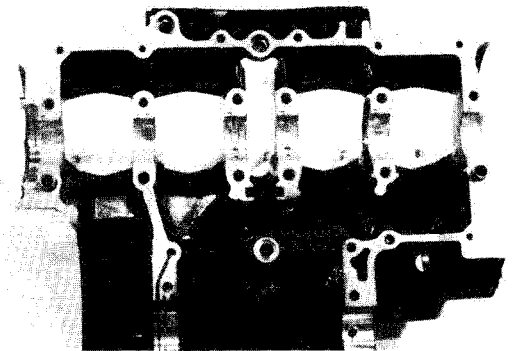
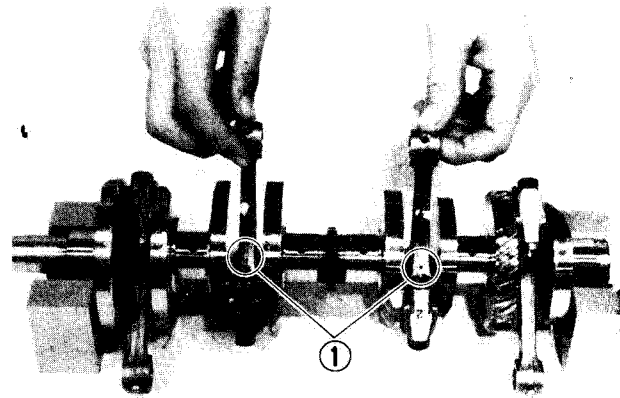

- Remove the lower crankcase, and measure the width of compressed plastigauge in the usual manner.

Crankshaft journal Oil clearance	0.020 – 0.044 mm
----------------------------------	------------------

Service Limit	0.080 mm
---------------	----------

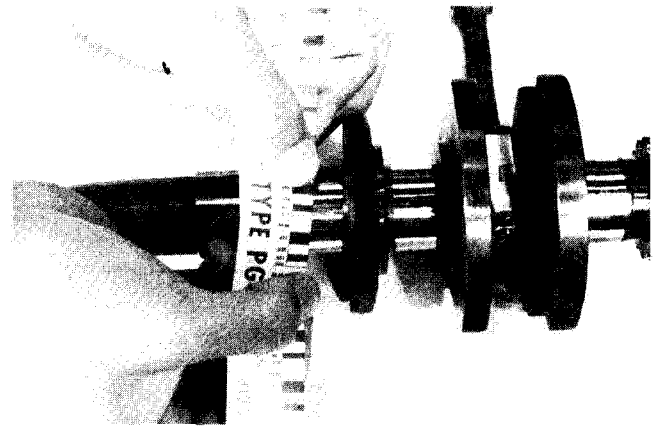

- If the width at the widest part exceeds the limit, replace the set of bearing with new ones by referring to the selection table.
- Check the corresponding crankcase journal I.D. code number ① "A" or "B" which are stamped on the rear of upper crankcase.

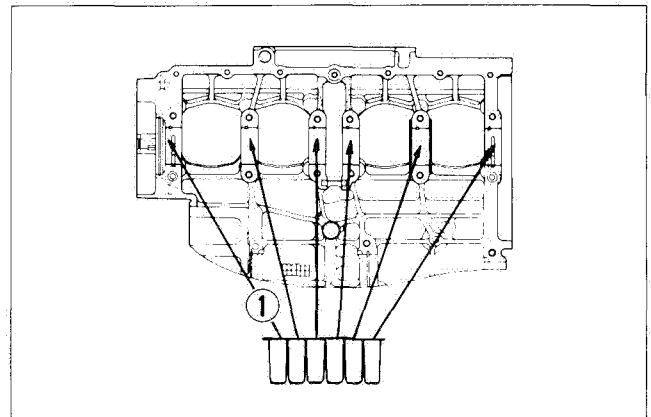

- Check the corresponding crankshaft journal O.D. code number ② "A", "B" or "C", printed on the left web of No. 1 cylinder.

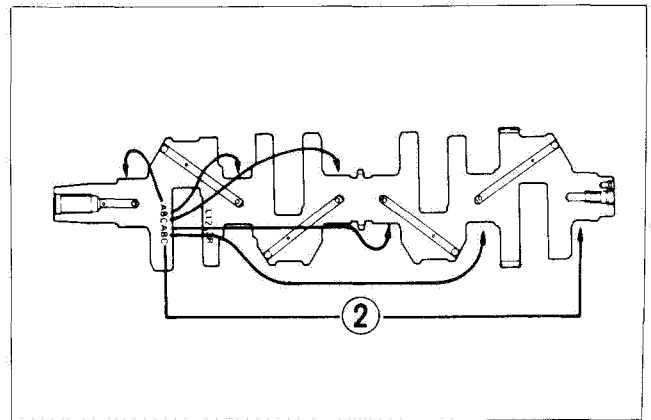

**Bearing selection table**

		Crankshaft O.D. code		
		A	B	C
Crankcase I.D. code	A	Green	Black	Brown
	B	Black	Brown	Yellow

**Crankcase I.D. specification**

Code	I.D. specification
A	35.000 – 35.008 mm
B	35.008 – 35.016 mm

**Crankshaft journal O.D. specification**

Code	O.D. specification
A	31.992 – 32.000 mm
B	31.984 – 31.992 mm
C	31.976 – 31.984 mm

**Bearing thickness specification (journal bearing with oil groove)**

Color (Part number)	Specification
Green (12229-43400-0A0)	1.486 – 1.490 mm
Black (12229-43400-0B0)	1.490 – 1.494 mm
Brown (12229-43400-0C0)	1.494 – 1.498 mm
Yellow (12229-43400-0D0)	1.498 – 1.502 mm

**Option Bearing**

Red (12229-43400-0E0)	1.502 – 1.506
Blue (12229-43400-0F0)	1.506 – 1.510
Pink (12229-43400-0G0)	1.510 – 1.514

**NOTE:**

\* Non-Grooved bearings have the same specification as the Grooved bearings with oil holes.

These parts numbers are shown as follows.  
12229-43410-XXX.

\* Bearing locations are shown in the illustration. If the bearings ① fit to the lower crankcase, it causes burnt crankshaft journal bearings and conrod bearings.

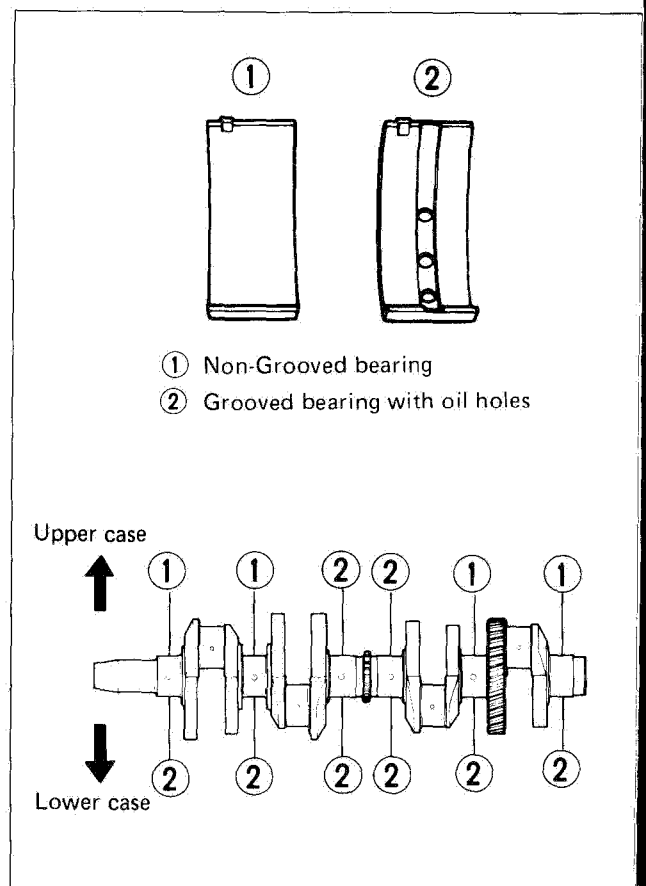
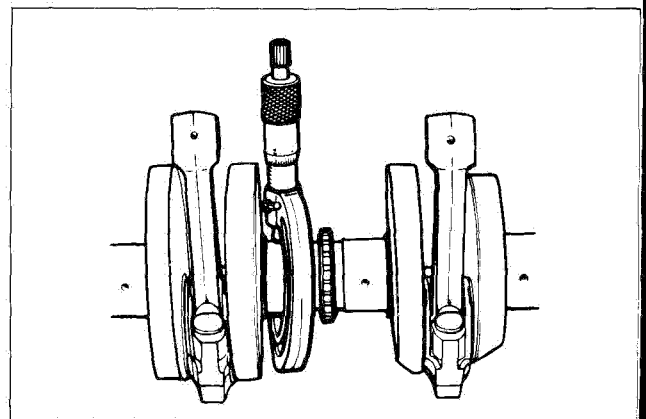
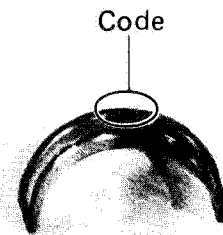

## CRANKSHAFT THRUST CLEARANCE

- With the crankshaft, right-side thrust bearing and left-side thrust bearing inserted in the upper crankcase, use a thickness gauge to measure the thrust clearance on the left side.

### NOTE:

Push the crankshaft to the generator side, so that there is no clearance on the right-side thrust bearing.

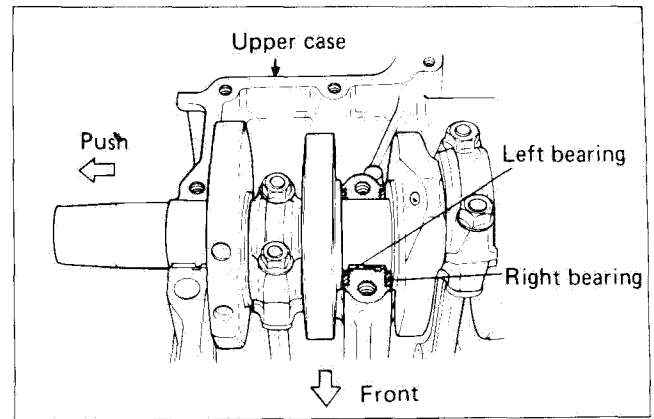

### Thrust clearance

Standard	0.045 – 0.100 mm
----------	------------------

If the thrust clearance exceeds the standard range, adjust the thrust clearance by the following procedures:

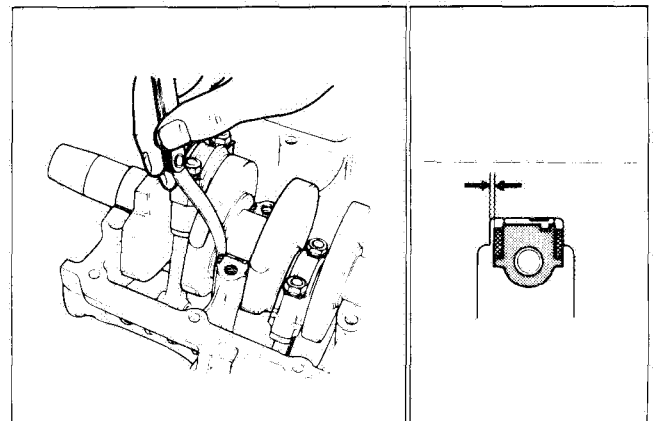

- Remove the right-side thrust bearing, and measure its thickness with a micrometer. If the thickness of the right-side thrust bearing is below standard, replace with a new bearing and once again perform the thrust clearance measurement listed above, checking to make sure it is within standard.

### Right-side thrust bearing thickness

Standard	2.425 – 2.450 mm
----------	------------------

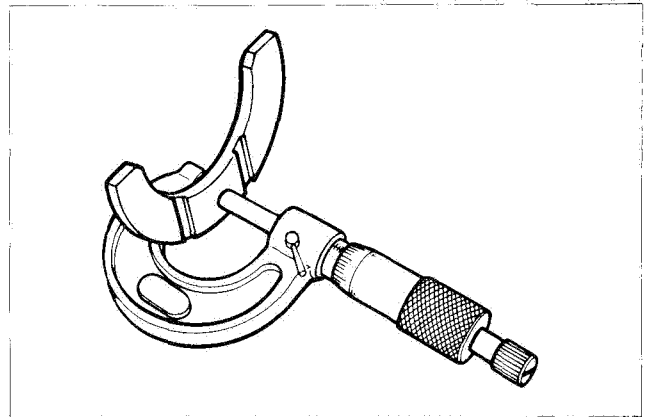

- If the right-side thrust bearing is within the standard range, reinsert the right-side thrust bearing, and remove the left-side thrust bearing.
- As shown in the illustration, use a thickness gauge to measure the clearance before inserting of the left-side thrust bearing, and select a left-side thrust bearing from the selection table.

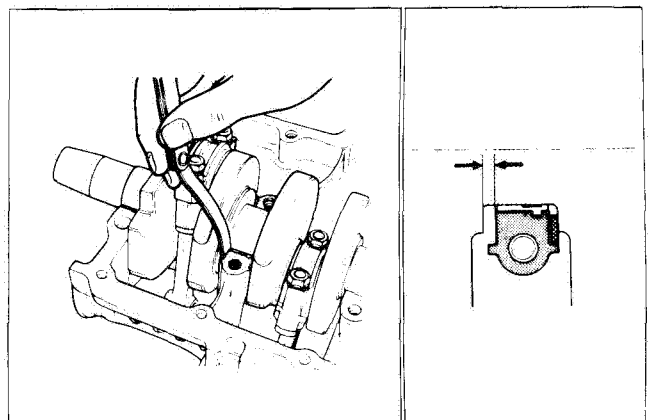

Thrust bearing selection table

Clearance before inserting of left-side thrust bearing	Color (Part No.)	Thrust bearing thickness	Standard thrust clearance
2.420 – 2.445 mm	Red (12228-43411)	2.350 – 2.375 mm	0.045 – 0.095 mm
2.445 – 2.470 mm	Black (12228-43412)	2.375 – 2.400 mm	
2.470 – 2.495 mm	Blue (12228-43413)	2.400 – 2.425 mm	
2.495 – 2.520 mm	Green (12228-43414)	2.425 – 2.450 mm	
2.520 – 2.545 mm	Yellow (12228-43415)	2.450 – 2.475 mm	
2.545 – 2.575 mm	White (12228-43416)	2.475 – 2.500 mm	0.045 – 0.100 mm

- After selecting a left-side thrust bearing, insert it and again perform the thrust clearance measurement to make sure it falls within the standard range.

**NOTE:**

Always install the Green bearing (12228-43414) for right-side.

**NOTE:**

Right-side thrust bearing has the same specification as the green of left-side thrust bearing.

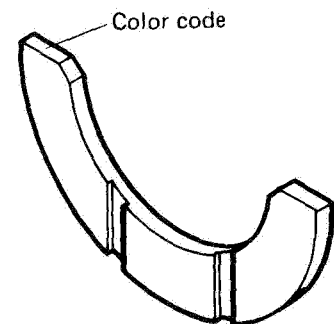
**CRANKSHAFT RUNOUT**

Support the crankshaft with "V" blocks as shown, with the two end journal resting on the blocks. Set up the dial gauge, as shown, and rotate the crankshaft slowly to read the runout. Replace the crankshaft if the runout is greater than the limit.

**Crankshaft runout**

Service Limit	0.05 mm
---------------	---------

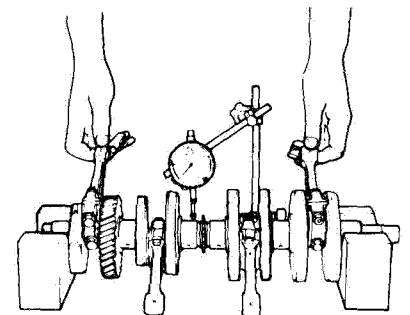

## CLUTCH DRIVE PLATES AND DRIVEN PLATES

Clutch plates in service remain in oily condition as if they were lubricated with oil. Because of this condition, both drive and driven plates are subject to little wearing action and therefore last much longer. Their life depends largely on the quality of oil used in the clutch and also on the way the clutch is operated.

These plates are expendable: they are meant to be replaced when found worn down or distorted to the respective limit: use a caliper to check thickness and a thickness gauge and surface plate to check distortion.

09900-20102	Vernier calipers
09900-20803	Thickness gauge

Unit: mm

Service Limit	Drive plate	Driven plate
Thickness	2.60	—
Distortion	—	0.1
Claw width	11.0	—

## CLUTCH SPRING FREE LENGTH

Measure the free length of each coil spring with vernier calipers, and compare the elastic strength of each with the specified limit. Replace all the springs if any spring is not within the limit.

### Clutch spring free length

Service Limit	31.0 mm
---------------	---------

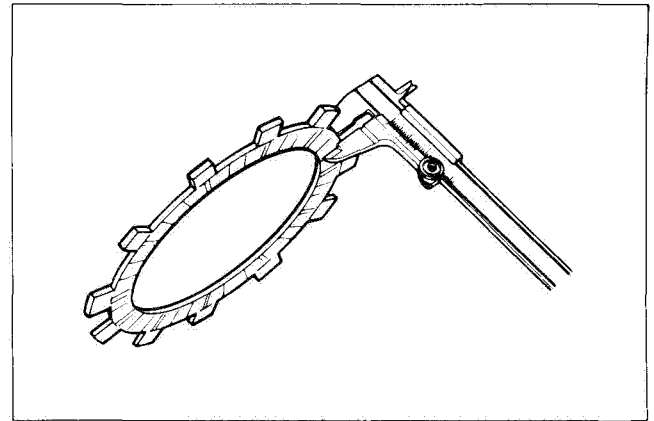

Checking thickness

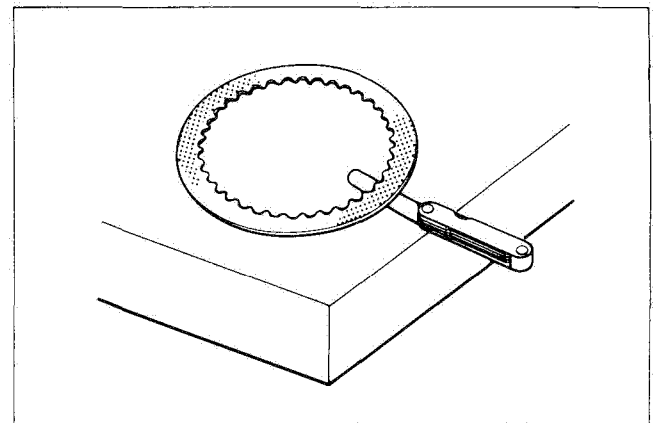

Checking distortion

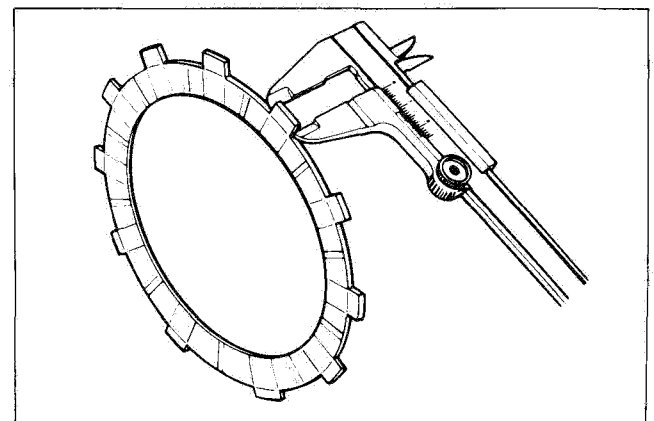

Checking claw width

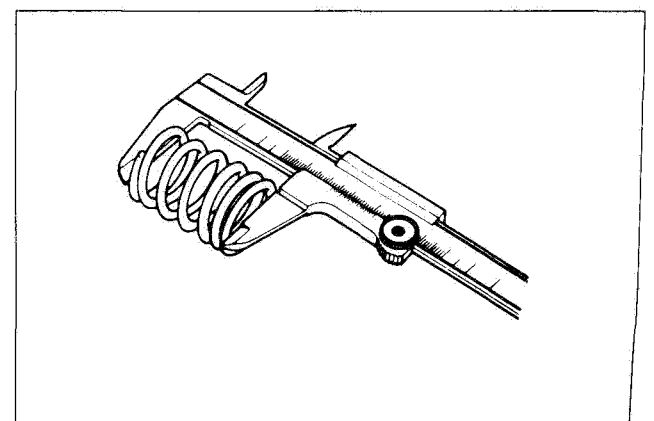

## CLUTCH BEARINGS

Inspect clutch push piece bearing for any abnormality, particularly cracks, upon removal from the clutch, to decide whether it can be reused or should be replaced.

Smooth engagement and disengagement of the clutch depends much on the condition of this bearing.



## STARTER CLUTCH REMOVAL

- Remove roller ①, spring ②, and push piece ③ from starter clutch.

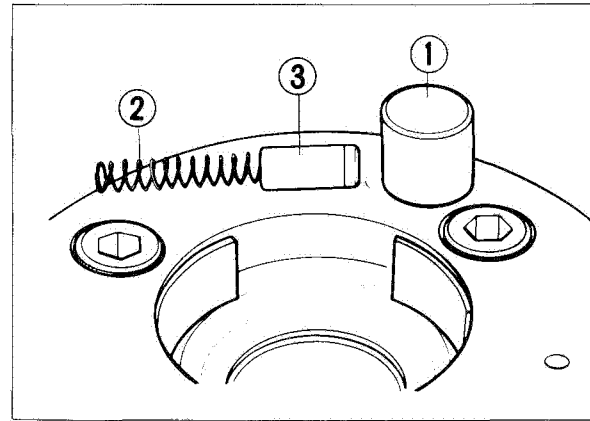

- While holding the rotor with a special tool taking care not to damage it and separate starter clutch from the rotor using the T type hexagon wrench ④.

09914-25811	"T" type hexagon wrench (6 mm)
09930-44911	Rotor holder

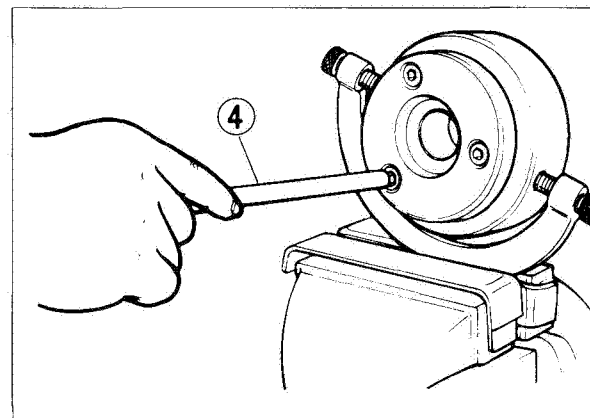

**ASSEMBLY**

- Apply THREAD LOCK "1342" (99000-32050) to the stator set screws and its lead wire guide screws.

**NOTE:**

Wipe off oil and grease on screw completely, and then apply the screw lock.

- Mount the lead wire clamp as shown in the photo.
- Locate the shim ① to the proper position.

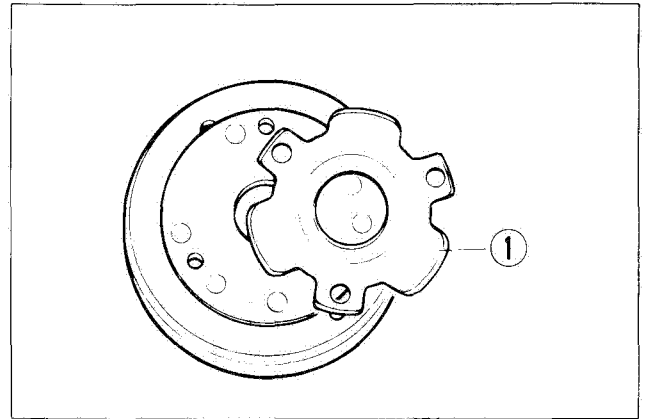
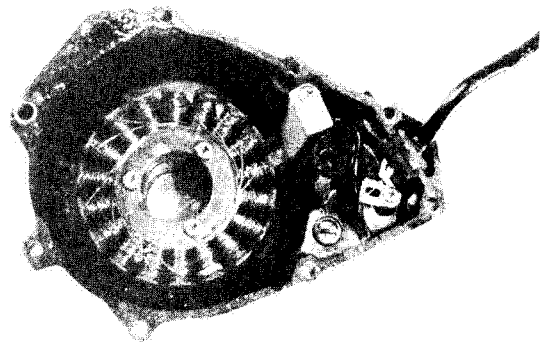

- Apply THREAD LOCK SUPER "1303" to allen bolts and tighten them with specified torque.

99000-32030	Thread lock super "1303"
-------------	--------------------------

09914-25811	T-type hexagon wrench (6 mm)
-------------	------------------------------

Tightening torque	23 – 28 N·m (2.3 – 2.8 kg·m)
-------------------	---------------------------------

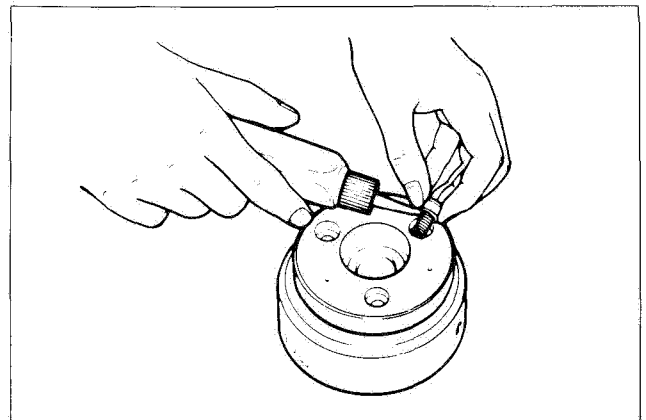
**OIL PUMP****WARNING:**

Oil pump case securing screws are applied with SUZUKI THREAD LOCK SUPER "1303". If attempt to overhaul the oil pump assembly, screw may be damaged. As a replacement, only the oil pump unit is available.

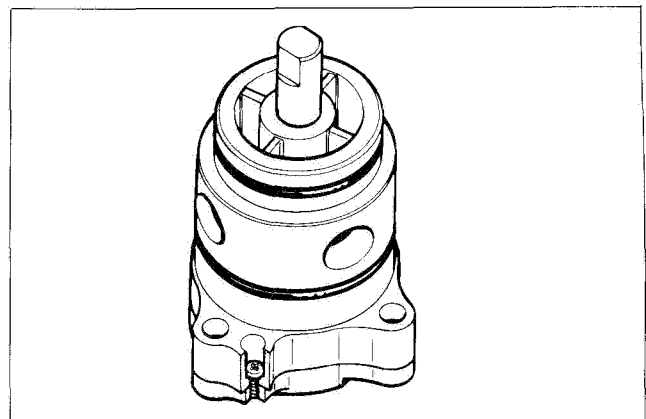

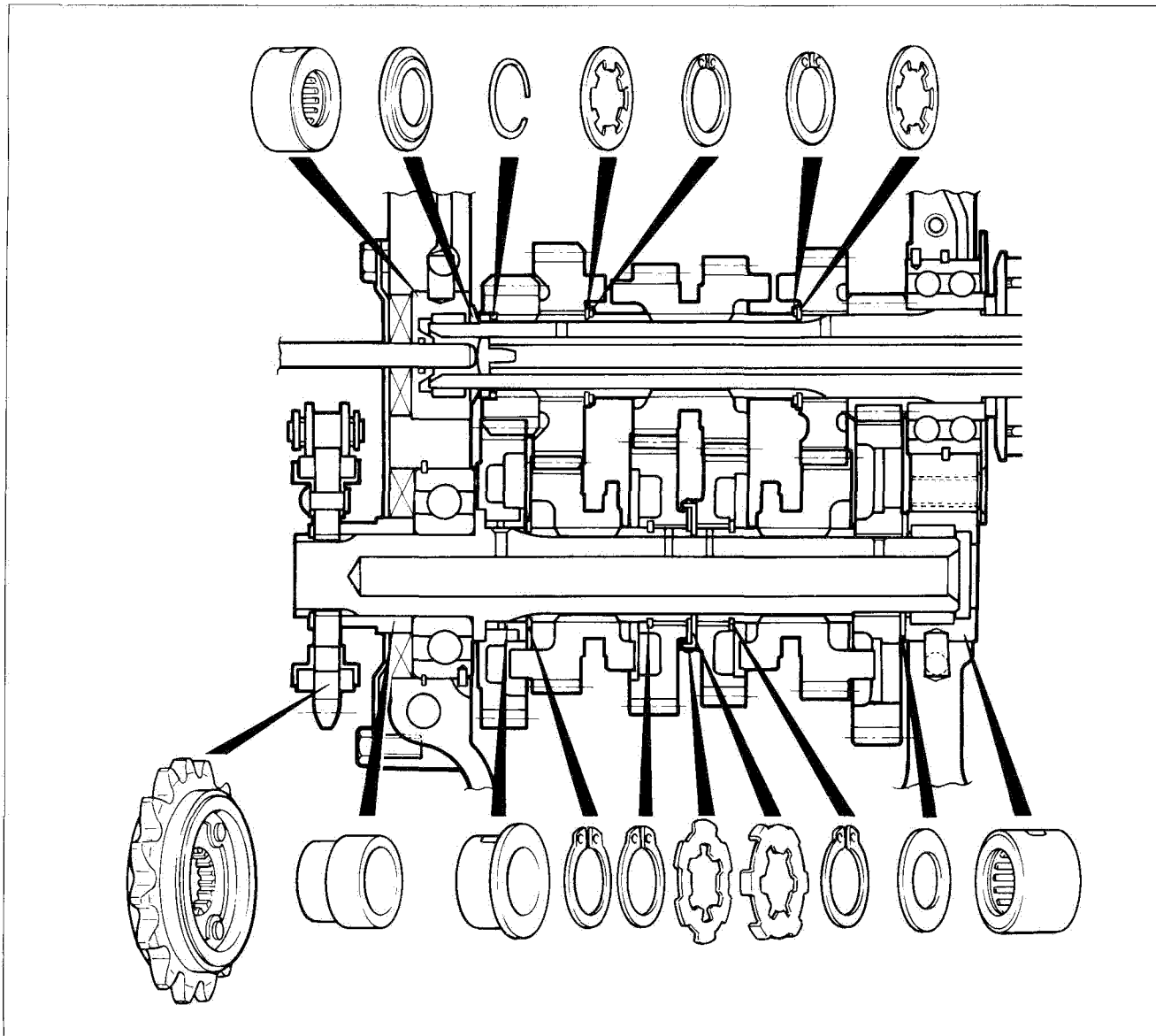

## TRANSMISSION GEARS AND RELATED PARTS

**GEAR-SHIFTING FORK CLEARANCE**

Using a thickness gauge, check the shifting fork clearance in the groove of its gear.

This clearance for each of the three shifting forks plays an important role in the smoothness and positiveness of shifting action. Each fork has its prongs fitted into the annular groove provided in its gear. In operation, there is sliding contact between fork and gear and, when a shifting action is initiated, the fork pushes the gear axially. Too much a clearance is, therefore, liable to cause the meshed gears to slip apart.

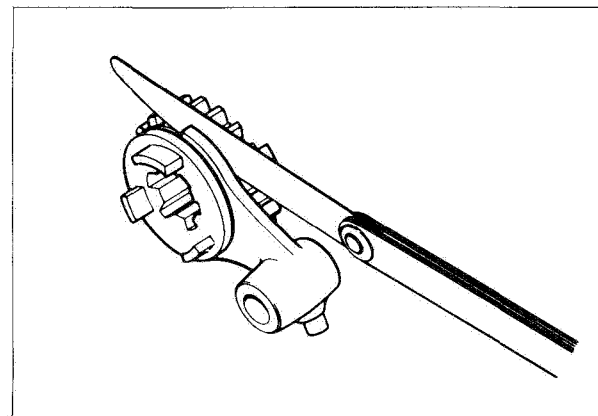

If the clearance checked is noted to exceed the limit specified, replace the fork or its gear, or both.

09900-20803	Thickness gauge
-------------	-----------------

#### Shift fork — groove clearance

		Service Limit
No. 1	for 5th driven gear	0.50 mm
No. 2	for 6th driven gear	
No. 3	for 3rd/4th drive gears	

#### Shift fork groove width

Standard	5.50 — 5.60 mm
----------	----------------

#### Shift fork thickness

Standard	5.30 — 5.40 mm
----------	----------------

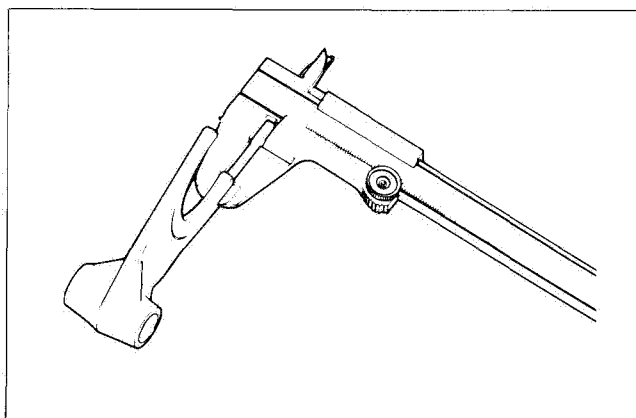

### COUNTERSHAFT DISASSEMBLY

- Remove the bearing and oil seal ①.
- Remove the 6th drive gear circlip ② from the groove and slide circlip toward the 3rd/4th drive gears ③.

09900-06104	Snapping pliers
-------------	-----------------

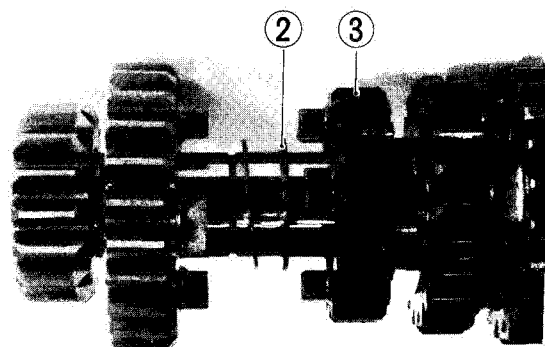
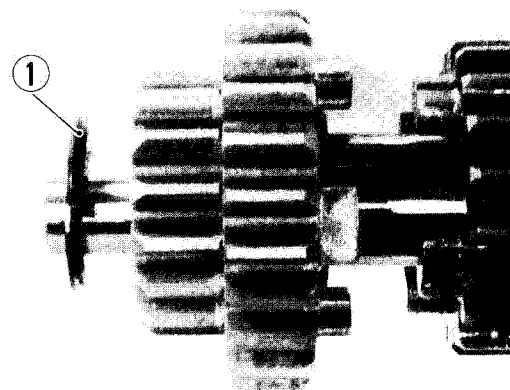

- Slide the 6th and 2nd drive gears toward the 3rd/4th drive gears and remove the 2nd drive gear circlip ④.

#### NOTE:

These circlips should be replaced with new ones.

- Remove the 3rd/4th drive gear.

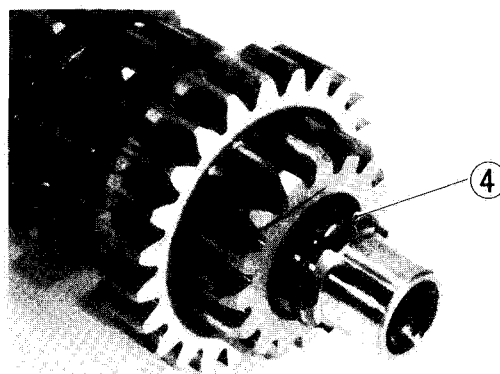

- Remove the 5th drive gear circlip and 5th drive gear.

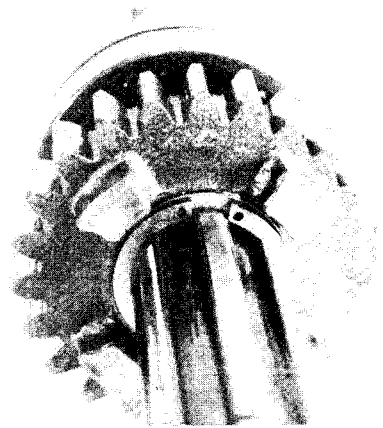

### COUNTERSHAFT REASSEMBLY

- Before installing the gears, coat lightly moly paste to the countershaft.

99000-25140	SUZUKI Moly Paste
-------------	-------------------

- When mounting the circlip, pay attention to the direction of the circlip. Fit it to the side where the thrust is as shown in the figure.

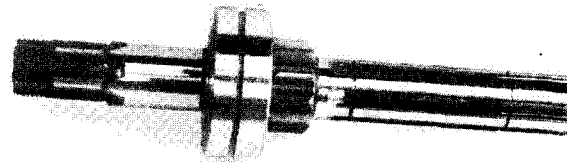

#### NOTE:

Always use new circlip.

#### CAUTION:

Never reuse a circlip. After a circlip has been removed from a shaft, it should be discarded and a new circlip must be installed.

When installing a new circlip, care must be taken not to expand the end gap larger than required to slip the circlip over the shaft.

After installing a circlip, always insure that it is completely seated in its groove and securely fitted.

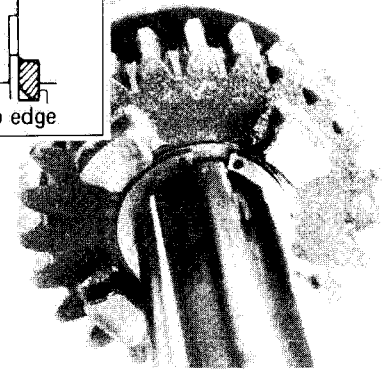
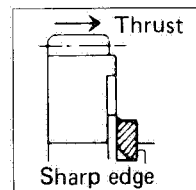

### DRIVESHAFT DISASSEMBLY

Each driven gear on the driveshaft is easily removed by using snapping pliers.

09900-06107	Snapping pliers
-------------	-----------------

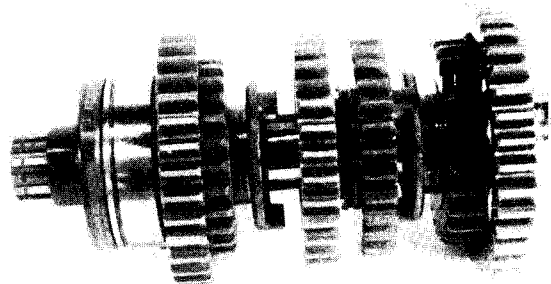

The order of disassembling is as follows;

- |                        |                   |
|------------------------|-------------------|
| ① Right end bearing    | ⑧ 3rd driven gear |
| ② Washer               | ⑨ Circlip         |
| ③ 1st driven gear      | ⑩ 6th driven gear |
| ④ 5th driven gear      | ⑪ Circlip         |
| ⑤ Circlip              | ⑫ Bushing         |
| ⑥ 4th driven gear      | ⑬ 2nd driven gear |
| ⑦ Pair of lock washers |                   |

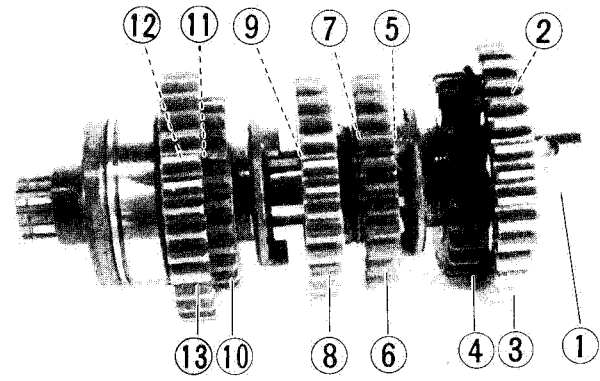

## DRIVESHAFT REASSEMBLY

- Install the 2nd driven gear bushing ①.

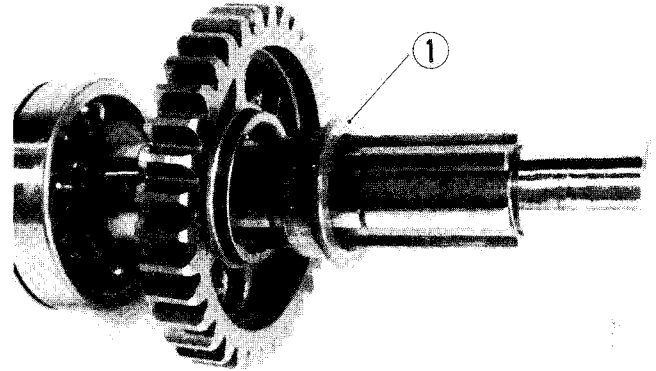

- After mounting the 3rd driven gear ②, install the washer ③ in the groove properly, then engage the washer ④ to the washer ③.

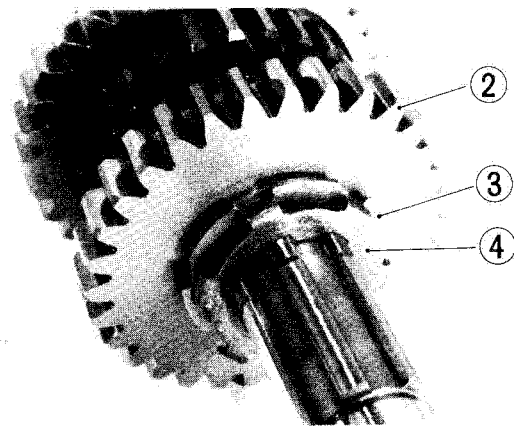

## ENGINE REASSEMBLY

This engine is reassembled by carrying out the steps of disassembly in the reversed order, but there are a number of steps which demand special descriptions or precautionary measures.

### NOTE:

Apply engine oil to each running and sliding part before reassembling.

- Refer to the following figure in regard to the correct positions and orientations of the forks when installing these parts.

- ① : Gearshift fork for 5th driven gear.
- ② : Gearshift fork for 3rd/4th drive gears.
- ③ : Gearshift fork for 6th driven gear.

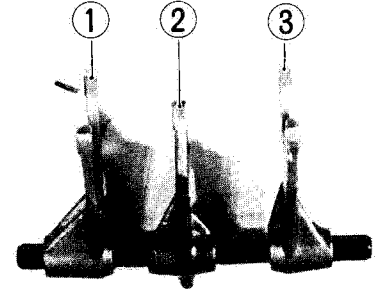

- Before driving in fork shaft stopper screw and washer ① and cam guide bolt ②, apply THREAD LOCK "1342" to their threads.

99000-32050	Thread lock "1342"
-------------	--------------------

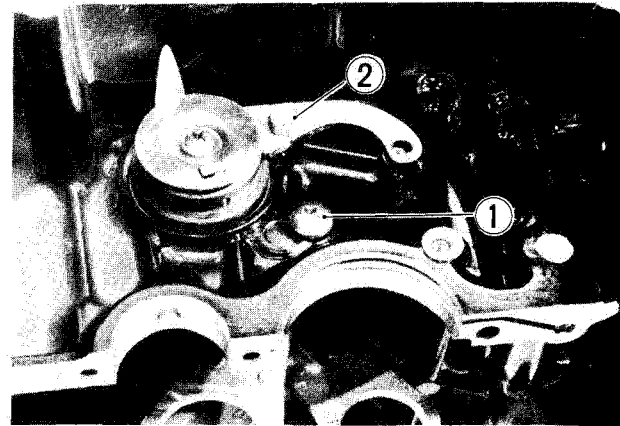

- Install the gearshifting cam with the dent for the neutral stopper directed downward, and meet the neutral stopper ③ with this dent ④.

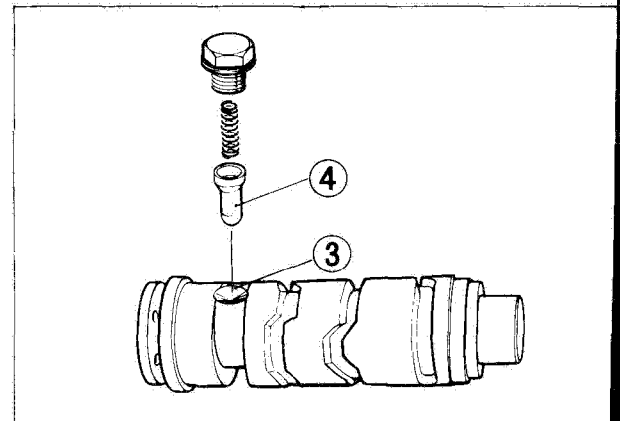

- Tighten the neutral stopper housing to the following torque value.

Tightening torque	18 – 28 N·m (1.8 – 2.8 kg·m)
-------------------	---------------------------------

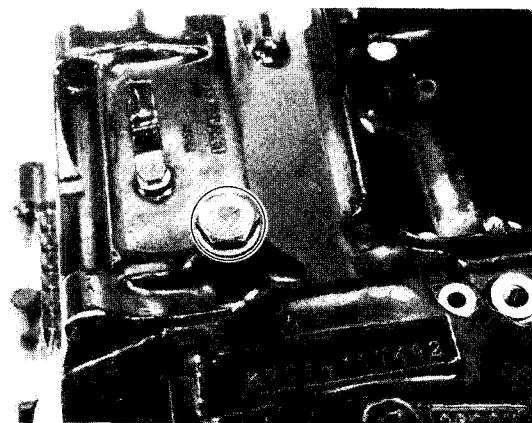

- Place cam chain guide ① properly, and fix two dampers ② so that the iron side faces to the chain guide pin (inside).

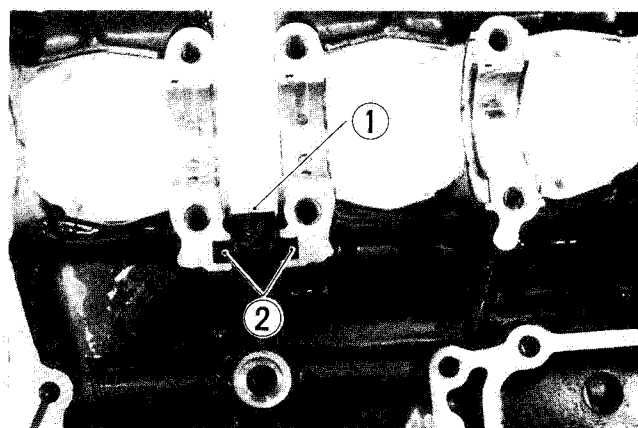
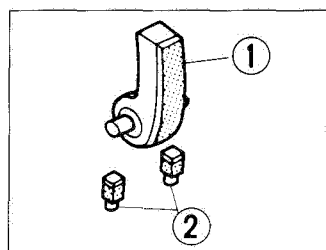

- Identify the two kinds of crankshaft journal bearings, one has an oil groove ③ and the other ④ has no oil groove on its surface. Grooved one should be fix to the lower crankcase and both side ① of chain cavity, and the other to the position ② of the upper crankcase as shown in the figure.

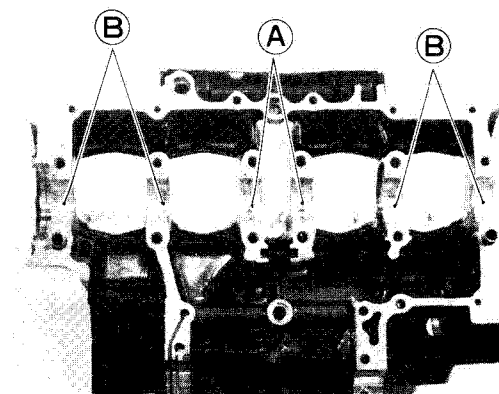

- Apply SUZUKI Moly Paste to each journal bearing lightly.

99000-25140	SUZUKI Moly Paste
-------------	-------------------

- When fitting the bearings to the crankcase, be sure to fix the stopper part ⑤ first and press the other end ⑥.

**CAUTION:**

Do not touch the bearing surfaces with your hands. Grasp by the edge of the bearing shell.

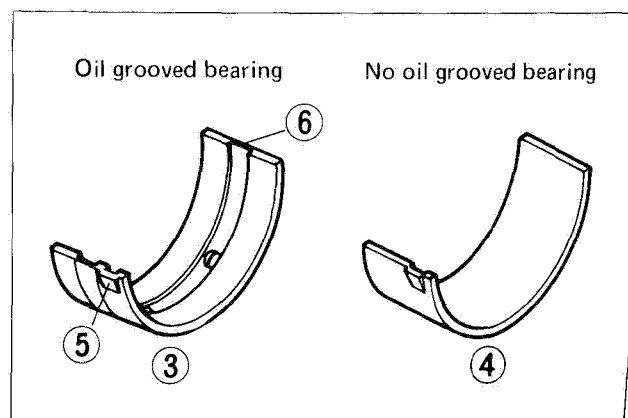

- Install the right and left-thrust bearings ① with the oil groove facing the crank web.
- Mount the crankshaft with cam drive chain to the upper crankcase.
- Apply SUZUKI super grease "A" to the lip of the crankshaft oil seal.

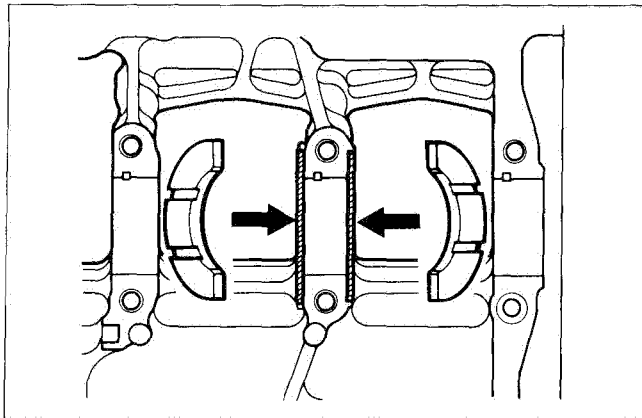

- Place two "C" rings ① and a knock pin ② and install drive and countershafts.

- Install the countershaft and driveshaft oil seals, positioning as shown.

**NOTE:**

- \* Install the O-ring ③.
- \* Check the two oil jets ④ for clogging.

- Clean the mating surfaces of the crankcases before matching the upper and lower ones.
- Apply SUZUKI BOND No. 1207B to the mating surface of the lower crankcase in the following procedure.

99000-31140	SUZUKI Bond No. 1207B
-------------	-----------------------

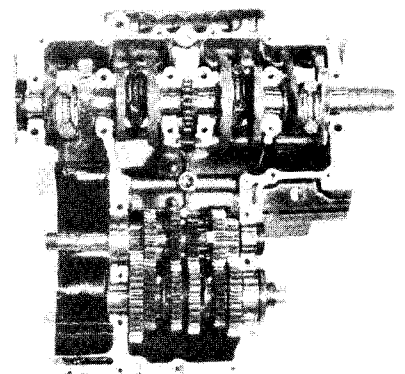
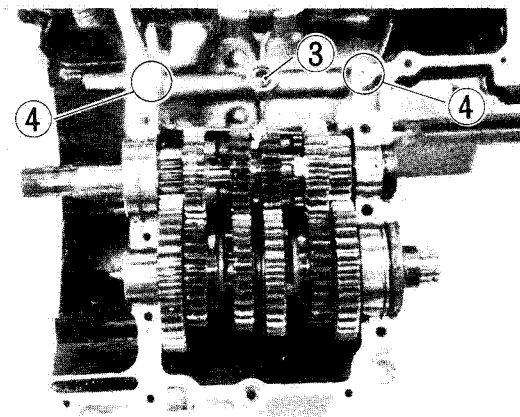
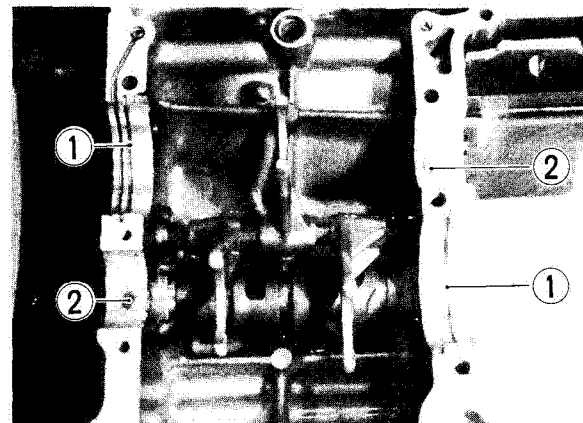
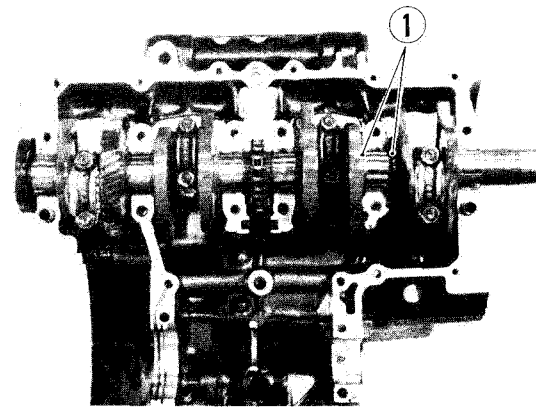

**NOTE:**

Use of SUZUKI BOND No. 1207B is as follows:

- \* Make surfaces free from moisture, oil, dust and other foreign materials.
- \* Spread on surfaces thinly to form an even layer, and assemble the crankcases within few minutes.
- \* Take extreme care not to apply any bond No. 1207B to the bearing surfaces.
- \* Apply to distorted surface as it forms a comparatively thick film.

- Locate the two allen bolts at position ① and ten 8 mm bolts.

**NOTE:**

- \* Do not forget to tighten the 4-mm allen bolt ②.
- \* Install the gasket to the positions ⑨ and ⑪.

- When securing the lower crankcase, tighten the 8 mm bolts and the 6 mm bolts in the ascending order of numbers assigned to these bolts, tightening each bolt a little at a time to equalize the pressure. Tighten all the securing bolts to the specified torque values.

09914-25811	6 mm T-type hexagon
-------------	---------------------

Tightening torque	Initial tightening		Final tightening	
	N·m	kg·m	N·m	kg·m
6 mm bolt	6	0.6	13	13
8 mm bolt	13	1.3	24	2.4

- Install the two O-rings ① and install the oil guide.
- Install the oil sump filter to face the oil inlet to the front.
- Apply thread lock "1342" to the three screws.

99000-32050	Thread Lock "1342"
-------------	--------------------

- Seat the guide and tighten the oil pressure regulator ② with specified torque.

Tightening torque	25 – 30 N·m (2.5 – 3.0 kg·m)
-------------------	---------------------------------

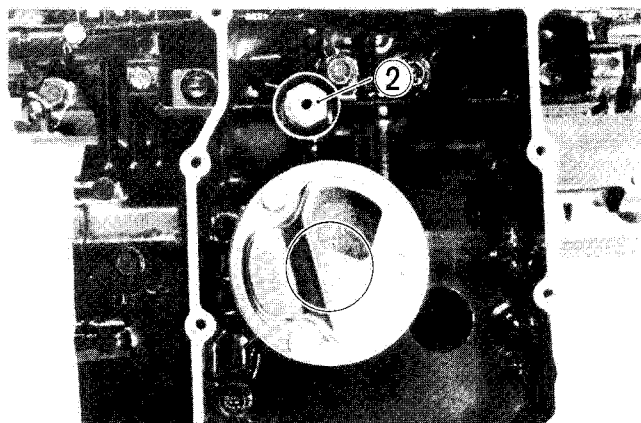
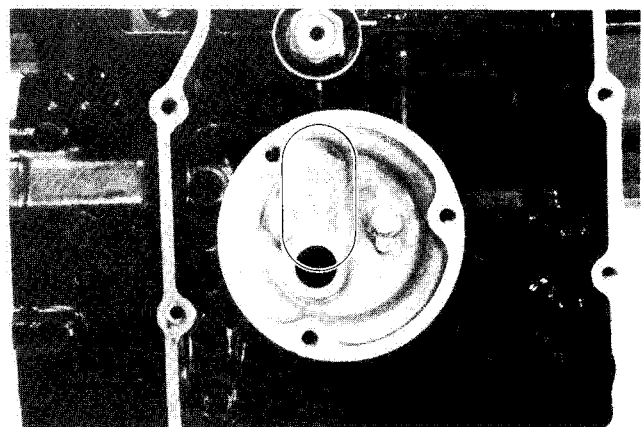
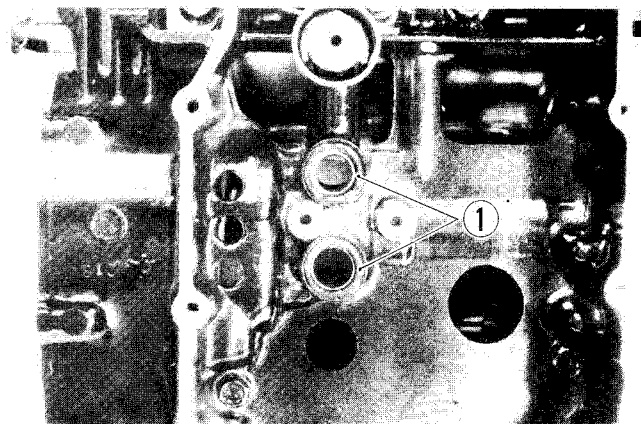
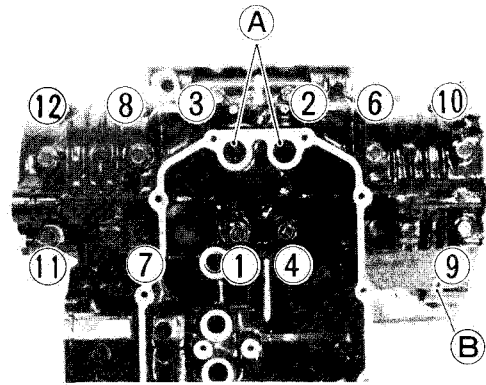



- Locate a new gasket and oil pan, and tighten 6 mm bolts with specified torque.

Tightening torque	8 – 13 N·m (0.8 – 1.3 kg-m)
-------------------	--------------------------------

**NOTE:**

Install the five clamps **A** for signal generator lead wire and two clamps **B** for oil level switch.

**C** : Clamp + Engine ground lead wire

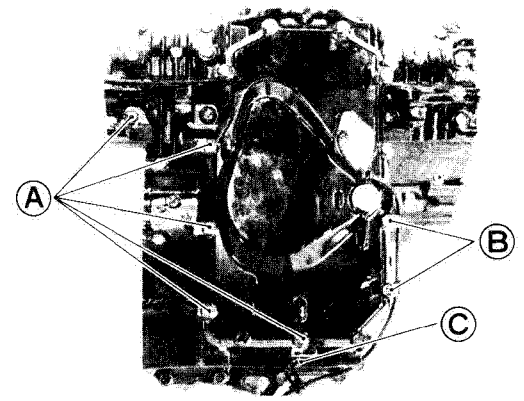

- Install the engine ground wire **C**, and crankcase securing bolts **1** and **2**.

Tightening torque	8 – 12 N·m (0.8 – 1.2 kg-m)
-------------------	--------------------------------

**NOTE:**

Install copper gasket to the bolts **1**.

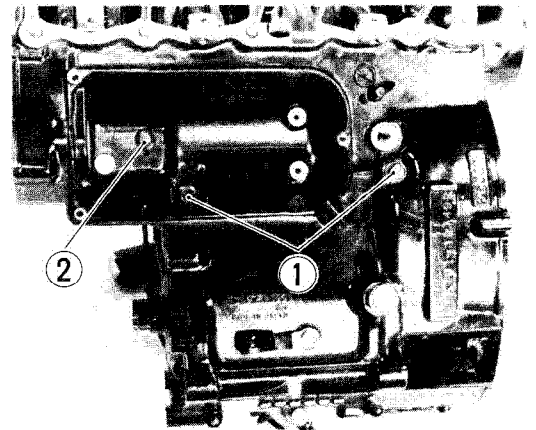

- Install the gear position indicator switch.

**NOTE:**

When installing gear position indicator switch, be sure to locate spring, switch contact, and O-ring.

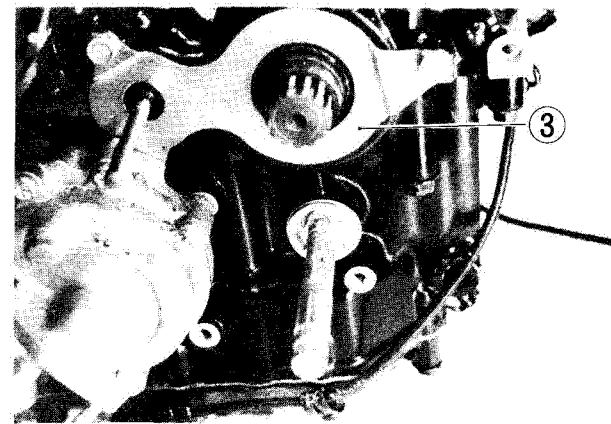

- Install the driveshaft oil seal holder **3** and positively bend the lock portion of the holder.

- Install the water pump to the crankcase.

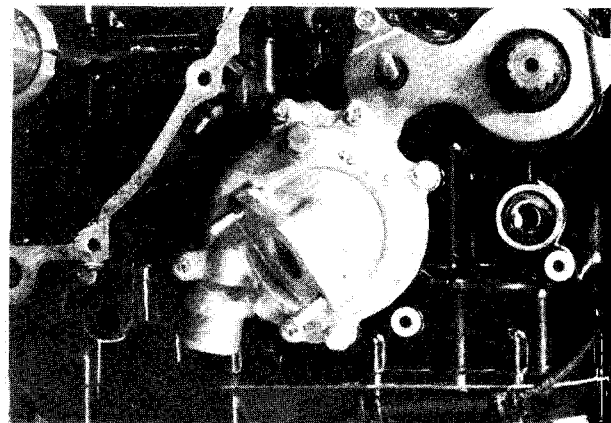

- Degrease the tapered portion of the rotor and also the crankshaft. Use nonflammable cleaning solvent to wipe off the oily or greasy matter to make these surfaces completely dry.
- After mounting the rotor, secure the rotor by tightening the center bolt to the specified torque value.

Tightening torque	140 – 160 N·m (14.0 – 16.0 kg-m)
-------------------	-------------------------------------

09930-44911	Rotor holder
-------------	--------------

99000-32100	Thread Lock Super "1305"
-------------	--------------------------

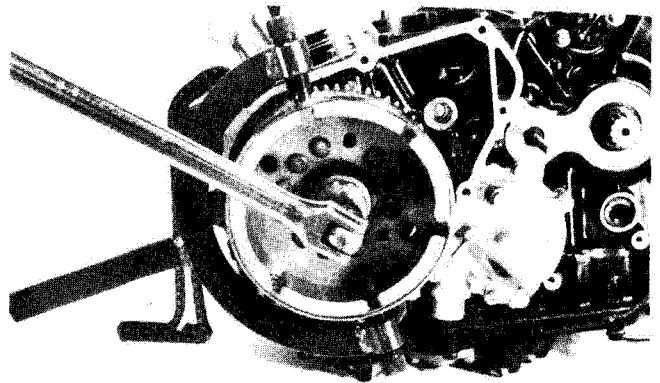
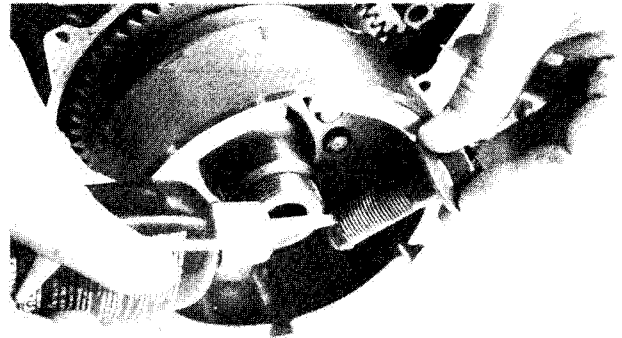

- Mount the starter motor, and route the lead wire properly.

99000-32050	Thread Lock "1342"
-------------	--------------------

- Install the starter idle gear and its shaft.
- Coat SUZUKI Bond No. 1207B lightly to the portion around mating surface between upper and lower crankcases as shown.

99000-31140	SUZUKI Bond No. 1207B
-------------	-----------------------

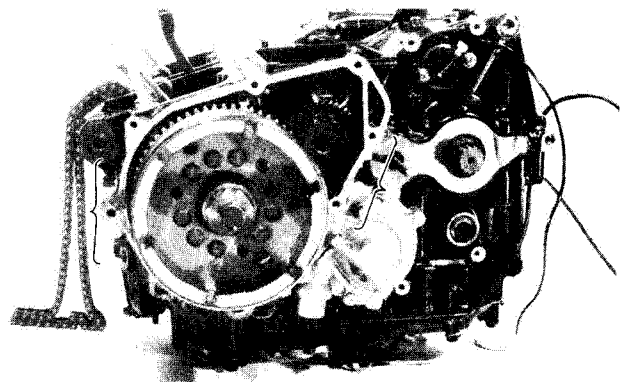

- Pass the generator stator lead wire through gasket and upper crankcase. Route its lead wire properly.

**NOTE:**

Always use new gasket, and install a positioning pin.

- Tighten the generator cover bolts securely.

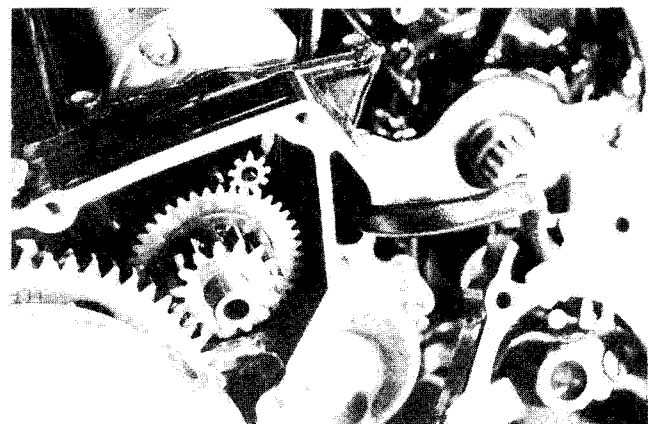

- Install the countershaft bearing retainer with two (16 mm length) screws.

99000-32050

Thread Lock "1342"

- Install the gearshift shaft and fix washer and clip to the gearshift shaft.

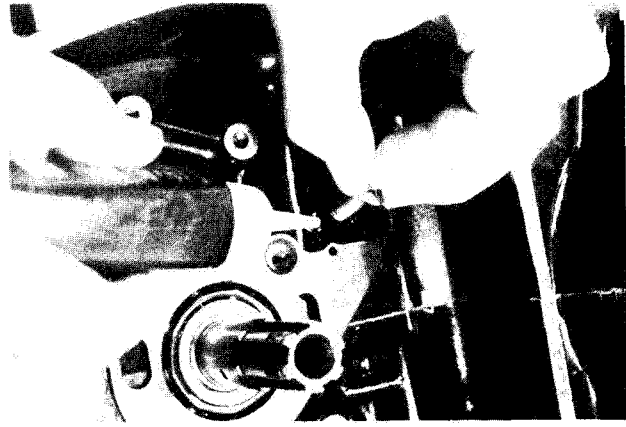

- Install the cam stopper with bolt.

99000-32050

Thread lock "1342"

**NOTE:**

After tightening the cam stopper bolt, move the stopper back and forth with fingers to be sure that its movement is normal.

- Bring the gear shifting cam to "NEUTRAL" position.
- Insert the neutral cam pin (half end circle pin) ① into the closest pin hole to cam stopper ②.
- Install the pin retainer ③ in such a way that the recess ④ of pin retainer will admit the semi-circle end of pin ①.
- Tighten the pin retainer securing screw with applying thread lock super "1303".

99000-32030

Thread lock supper "1303"

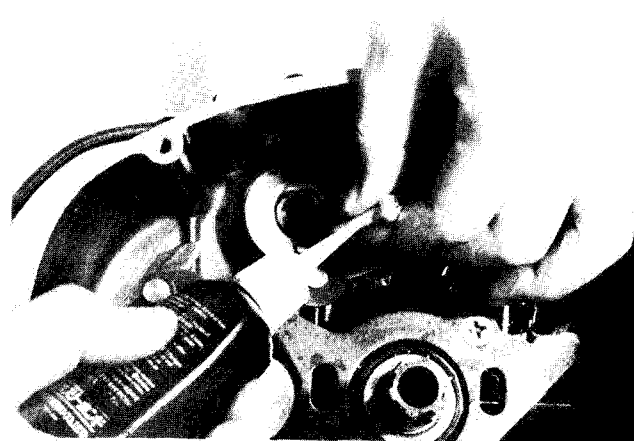
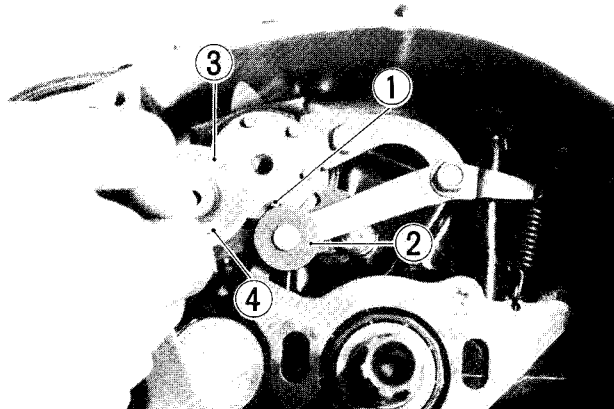
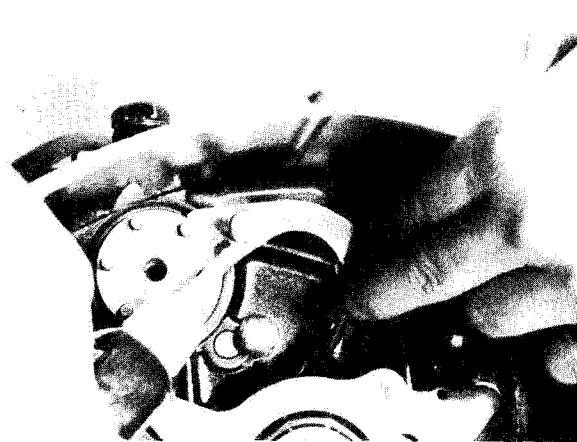
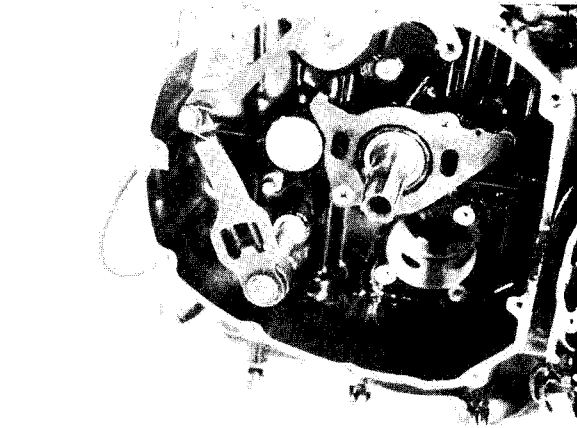

- Put a grease on the end piece ① not to drop it in the engine.
- Install new O-rings to the oil pump and install the oil pump to the crankcase.

Oil pump tightening torque	8–12 N·m (0.8 – 1.2 kg·m)
----------------------------	------------------------------

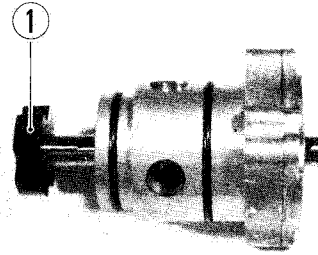

- Install the washer ②, drive pin ③ and driven gear ④ by using snapping pliers.
- Install the two washers ⑤ and ⑥ on the countershaft.
- Install the oil pump drive gear to the primary driven gear so that the protrusion side ⑦ of the oil pump drive gear faces the primary driven gear side.
- Install the washers to the countershaft in the order of the following illustration.

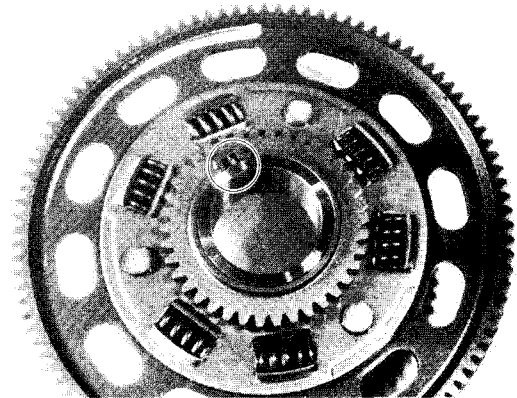
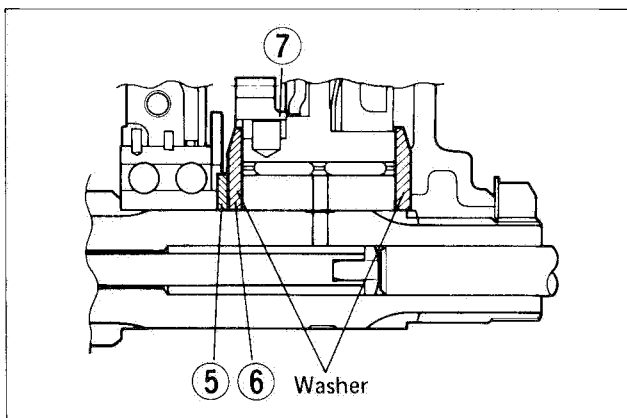
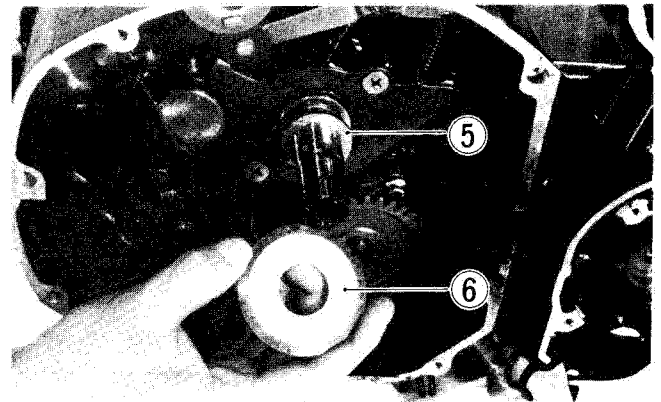
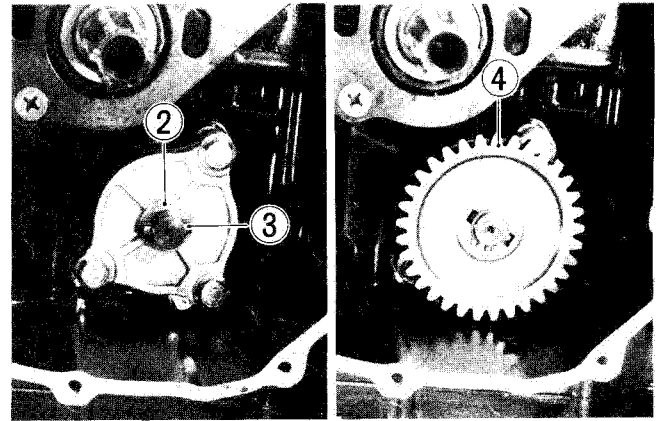

- Install the primary driven gear, needle bearing and spacer.

**NOTE:**

When reinstalling the spacer, be sure to face the screw holes outwards.

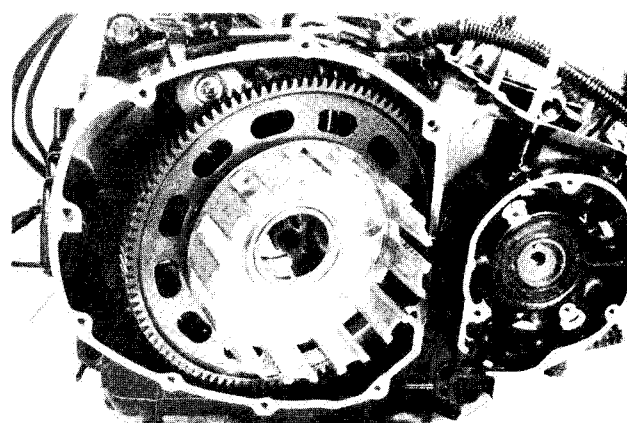

- Install the washer and clutch sleeve hub.

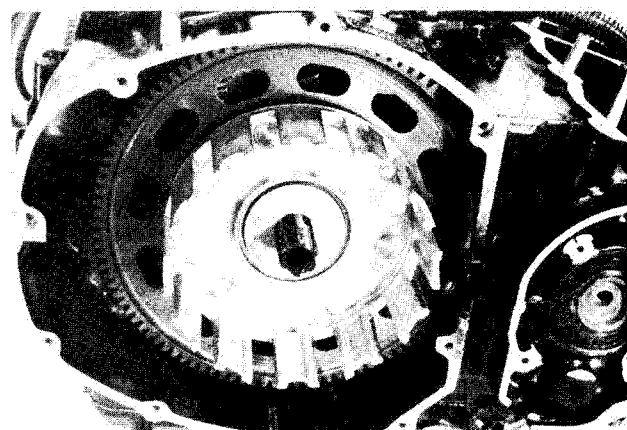

- After tightening the clutch sleeve hub nut, be sure to lock the nut by firmly bending the tongue of the washer. Tightening torque for the nut is specified.

Clutch sleeve hub nut tightening torque	50 – 70 N·m (5.0 – 7.0 kg·m)
09920-53710	Clutch sleeve hub holder

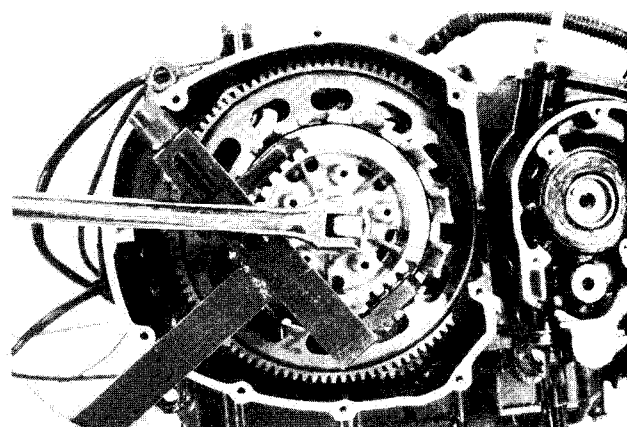

- Insert clutch driven plate and drive plate one by one into sleeve hub in the prescribed order, cork plate first.
- Install the clutch push rod in the countershaft.
- Fit the pressure plate into the sleeve hub.

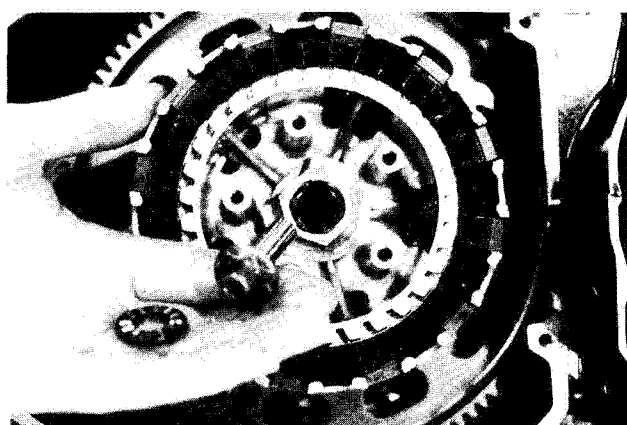

- Tighten the clutch spring set bolts in the order shown in the photo.

**NOTE:**

Tighten the clutch spring set bolts in the manner indicated, tightening them by degrees until they attain a uniform tightness.

Clutch spring bolt tightening torque	11 – 13 N·m (1.1 – 1.3 kg·m)
--------------------------------------	---------------------------------

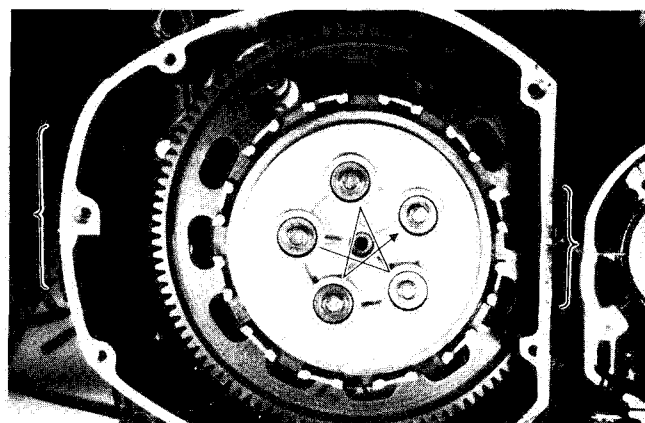

- Coat SUZUKI Bond No. 1207B lightly to the portion around mating surface between crank-cases as shown.

99000-31140	SUZUKI Bond No. 1207B
-------------	-----------------------

- Replace the clutch cover gasket with a new one to prevent oil leakage.
- Install the clutch cover.

**CAUTION:**

Use a new gasket on the two bolts (A) to prevent oil leakage.

- Install the signal generator stator with two screws and route its lead wire properly as shown in the figure.

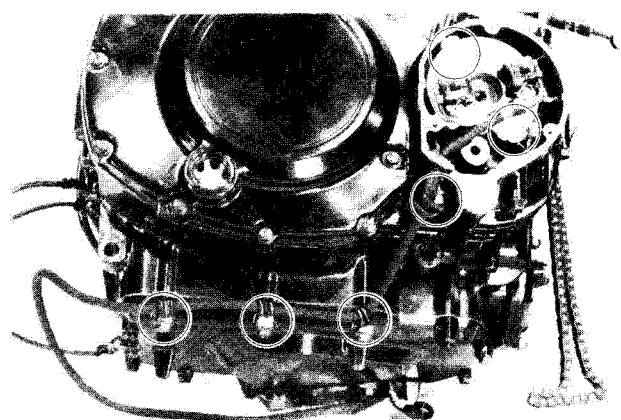
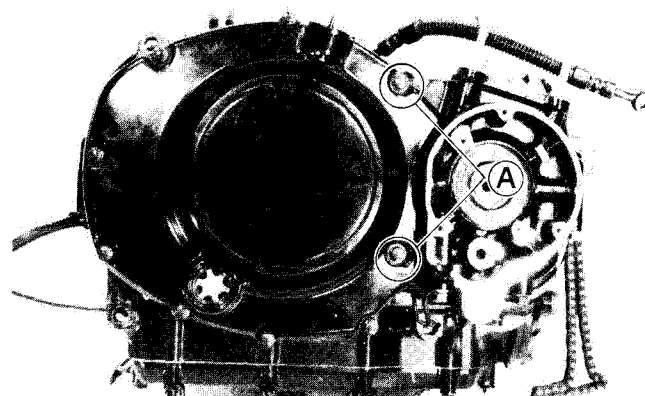

- Fit the slot (1) on the back surface of the rotor over the locating pin (2) at the end of the crankshaft.
- Hold the signal generator rotor and tighten the rotor securing bolt with 6-mm hexagon wrench.

Tightening torque	25 – 35 N·m (2.5 – 3.5 kg·m)
-------------------	---------------------------------

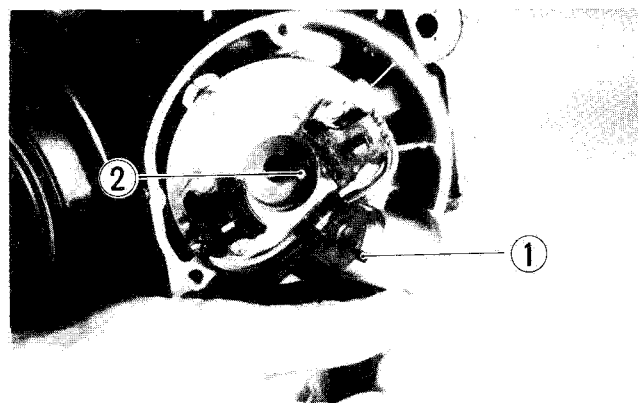

- Mount the piston ring in the order of oil ring, 2nd ring, and top ring.
- Top ring and 2nd (middle) ring differ in the shape of ring face, and the face of top ring is chrome-plated whereas that of 2nd ring is not. The color of 2nd ring appears darker than that of the top one.

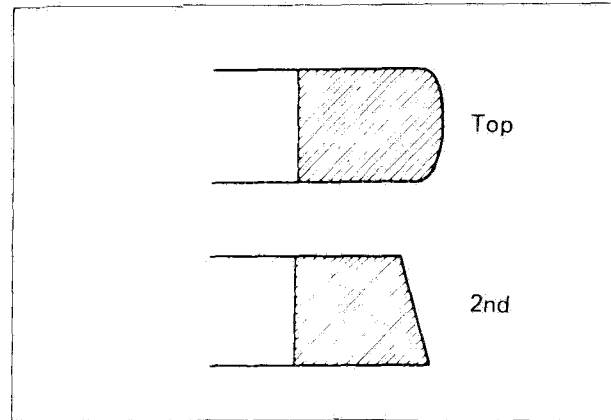

- Top and 2nd (middle) rings have letter "R" marked on the side. Be sure to bring the marked side to top when fitting them to the piston.

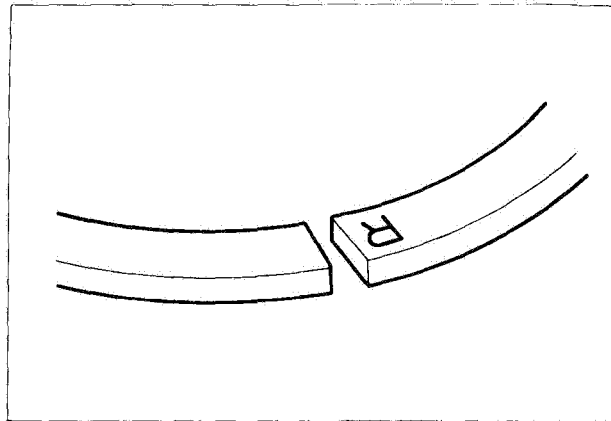

- The first member to go into the ring groove is spacer ①. After placing spacer, fit the two side rails ②. Side designations, top and bottom, are not applied to the spacer and side rails: you can position each either way.

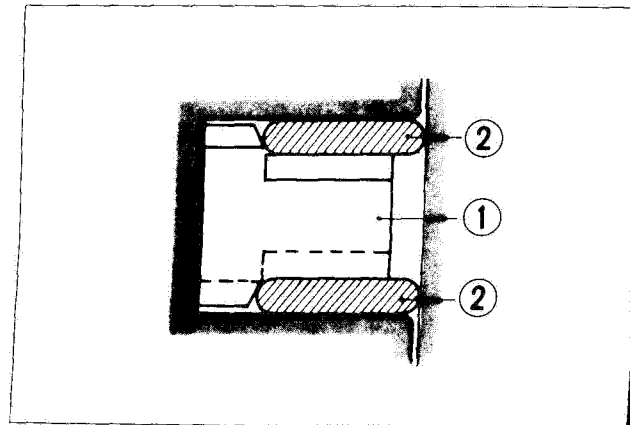

- Position the gaps of the three rings as shown. Before inserting each piston into the cylinder, check that the gaps are so located.

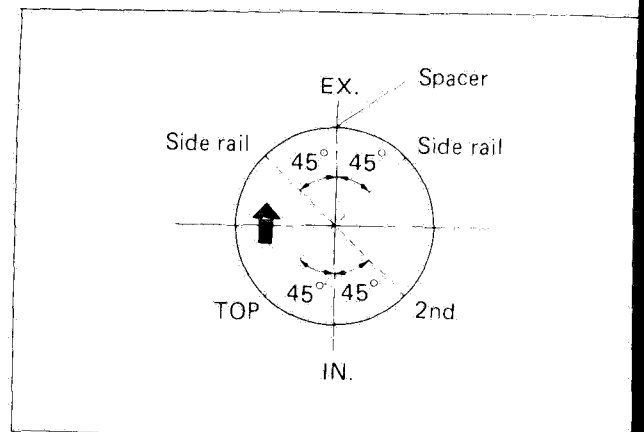

- The piston is in correct position when its triangle (on the crown) points forward.
- Be sure to install the pistons in the cylinder from which they were taken out in disassembly, refer to the letter mark, "1" through "4", scribed on the piston.
- Have each piston oiled lightly before installing it.

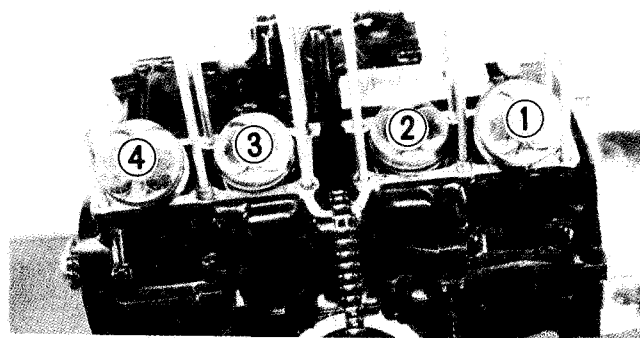

- Place a rag beneath the piston, and install the circlip.
- Be sure to use new circlips.
- Make sure that the conrod oil hole ① is located rearside.
- Place a new cylinder gasket on the crankcase.

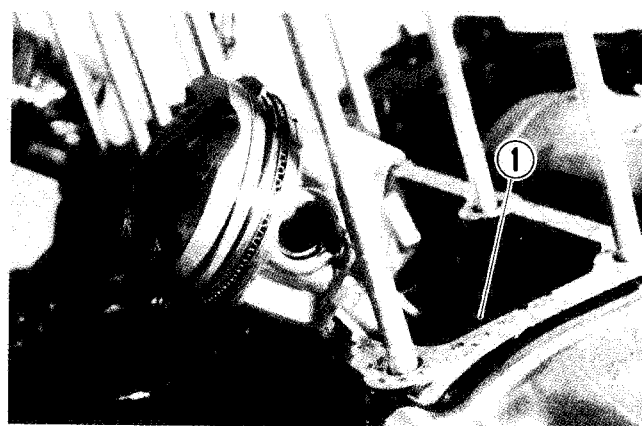

- Install piston ring holders in the indicated manner. Some light resistance must be overcome to lower the cylinder block.
- With No. 2 and No. 3 pistons in place, install No. 1 and No. 4 pistons, and insert them into the cylinder.

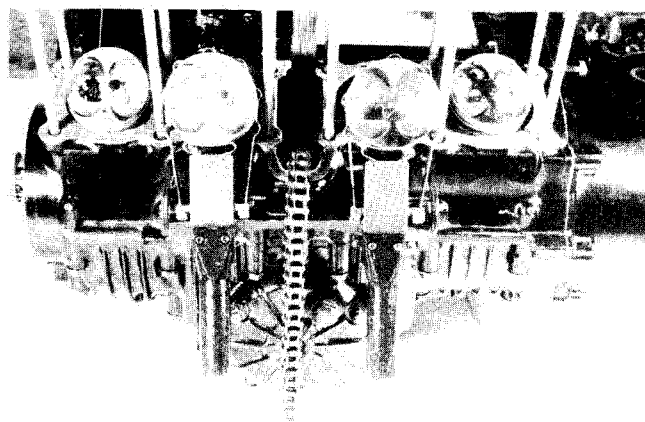

09916-74520	Holder body
09916-74530	Band (bore 55 – 65 mm)

**NOTE:**

- \* Do not overtighten the special tool bands or the cylinders will resist to admit the pistons.
- \* Each band has a number punchmarked on it. The number refers to a particular range of piston sizes.

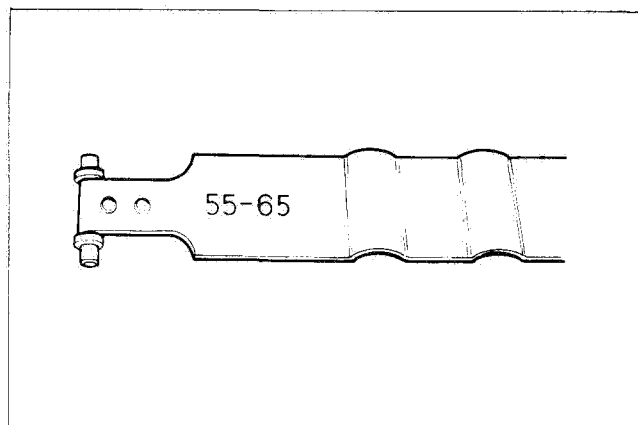



- Be sure to replace the cylinder head gasket with a new one to prevent gas leakage.

**NOTE:**

Be sure to identify the "printed" surface of the cylinder head gasket and install this surface to the cylinder head.

- Fix two knock pins properly.
- Tighten the twelve 8-mm nuts to specification with a torque wrench sequentially in the ascending order of numbers.

09911-74520	Long socket 12-mm
09914-24510	T handle

Cylinder head nut Tightening torque	25 – 29 N·m (2.5 – 2.9 kg·m)
--	---------------------------------

- After firmly tightening the 12-nuts, install one 6 mm bolt (A) and tighten it with specified torque.

Tightening torque	8 – 12 N·m (0.8 – 1.2 kg·m)
-------------------	--------------------------------

- Place chain guide (1) properly.
- Replace the oil pipe O-rings with new ones.
- Install the right and left oil pipes with allen bolts securely.

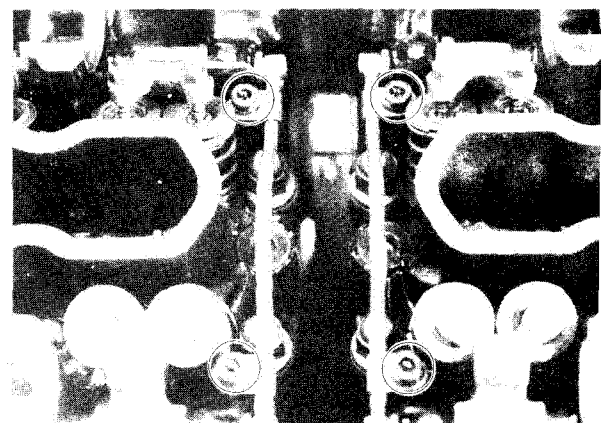
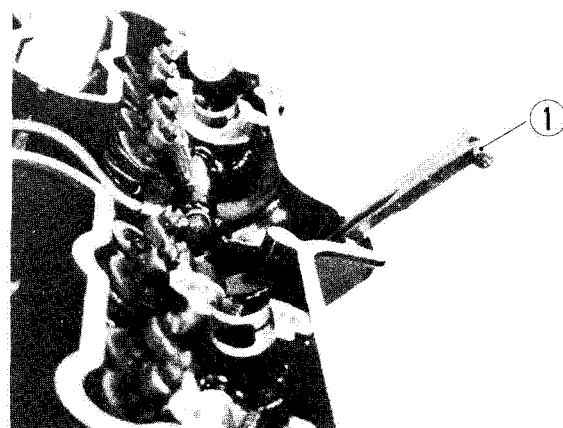
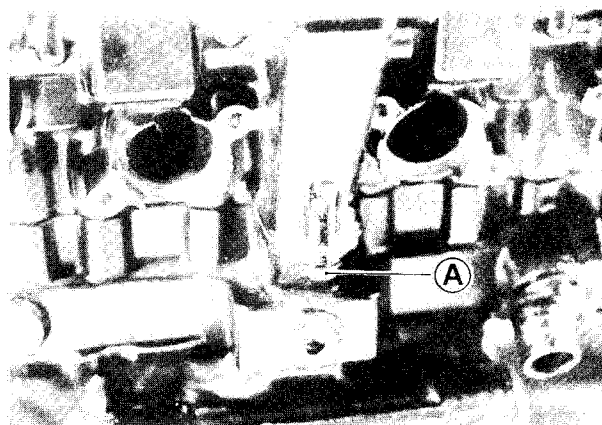
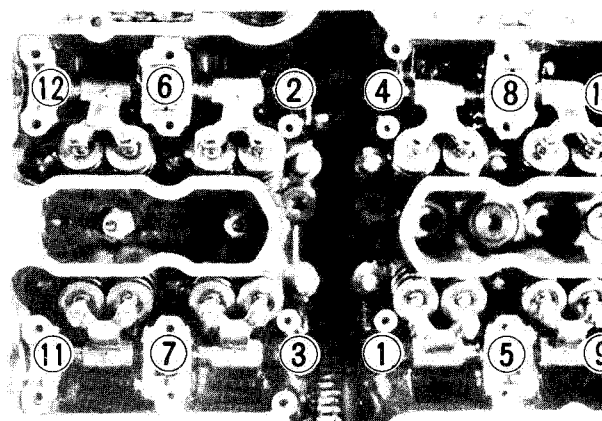

- Install the right and left oil hoses to the crankcase and to the cylinder head with union bolts. Place the washers on the both sides of each union.

Tightening torque	N·m	kg·m
① 10 mm union	20 – 24	2.0 – 2.4
② 8 mm union	8 – 12	0.8 – 1.2

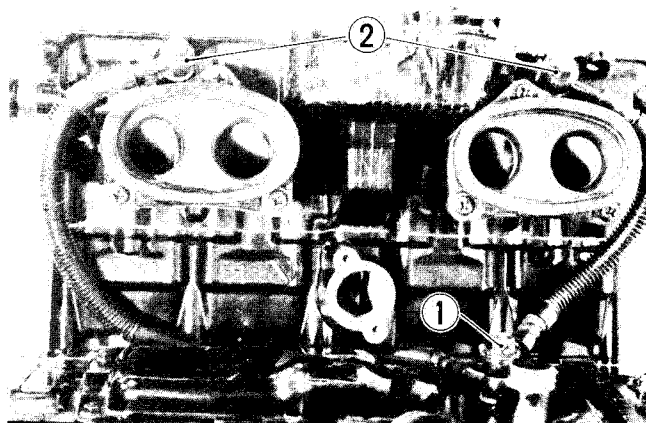

- While holding down the timing chain, rotate the crankshaft in normal direction to bring the "T" mark of the rotor to the timing mark.

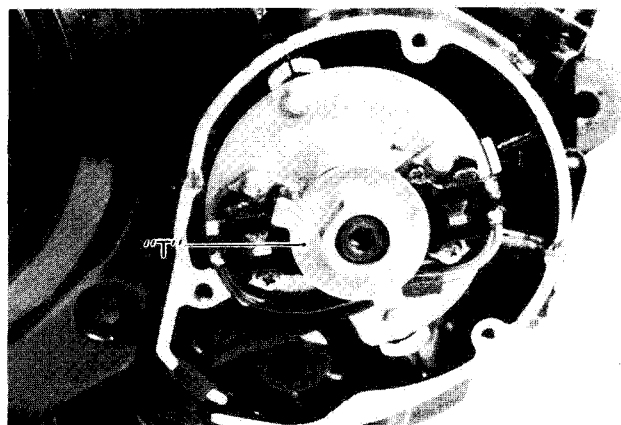

- The exhaust camshaft can be distinguished from that of the intake by the embossed letters "EX" (for exhaust) as against letters "IN" (for intake). The right end can be distinguished by the notch ①.

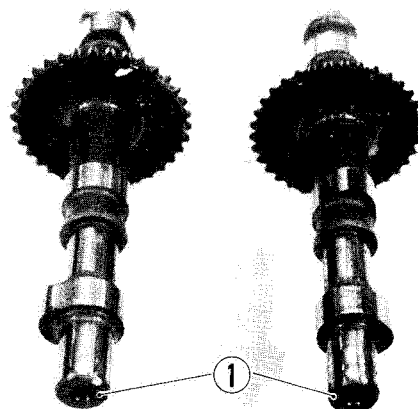
**NOTE:**

Just before placing the camshaft on the cylinder head, apply high quality molybdenum disulfide lubricant to its journals, fully coating each journal ② with the paste taking care not to leave any dry spot. Apply engine oil to the journal bearings.

99000-25140

SUZUKI Moly Paste

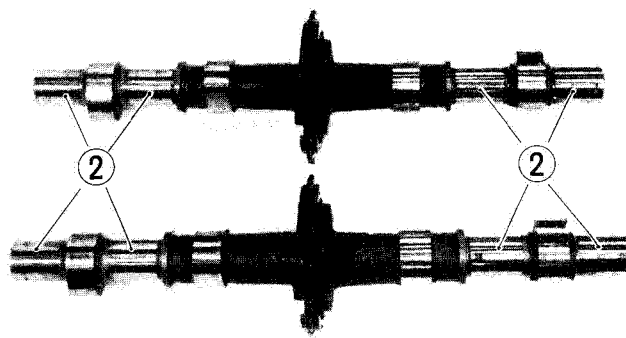

- With "T" mark accurately lined up with the timing mark, hold the crankshaft steady and lightly pull up the chain to remove the slack between the crank sprocket and exhaust sprocket.
- Exhaust sprocket bears an arrow marked "1" indicated as ①. Turn over the exhaust camshaft so that the arrow points flush with the gasketed surface of the cylinder head. Engage the timing chain with this sprocket.
- The other arrow marked "2" is now pointing straight upward. Count the chain roller pins toward the intake camshaft, starting from the roller pin directly above this arrow marked "2" and ending with the 19th roller pin. Engage the chain with intake sprocket, locating the 19th pin at and above the arrow marked "3" on the intake sprocket.

**NOTE:**

The timing chain is now riding on all three sprockets. Be careful not to disturb the crankshaft until the eight holders and chain tensioner adjuster are secured.

- Each camshaft holder is identified with a cast-on letter with a triangle. A matching cast-on symbol appears on the head. Install each holder at its matching letter, with triangle symbols pointing forward.
- Secure the four camshaft journal holders evenly by tightening the camshaft journal holder bolts sequentially. Try to equalize the pressure by moving the wrench diagonally from one bolt to another and from one camshaft journal holder to another, to push shafts down evenly.

**NOTE:**

Damage to head or cam journal holder thrust surfaces may result in the situation that cam journal holders are not drawn down evenly.

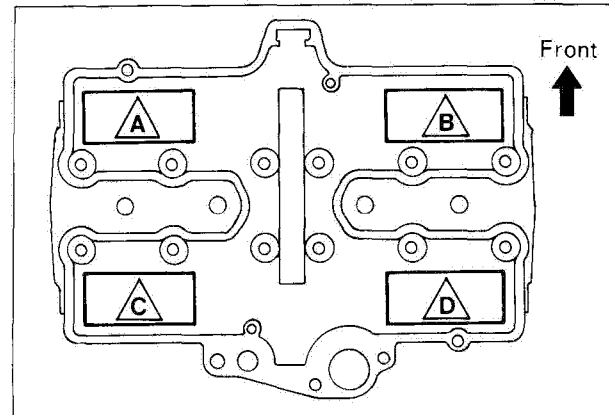
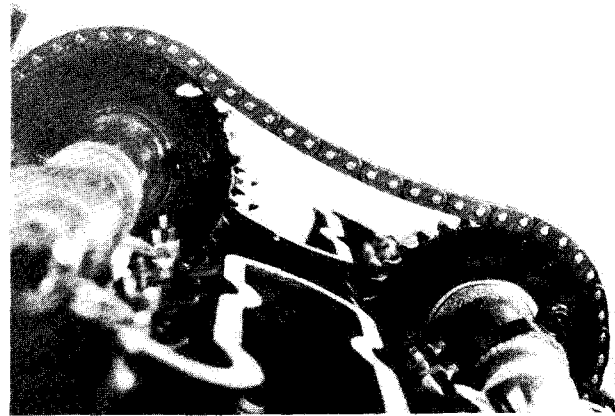
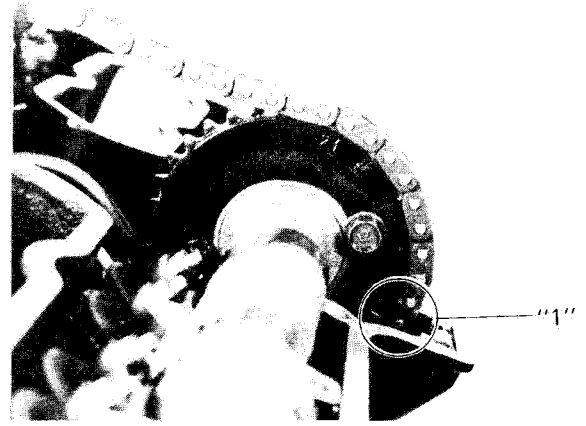

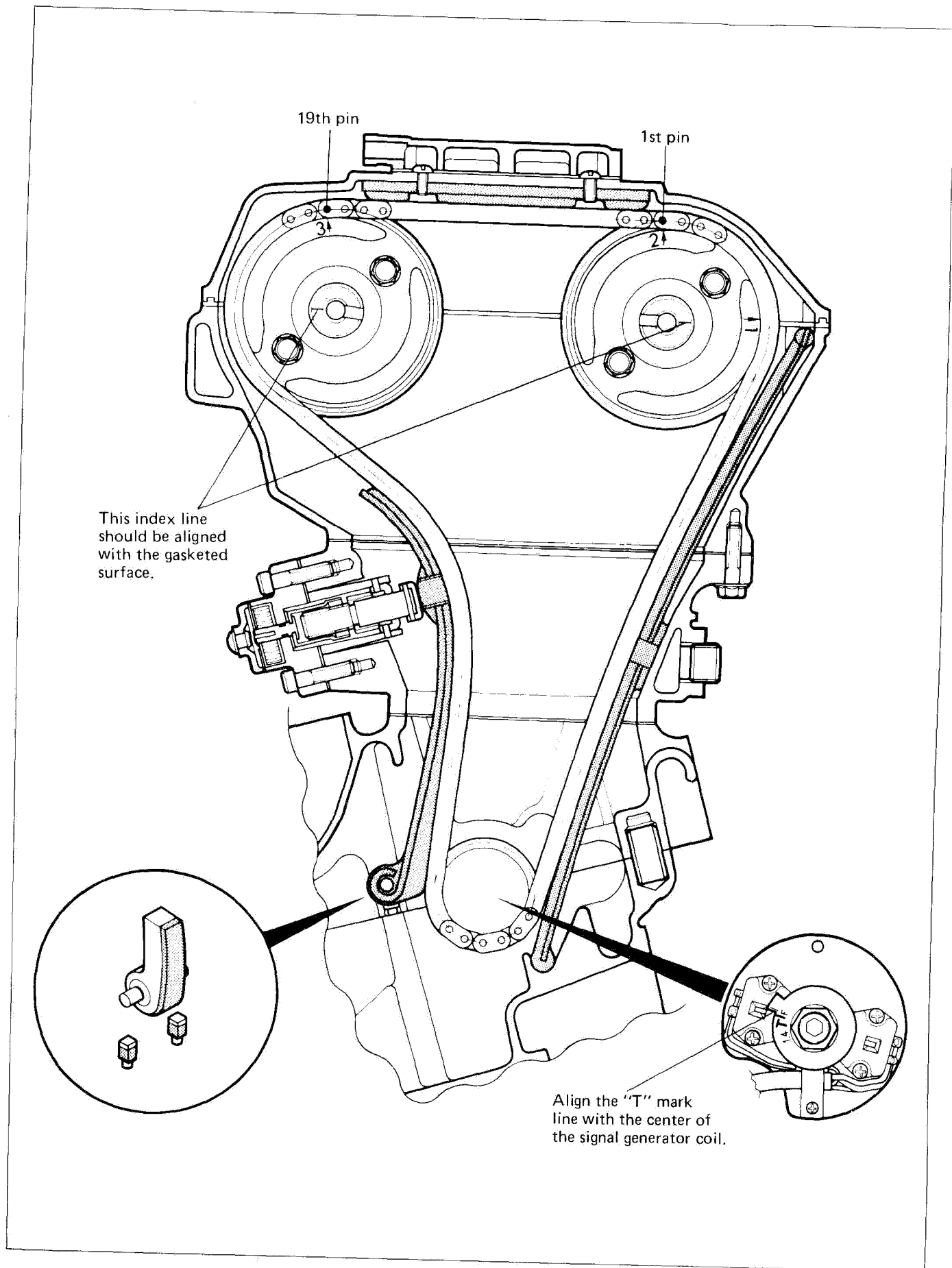

- Tighten the camshaft journal holder bolts to the following torque value:

**CAUTION:**

The camshaft journal holder bolts are made of a special material and much superior in strength compared with other type of high strength bolts.

Take special care not to use other types of bolts instead of these special bolts. To identify these bolts, each of them has a figure "9" on its head.

Camshaft journal holder bolt tightening torque	10 – 14 N·m (1.0 – 1.4 kg·m)
--	---------------------------------

- While turning the lock screw clockwise with plain screw driver, push in the pushrod all the way. Keep on turning the screw until it refuses to turn further.
- Secure the tensioner adjuster to the cylinder block with 5 mm hexagon wrench.

Tightening torque	6 – 8 N·m (0.6 – 0.8 kg·m)
-------------------	-------------------------------

- Remove the screw driver from the lock screw and check that the cam drive chain is stretched without play.
- Adjust the valve clearance.  
(Refer to page 2-6).
- In fitting the seal ring to the oil filter chamber cap, lightly coat grease on the seal ring groove ① to avoid any chance of dropping or mislocating the ring during the installation work.
- Tighten the engine oil drain plug.
- Pour 50 ml of engine oil in the oil pockets of the head.

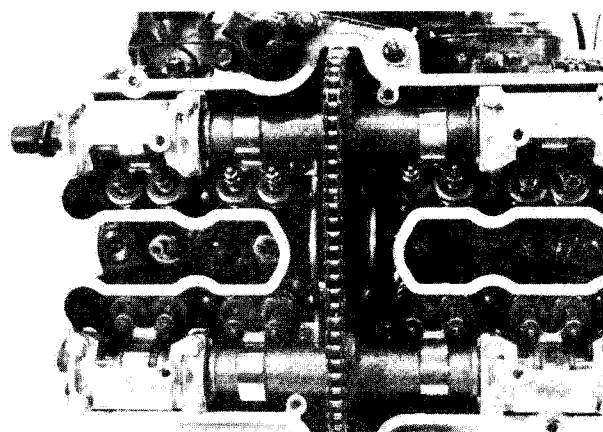
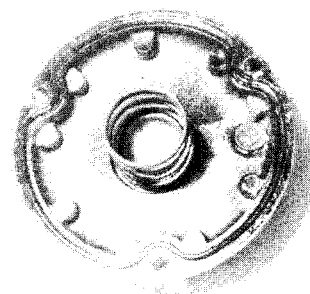
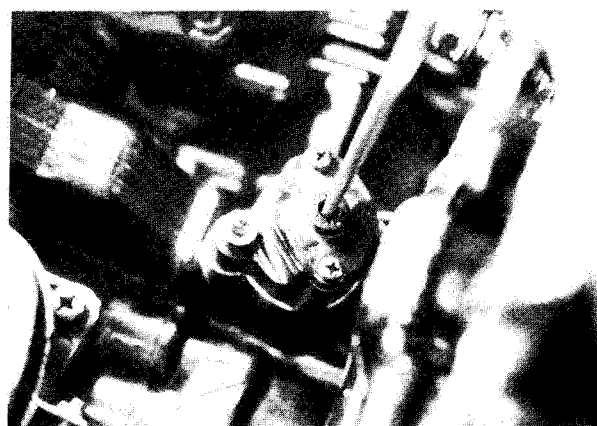
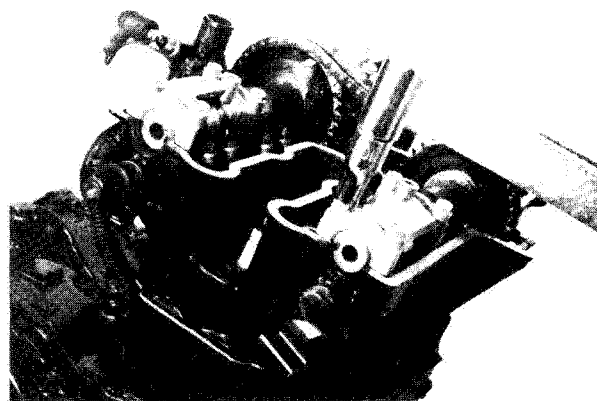

- Install the cylinder head cover and cover cap.  
When reinstalling the cylinder head cover, apply SUZUKI Bond No. 1207B to the mating surface between oil seal and head cover and four camshaft end seals.

99000-31140	SUZUKI Bond No. 1207B
-------------	-----------------------

Cylinder head cover tightening torque	11 – 13 N·m (1.1 – 1.3 kg·m)
---------------------------------------	---------------------------------

**NOTE:**

Always install a new gasket to the cylinder head cover bolts.

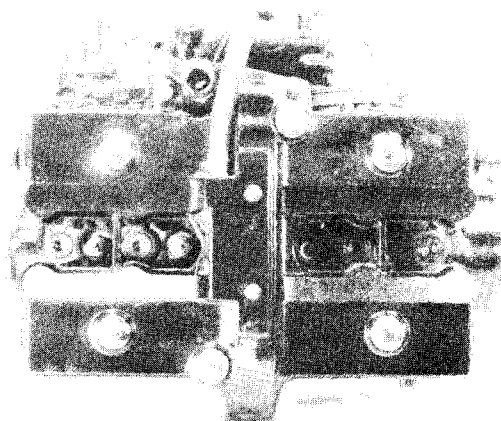
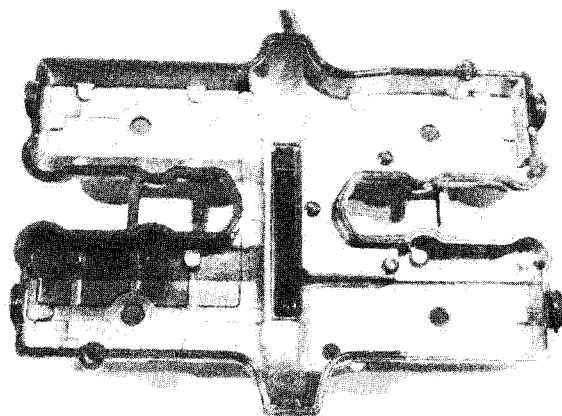

- When installing the thermo-switch, apply Bond No. 1207B to the thermo-switch.

99000-31140	SUZUKI Bond No. 1207B
-------------	-----------------------

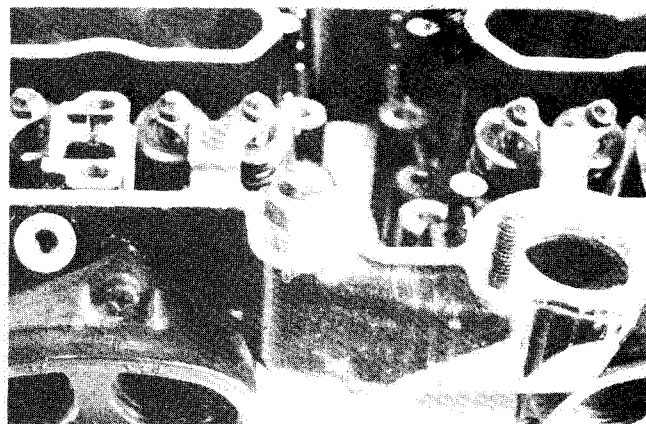

- Install new O-ring to the intake pipe groove as shown:

**CAUTION:**

Always use new O-rings to prevent sucking air from the joint part.

- Install each intake pipe to the cylinder head properly.

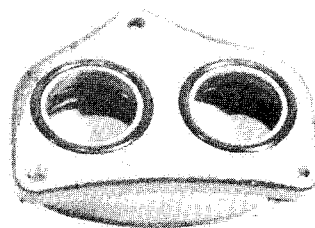

# FUEL AND LUBRICATION SYSTEM

## CONTENTS

<b>FUEL COCK</b> .....	4- 1
<b>CARBURETOR</b> .....	4- 2
<b>SPECIFICATIONS</b> .....	4- 3
<b>DIAPHRAGM AND PISTON OPERATION</b> .....	4- 4
<b>SLOW SYSTEM</b> .....	4- 5
<b>MAIN SYSTEM</b> .....	4- 6
<b>STARTER SYSTEM</b> .....	4- 7
<b>FLOAT SYSTEM</b> .....	4- 7
<b>DISASSEMBLY</b> .....	4- 8
<b>NEEDLE VALVE INSPECTION</b> .....	4-10
<b>FLOAT HEIGHT ADJUSTMENT</b> .....	4-11
<b>REASSEMBLY</b> .....	4-11
<b>FUEL LEVEL INSPECTION</b> .....	4-13
<b>BALANCING CARBURETORS</b> .....	4-14
<b>LUBRICATION SYSTEM</b> .....	4-16
<b>OIL PRESSURE</b> .....	4-16
<b>OIL SUMP FILTER</b> .....	4-16
<b>OIL LEVEL SWITCH</b> .....	4-16
<b>LUBRICATION SYSTEM CHART</b> .....	4-17

## FUEL COCK AND STRAINER

A valve is provided at the top of the fuel cock lever and can switch over to "OFF", "ON" and "RES". With the valve "ON" or "RES" the main passage opens, with the valve "OFF" both holes closes.

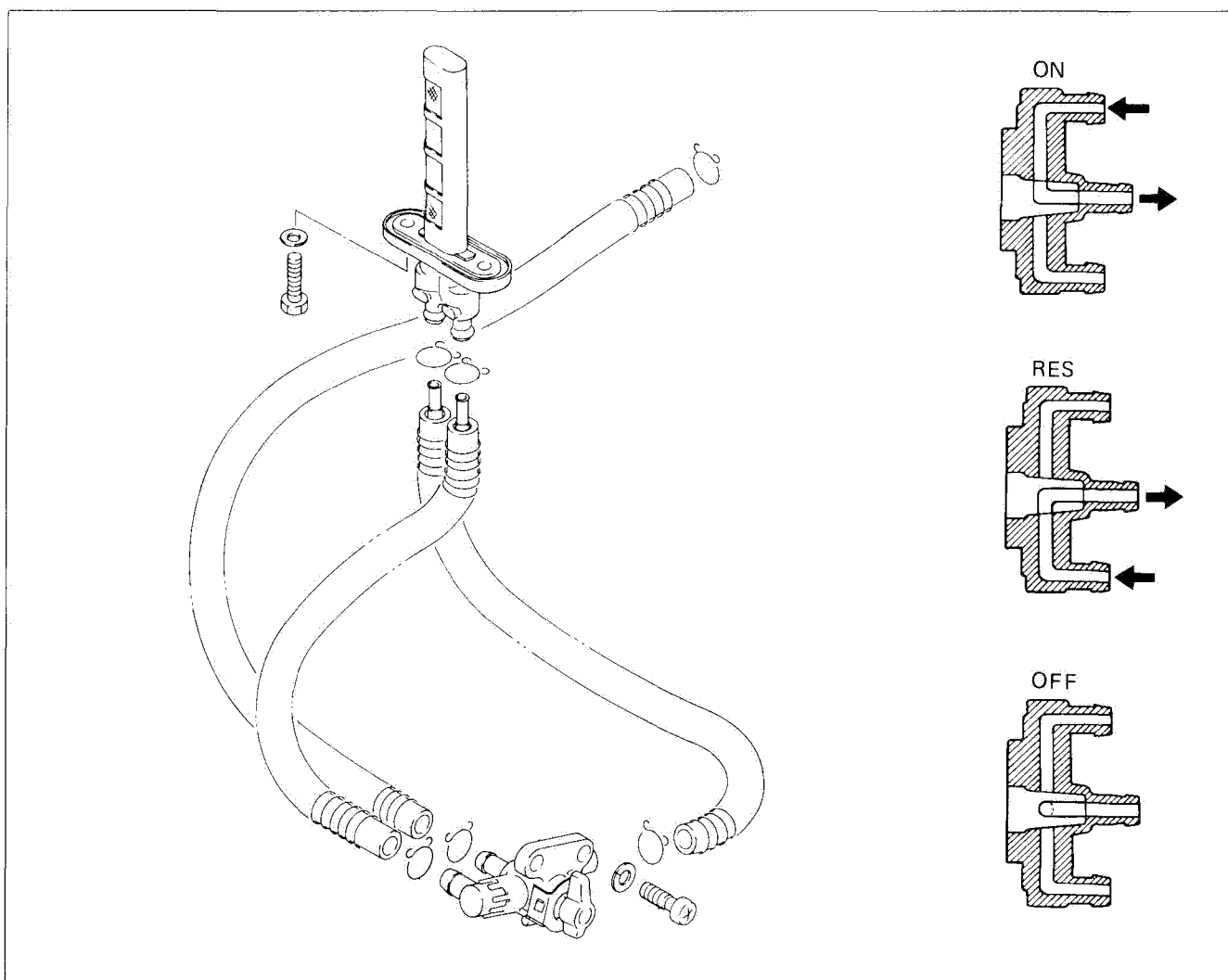

### INSPECTION AND CLEANING

If the fuel strainer is dirty with sediment or rust fuel will not flow smoothly and loss in engine power may result. Clean the fuel strainer in the following manner.

- Turn the fuel cock to RES position and drain fuel completely.
- Shift the fuel hose clip sideways and disconnect the fuel hoses from the fuel strainer.
- Remove the fuel cock assembly by removing the two bolts.
- Clean the fuel strainer with compressed air.

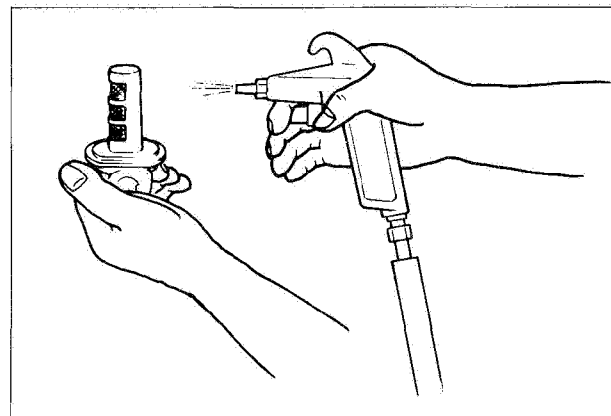

#### WARNING:

Gasoline is very explosive. Extreme care must be taken.

Gasket must be replaced with a new one to prevent fuel leakage.



# CARBURETOR

## CARBURETOR CONSTRUCTION

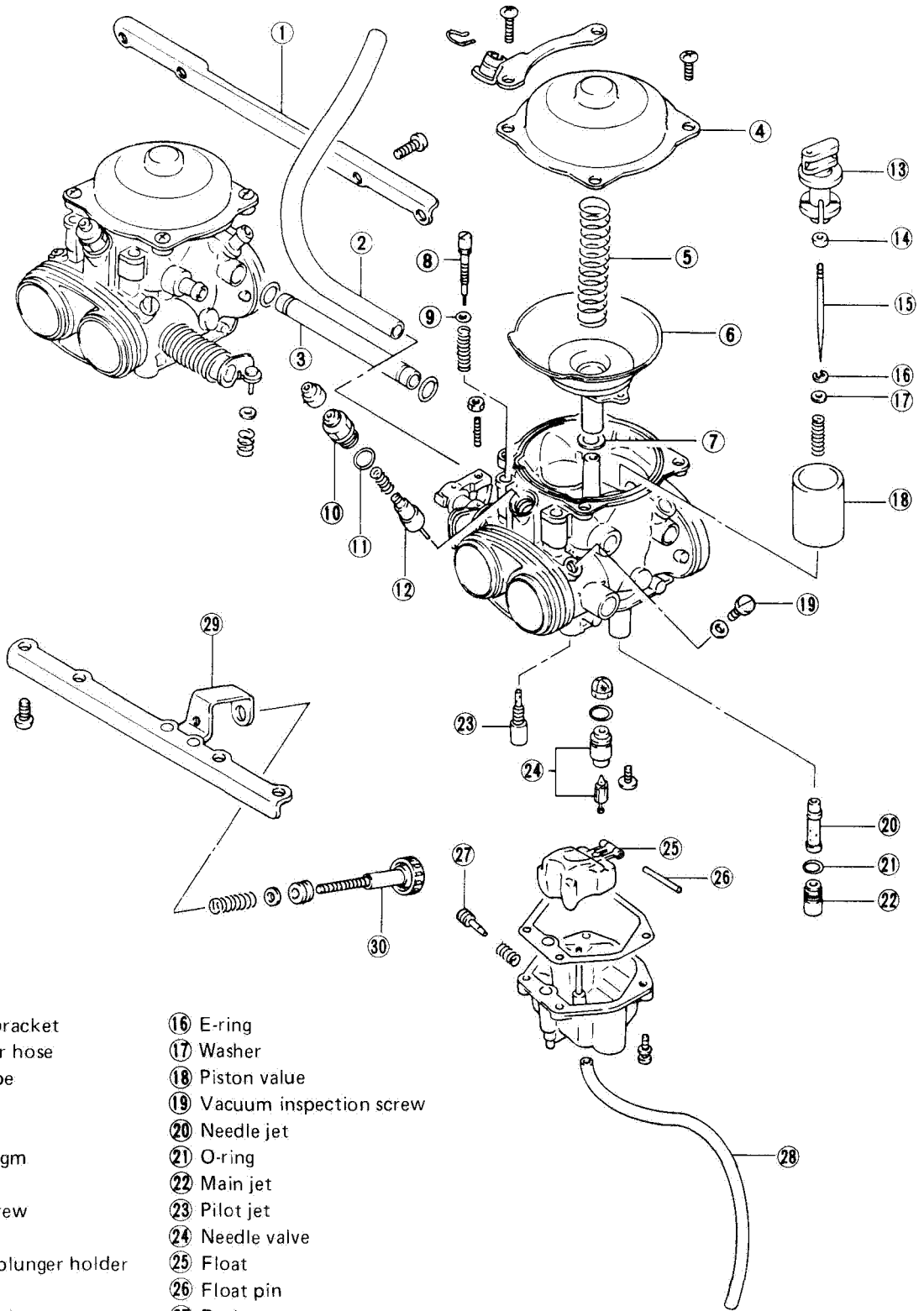

- |                 |                          |                            |                  |
|-----------------|--------------------------|----------------------------|------------------|
| ① Upper bracket | ⑩ Starter plunger holder | ①⑥ E-ring                  | ②③ Pilot jet     |
| ② Breather hose | ⑪ O-ring                 | ①⑦ Washer                  | ②④ Needle valve  |
| ③ Fuel pipe     | ⑫ Starter plunger        | ①⑧ Piston valve            | ②⑤ Float         |
| ④ Cap           | ⑬ Jet needle holder      | ①⑨ Vacuum inspection screw | ②⑥ Float pin     |
| ⑤ Spring        | ⑭ Spacer                 | ②⑦ Needle jet              | ②⑦ Drain screw   |
| ⑥ Diaphragm     | ⑮ Jet needle             | ②⑧ Main jet                | ②⑧ Drain hose    |
| ⑦ Washer        |                          | ②⑨ Pilot jet               | ②⑨ Lower bracket |
| ⑧ Pilot screw   |                          | ②⑩ Needle valve            | ③① Idle adjuster |
| ⑨ O-ring        |                          | ②⑪ Float                   |                  |

**SPECIFICATIONS**

ITEM	SPECIFICATIONS
Type	AISAN AS 27VW
I.D. No.	04A10
Bore	27 mm
Idle r/min	1 300 ± 100 r/min.
Fuel level	9.0 ± 0.5 mm
Float height	20.5 ± 1.0 mm
Main jet	#94
Main air jet	1.2 mm
Jet needle	5B10-3rd
Needle jet	2.60 mm
Throttle valve	11.0
Pilot jet	#34
By-pass	0.8, 0.8, 0.8 mm
Pilot outlet	0.8 mm
Valve seat	2.5 mm
Starter jet	GS <sub>1</sub> #60, GS <sub>2</sub> #54
Pilot screw	PRE-SET (2 turn out)
Pilot air jet	1.35 mm
Throttle cable play	0.5 – 1.0 mm
Choke cable play	0.5 – 1.0 mm

**I.D. NO. LOCATION**

Each carburetor has I.D. Number ① stamped on the carburetor body according to its specifications.

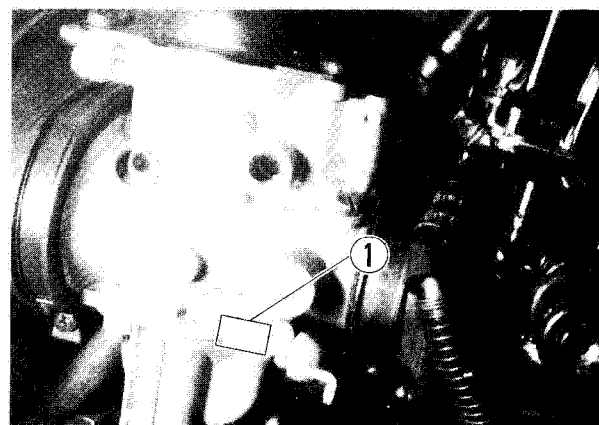

## DIAPHRAGM AND PISTON OPERATION

The carburetor is of a variable-venturi type, whose venturi cross section area is increased or decreased automatically by the piston according to the vacuum present on the downstream side of the venturi. Vacuum is admitted into the diaphragm chamber through an orifice provided in the sliding shaft guide.

Rising vacuum controls the diaphragm movement, causing the piston to rise to increase the said area and thus prevent the air velocity from increasing. Thus, air velocity in the venturi passage is kept relatively constant for improved fuel atomization and for securing an optimum ratio of fuel to air in the mixture.

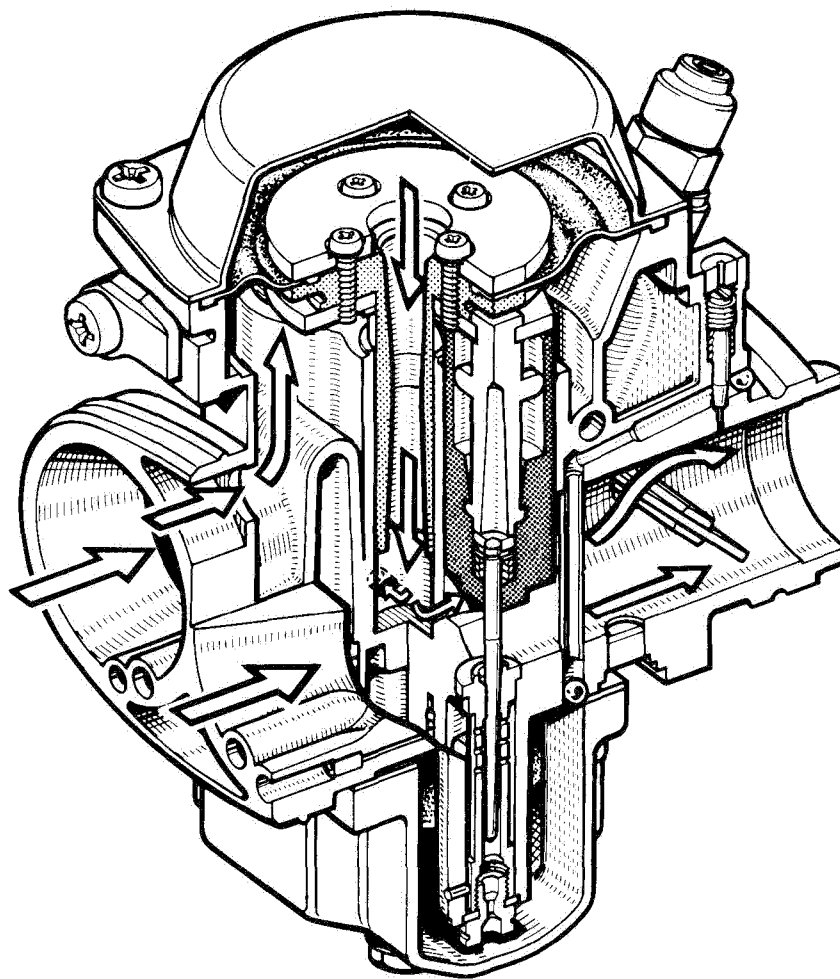

## SLOW SYSTEM

This system supplies fuel during engine operation with throttle valve closed or slightly opened. The fuel from the float chamber is first passed and metered by the pilot jet where it mixes with air coming in through pilot air jet.

This mixture, rich with fuel, then goes up through pilot pipe to pilot screw. A part of the mixture is discharged into the main bore out of by-pass ports. The remainder is then metered by pilot screw and sprayed out into the main bore through pilot outlet.

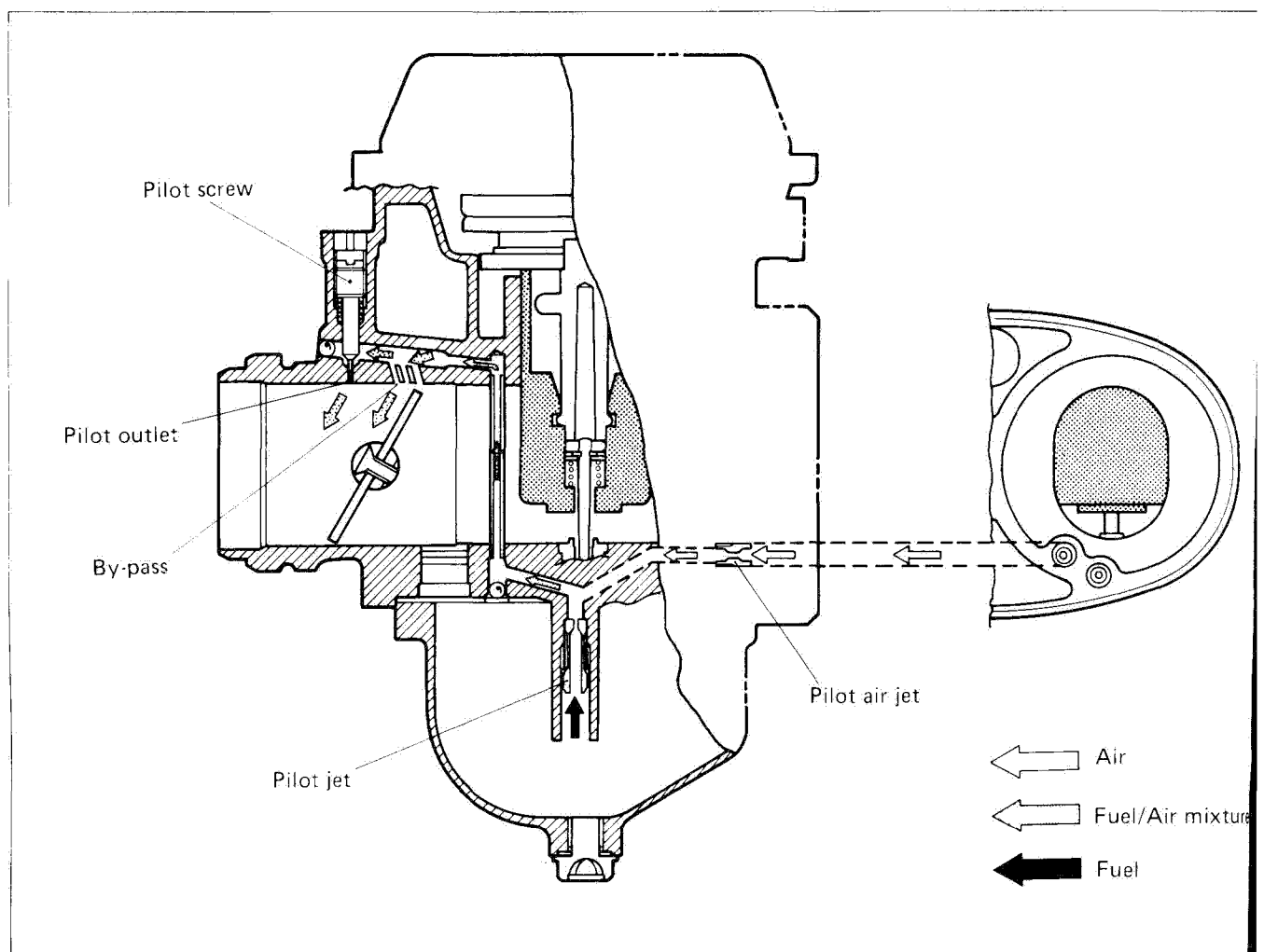

## MAIN SYSTEM

As throttle valve is opened, engine speed rises, and this increases vacuum in the venturi. Consequently the piston valve moves upward.

Meanwhile, the fuel in float chamber is metered by main jet, and the metered fuel enters needle jet, in which it mixes with the air admitted through main air jet to form an emulsion.

The emulsified fuel then passes through the clearance between needle jet and jet needle, and is discharged into the venturi, in which it meets main air stream being drawn by the engine.

Mixture proportioning is accomplished in needle jet; the clearance through which the emulsified fuel must flow is large or small, depending ultimately on throttle position.

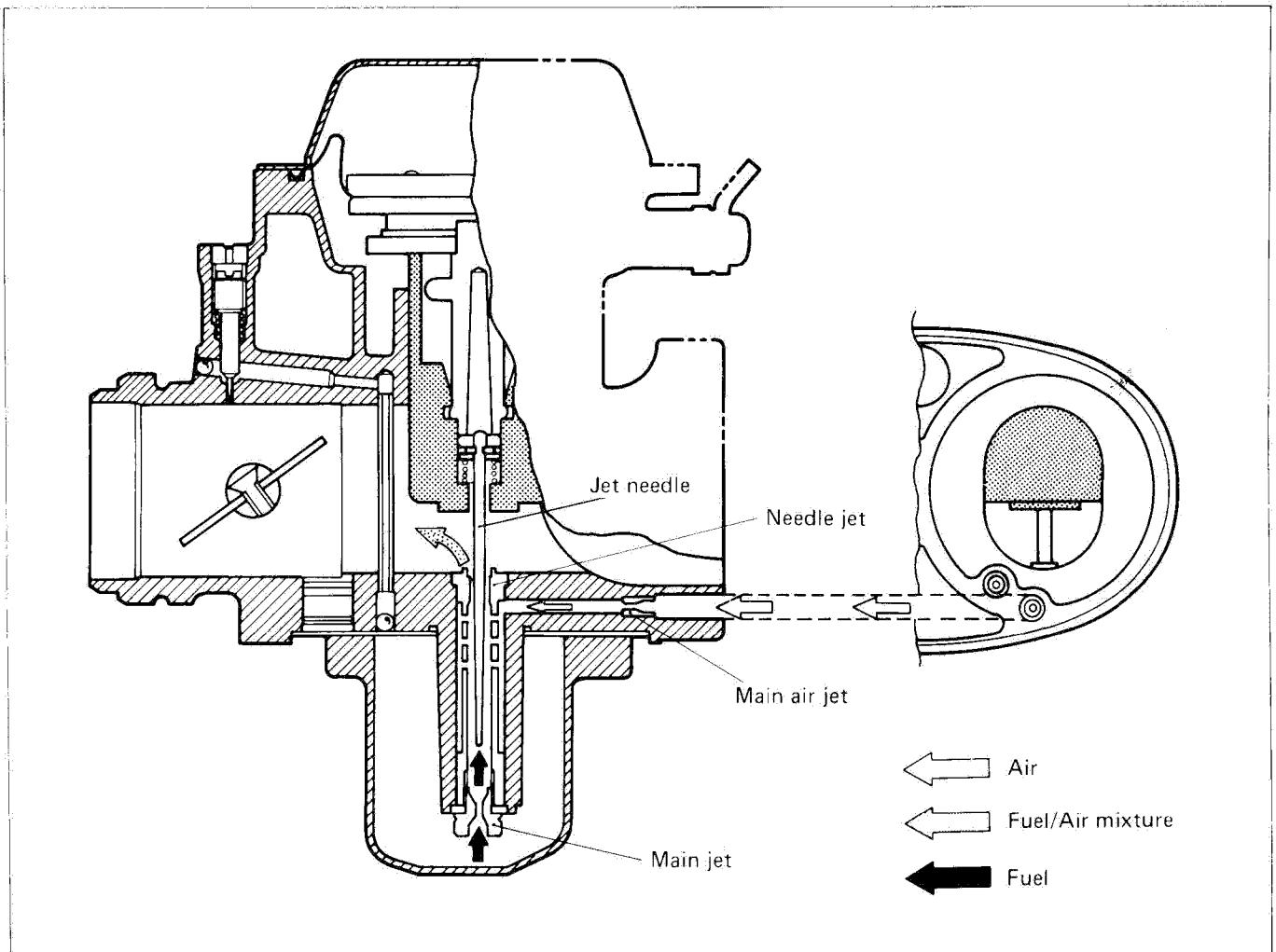

## STARTER SYSTEM

Turning the choke lever allows starting plunger to draw fuel into the starter circuit from the float chamber through starter jet.

Starter jet meters this fuel, which then flows into starter pipe and mixes with the air coming from the float chamber. The mixture, rich in fuel content, reaches starting plunger and mixes again with the air coming through a passage extending from behind the diaphragm.

The two successive mixings of fuel with air are such that a proper fuel/air mixture for starting is produced when the mixture is sprayed out through starter outlet into the main bore.

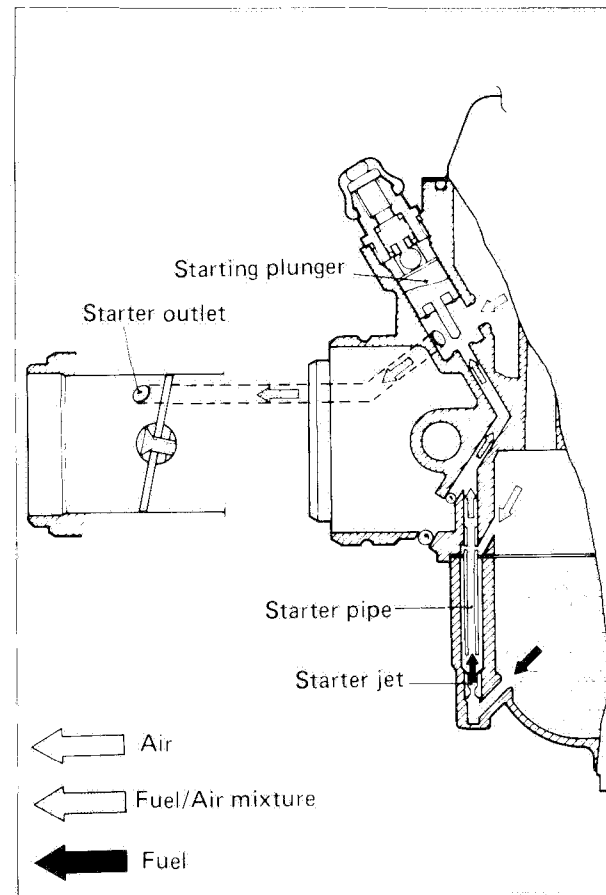

## FLOAT SYSTEM

Floats and needle valve are associated with the same mechanism, so that, as the floats move up and down, the needle valve also moves likewise. When fuel level is up in float chamber, floats are up and needle valve remains pushed up against valve seat. Under this condition, no fuel enters the float chamber.

As the fuel level falls, floats go down and needle valve unseats itself to admit fuel into the chamber. In this manner, needle valve admits and shuts off fuel alternately to maintain a practically constant fuel level inside the float chamber.

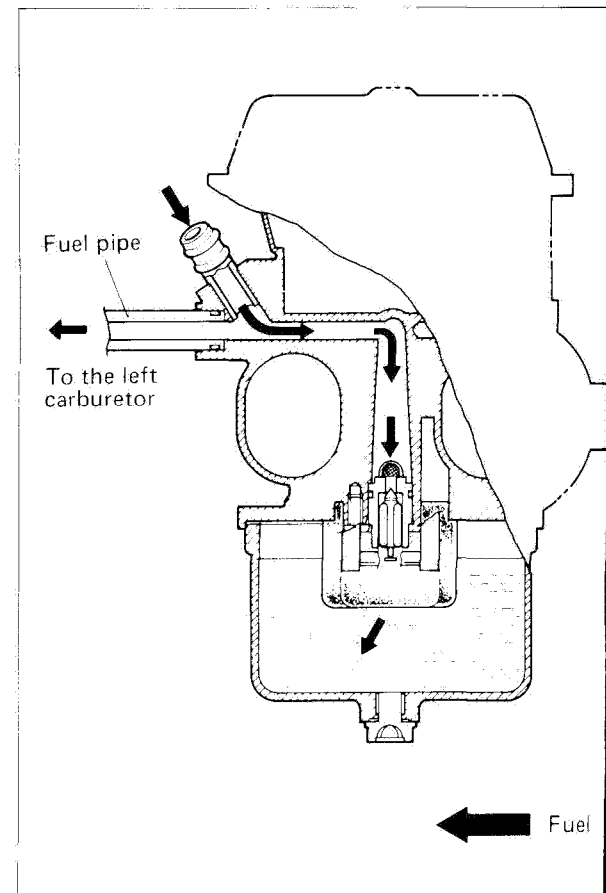

**DISASSEMBLY**

- Remove the carburetor set upper plate ① by unscrewing four screws.

09900-09003	Impact driver set
-------------	-------------------

L R  
 94 98 94 98  
 main Jet main Jet  
 sizes Pilot Jets sizes

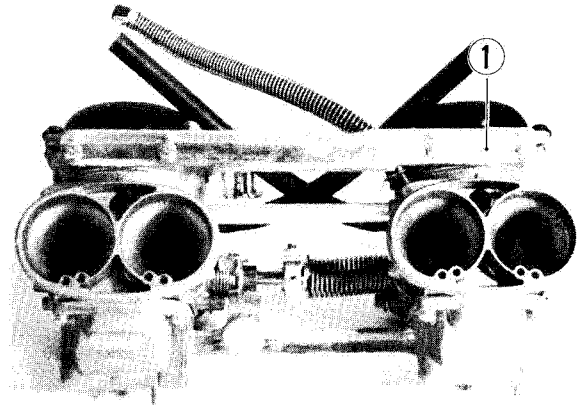

- Remove the carburetor set lower plate ② by unscrewing four screws.
- Separate the two carburetors.

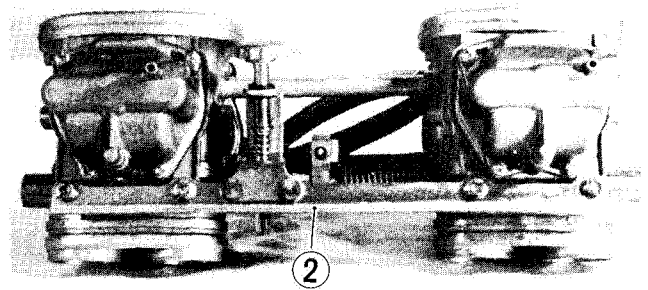

- Remove the top cap by unscrewing four screws.
- Pull out the diaphragm assembly.

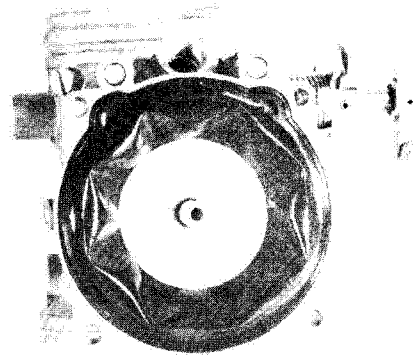

- Remove the two pistons ③ from piston holder ④.

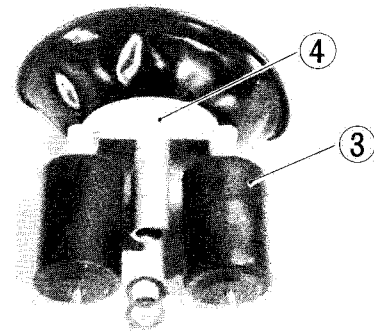

- After removing the jet needle holder ① by pulling with long-nose pliers, take out the jet needle related parts.

- ① Jet needle holder
- ② Spacer
- ③ E-ring
- ④ Washer
- ⑤ Spring
- ⑥ Jet needle
- ⑦ Piston valve

**CAUTION:**

Once remove the jet needle holder, it may be damaged and replace it with a new one.

- Remove the float chamber body by unscrewing four screws.

- Pull out the float pin and remove the float.

**CAUTION:**

When removing the float pin, be careful not to damage the carburetor body.

- Remove the needle valve ①, main jets ② and pilot jets ③.

**NOTE:**

When replacing the main jets, check their size and install them to the proper positions.

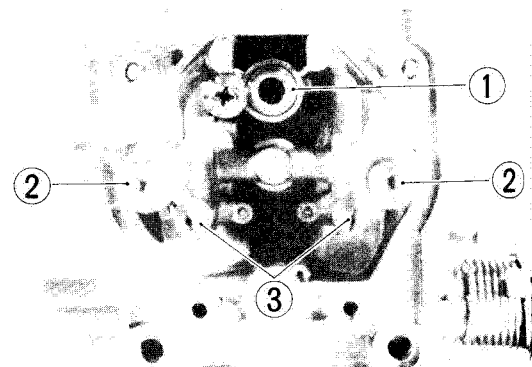
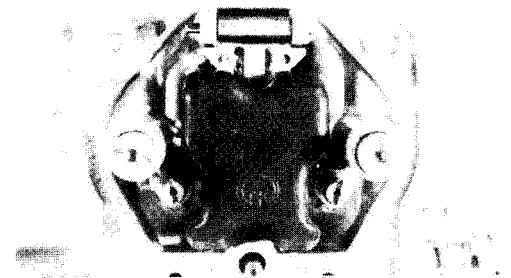
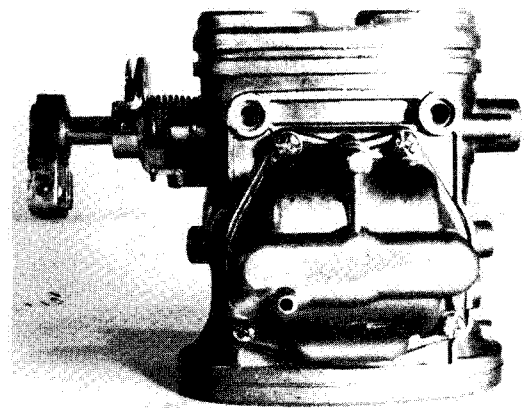
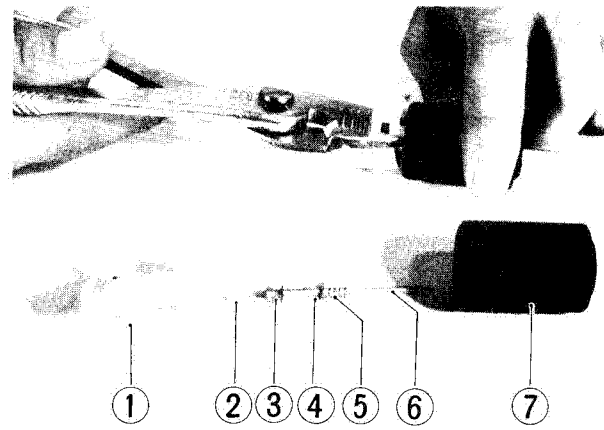



- Remove the four screws, and pull out the throttle valves ① by turning the throttle valve shaft.

09900-09003	Impact driver set
-------------	-------------------

**CAUTION:**  
 These four screws are locked by punching its end. Once removing the screws, they will be damaged.

- Remove the throttle valve shaft after removing E-ring.
- Check following items for any damage or clogging.
  - \* Pilot jet
  - \* Main jet
  - \* Main air jet
  - \* Pilot air jet
  - \* Needle jet air bleeding hole
  - \* Float
  - \* Needle valve mesh and O-ring
  - \* Diaphragm

**NEEDLE VALVE INSPECTION**

If foreign matter is caught between the valve seat and the needle, the gasoline will continue flowing and cause it to overflow. If the seat and needle are worn beyond the permissible limits, similar trouble will occur. Conversely, if the needle sticks, the gasoline will not flow into the float chamber. Clean the float chamber and float parts with gasoline. If the needle is worn as shown in the illustration, replace it together with a valve seat. Clean the fuel passage of the mixing chamber with compressed air.

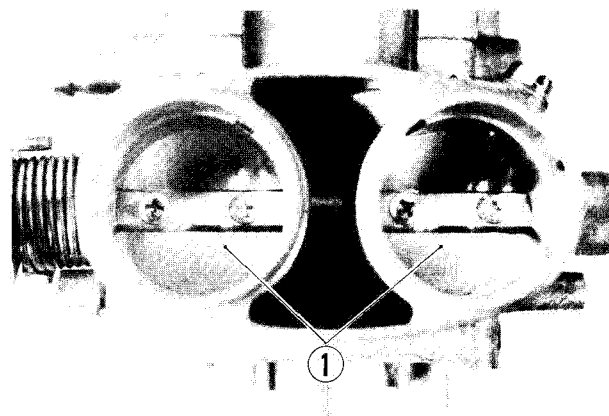

- \* Gasket
- \* Throttle valve shaft oil seals
- \* Drain plug gasket
- \* Pilot outlet and by-pass holes
- \* Fuel pipe O-ring

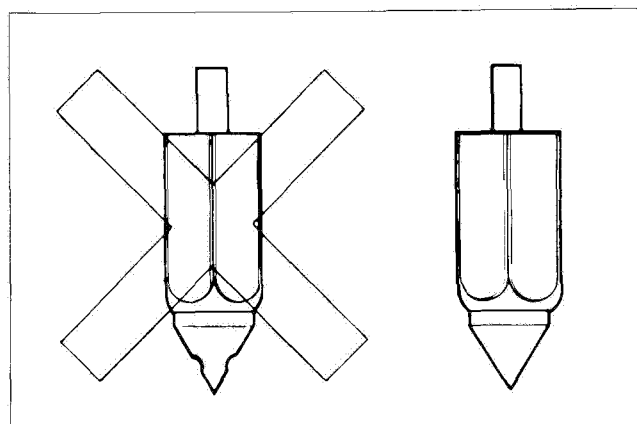

## FLOAT HEIGHT ADJUSTMENT

To check the float height, invert the carburetor body, with the float arm kept free, measure the height **A** while float arm is just in contact with needle valve by using calipers.

Bend the tongue **1** as necessary to bring the height **A** to this value.

Float height <b>A</b>	20.5 ± 1.0 mm
-----------------------	---------------

09900-20102	Vernier calipers
-------------	------------------

### NOTE:

When measuring float height, be sure to remove the gasket.

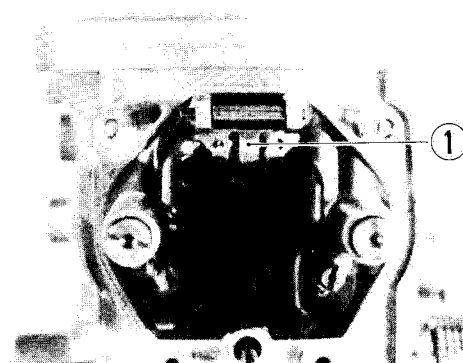
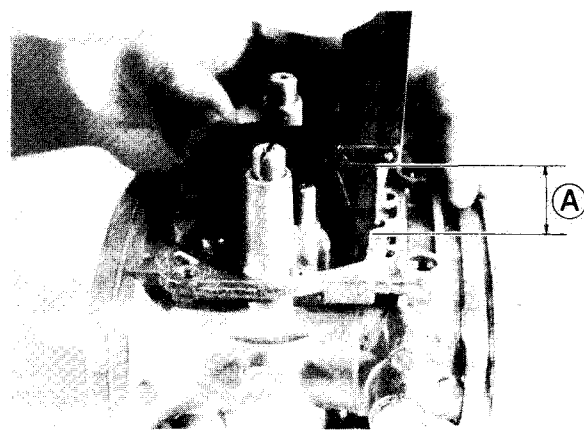

## REASSEMBLY

Reassemble the carburetor, in the reverse order of disassembly.

Pay attention to the following points.

- Apply grease to the throttle valve shaft oil seal.

### NOTE:

Face the oil seal groove outwards.

- While turning the throttle valve shaft, place the throttle valve in the groove so that the I.D. number **2** of the throttle valve faces down-side. Tighten the throttle valve securing screws with applying thread lock "1342".

99000-32050	Thread lock "1342"
-------------	--------------------

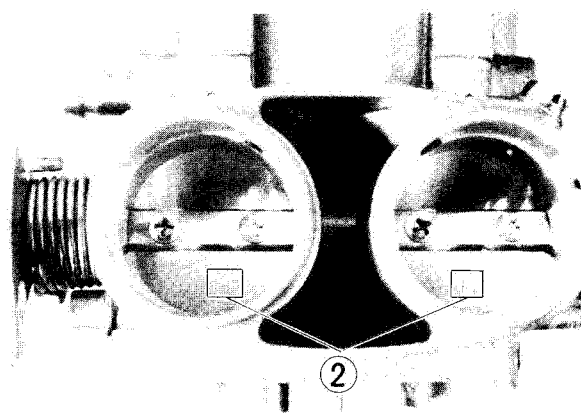

- Align the groove ① of the needle jet with the pin ② and replace it.

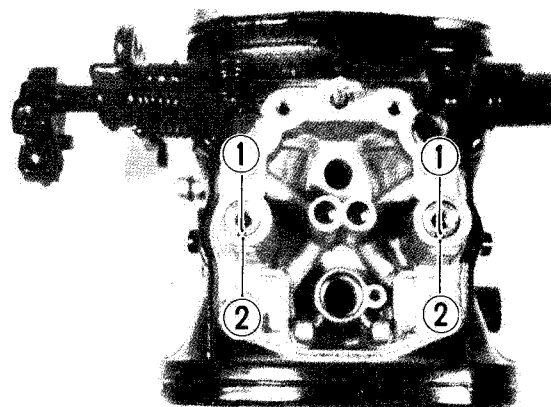

- Engage the two pistons to the piston holder properly.
- Place tongue ③ of diaphragm to the carburetor body properly.



- When engaging the two carburetors, be sure to fix the fuel pipe ④ and position throttle valve control lever ⑤ correctly.

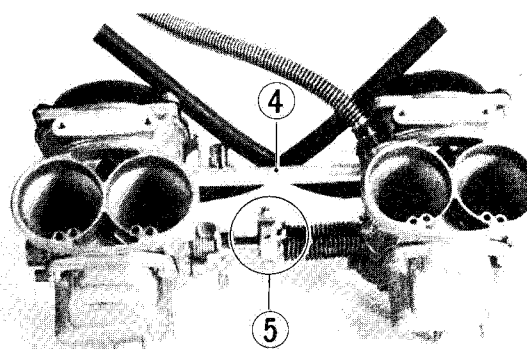

- Apply thread lock "1342" to the upper and lower plate screws.

99000-32050

Thread lock "1342"



- Set each throttle valve in such a way that its top end **B** meets the foremost bypass **A**. This is accomplished by turning throttle valve stop screw **1** and balance screw **2**.

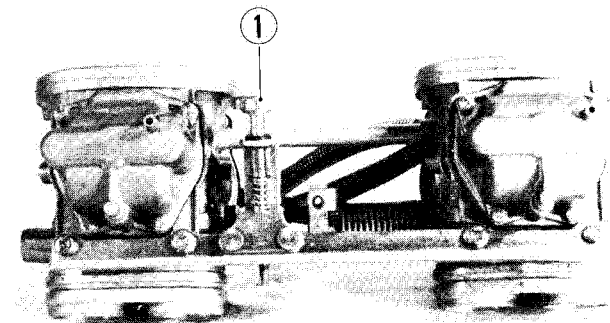
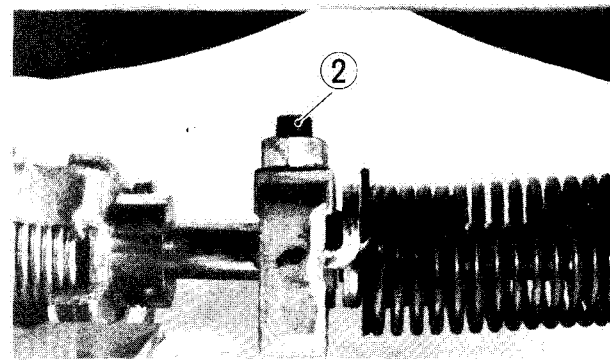
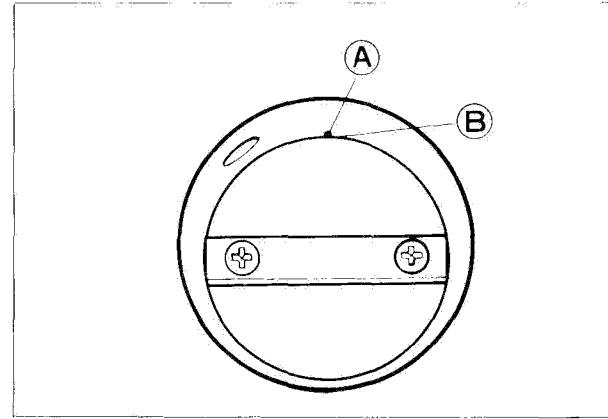

### FUEL LEVEL INSPECTION

- Remove the carburetor drain plug **1** and install the fuel level gauge.

09913-14541	Fuel level gauge
-------------	------------------

- Run the engine at the idling speed (1 200 – 1 400 r/min), and measure the distance of the fuel level gauge with the middle line of the level gauge aligned with the mating surface of float bowl. Fuel level should be within the specified range.

Distance	$9.0 \pm 0.5$ mm
----------	------------------

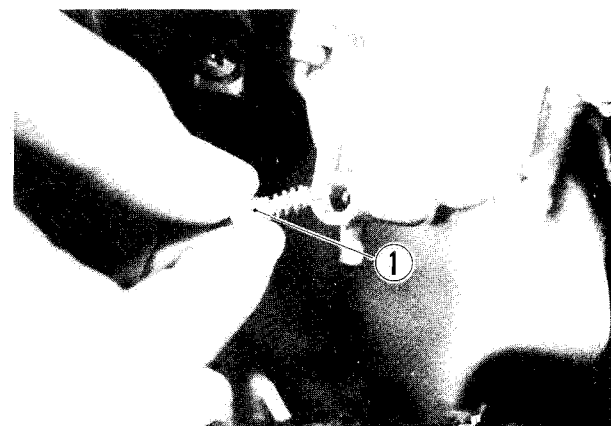

## BALANCING CARBURETORS

The two carburetors must be balanced after disassembling the engine or the carburetors. As the first step, calibrate the carburetor balancer gauge, as follows:

09913-13121	Carburetor balancer
09915-94511	Adapter

- Start up the engine and run it in idling condition for warming up.
- Stop the warmed-up engine. Remove vacuum inspection screw ① for "R" or "L" carburetor and install adapter ② with gasket.
- Tie one of the four rubber hoses of the balancer gauge to this adapter, and start up the engine, and keep it running at 1 900 r/min by turning throttle stop screw.
- Turn the air screw ③ of the gauge so that the vacuum acting on the tube of that hose will bring the steel ball in the tube to the center line.
- After making sure that the steel ball stays steady at the center line, disconnect the hose from the adapter and connect the next hose to the adapter. Turn air screw to bring the other steel ball to the center line.

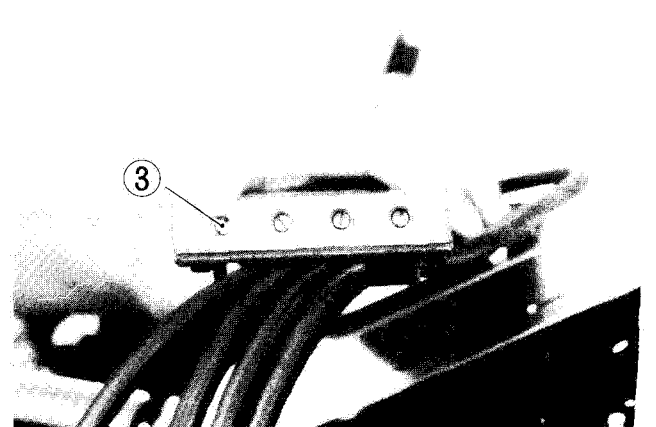
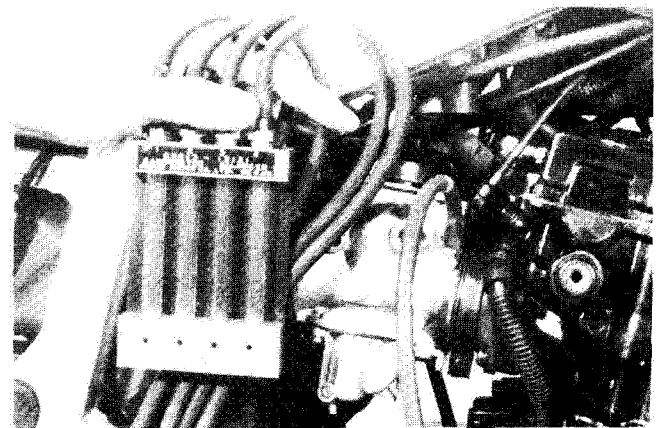
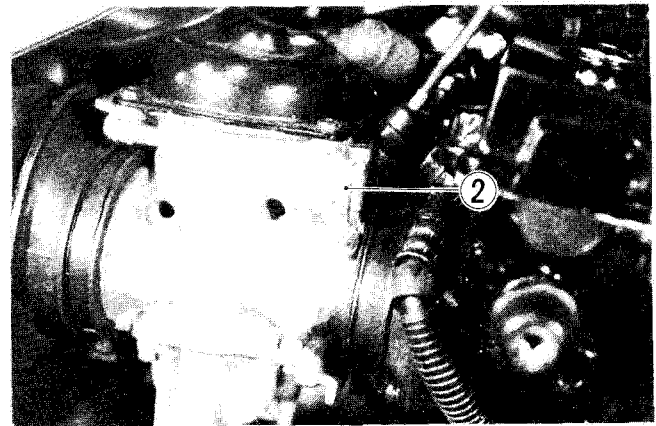
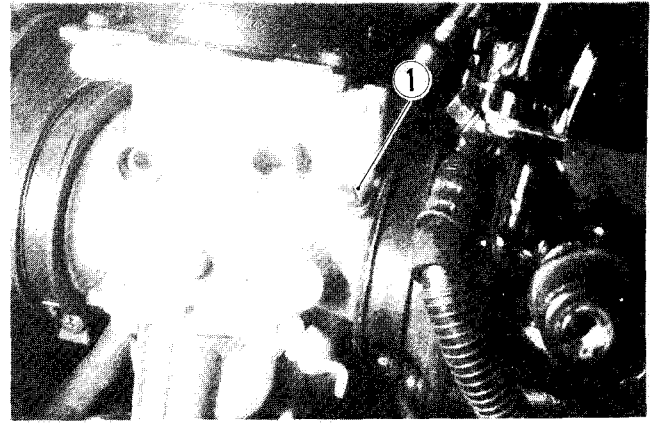

- Remove the vacuum inspection screw for the other carburetor, and install the other adapter.
- Have the two hoses, mentioned above, connected to the two, "R" and "L", adapters. Run the engine at steady 1 900 r/min and, under this running condition, see if the two steel balls stay equally at the center level line, as they should, to signify that the two carburetors, "R" and "L", are in balance: if not, loosen lock nut and turn throttle balance screw ① to adjust the throttle valve setting in "L" carburetor to bring its steel ball to the center level line.

Turning the balance screw ① will tend to change engine speed; if any change is noted, restore the speed to 1 750 r/min by turning the throttle stop screw ②.

09913-14911	Throttle valve adjust wrench
-------------	------------------------------

- After balancing the carburetors, set its speed between 1 200 and 1 400 r/min by turning the throttle stop screw.
- Install the gasket to the vacuum inspection screw.

**NOTE:**

When balancing the carburetors, remove the fuel tank and fuel should be supplied by a separate fuel tank and be sure to plug the fuel cock vacuum line.

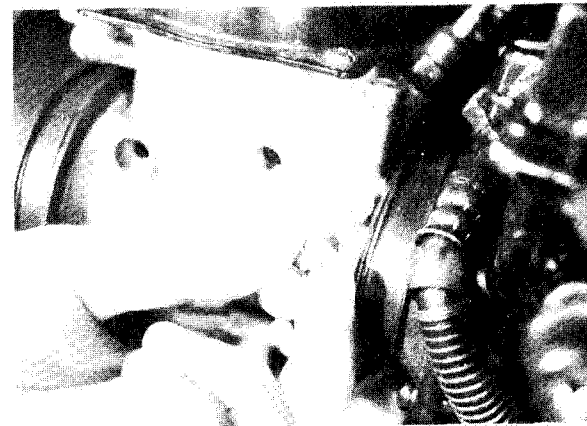
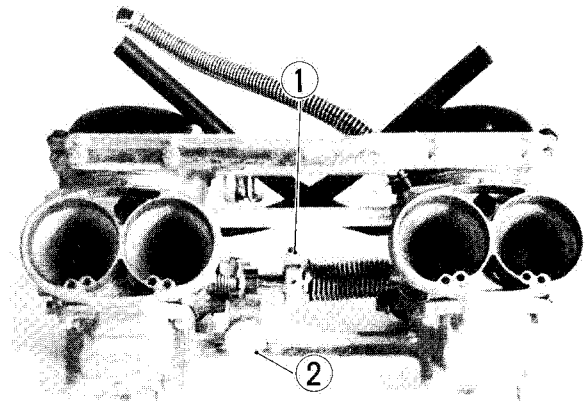
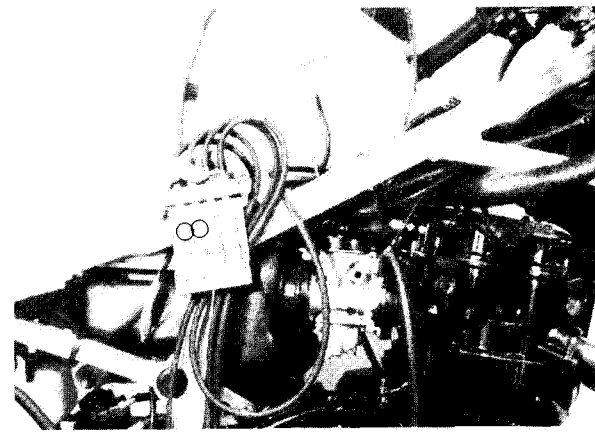

## LUBRICATION SYSTEM

### OIL PRESSURE

Check the oil level in the inspection window and check the oil pressure in the following manner.

- Install the oil pressure gauge ① in the position shown in the figure.
- Warm up the engine as follows:  
Summer 10 min. at 2 000 r/min.  
Winter 20 min. at 2 000 r/min.
- After warming up operation, increase the engine speed to 3 000 r/min, and read the oil pressure gauge.
- The oil pump pressure is specified below:

### OIL PRESSURE SPECIFICATION

Above 2.5 kg/cm<sup>2</sup>,  
Below 5.5 kg/cm<sup>2</sup> at 3 000 r/min  
Oil temp. at 60°C

09915-74510	Oil pressure gauge
09915-77330	Gauge ( 0 – 10 kg/cm <sup>2</sup> )

### OIL SUMP FILTER

At the same time wash the oil pan. Check to be sure that the strainer screen is free from any sign of rupture and wash the strainer clean periodically. When installing oil sump filter, be sure to face the oil inlet to the front.

#### CAUTION:

Replace oil pan gasket with new one to prevent oil leakage.

### OIL LEVEL SWITCH

When draining oil from the engine, check that the oil level lamp turns ON while turning the ignition switch ON.

If the indicator lamp does not light, remove and check the oil level switch.

Using the pocket tester check the continuity when placing the oil level switch upside down. If continuity is found, oil level switch is in good condition.

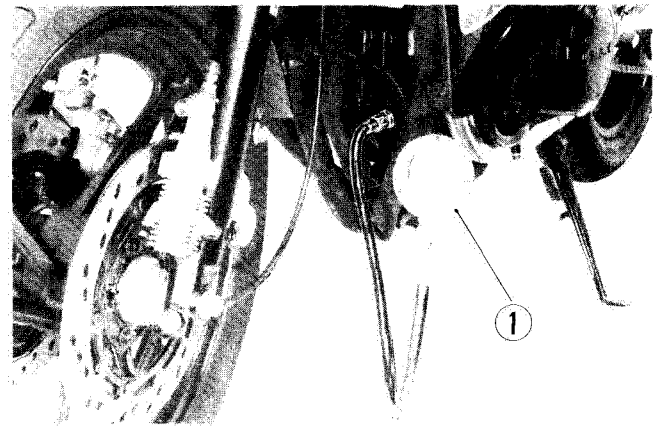

#### CAUTION:

The recommended engine oil is, API classification SE or SF, 10W-40 motor oil.

If the pressure is too low, it means that the oil pump is internally worn or otherwise defective and the complete oil pump unit needs to be replaced.

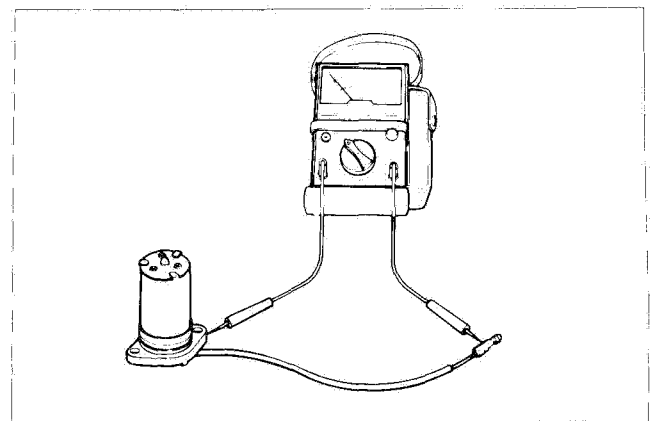
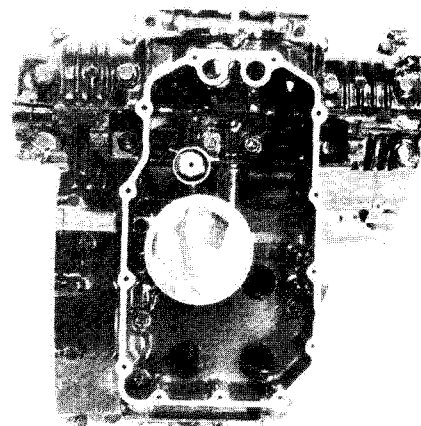

**LUBRICATION SYSTEM CHART**

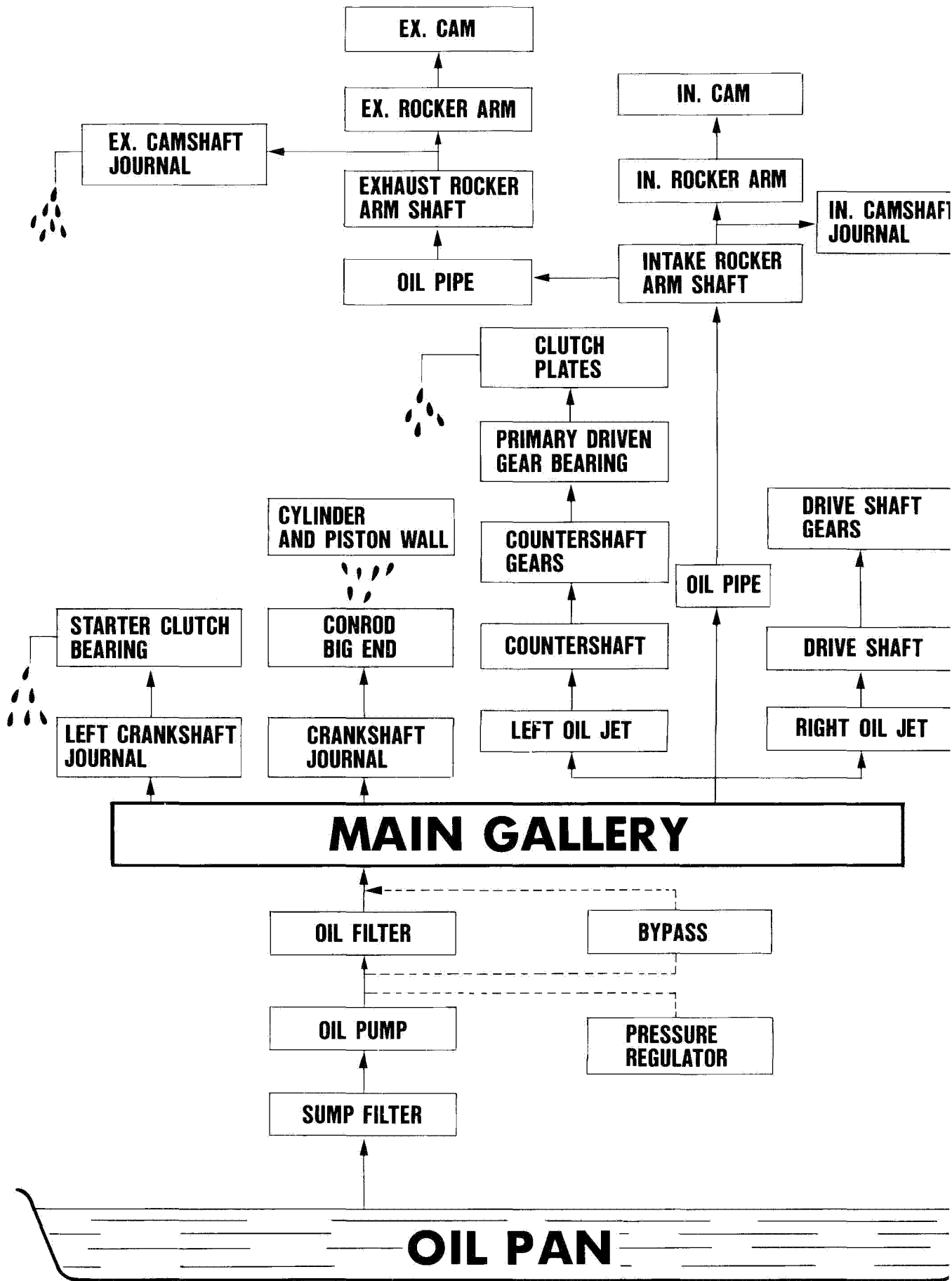



# COOLING SYSTEM

## CONTENTS

<b>COOLING SYSTEM</b> .....	<b>5- 1</b>
<b>RADIATOR AND WATER HOSES</b> .....	<b>5- 4</b>
<b>THERMOSTAT</b> .....	<b>5- 5</b>
<b>WATER PUMP</b> .....	<b>5- 7</b>
<b>THERMO-SWITCH AND FAN MOTOR RELAY</b> .....	<b>5-11</b>
<b>ENGINE THERMO SWITCH</b> .....	<b>5-12</b>
<b>FAN MOTOR RELAY</b> .....	<b>5-12</b>
<b>FAN MOTOR</b> .....	<b>5-13</b>
<b>WATER TEMPERATURE METER AND TEMPERATURE GAUGE</b> .....	<b>5-13</b>

## COOLING SYSTEM

### DESCRIPTION

The engine is cooled by coolant set in forced recirculation through jackets formed in the cylinder and head and through the radiator. For the water pump, a high-capacity centrifugal pump is used. For the radiator, tube-and-fin type aluminum in material, and is characterized by lightness in weight and good heat dissipation.

The thermostat is of wax pellet type, complete with a valve as the means of temperature-dependent control over the flow of water through the radiator. The valve is actuated by the temperature-sensitive wax contained in the pellet.

Referring to the following illustration, the thermostat is in closed condition, so that water recirculates through the route comprising pump, engine, by-pass holes of the thermostat and radiator in the regulated condition.

As the coolant temperature rises to  $75^{\circ}\text{C}$  and the thermostat valve unseats the normal water flow is established. At about  $90^{\circ}\text{C}$  of rising coolant temperature, the thermostat becomes completely open and most of heat is released to the atmosphere through the radiator core.

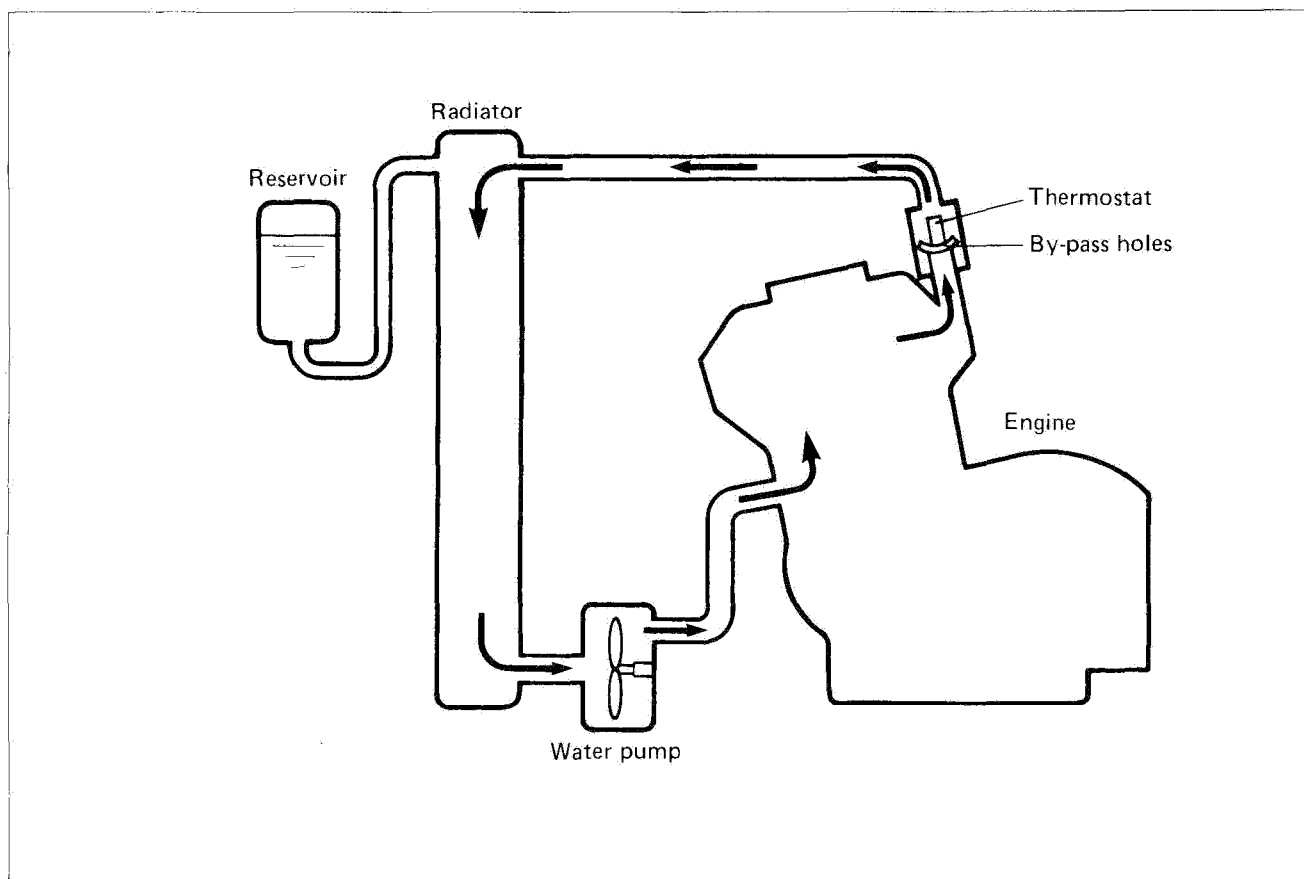

As shown in the following illustration, when the crankshaft turns and power is transmitted to the oil pump through the primary drive and driven gears. When the oil pump turns, the water pump also turns at the same speed as the oil pump shaft is engaged with the water pump shaft.

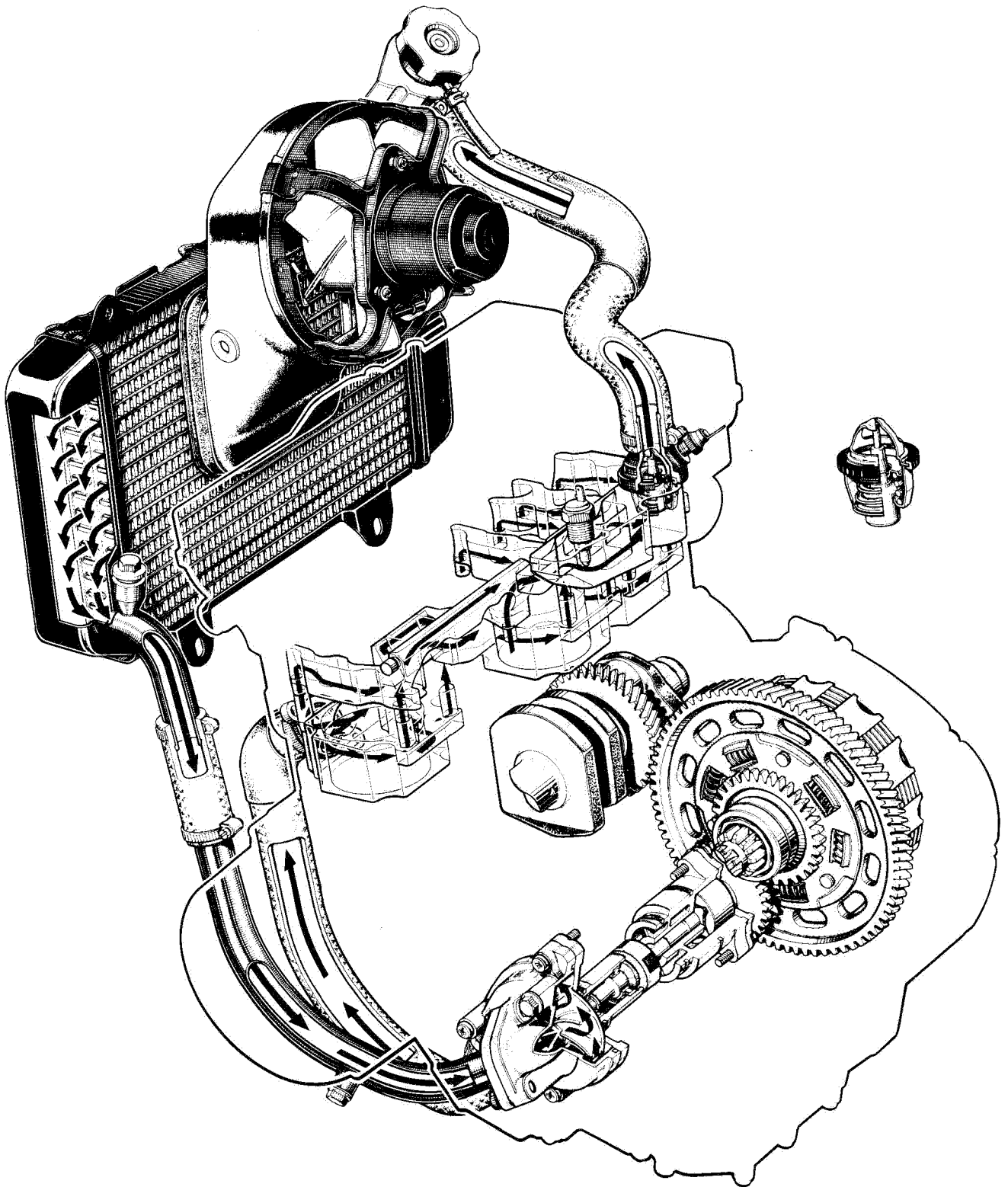

...of engine failure, the cooling system is  
 will provide excellent heat protection, and will  
 If the motorcycle is to be exposed to temperatures  
 below  $-31^{\circ}\text{C}$  ( $-24^{\circ}\text{F}$ ), this mixing ratio should be  
 increased up to 55% or 60% according to the Fig. 2.

**NOTE:**  
 Also included in the cooling solution at the  
 time of manufacture is bar's leak material to  
 help ensure protection against coolant leakage.

**NOTE:**  
 The characteristics of different anti-freezes  
 vary. Read the label to know the protection  
 you will have.

**CAUTION:**  
 Do not put in more than 60% anti-freeze or  
 less than 50%. Do not mix different brands of  
 anti-freeze.

**ANTI-LEAKAGE MATERIAL**

The anti-freeze is characterized by very high values  
 of permeability and leakage accident of the cooling  
 system is highly likely. The anti-leakage substance  
 is used to prevent such a possible leakage and every  
 new motorcycle is serviced with "Bar's Leaks".  
 The same material or its equivalent should be filled  
 in the radiator when cooling water is changed.  
 "Bar's Leaks" is available as one of spare parts in  
 solid form. A suitable amount for use is 2 packs  
 per model and in the case of a liquid anti-leakage  
 material available in the market, 30 – 40 ml  
 should be used.

99000-24240	Bar's Leaks
-------------	-------------

**CAUTION:**  
 Anti-leakage material should not be added  
 except the time of the renewal of coolant.

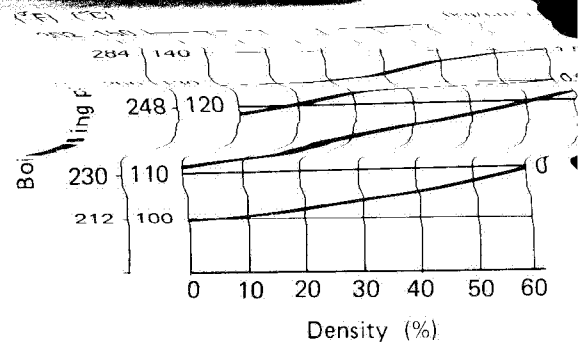

Fig. 1 Coolant density-boiling point curve.

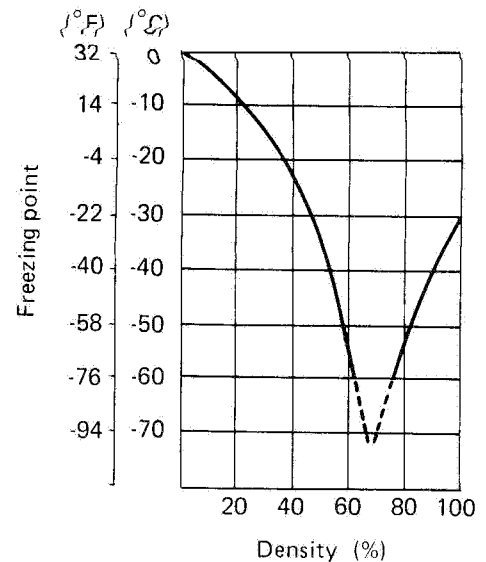

Fig. 2 Coolant density-freezing point curve.

## COOLANT

At the time of manufacture, the cooling system is filled with a 50 : 50 solution of distilled water and anti-freeze/summer coolant. This 50 : 50 mixture will provide excellent heat protection, and will protect the cooling system from freezing at temperatures above  $-31^{\circ}\text{C}$  ( $-24^{\circ}\text{F}$ ).

If the motorcycle is to be exposed to temperatures below  $-31^{\circ}\text{C}$  ( $-24^{\circ}\text{F}$ ), this mixing ratio should be increased up to 55% or 60% according to the Fig. 2.

### NOTE:

Also included in the cooling solution at the time of manufacture is bar's leak material to help ensure protection against coolant leakage.

### NOTE:

The characteristics of different anti-freezes vary. Read the label to know the protection you will have.

### CAUTION:

Do not put in more than 60% anti-freeze or less than 50%. Do not mix different brands of anti-freeze.

### ANTI-LEAKAGE MATERIAL

The anti-freeze is characterized by very high values of permeability and leakage accident of the cooling system is highly likely. The anti-leakage substance is used to prevent such a possible leakage and every new motorcycle is serviced with "Bar's Leaks". The same material or its equivalent should be filled in the radiator when cooling water is changed. "Bar's Leaks" is available as one of spare parts in solid form. A suitable amount for use is 2 packs per model and in the case of a liquid anti-leakage material available in the market, 30 – 40 ml should be used.

99000-24240	Bar's Leaks
-------------	-------------

### CAUTION:

Anti-leakage material should not be added except the time of the renewal of coolant.

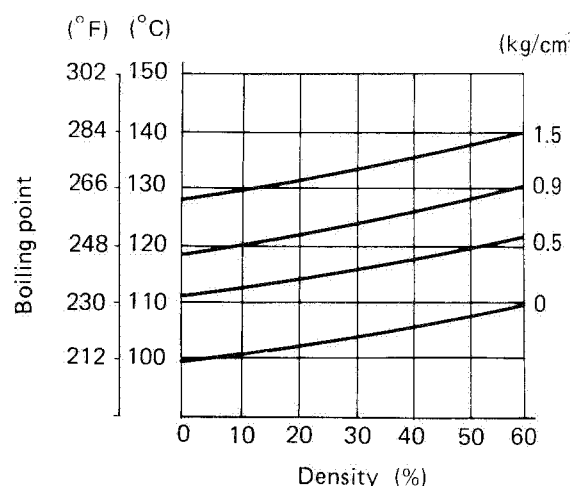

Fig. 1 Coolant density-boiling point curve.

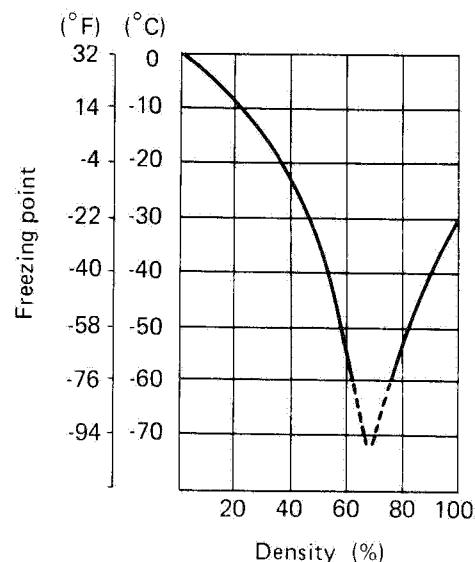

Fig. 2 Coolant density-freezing point curve.

## RADIATOR AND WATER HOSES

### REMOVAL

- Drain the coolant by removing drain plug. (Refer to page 2-11).
- Disconnect water hoses. (Refer to page 3-6).
- Remove the radiator.

### INSPECTION

Before removing the radiator and draining coolant, inspect the following two items.

1. Test the cooling system for tightness by using the radiator tester as follows:  
Remove the radiator cap, and connect the tester to the filler. Give a pressure of about  $1 \text{ kg/cm}^2$  and see if the system holds this pressure for 10 seconds. If the pressure should fall during this 10-second interval, it means that there is a leaking point in the system; in such a case, inspect the entire system and replace the leaking component or part.
2. Test the radiator cap for relieving pressure by using the radiator tester in the following manner: Fit the cap to the tester, as shown, and build up pressure slowly by operating the tester. Make sure that the pressure build-up stops at  $1.1 \pm 0.15 \text{ kg/cm}^2$  and that, with the tester held standstill, the cap is capable of that pressure for at least 10 seconds. Replace the cap if it is found not to satisfy either of these two requirements.

Radiator cup valve release pressure	$110 \pm 15 \text{ kPa}$ ( $1.1 \pm 0.15 \text{ kg/cm}^2$ )
-------------------------------------	--

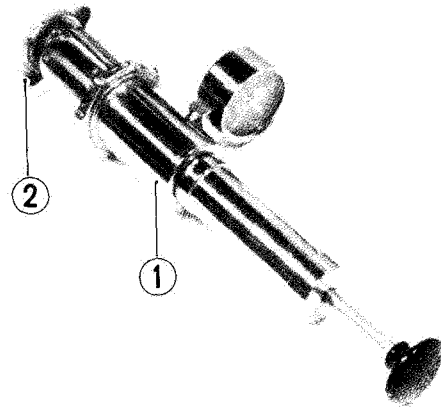
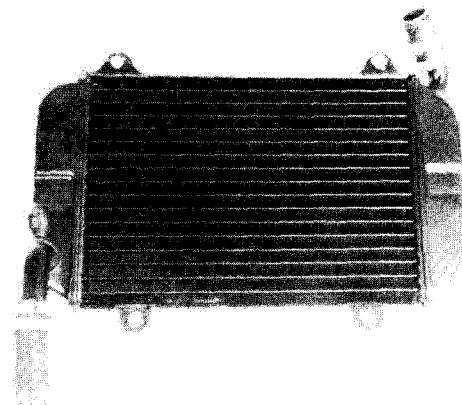

- ① Radiator cap tester
- ② Radiator cap

3. Road dirt or trashes stuck to the fins must be removed. Use of compressed air is recommended for this cleaning. Fins bent down or dented can be repaired by straightening them with the blade of a small screwdriver.
4. Any water hose found in cracked condition or flattened must be replaced.

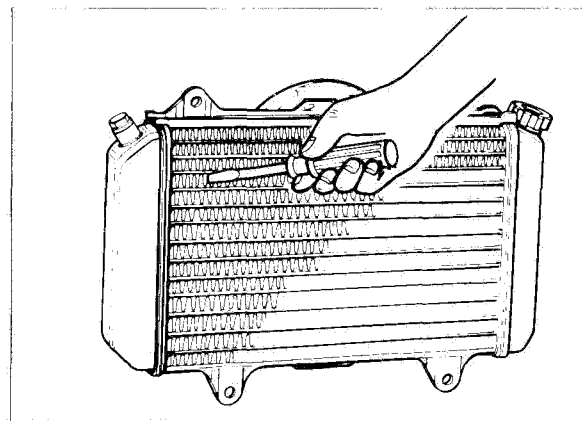

## INSTALLATION

The radiator is to be installed in the reverse order of the removal procedure. After installing the radiator, be sure to add coolant: refer to page 2-11 for refilling information.

## THERMOSTAT REMOVAL

- Drain the coolant.
- Disconnect the radiator inlet hose ① and remove the thermostat cover ②.

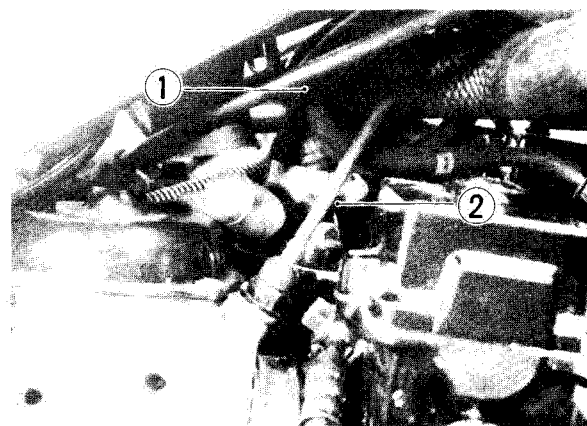

## INSPECTION

Inspect the thermostat pellet for signs of cracking.



Test the thermostat at the bench for control action, in the following manner:

- Pass a fine thread between valve and seat, as shown in the figure.
- Immerse the thermostat in the water contained in the jar, as shown in the figure. Note that the immersed thermostat is in suspension. Heat the water by placing the jar on a stove and observe the rising temperature on the thermometer.
- Read the thermometer just when the thermostat drops to the bottom of the jar. This reading, which is the temperature level at which the thermostat valve begins to open, should be anywhere between 73.5° and 76.5° C.

Thermostat valve opening temperature	75.0 ± 1.5° C
--------------------------------------	---------------

- Keep on heating the water to raise its temperature to and beyond 90° C.
- Just when the water reaches 90° C, the thermostat valve should have lifted by at least 5.9 mm.

Thermostat valve lift	5.9 – 6.1 mm at 90° C
-----------------------	-----------------------

- A thermostat failing to satisfy either of the two requirements (start-to-open temperature and valve lift) must be replaced.

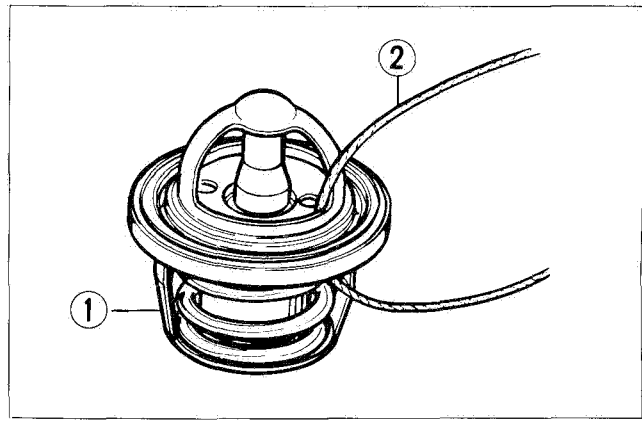

① Thermostat ② Fine thread

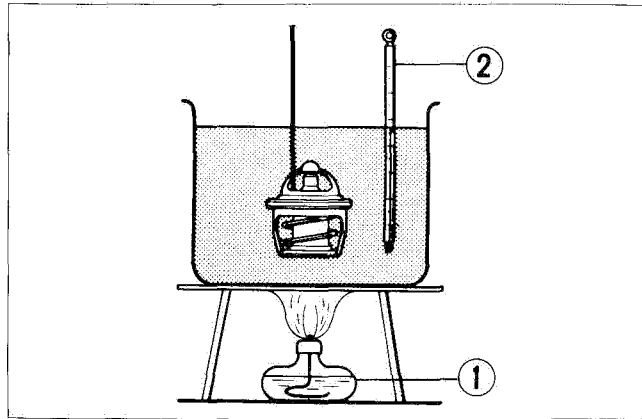

① Stove ② Thermometer

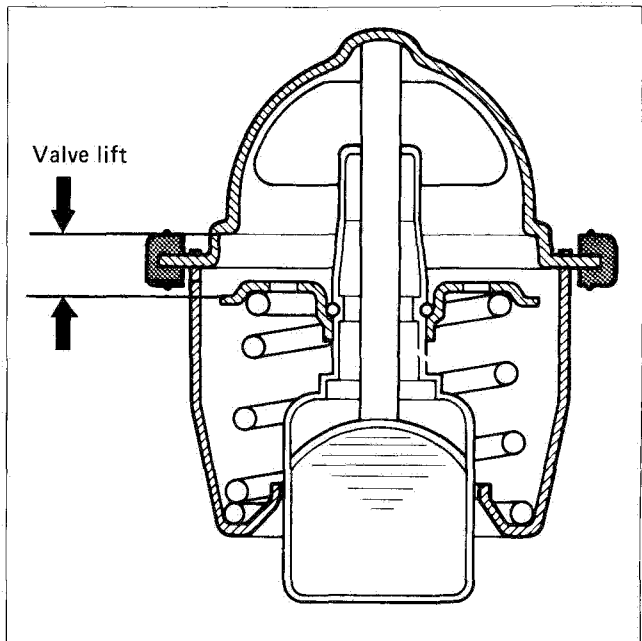

Valve lift





## WATER PUMP

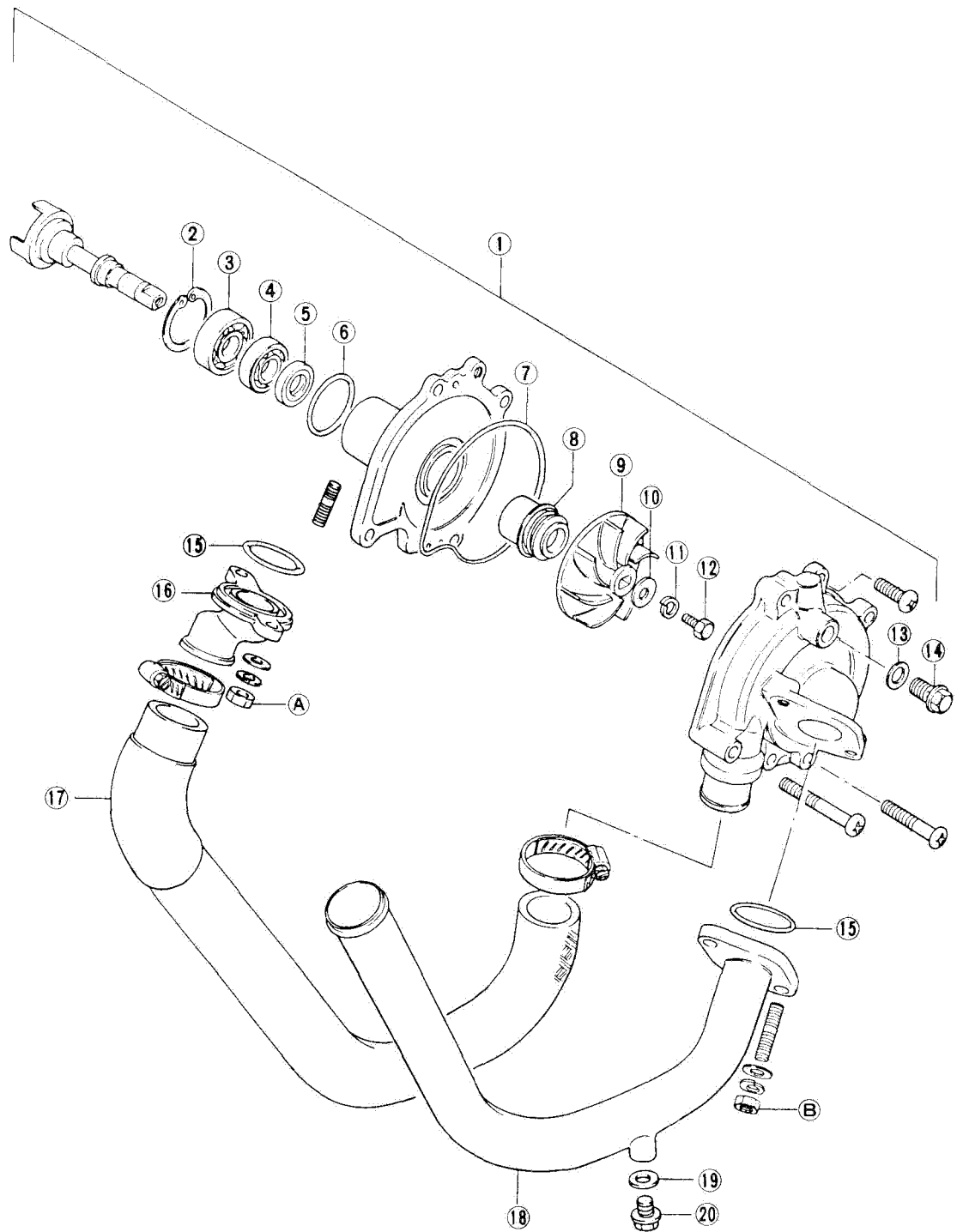

## Tightening torque

Item	N·m	kg·m
⑫	7 - 9	0.7 - 0.9
⑭	10	1.0
Ⓐ	4 - 7	0.4 - 0.7
Ⓑ	4 - 7	0.4 - 0.7
⑳	12 - 16	1.2 - 1.6

- ① Water pump assembly
- ② Circlip
- ③ Bearing
- ④ Bearing
- ⑤ Oil seal
- ⑥ O-ring
- ⑦ O-ring
- ⑧ Mechanical seal
- ⑨ Impeller
- ⑩ Gasket
- ⑪ Lock washer
- ⑫ Bolt
- ⑬ Gasket
- ⑭ Bleeder bolt
- ⑮ O-ring
- ⑯ Water pump outlet connector
- ⑰ Outlet hose
- ⑱ Radiator outlet pipe
- ⑲ Gasket
- ⑳ Drain bolt

## REMOVAL

- Drain the coolant by removing the drain plug.
- Remove the engine sprocket cover.
- Remove the water pump outlet hose ① and radiator outlet pipe ②.
- Remove the water pump.

### CAUTION:

When removing the water pump, do not drop the shaft engagement piece ③ in the engine.

- ③ Shaft engagement piece
- ④ Water pump
- ⑤ Oil pump

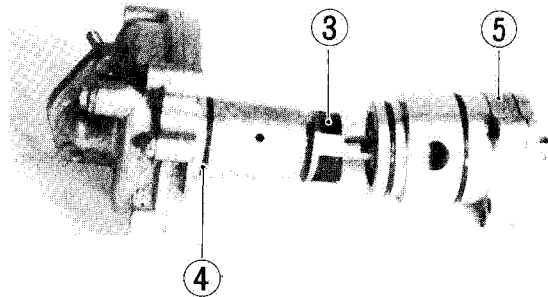
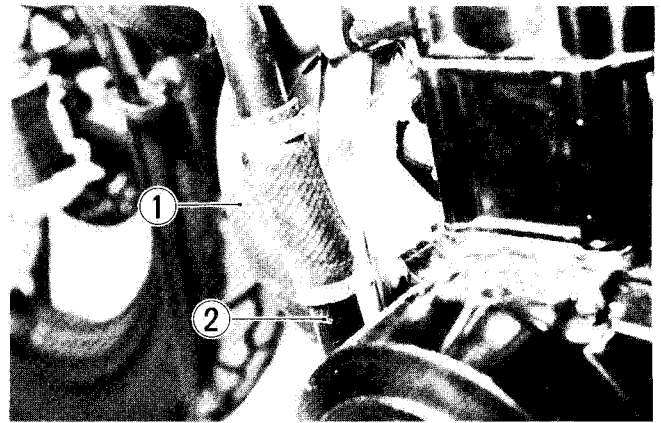

## DISASSEMBLY

- Remove the water pump housing screws.

09900-09003

Impact driver set

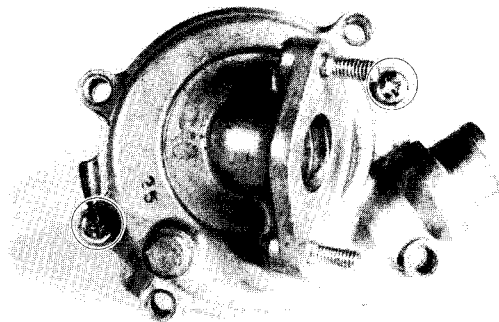

- Remove impeller center bolt while holding the water pump shaft.

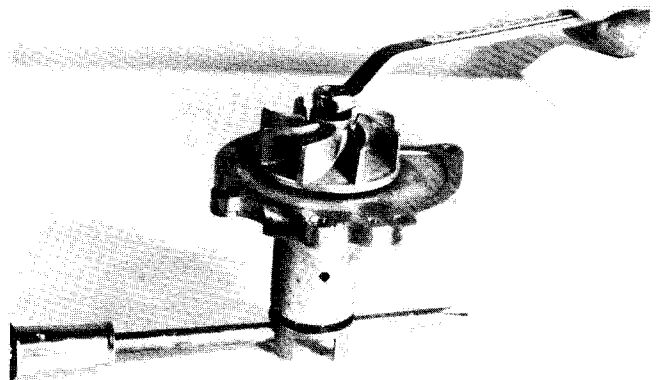

- Remove the water pump shaft from the other side.

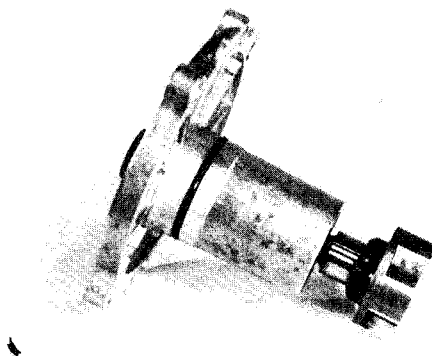

- Using snapping pliers, remove the circlip.

09900-06105	Snapping pliers
-------------	-----------------

- Using the special tools, remove two bearings and oil seal.

09930-30102	Rotor remover slide shaft
09921-20210	Bearing remover

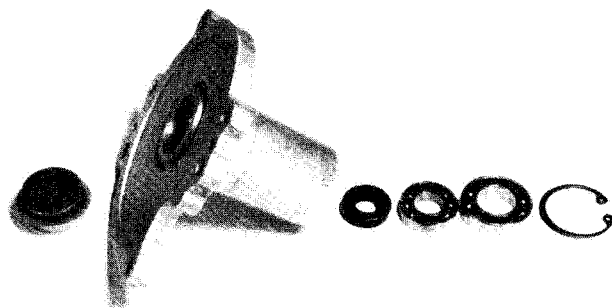
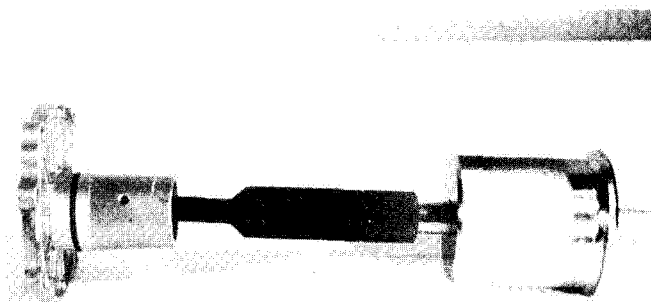
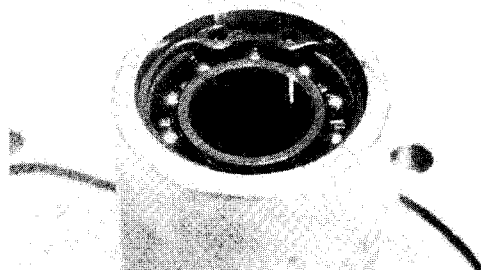

## INSPECTION

- If any sign of oil leakage or water leakage is noted, replace the oil seal or mechanical seal.

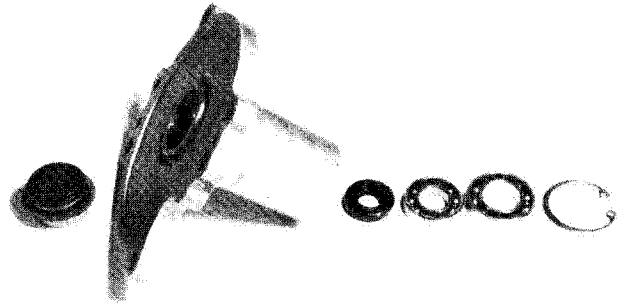

- Turn the impeller and check the bearing play. If abnormal noise occurs or any stickiness is noted, replace the bearing with a new one.

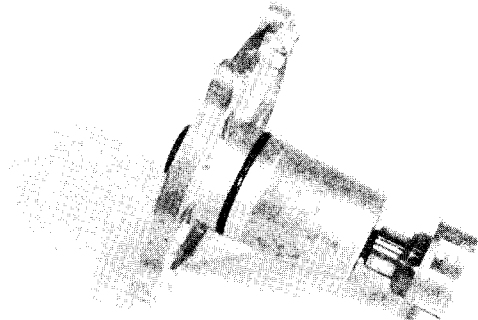

## REASSEMBLY

Reassemble and remount the water pump in the reverse order of disassembly and removal.

- Replace O-rings with new one when reassembling the water pump.

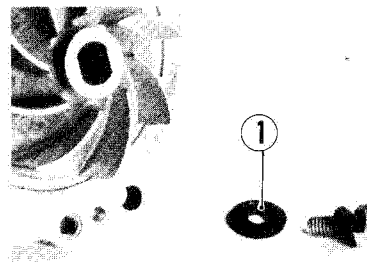

### CAUTION:

Use the new gasket ① for impeller center bolt. When installing the gasket, face the iron side to the spring washer and bolt.

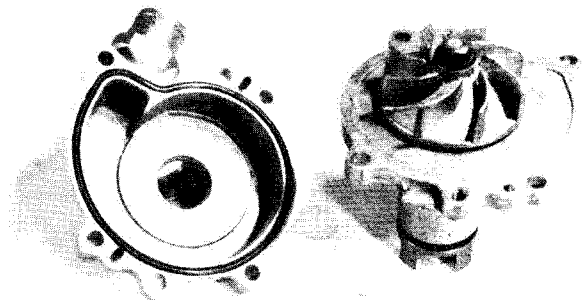

## THERMO-SWITCH AND FAN MOTOR RELAY

The cooling fan, being located behind the radiator, is secured to the radiator by four bolts. The fan drive motor is automatically controlled by the thermo-switch. This switch remains open when the temperature of cooling water is low, but it closes at about 110°C of rising water temperature to set the fan in motion.

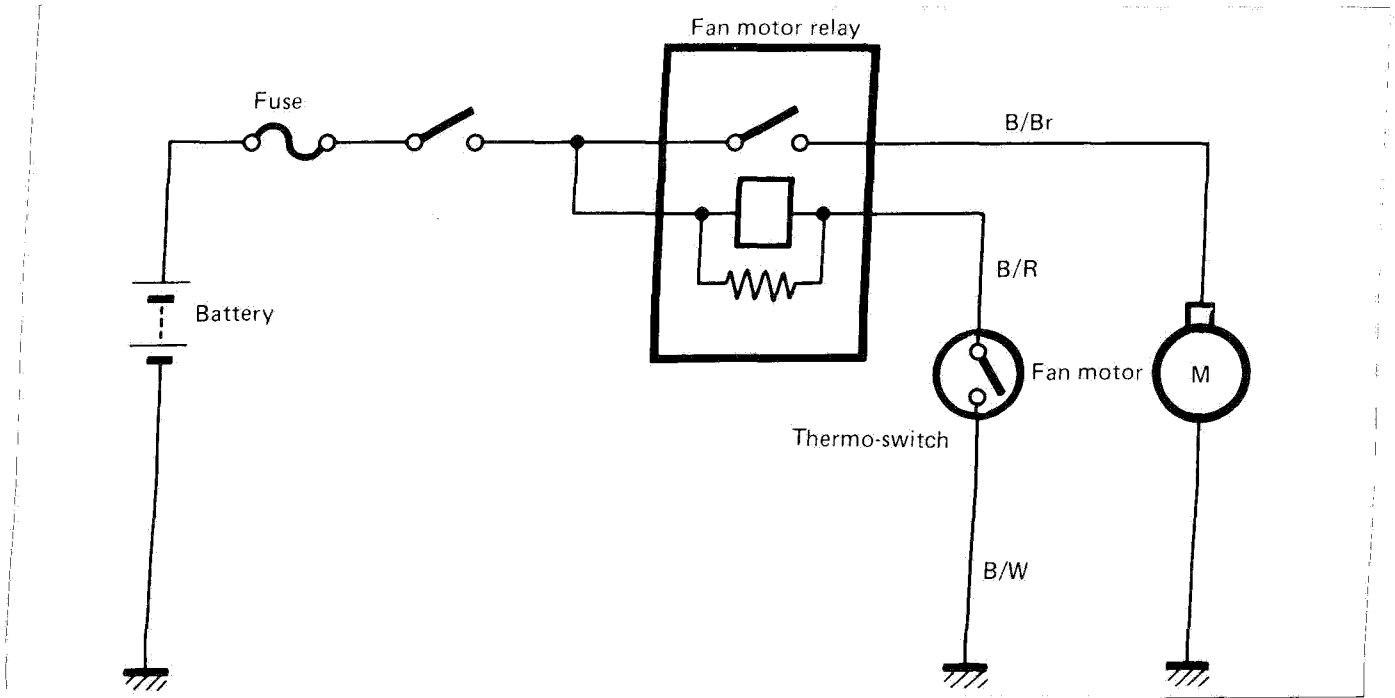

### INSPECTION

Before inspecting the individual parts, check the following items.

- Disconnect the thermo-switch lead wire and connect the jumper lead between lead wire from the main wiring harness and the engine ground.
- When turning the ignition switch ON, electric fan should be in motion. If the electric fan is not turning, proceed the following step.
- Using jumper wire, connect the two terminals of the fan motor relay and turn the ignition switch ON.
- If the electric fan is not turning, inspect the individual parts.

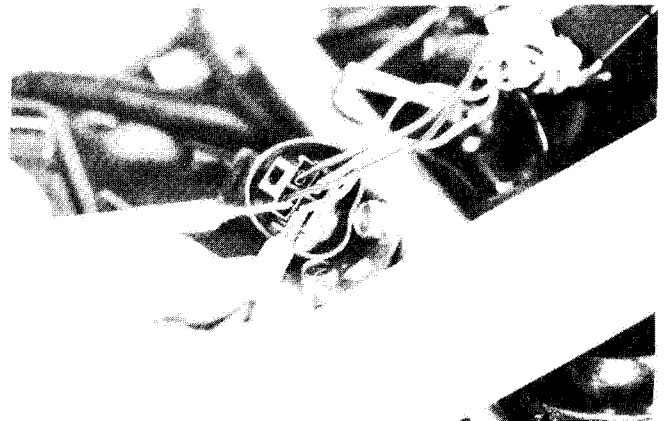
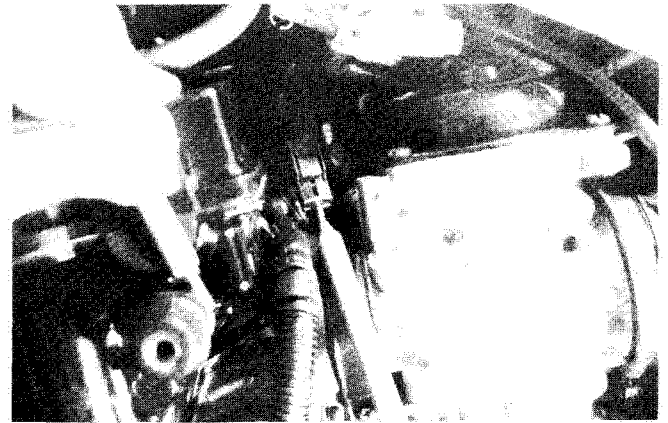

### ENGINE THERMO-SWITCH

- Remove the engine thermo-switch from the cylinder head.
- The thermo-switch must be checked for its temperature-initiated closing action at the specification value of 110°C by testing it at the bench as shown in the figure. Connect the switch to a circuit tester and raise the temperature of the oil in the pan, and read the column thermometer when the switch closes.

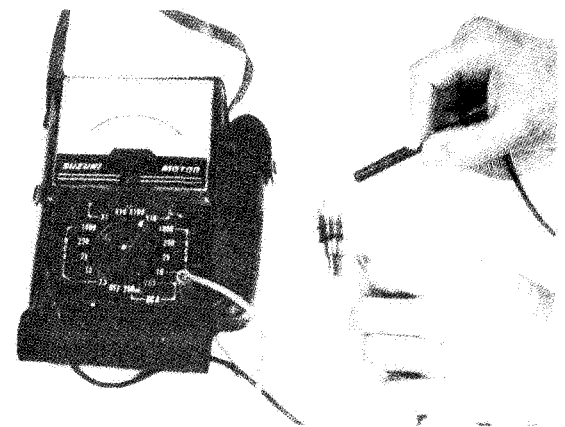

Thermo-switch specification

ON	Approx. 110°C
OFF	Approx. 103°C

- When reinstalling the thermo-switch, apply SUZUKI Bond No.1207B to the thread portion of the switch.

99000-31140	SUZUKI Bond No.1207B
-------------	----------------------

**CAUTION:**

Take special care when handling the thermo-switch. It may cause damage if thermo-switch gets a sharp impact.

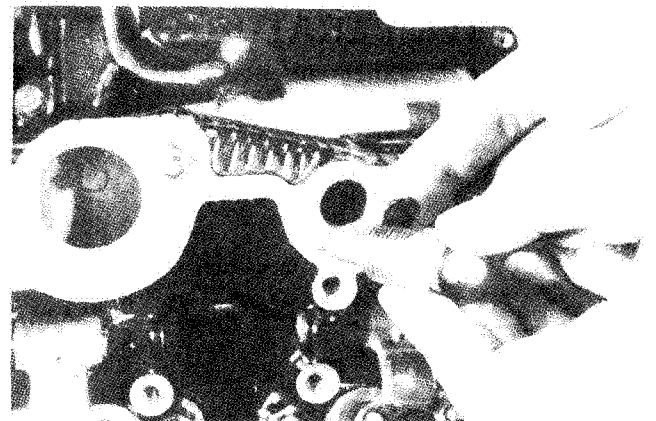

### FAN MOTOR RELAY

- Disconnect the coupler from the fan motor relay.
- Using the pocket tester and check the resistance between (2) and (1).

09900-25002	SUZUKI Pocket Tester
-------------	----------------------

- Check the coil for "Open", "Ground" and ohmic resistance. The coil is in good condition if the resistance is as follows.

Standard resistance	Approx. 70 Ω
---------------------	--------------

- Apply 12 Volts to (1) and (2) terminals, (+) to (1) and (-) to (2), and check the continuity between (3) and (4) with pocket tester. If there is no continuity, replace the fan relay assembly with a new one.

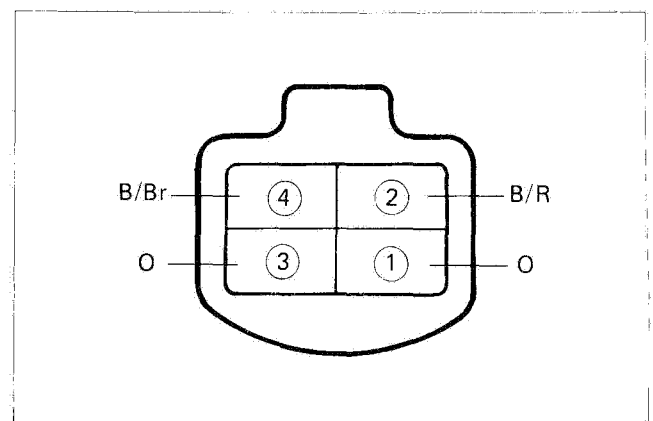
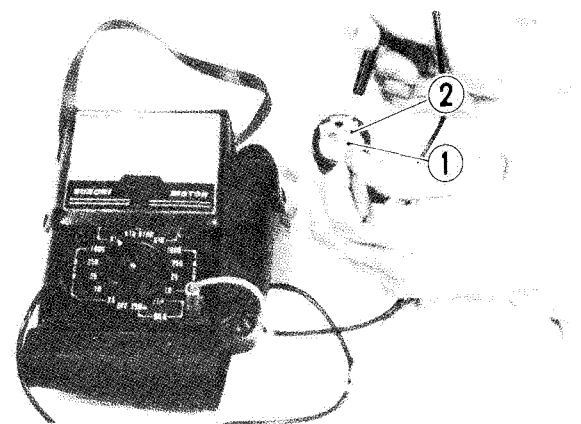

## FAN MOTOR

Test the cooling fan drive motor for load current with a voltmeter and an ammeter connected as shown in the figure. The voltmeter is for making sure that the battery applies 12 volts to the motor. With the motor with electric fan running at full speed, the ammeter should be indicating not more than 4 amperes.

If the fan motor does not turn, replace the motor assembly with a new one.

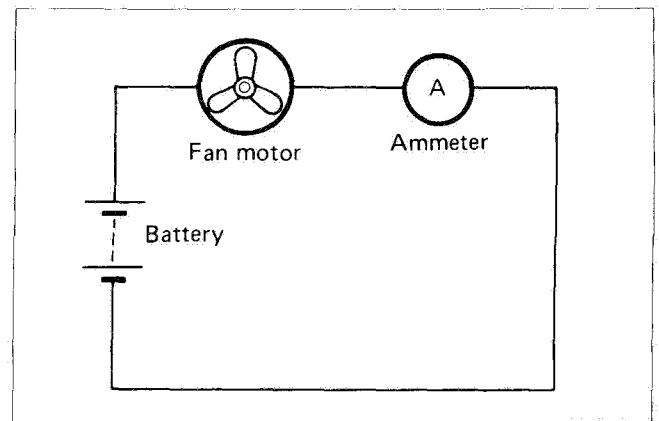

## WATER TEMPERATURE METER AND TEMPERATURE GAUGE

The following circuit diagram shows the electrical wiring for the thermometer. The major components are: temperature gauge in contact with cooling water; and temperature indicator (water temperature meter).

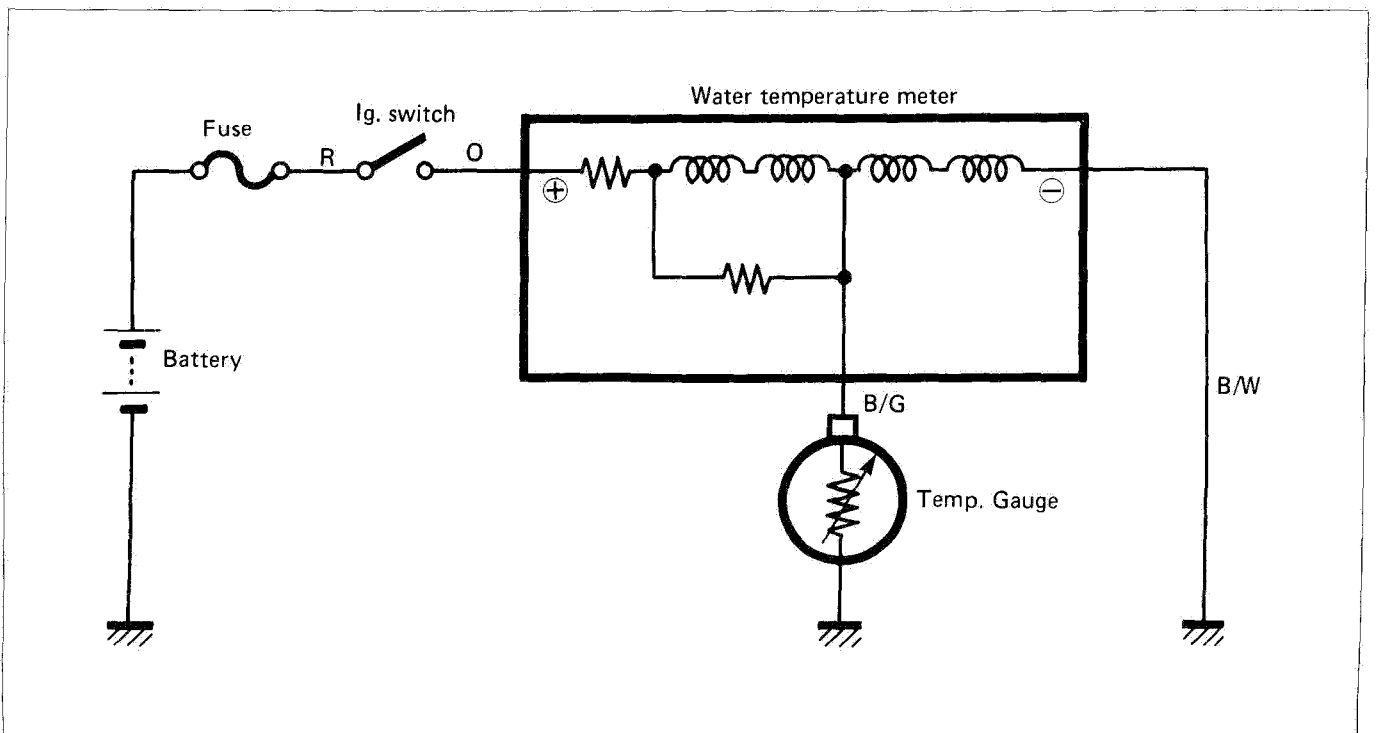

## INSPECTION

Test the temperature gauge sensor at the bench to see if its ohmic value changes, as specified with, temperature. The test is to be run as follows: Connect the temperature gauge to the ohmmeter and place it in the oil contained in a pan, which is placed on a stove; heat the oil to raise its temperature slowly, reading the thermometer placed in the pan and also the ohmmeter. A temperature gauge whose ohmic value does not change in the proportion indicated in the next page must be replaced.

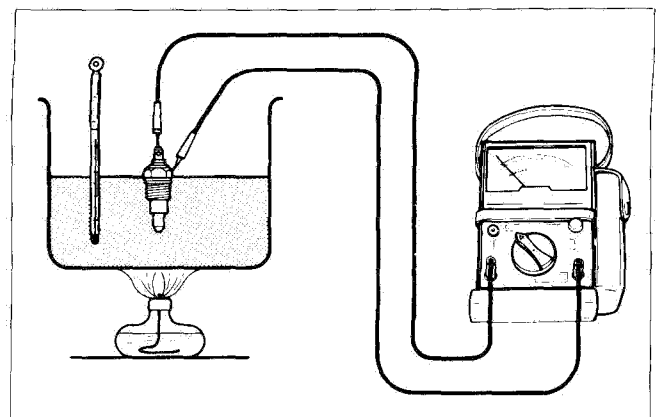

**Temperature gauge specification**

Oil temp. (°C)	Standard resistance ( $\Omega$ )
40	235 – 240
60	100 – 105
80	50 – 55
100	25 – 30

If the resistance noted to show infinity or too much different resistance value, temperature gauge must be replaced.

For inspecting the water temperature meter, refer to page 6-13.

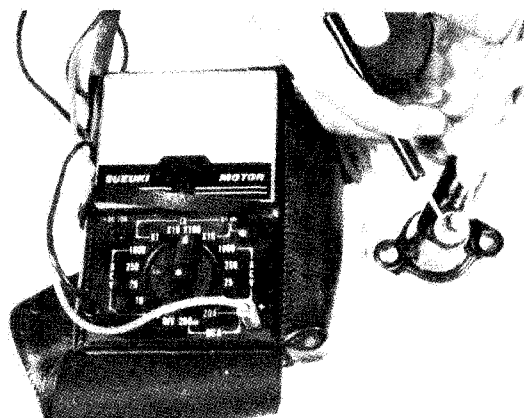
**REASSEMBLY**

Apply SUZUKI Bond No.1207B to the thread portion of the temperature gauge and install it to the thermostat cover.

99000-31140	SUZUKI Bond No.1207B
-------------	----------------------

Tightening torque	12 N·m (1.2 kg·m)
-------------------	----------------------

Tighten the thermostat cover bolt and nut to the specification.

Tightening torque	10 – 15 N·m (1.0 – 1.5 kg·m)
-------------------	---------------------------------

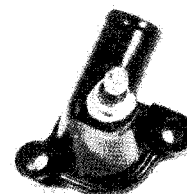



# **ELECTRICAL SYSTEM**

## **CONTENTS**

<b>CHARGING SYSTEM</b> .....	<b>6- 1</b>
<b>IGNITION SYSTEM</b> .....	<b>6- 5</b>
<b>STARTER SYSTEM</b> .....	<b>6- 8</b>
<b>COMBINATION METER</b> .....	<b>6-11</b>
<b>WATER TEMPERATURE METER</b> .....	<b>6-13</b>
<b>LAMPS</b> .....	<b>6-14</b>
<b>SWITCHES</b> .....	<b>6-15</b>
<b>BATTERY</b> .....	<b>6-17</b>

## CHARGING SYSTEM

### DESCRIPTION

The circuit of the charging system is indicated in figure, which is composed of an AC generator, regulator/rectifier unit and battery.

The AC current generated from AC generator is converted by rectifier and is turned into DC current, then it charges the battery.

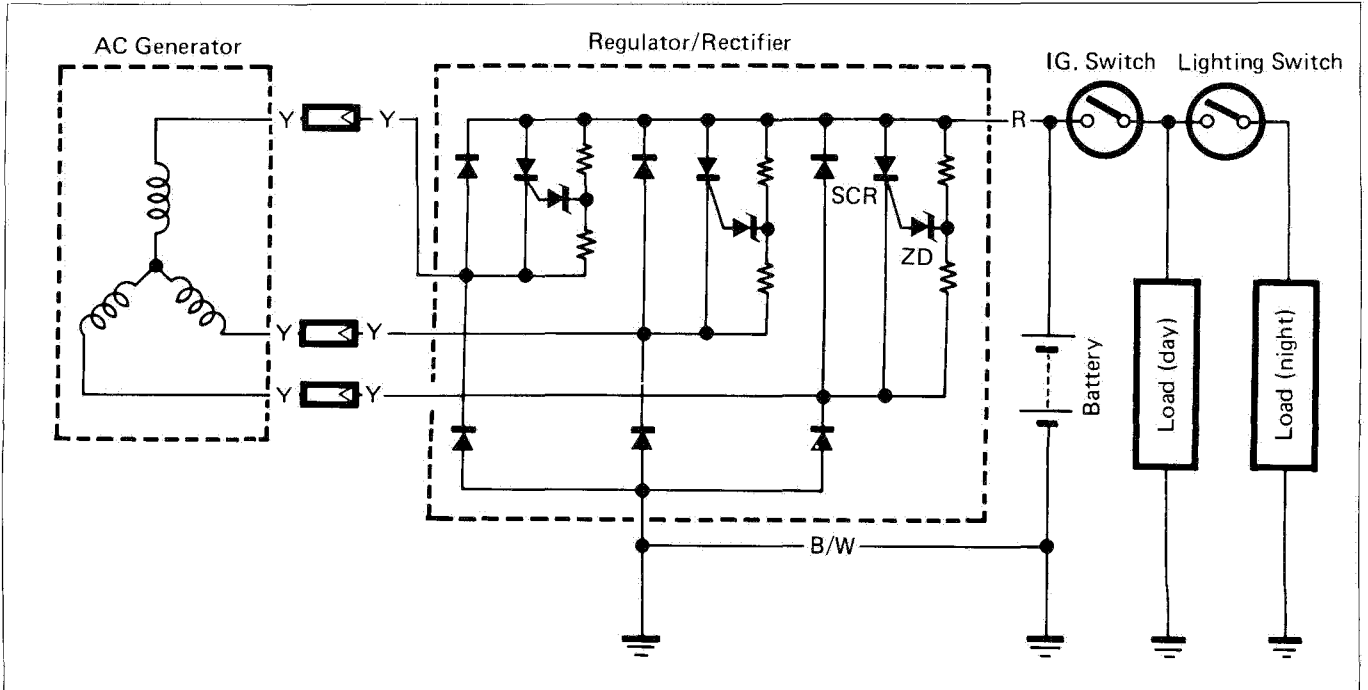

### Function of Regulator

While the engine r/min is low and the generated voltage of AC generator is lower than the adjusted voltage of regulator, the regulator does not function, incidentally the generated current charges the battery directly.

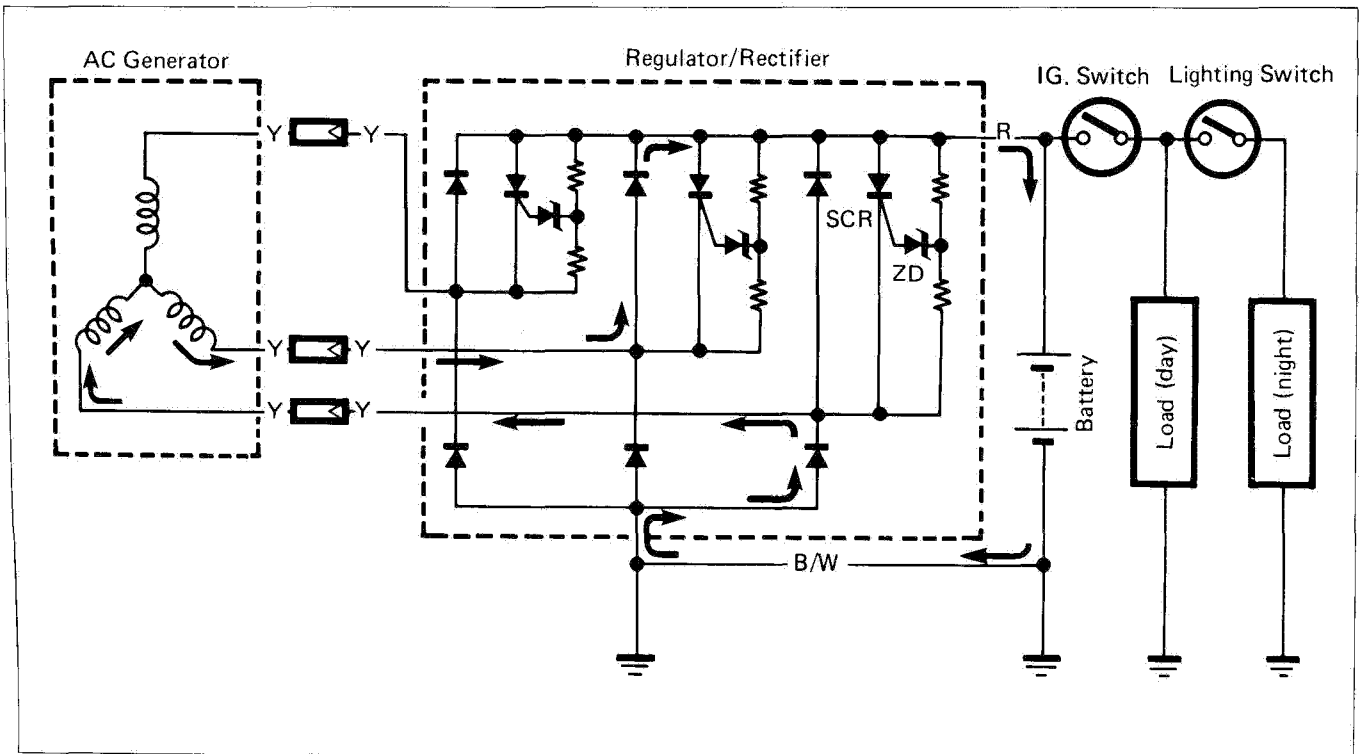

When the engine r/min becomes higher, the generated voltage of AC generator also becomes higher and the voltage between points **A** and **B** of regulator becomes high accordingly, and when it reaches the adjusted voltage of regulator, ZD (Zener diode) sends signal to the gate of SCR (Thyristor). Then the SCR becomes conductive to the direction from point **C** to point **D**. Namely at the state of this, the current generated from the AC generator gets through SCR without charging the battery and returns to AC generator again. At the end of this state, since the AC current generated from AC generator flows into the point **D**, reverse current tends to flow to SCR, then the circuit of SCR turns to OFF mode and begins to charge the battery again. Thus these repetitions maintain charging voltage to the battery constant and protect it from over-charging.

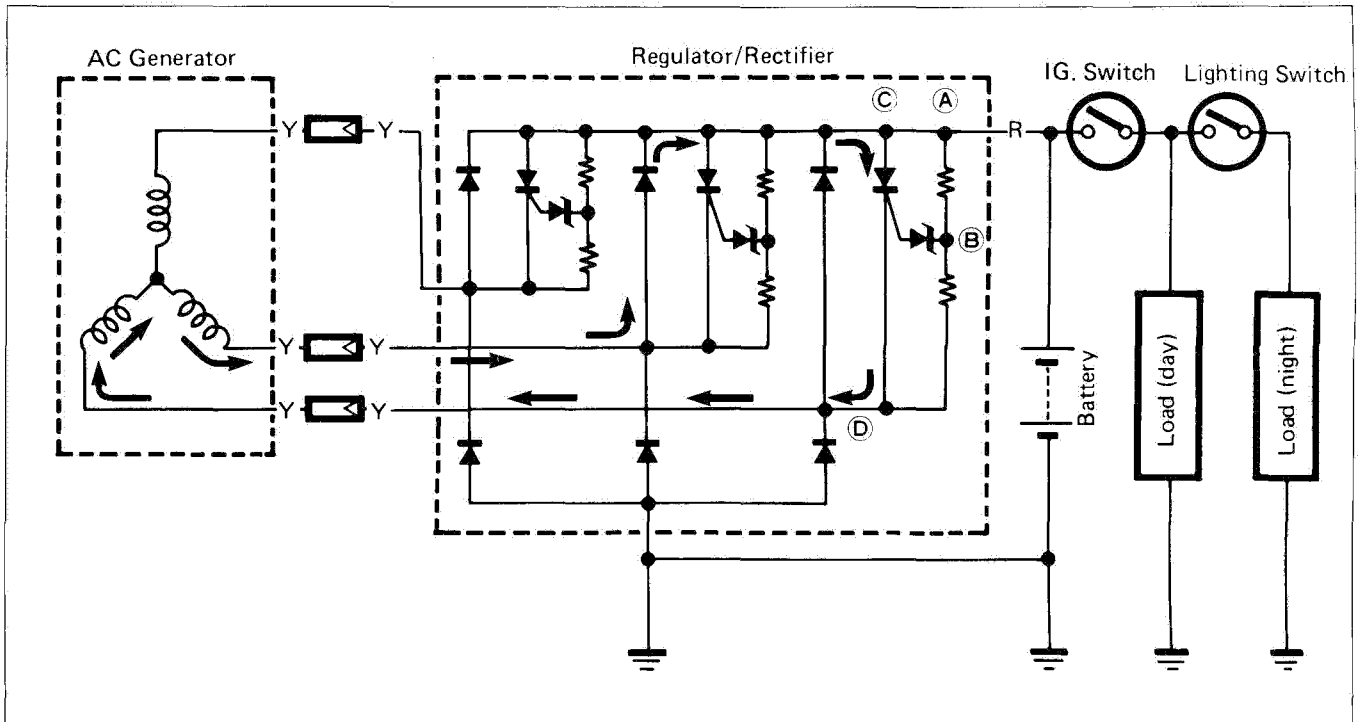

**INSPECTION****CHARGING OUTPUT CHECK**

- Remove the seat.
- Start the engine and keep it running at 5 000 r/min with dimmer switch turned HI position.
- Using the pocket tester, measure the DC voltage between the battery terminal  $\oplus$  and  $\ominus$ .
- If the tester reads under 13.5V or over 15.5V, check the AC generator no-load performance and regulator/rectifier.

**NOTE:**

When making this test, be sure that the battery is fully-charged condition.

STD charging output	13.5 – 15.5V (DC) at 5,000 r/min.
---------------------	-----------------------------------

09900-25002	Pocket tester
-------------	---------------

**AC GENERATOR NO-LOAD PERFORMANCE**

- Remove the left frame cover.
- Disconnect the couplers from the regulator/rectifier.
- Start the engine and keep it running at 5 000 r/min.
- Using the pocket tester, measure the AC voltage between the three yellow lead wires.
- If the tester reads under 80V, the AC generator is faulty.

STD No-load performance	More than 80V (AC) at 5,000 r/min.
-------------------------	------------------------------------

09900-25002	Pocket tester
-------------	---------------

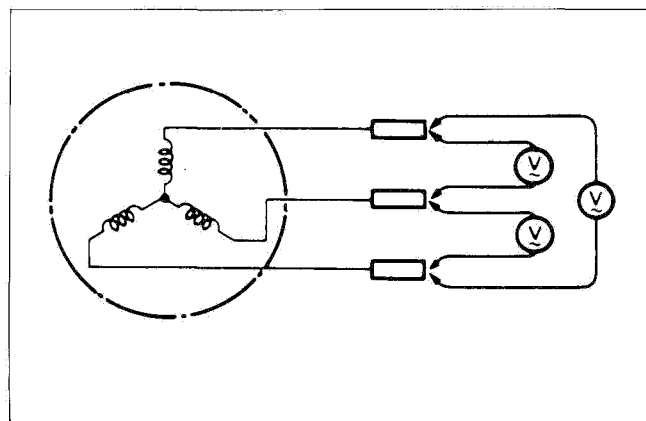
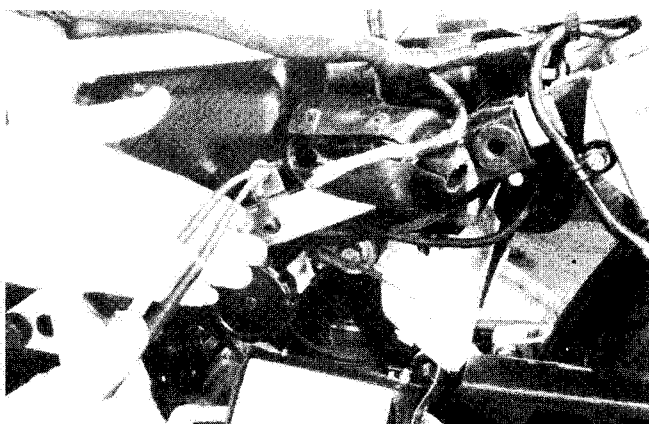
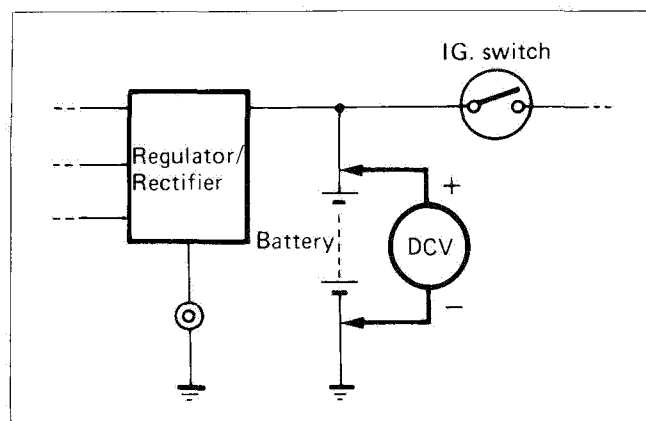
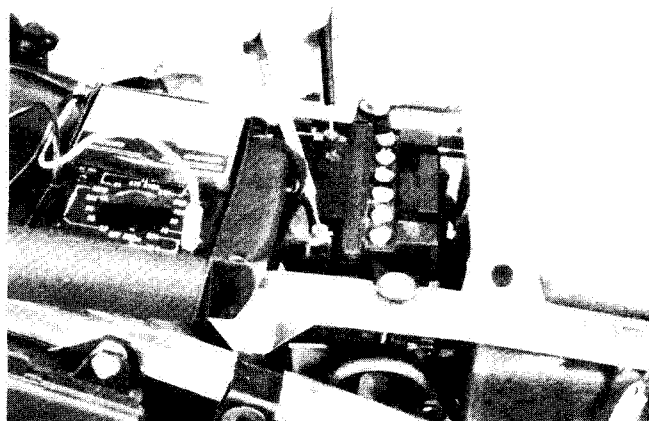

**REGULATOR/RECTIFIER**

- Remove the regulator/rectifier from the brace.
- Using the pocket tester (X k $\Omega$  range), measure the resistance between the lead wires in the following table.
- If the resistance checked is incorrect, replace the regulator/rectifier.

09900-25002	Pocket tester
-------------	---------------

Unit: k $\Omega$ 

⊖ Probe of tester	⊕ Probe of tester				
	R	Y	Y	Y	B/W
R		OFF	OFF	OFF	OFF
Y	2-4		OFF	OFF	OFF
Y	2-4	OFF		OFF	OFF
Y	2-4	OFF	OFF		OFF
B/W	6-15	2-4	2-4	2-4	

**CAUTION:**

As transistors, capacitors, Zener diodes, etc. are used inside this unit, the resistance values will differ when an ohmmeter other than the Suzuki pocket tester is used.

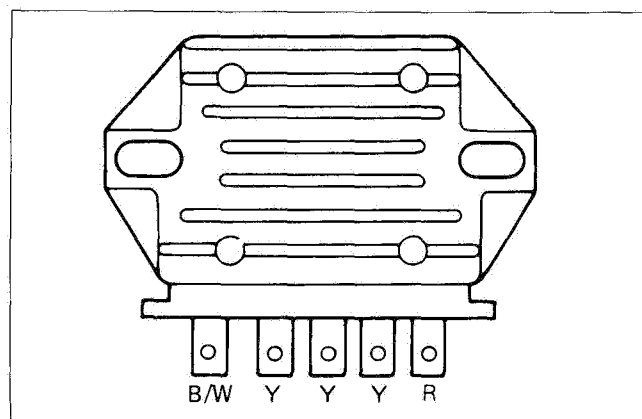

## IGNITION SYSTEM

### DESCRIPTION

The fully transistorized ignition system consists of a signal generator, transistor ignitor, ignition coils, and spark plugs. The signal generators comprised of one rotor and two pick-up coils.

The signal generator is mounted at the right end of the crankshaft. The output of the signal generator goes to the transistor ignitor unit, where it turns ON and OFF the transistor alternately. As the transistor is turned ON and OFF, the current passing through the primary windings of the ignition coil is also turned OFF and ON accordingly, thus it induces the secondary current in the ignition coil secondary windings and produce the spark between spark plug gaps.

Ignition cut-off circuit is incorporated in the ignitor unit to prevent over-running engine. If engine r/min. reaches 11,500 r/min., this circuit cuts off the ignition primary current for Nos. 1 and 4 spark plugs, and ignition starts again if r/min. falls about 20 r/min.

#### CAUTION:

Engine will be run over 11,500 r/min. without load even if the ignition cut-off circuit is effective, and it may cause engine damage. Do not run the engine without load over 11,500 r/min. at anytime.

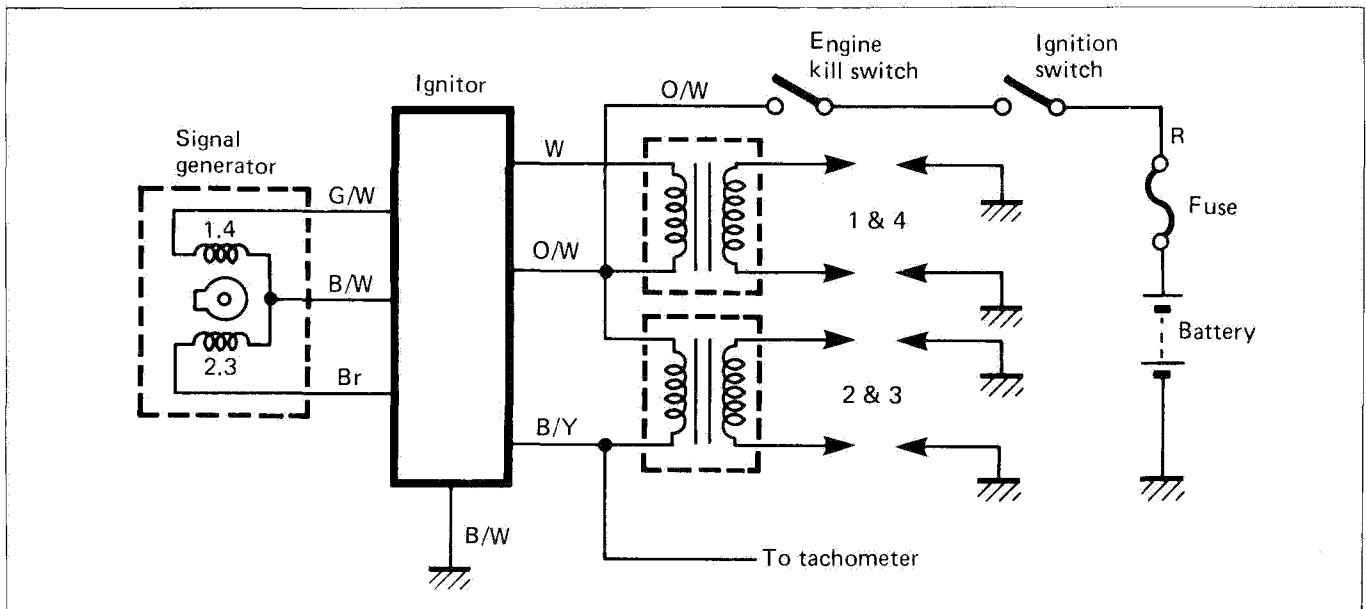

### INSPECTION

#### IGNITION COILS (Checking with Electro Tester)

Using the electro tester, test each ignition coil for sparking performance. The test connection is as indicated. Make sure that the three-needle sparking distance is at least 8 mm.

If no sparking or orange color sparking occurs with this much gap, then it is defective and must be replaced. Test for 5 minutes.

09900-28106	Electro tester
STD Spark performance	8 mm

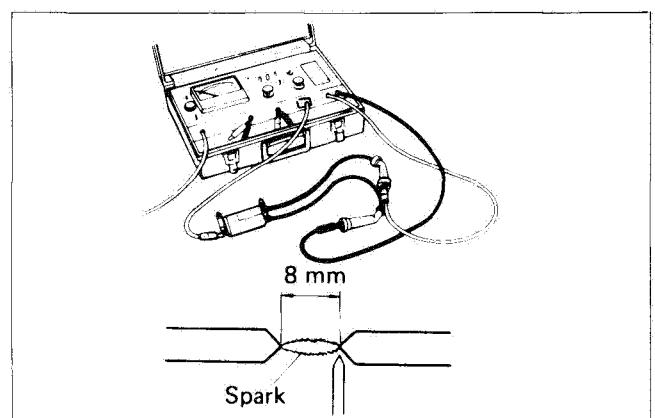

**IGNITION COILS (Checking with Pocket Tester)**

A SUZUKI pocket tester or an ohm meter may be used, instead of the electro tester. In either case, the ignition coil is to be checked for continuity in both primary and secondary windings. Exact ohmic readings are not necessary, but, if the windings are in sound condition, their continuity will be noted with these approximate ohmic values.

09900-25002	Pocket tester
-------------	---------------

Ignition coil resistance	
Primary	Approx. 3 – 7 $\Omega$
Secondary	Approx. 30 – 60 k $\Omega$

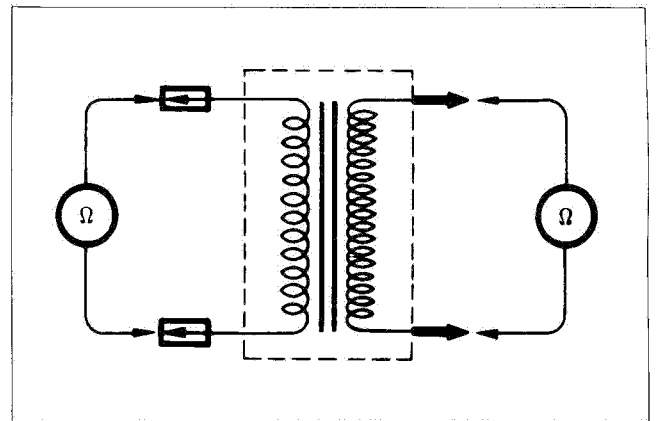
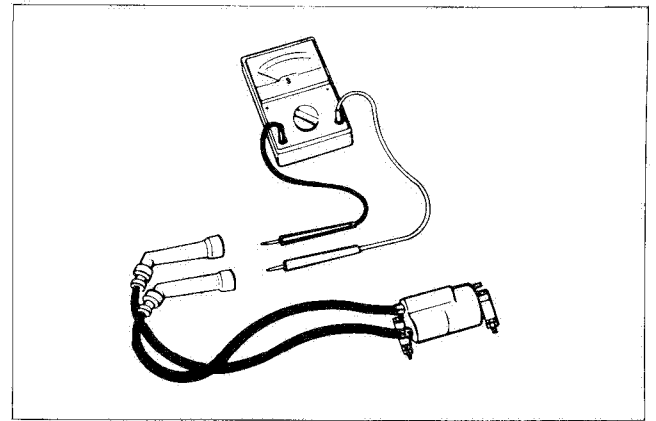
**SIGNAL GENERATOR**

Measure the resistance between lead wires.

If the resistance noted to show infinity or too low a resistance value, it must be replaced.

09900-25002	Pocket tester
-------------	---------------

STD resistance	
Br – B/W	250 – 500 $\Omega$
G/W – B/W	

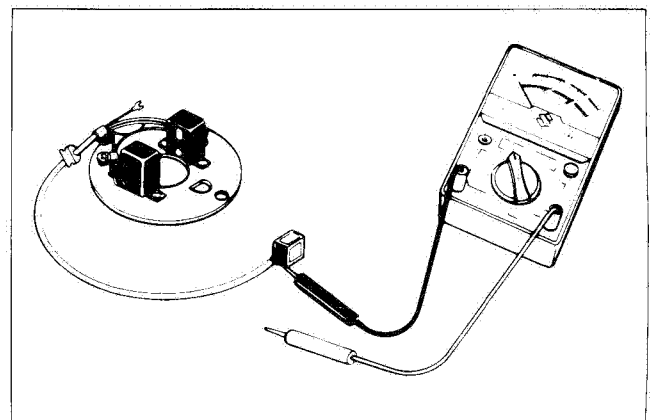
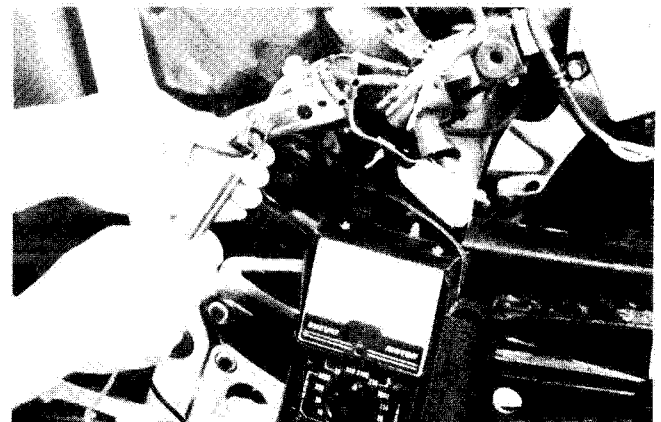

**IGNITOR UNIT**

- Remove both spark plugs (Nos. 1 and 2) from the cylinder head, and place both spark plugs on the cylinder head with the respective spark plug cap attached as shown in the fig.
- Remove the left frame cover.
- Disconnect the signal generator lead wire coupler from the ignitor. Turn the ignition switch to the ON position.
- Using the special tool (SUZUKI POCKET TESTER), check the ignitor unit. (Set the tester to RX1)
- Connect the  $\ominus$  pin of the pocket tester ( $\times 1\Omega$  range) to B/BI, and then connect the  $\oplus$  pin to Br and G/W alternately. If the No.2 plug sparks, with the  $\oplus$  pin connected to Br, and if the No.1 sparks, with the  $\oplus$  pin to G/W, the ignitor is good.

If there is no spark under the above conditions, replace the ignitor unit with a new one.

**NOTE:**

This check should be made after verifying that the ignition coil is good.

**CAUTION:**

Each test should be done within one minute.

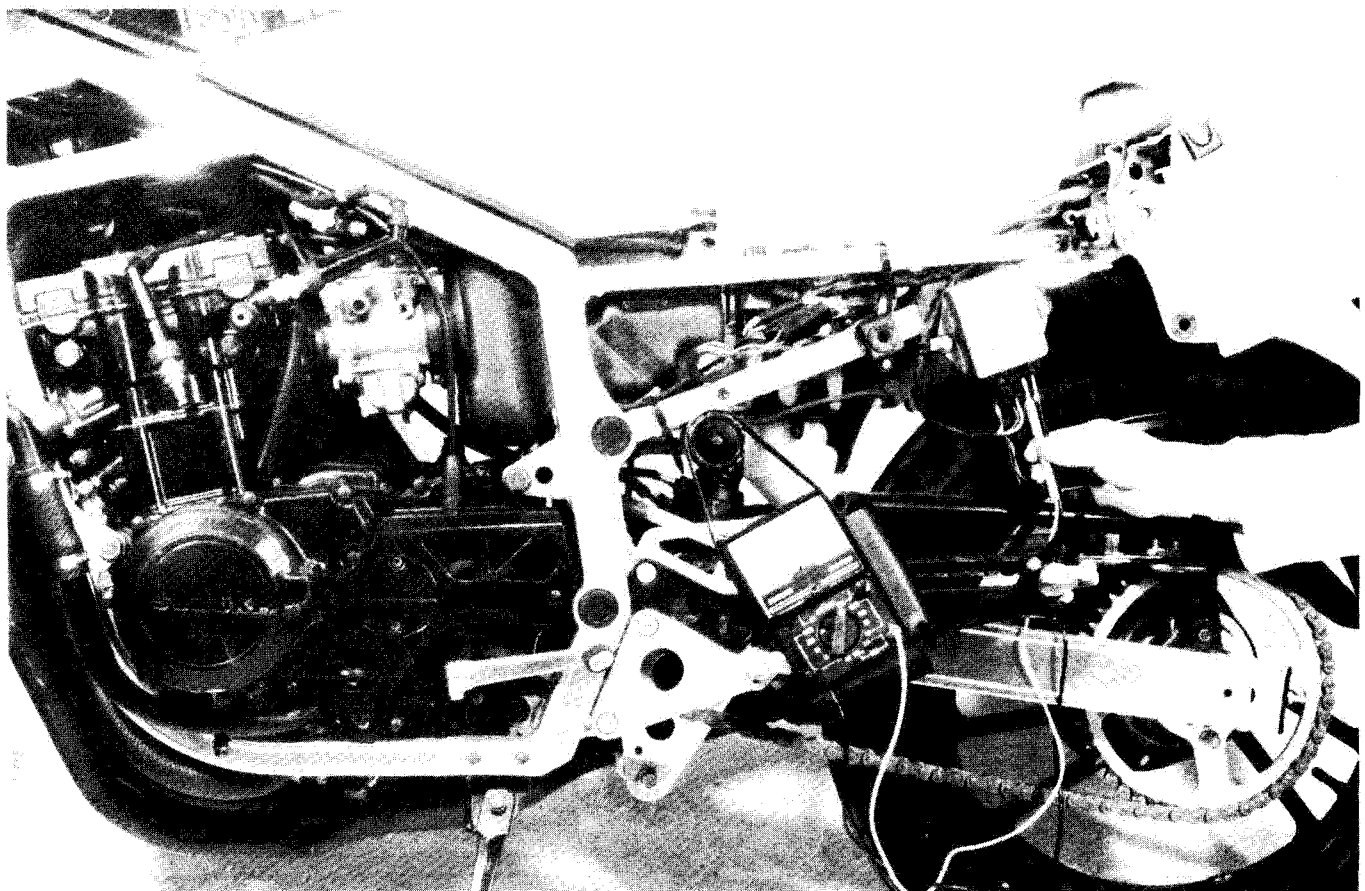





## STARTER MOTOR INSPECTION

### CARBON BRUSHES

When the brushes are worn, the motor will be unable to produce sufficient torque, and the engine will be difficult to turn over. To prevent this, periodically, inspect the length of the brushes, replacing them when they are too short or chipping.

Service Limit	9 mm
---------------	------

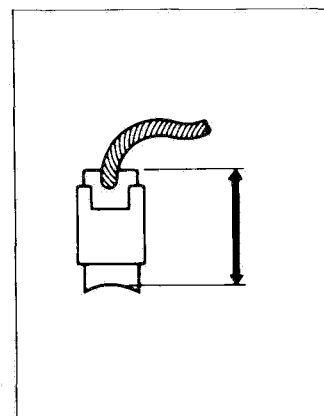
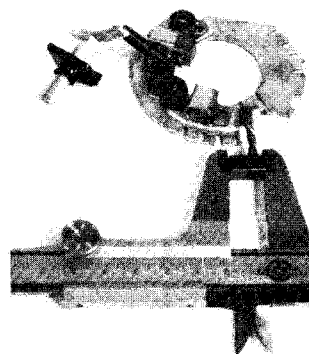

### COMMUTATOR

If the commutator surface is dirty, starting performance decrease. Polish the commutator with #400 or similar fine emery paper when it is dirty. After polishing wipe the commutator with a clean dry cloth.

Measure the commutator under-cut ①.

Service Limit	0.2 mm
---------------	--------

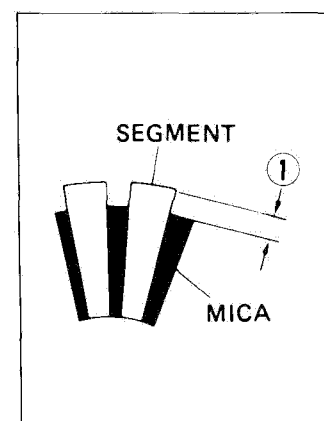
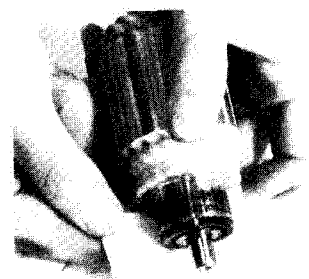

### ARMATURE COIL

Using a pocket tester, check the coil for open and ground by placing probe pins on each commutator segment and rotor core (to test for ground) and on any two segments at various places (to test for open), with the brushes lifted off the commutator surface.

If the coil is found to be open-circuited or grounded, replace the armature. Continuous use of a defective armature will cause the starter motor to suddenly fail.

09900-25002	Pocket tester
-------------	---------------

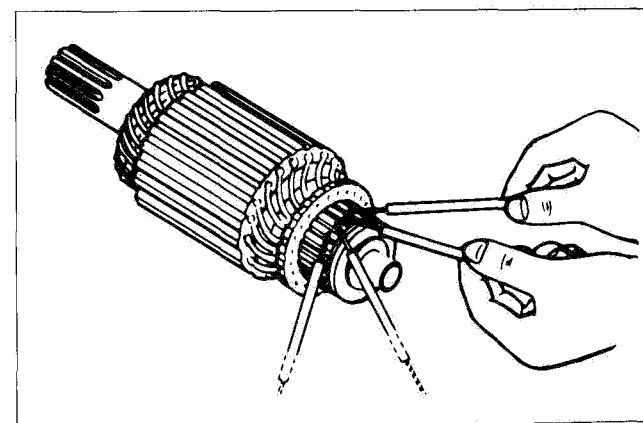
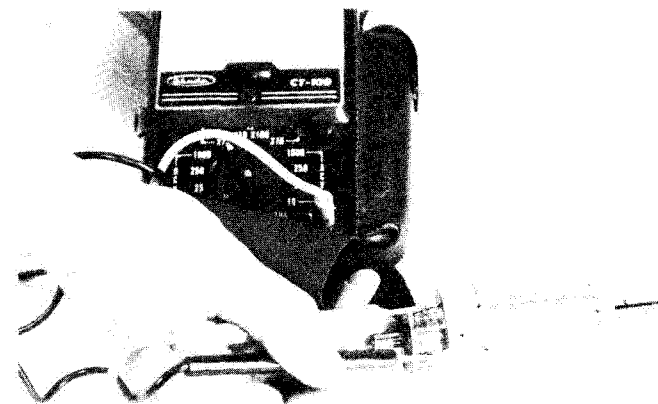

## STARTER MOTOR REASSEMBLY BRUSH HOLDER

When fixing brush holder to starter motor case, align the protrusion ① of the starter motor case with the notch ② of the brush holder.

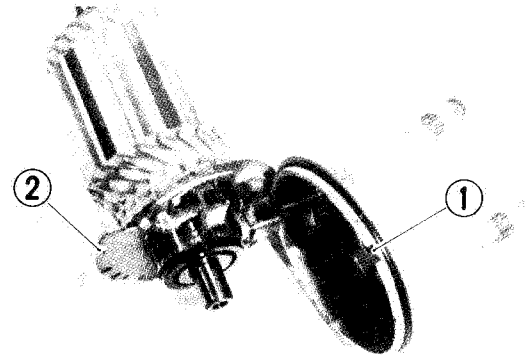

## HOUSING END

When installing housing end, fix the protrusion ③ of the starter motor case to the notch ④ on the housing end.

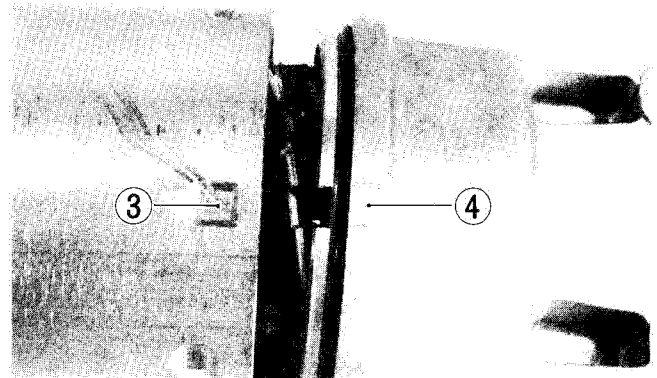

## SECURING SCREWS

Apply Thread Lock "1342" to starter motor securing screws.

99000-32050	Thread lock "1342"
-------------	--------------------

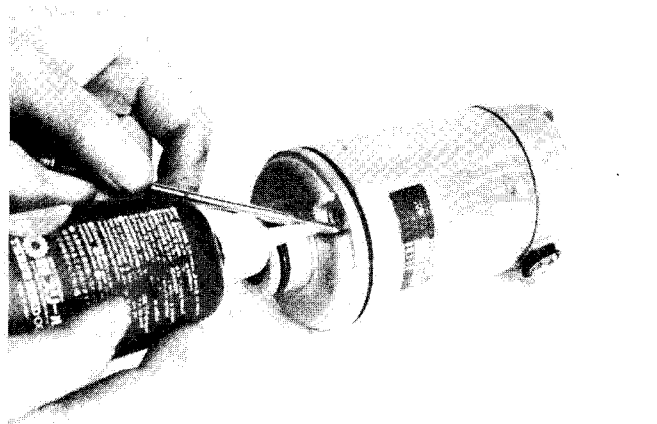

## STARTER RELAY INSPECTION

Disconnect lead wire of the starter motor at starter relay.

Turn on the ignition switch, inspect the continuity between the terminals, positive and negative, when pushing the starter button.

If the starter relay is in sound condition, continuity is found.

09900-25002	Pocket tester
-------------	---------------

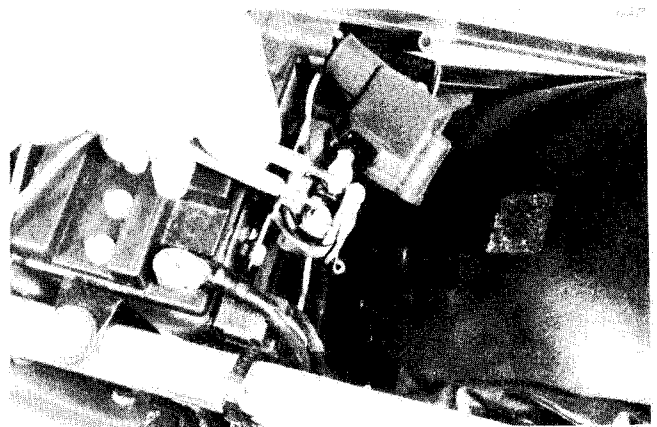

Check the coil for "open", "ground" and ohmic resistance. The coil is in good condition if the resistance is as follows.

09900-25002	Pocket tester
-------------	---------------

STD resistance	3 – 7Ω
----------------	--------

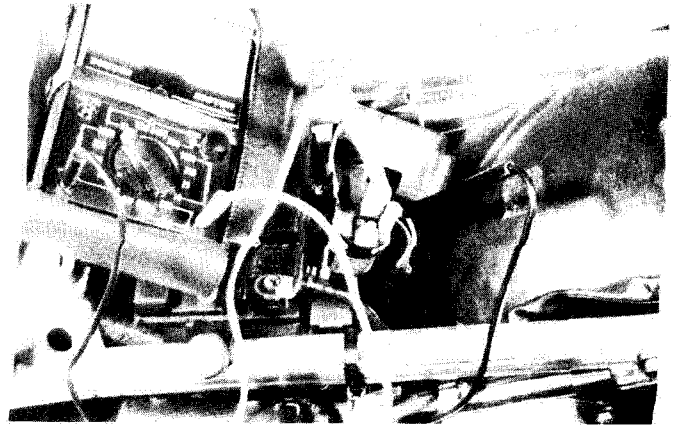

### COMBINATION METER

Remove the combination meter (See page 7-23).  
Disassemble the combination meter as follows.

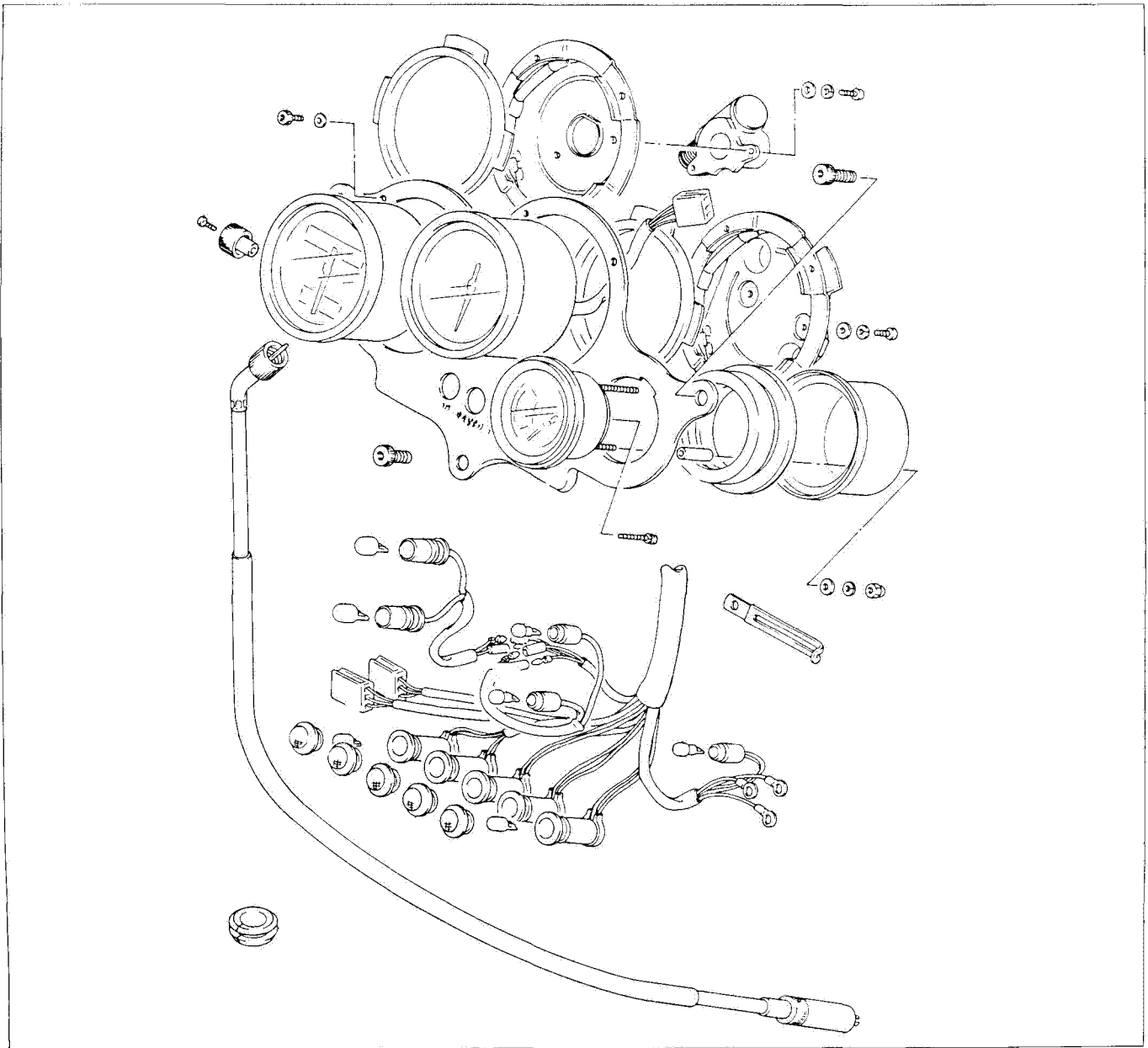

- Remove temperature meter cover.
- Remove speedometer gear box.

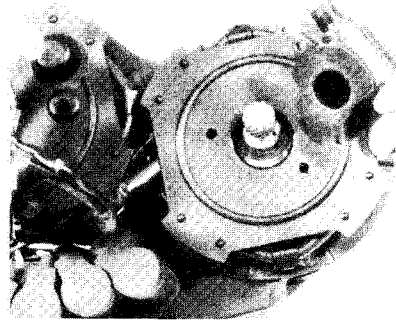

- Remove pilotlamp sockets.

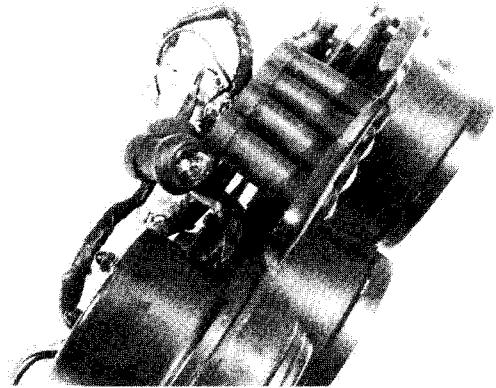

- Remove lamp lens.

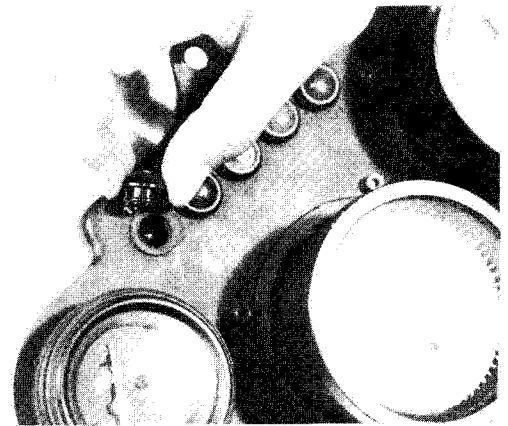

## WATER TEMPERATURE METER INSPECTION

As the coil spring is installed on the needle shaft of the water temperature meter, the needle is forcibly back to the original position when ignition switch is turned OFF.

To test the water temperature meter two different checks may be used. The first, and simplest test will tell if the meter is operating but will not indicate the meters accuracy throughout the range.

To perform this test, disconnect the B/G lead wire of the water temperature meter from the water temperature gauge. Connect a jumper wire between B/G wires coming from the main wiring harness and engine ground. With the ignition switch turned on, the water temperature meter should indicate "H".

The second test will check the accuracy of the meter in the "H" and "C" positions.

Connect a 130-ohm resistor between the B/G lead wire of the water temperature gauge and the ground lead wire. The water temperature gauge is normal if its pointer indicates the C position when the specified voltage is applied to the circuit and if its pointer indicates the H position when the resistor is changed to 17 ohms. If either one or both indications are abnormal, replace the water temperature meter with a new one.

## WATER TEMPERATURE METER

POSITION	RESISTANCE
①	130 $\Omega$
②	56 $\Omega$
③	17 $\Omega$

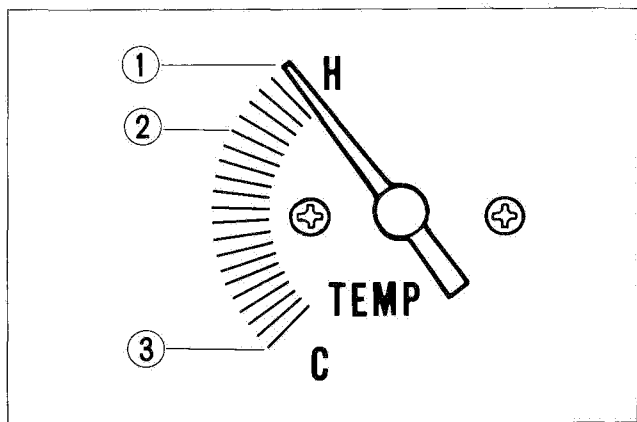
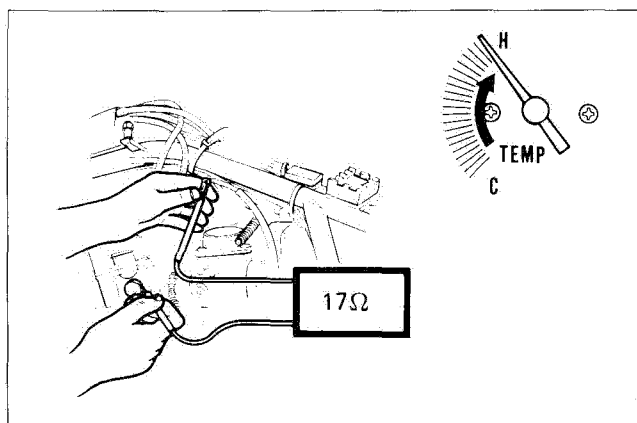
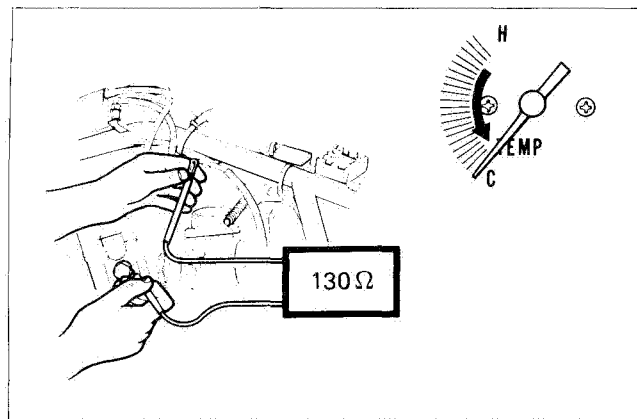

## LAMPS

### HEADLIGHT

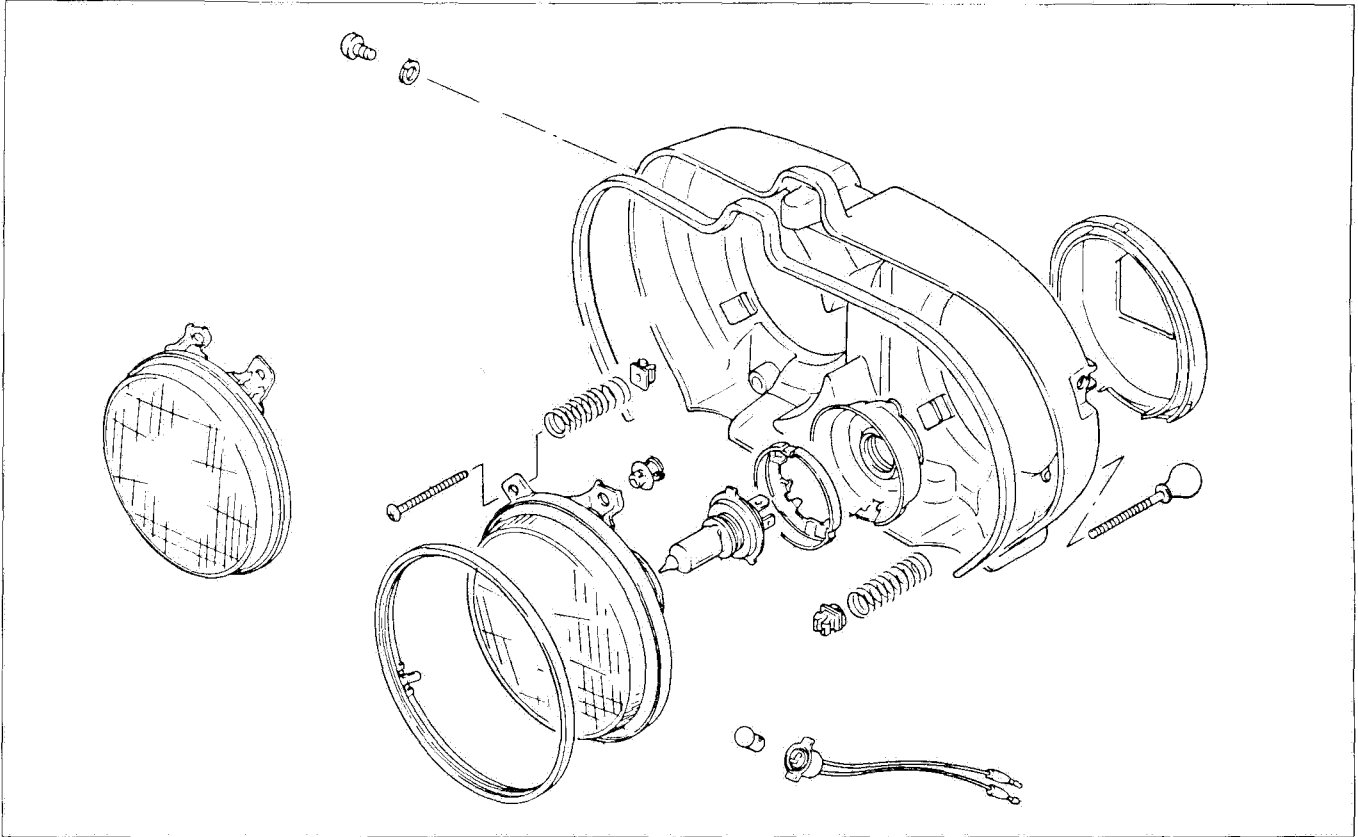

- Remove the headlight.
- Remove headlight cover and socket cover.
- Remove headlight by removing adjusting screw nut.

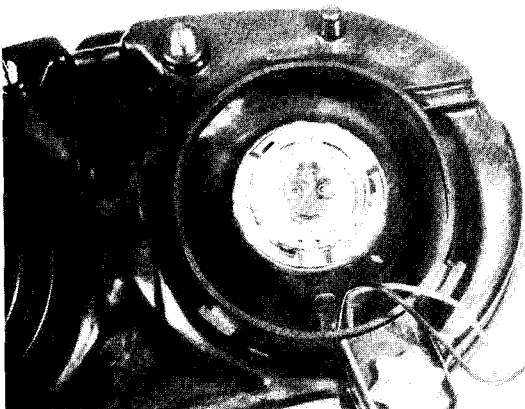
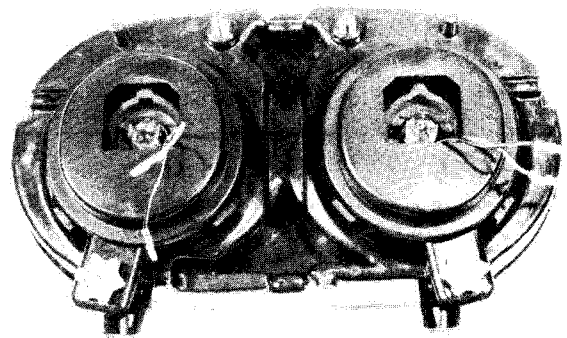

### TURN SIGNAL LIGHT AND TAIL/BRAKE LIGHT

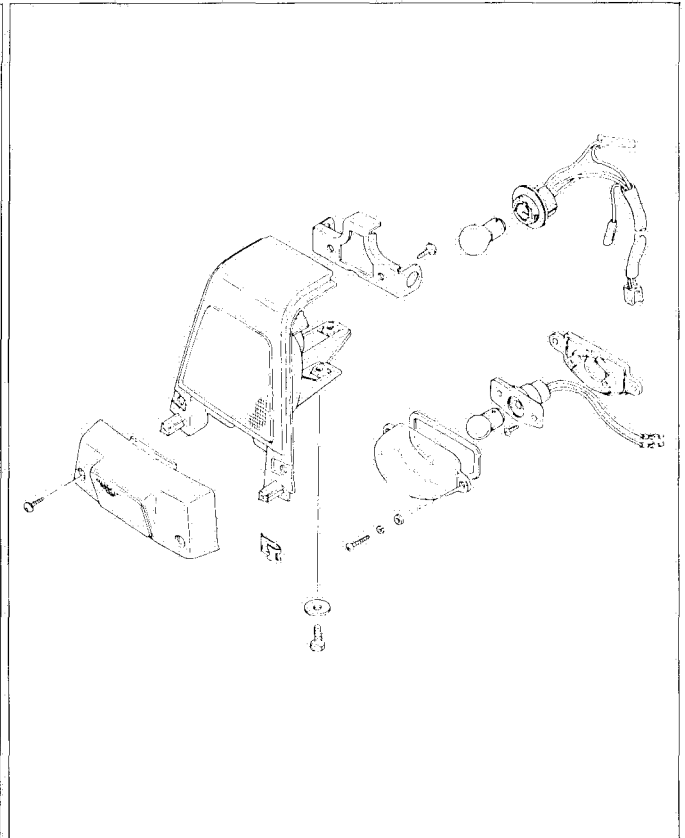
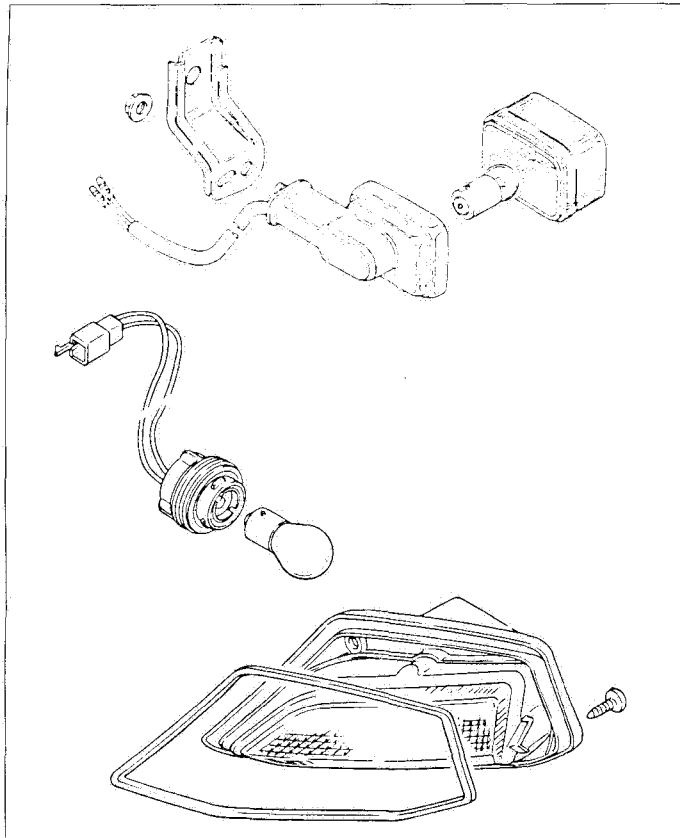

### SWITCHES

Inspect each switch for continuity with the pocket tester referring to the chart.

If it is found any abnormality, replace the respective switch assemblies with new ones.

09900-25002	Pocket tester
-------------	---------------

### IGNITION SWITCH

	B/W	Bl/W	R	O	Gr	Br	O/Bl
C	<input type="checkbox"/>	<input type="checkbox"/>	<input type="checkbox"/>	<input type="checkbox"/>			
ON				<input type="checkbox"/>	<input type="checkbox"/>	<input type="checkbox"/>	<input type="checkbox"/>
P			<input type="checkbox"/>			<input type="checkbox"/>	

### ENGINE STOP AND STARTER SWITCH

	O/Bl	O/W	Y/G
OFF			
RUN	<input type="checkbox"/>	<input type="checkbox"/>	
START		<input type="checkbox"/>	<input type="checkbox"/>

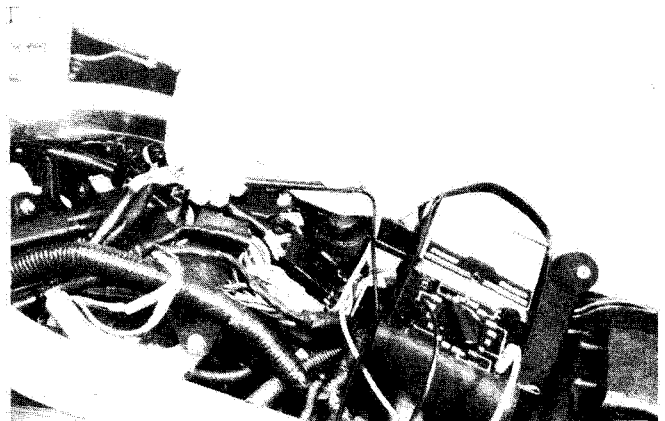



**LIGHTING SWITCH**

	O/R	Gr	Y/W	W/R	W/G
OFF					
ON	○	○	○	○	○

**FRONTBRAKE RIGHT SWITCH**

	O	W/B
OFF		
ON	○	○

**LIGHTING & PASSING SWITCH**

	W	Y	Y/W	O/R
HI		○	○	
LO	○		○	
PA	○	○	○	○

**TURN SIGNAL LIGHT SWITCH**

	B	Lbl	Lg
R		○	○
•			
L	○	○	

**HORN SWITCH**

	G	B/W
OFF		
HORN	○	○

**REAR BRAKE LIGHT SWITCH**

	W/B	O
OFF		
ON	○	○

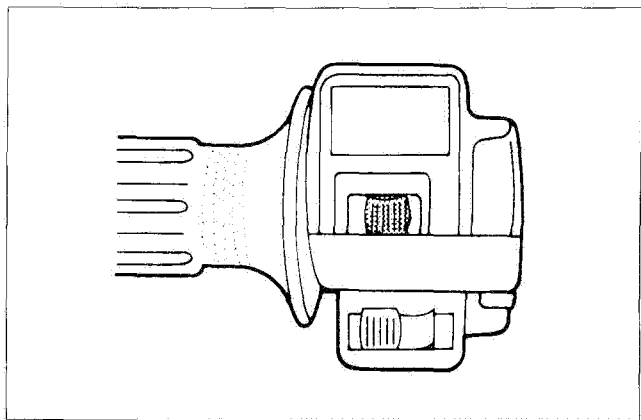
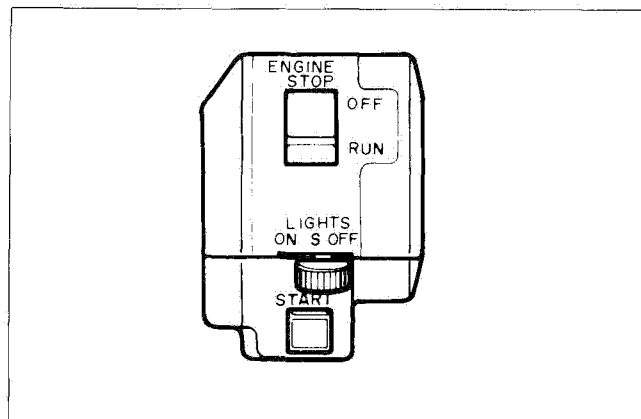
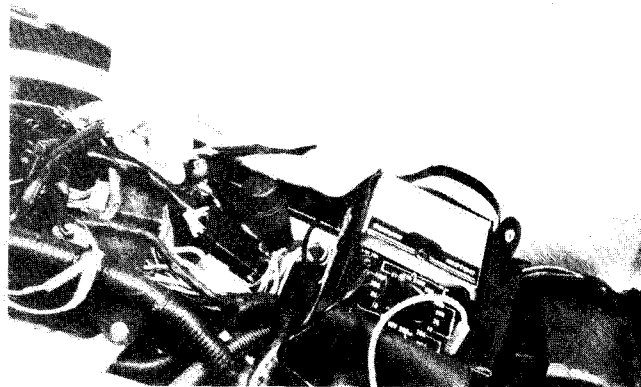

## BATTERY

### SPECIFICATIONS

Type designation	YB10L-B2
Capacity	12V, 39.6kC (11Ah)/10 HR
Standard electrolyte S.G.	1.28 at 20°C (68°F)

In fitting the battery to the motorcycle, connect the breather tube to the battery vent.

### INITIAL CHARGING

#### Filling electrolyte

Remove short sealed tube before filling electrolyte. Fill battery with electrolyte (dilute sulfuric acid solution with acid concentration of 35.0% by weight, having a specific gravity of 1.28 at 20°C (68°F)) up to indicated MAX. LEVEL. Filling electrolyte should be always cooled below 30°C (86°F) before filling into battery. Leave battery standing for half an hour after filling. Add additional electrolyte if necessary.

Charge battery with current as described in the table shown below.

Maximum charging current	1.2 A
--------------------------	-------

#### Charging time

The charging time for a new battery is determined by the number of months that have elapsed since the date of manufacture.

Date of manufacture is indicated by a three-part number, each indicating month, date and year.

Near the end of charging period, adjust the specific gravity of electrolyte to value specified. After charging, adjust the electrolyte level to the MAX. LEVEL with DISTILLED WATER.

### SERVICING

Visually inspect the surface of the battery container. If any signs of cracking or electrolyte leakage from the sides of the battery have occurred, replace the battery with a new one.

If the battery terminals are found to be coated with rust or an acidic white powder substance, then this can be cleaned away with emery paper.

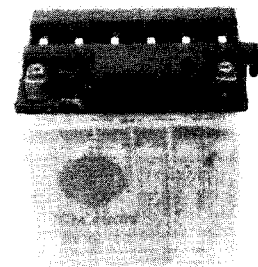
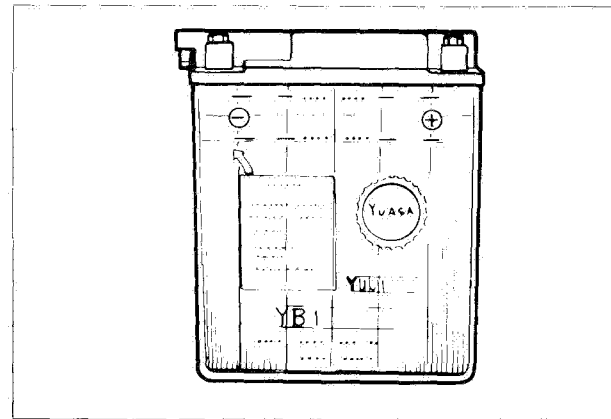

Months-after manufacturing	Within 6	Within 9	Within 12	Over 12
Necessary charging hours	20	30	40	60

Check the electrolyte level and add distilled water, as necessary, to raise the electrolyte to each cell's MAX. level.

Check the battery for proper charge by taking an electrolyte S.G. reading. If the reading is 1.22 or less, as corrected to 20°C (68°F), it means that the battery is still in a discharged condition and needs recharging.

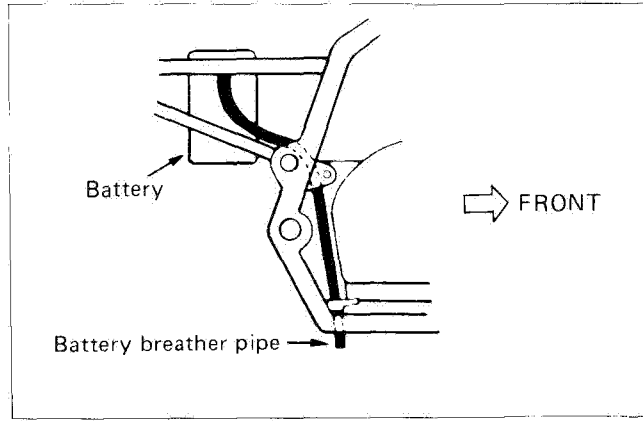

**BASED ON S.G. READING RECHARGING OPERATION**

To correct an S.G. reading 20°C (68°F), use the table at the right.

To read the S.G. on the hydrometer, bring the electrolyte in the hydrometer ① to eye level and read the graduations on the float scale bordering on the meniscus (curved-up portion of electrolyte surface), as shown in figure.

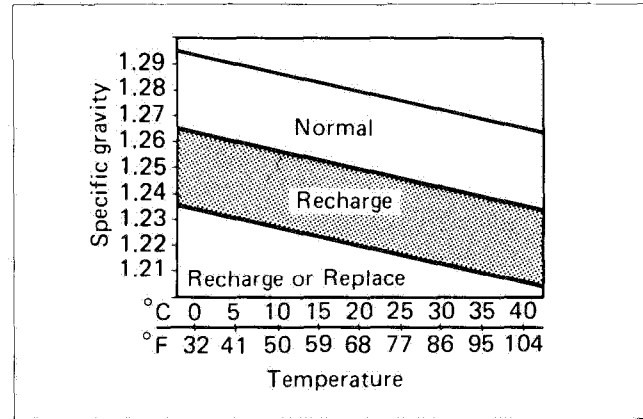

Check the reading (as corrected to 20°C) with chart to determine the recharging time in hours by constant-current charging at a charging rate of 1.2 amperes (which is a tenth of the capacity of the present battery).

Be careful not to permit the electrolyte temperature to exceed 45°C (113°F), at any time, during the recharging operation. Interrupt the operation, as necessary, to let the electrolyte cool down. Recharge the battery to the specification.

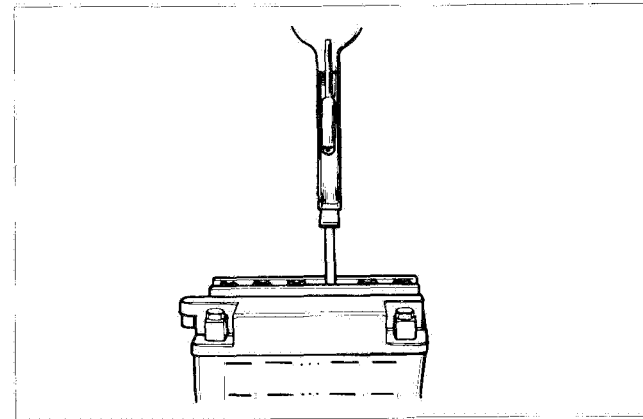

Electrolyte specific gravity	1.28 at 20°C (68°F)
------------------------------	---------------------

**CAUTION:**  
Constant-voltage charging, otherwise called "quick" charging, is not recommended as it could shorten the life of the battery.

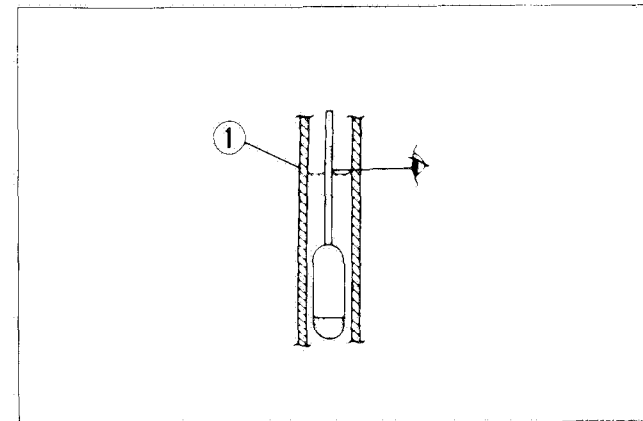

09900-28403	Hydrometer
-------------	------------

**WARNING:**

- \* Before charging a battery, remove the seal cap from each cell.
- \* Keep fire and sparks away from a battery being charged.
- \* When removing a battery from the motorcycle, be sure to remove the  $\ominus$  terminal first.

**SERVICE LIFE**

Lead oxide is applied to the pole plates of the battery which will come off gradually during the service life. When the bottom of the battery case becomes full of sediment, the battery cannot be used any more. If the battery is not charged for a long time, lead sulfate is generated on the surface of the pole plates and will deteriorate the performance (sulfation). Replace the battery with a new one in such a case.

When a battery is left for a long term without use, it is subject to sulfation. When the motorcycle is not used for more than 1 month (especially during the winter season), recharge the battery at least once a month.

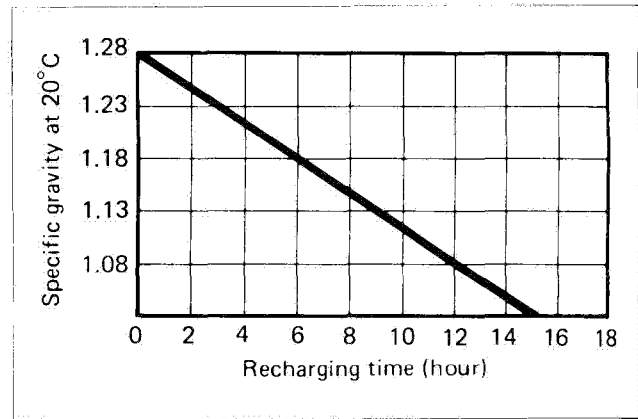

# CHASSIS

## CONTENTS

<i>FAIRING</i> .....	7- 1
<i>FRONT WHEEL</i> .....	7- 3
<i>FRONT BRAKE</i> .....	7- 8
<i>FRONT FORK</i> .....	7-16
<i>STEERING STEM</i> .....	7-22
<i>REAR BRAKE</i> .....	7-27
<i>REAR WHEEL</i> .....	7-34
<i>TIRE AND WHEEL</i> .....	7-41
<i>REAR SWINGARM AND SUSPENSION</i> .....	7-47

## FAIRING

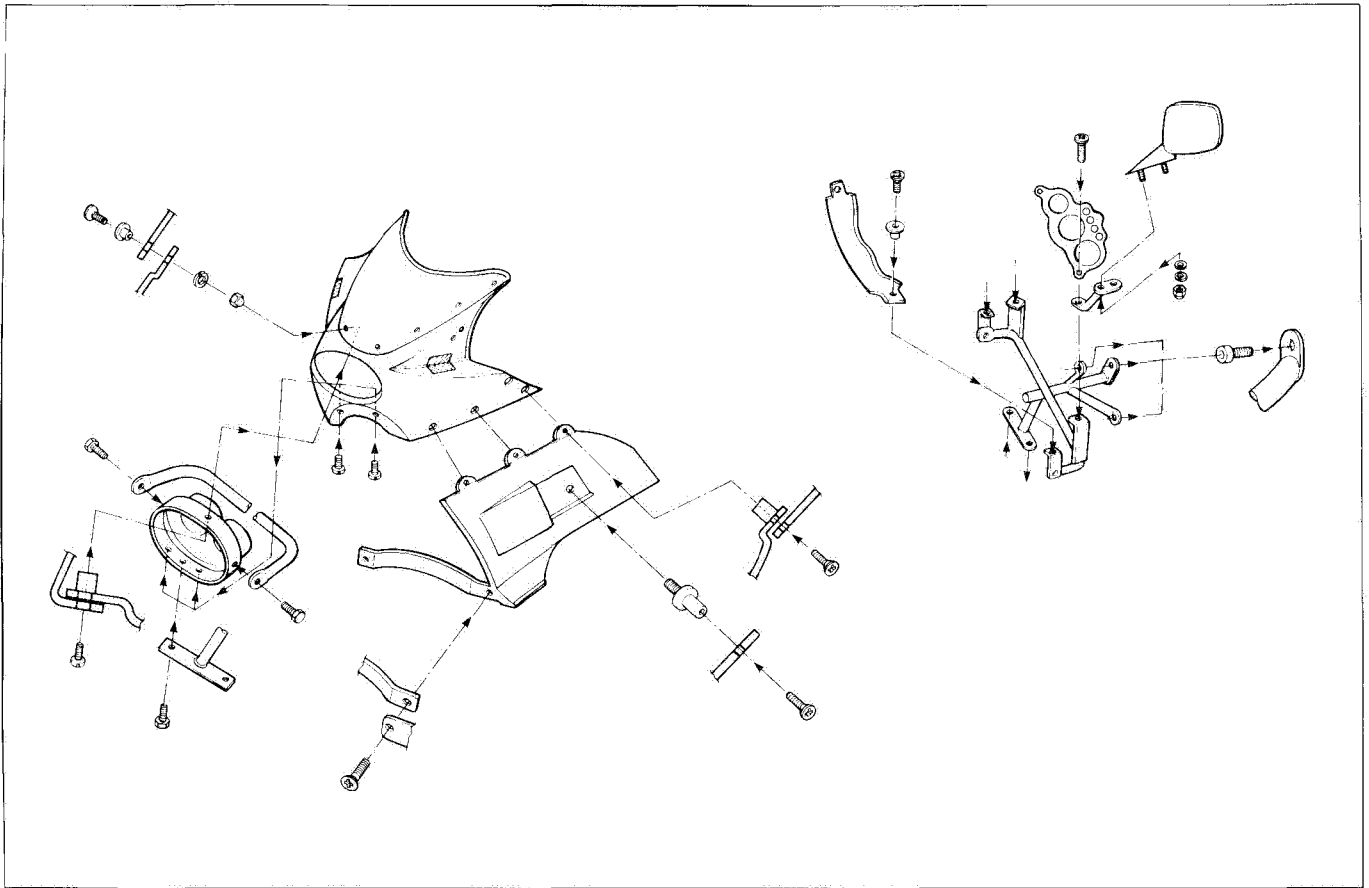

### REMOVAL

- Remove the right and left rear view mirror mounting nuts and disconnect turn signal lead wires.

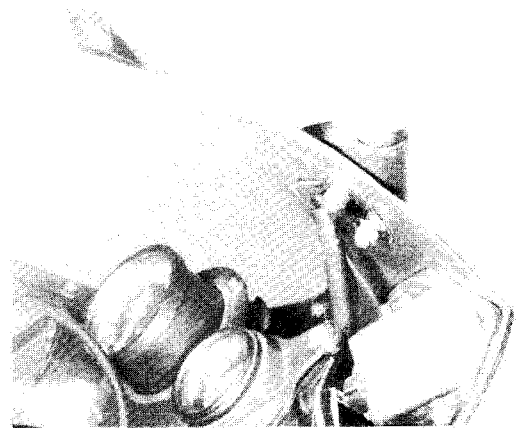

- Remove the two screws.

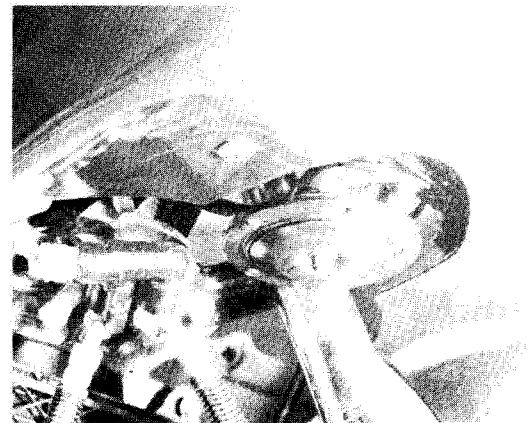

- Remove the screws.

09900-00401	L-type hexagon wrench set
-------------	---------------------------

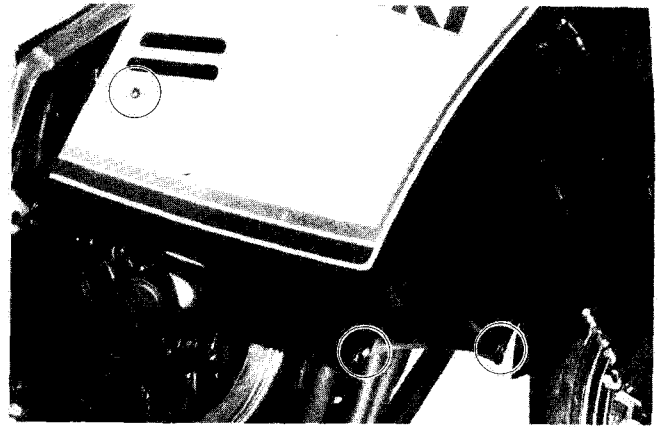

- Remove the three screws and take off the fairing.

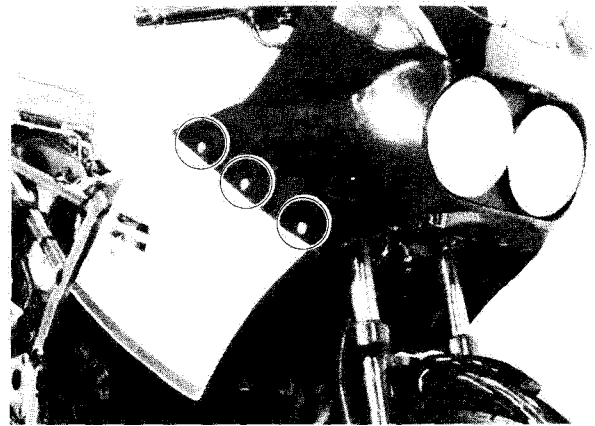

# FRONT WHEEL

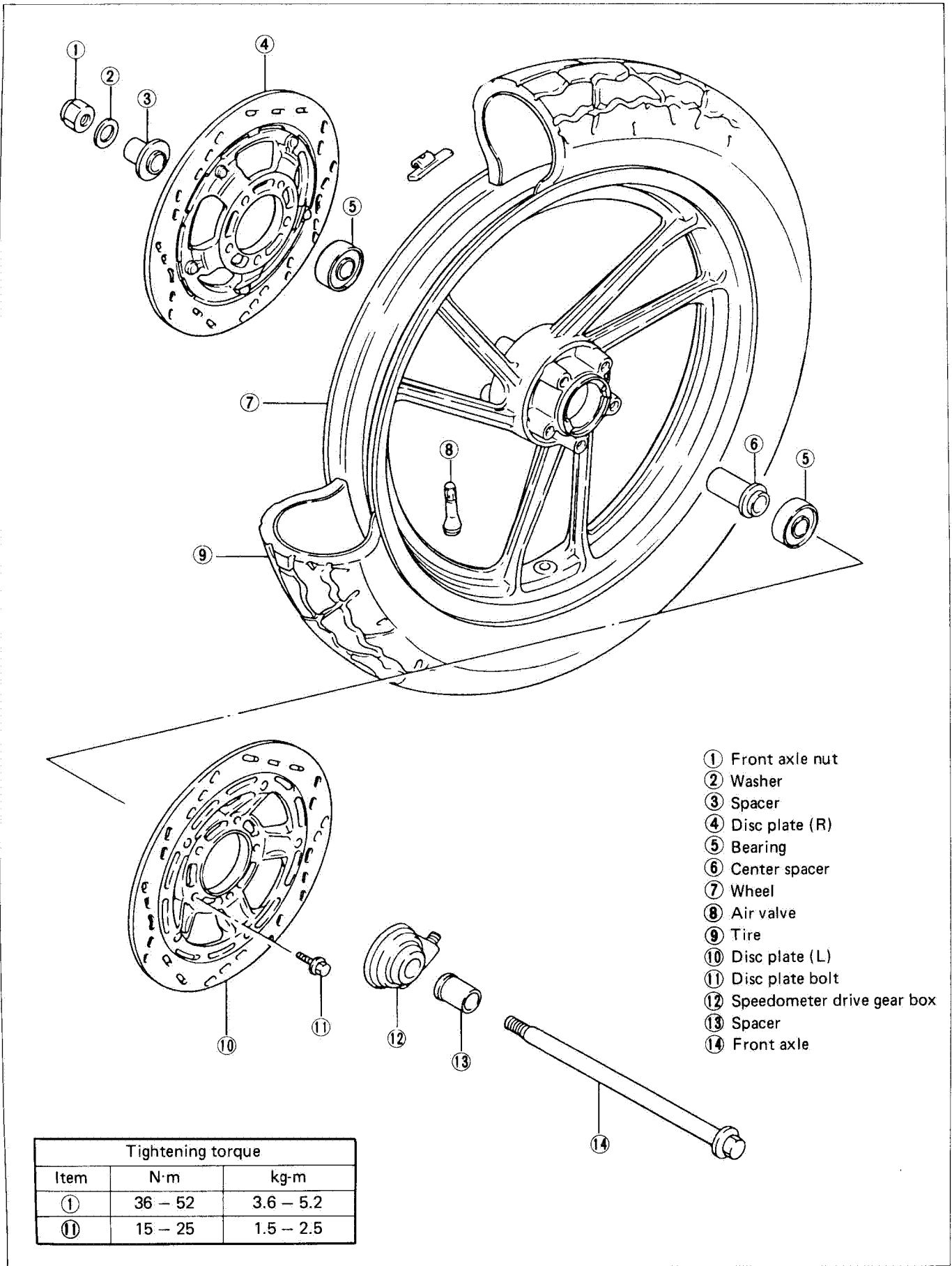

- ① Front axle nut
- ② Washer
- ③ Spacer
- ④ Disc plate (R)
- ⑤ Bearing
- ⑥ Center spacer
- ⑦ Wheel
- ⑧ Air valve
- ⑨ Tire
- ⑩ Disc plate (L)
- ⑪ Disc plate bolt
- ⑫ Speedometer drive gear box
- ⑬ Spacer
- ⑭ Front axle

Tightening torque		
Item	N·m	kg-m
①	36 - 52	3.6 - 5.2
⑪	15 - 25	1.5 - 2.5



## REMOVAL AND DISASSEMBLY

- Support the machine by jack with wooden block.
- Remove the axle nut and axle pinch bolt.
- Disconnect the speedometer cable.

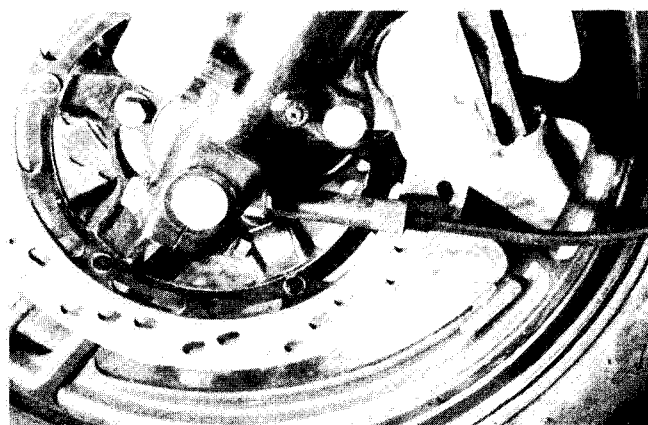

- Remove the caliper mounting bolts and dismount the both calipers.

### NOTE:

Do not operate the brake lever while dismounting the calipers.

- Draw out the axle shaft and take off front wheel.

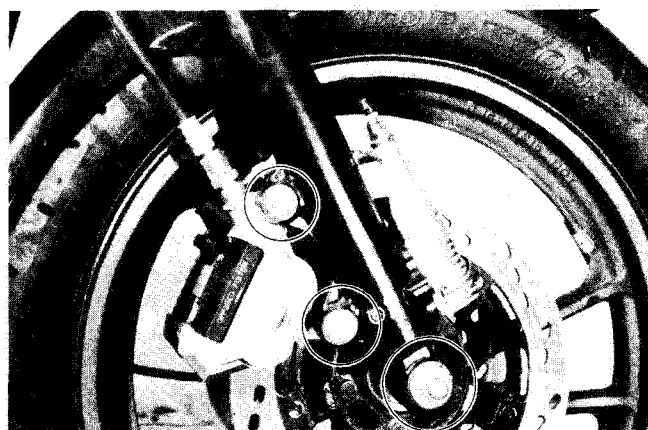

- Remove the securing bolts and separate the right and left discs from the wheel.

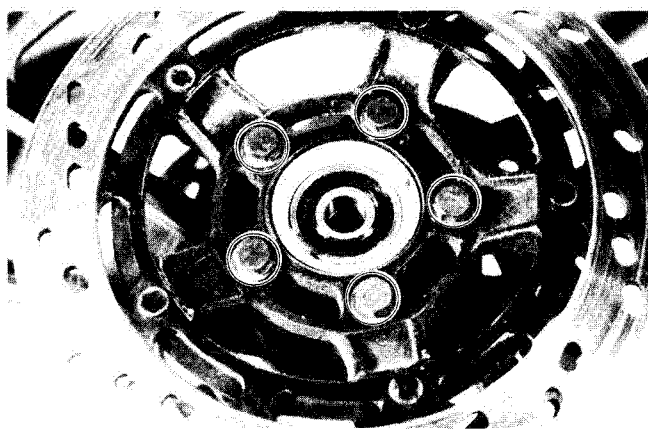

Drive out the right and left wheel bearings by using the special tool in the following procedures.

- Insert the adaptor into the wheel bearing.

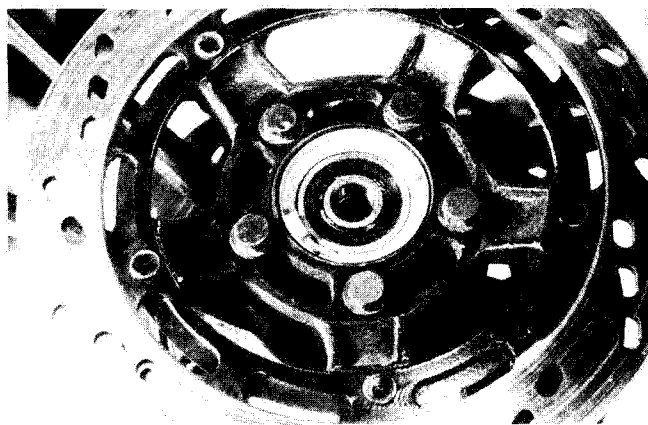

- After inserting the wedge bar from the opposite side, lock the wedge bar in the slit of the adapter.
- Drive out the wheel bearing by knocking the wedge bar.

**CAUTION:**

The removed bearing should be replaced.

09941-50110

Bearing remover

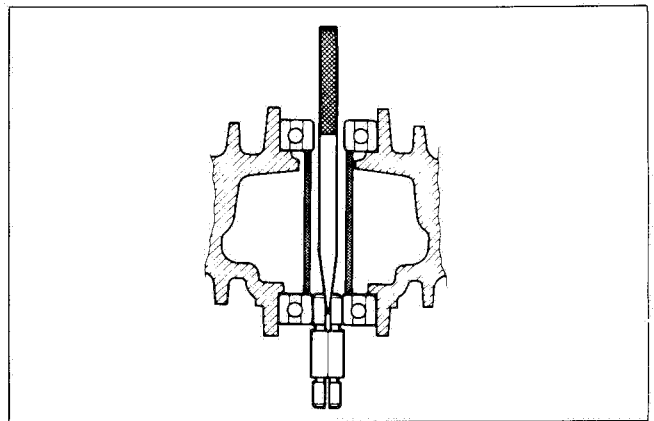
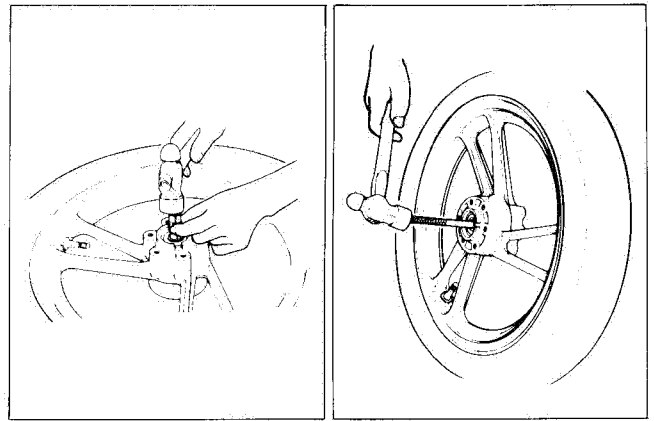

## INSPECTION

### WHEEL BEARINGS

Inspect the play of wheel bearing inner race by hand while it is in the wheel. Rotate the inner race by hand to inspect whether abnormal noise or smooth rotation. Replace the bearing if there is anything unusual.

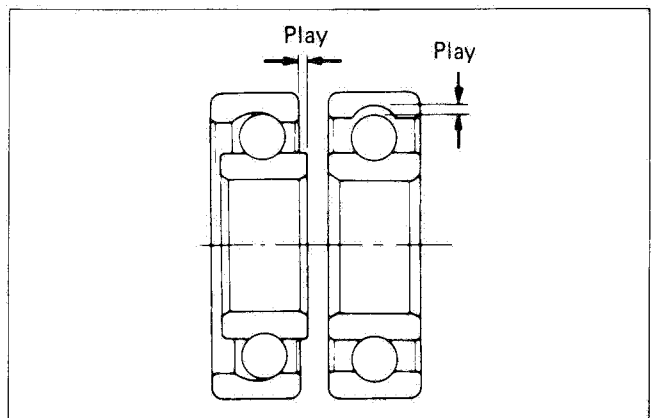

## AXLE SHAFT

Using a dial gauge, check the axle shaft for runout and replace it if the runout exceeds the limit.

09900-20606

Dial gauge (1/100)

09900-20701

Magnetic stand

Service Limit

0.25 mm

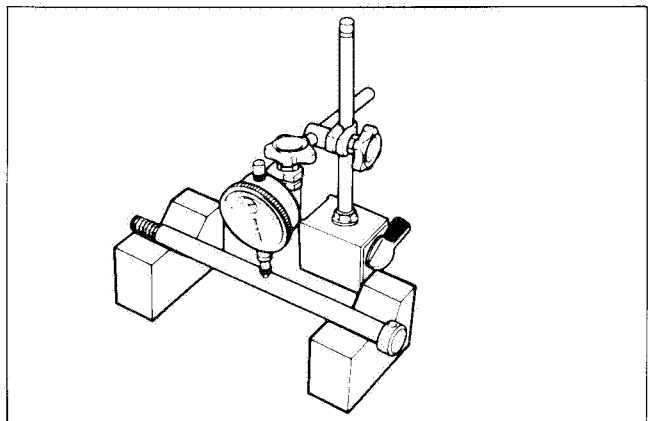

## WHEEL AND WHEEL RIM

Make sure that the wheel runout checked as shown does not exceed the service limit. An excessive runout is usually due to worn or loose wheel bearings and can be reduced by replacing the bearings. If bearing replacement fails to reduce the runout, replace the wheel.

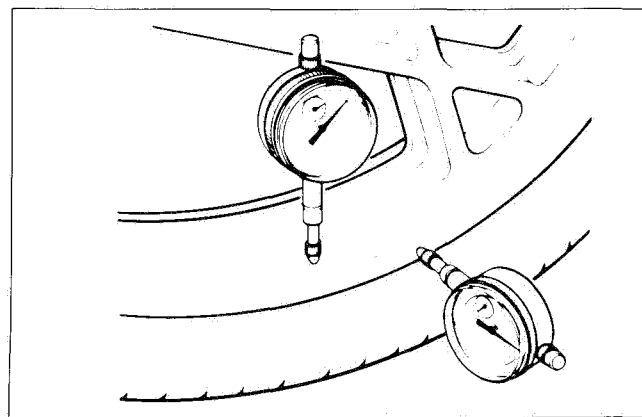

Service Limit (Axial and Radial)	2.0 mm
-------------------------------------	--------

## REASSEMBLY

Reassemble and remount the front wheel in the reverse order of disassembly and removal, and also carry out the following steps:

### WHEEL BEARING

Apply grease to the bearing before installing the bearings.

99000-25010	SUZUKI Super grease "A"
-------------	-------------------------



Install the wheel bearings as follows by using the special tool.

### CAUTION:

First install the wheel bearing for left side.

09924-84510	Bearing installer set
-------------	-----------------------

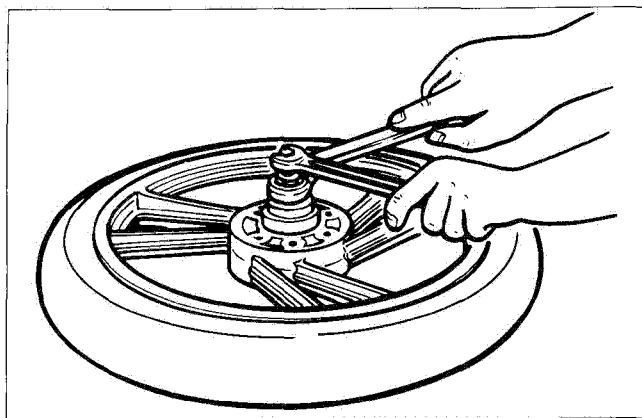

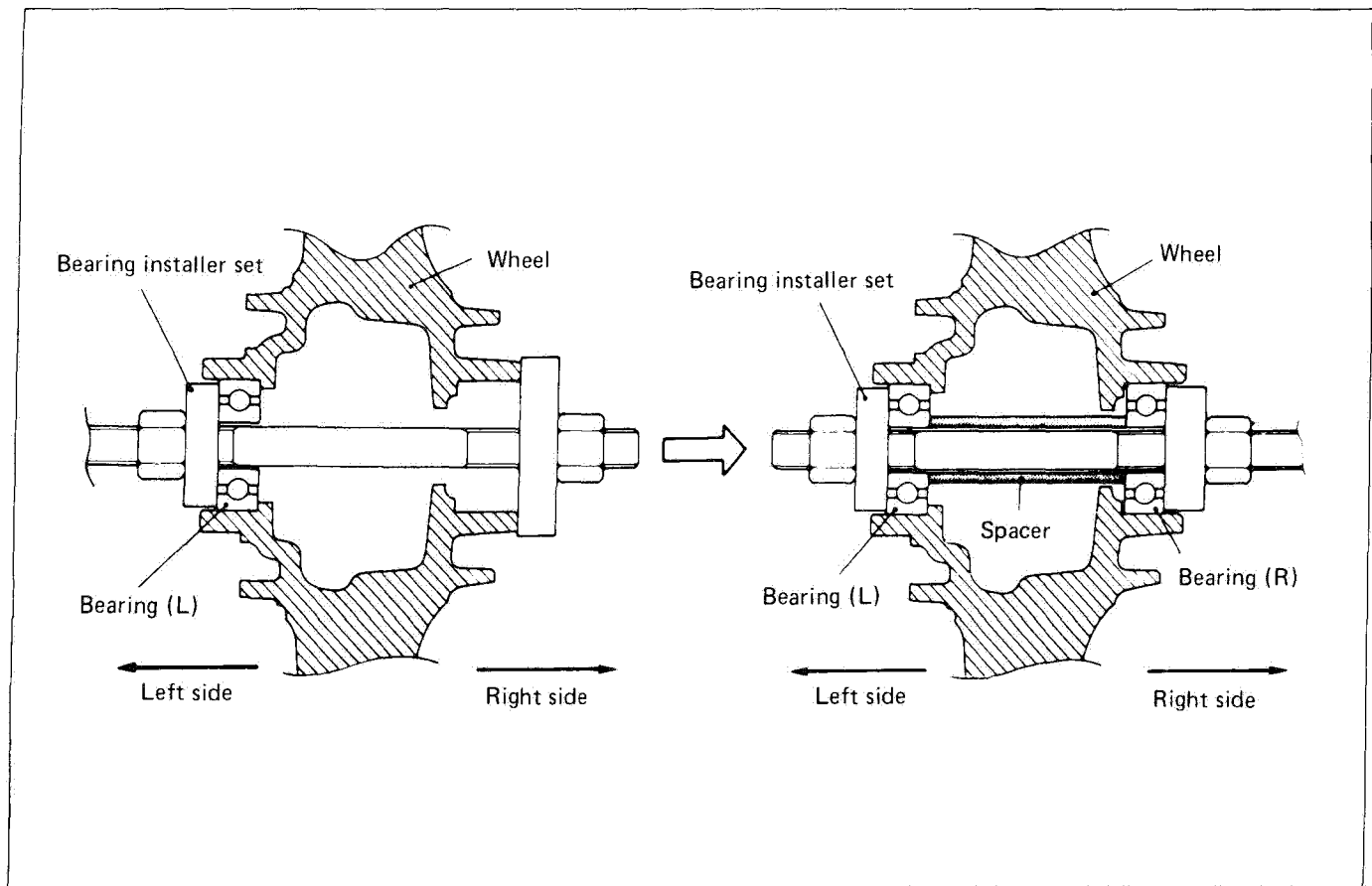

Make sure that the brake disc is clean and free of any greasy matter. Apply Thread Lock "1360" to the bolt and tighten them to the specified torque.

99000-32130	Thread Lock "1360"
-------------	--------------------

Tightening torque	15 – 25 N·m (1.5 – 2.5 kg·m)
-------------------	---------------------------------

Before installing the speedometer gearbox, grease it and align the two drive pawls ① to the two recesses ② of the wheel hub and attach the speedometer gearbox to the wheel hub.

When tightening the front axle, check to be sure that the speedometer gearbox is in the position so that the speedometer cable does not bend sharply.

#### TIGHTENING TORQUE

ITEM	N·m	kg·m
Axle nut	36 – 52	3.6 – 5.2
Axle holder nut	15 – 25	1.5 – 2.5

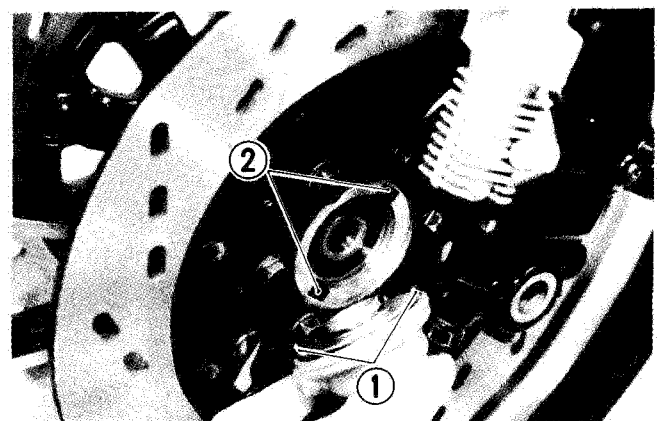
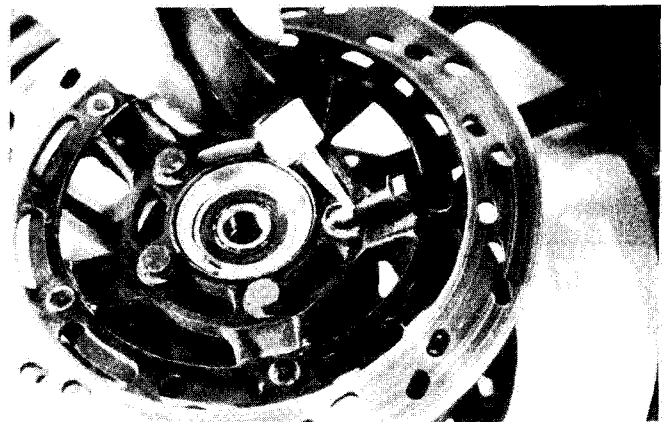

**FRONT WHEEL ASSEMBLY**

Remount the front wheel assembly as shown in the illustration.

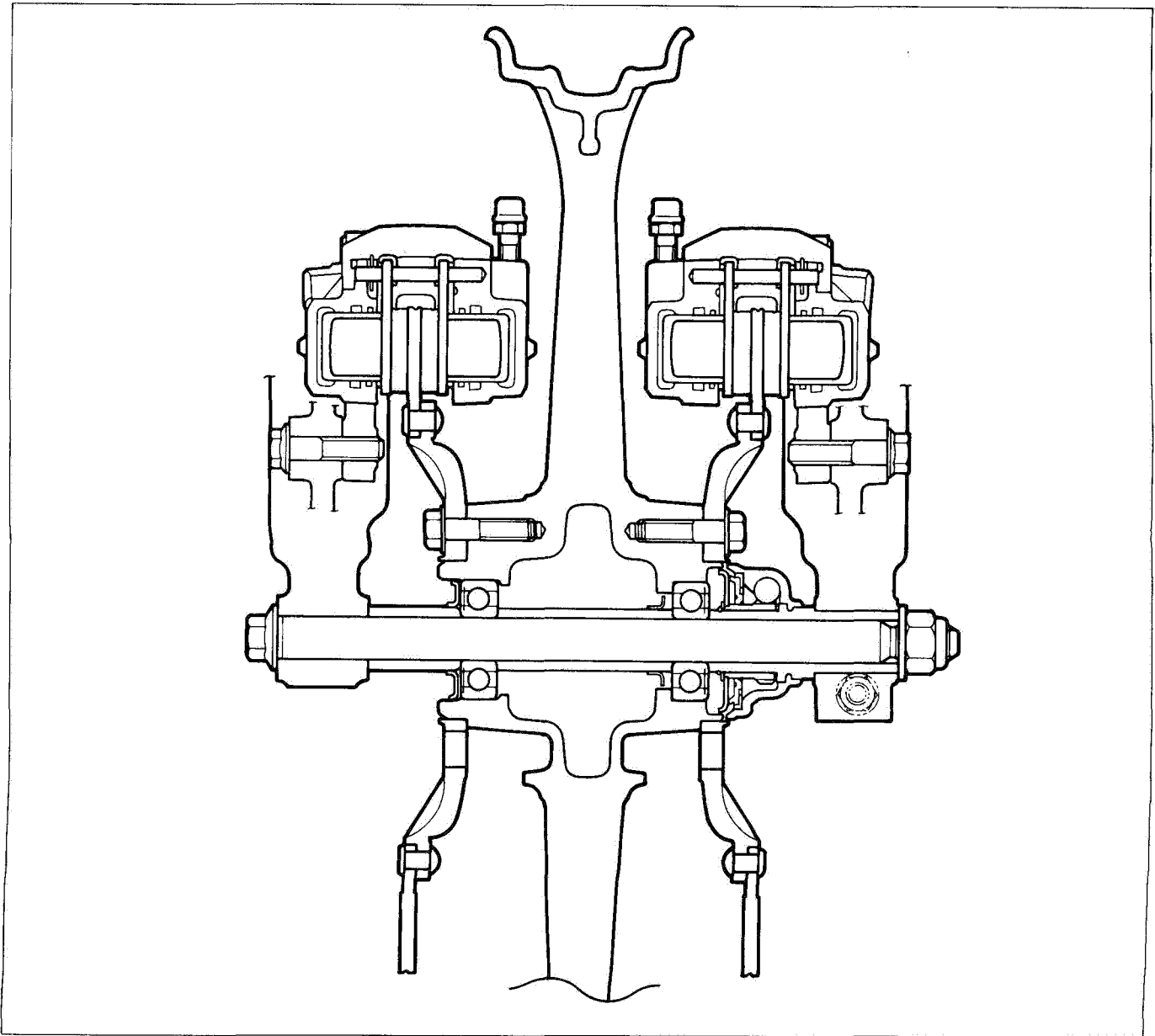
**NOTE:**

Push the pistons all the way into the caliper and remount the calipers.

Caliper mounting bolt tightening torque	15 – 25 N·m (1.5 – 2.5 kg-m)
---	---------------------------------

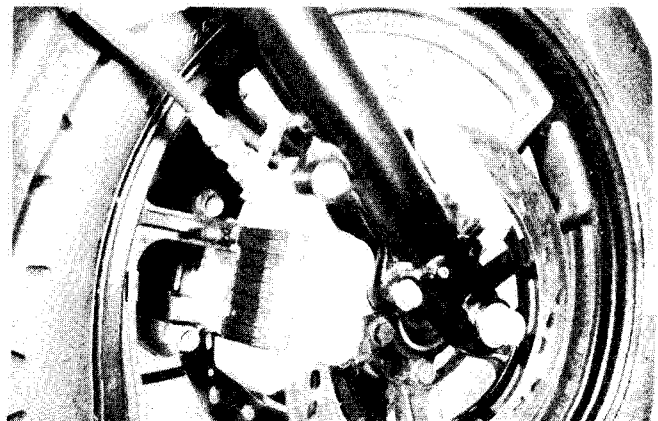

# FRONT BRAKE

## CONSTRUCTION (MASTER CYLINDER AND CALIPER)

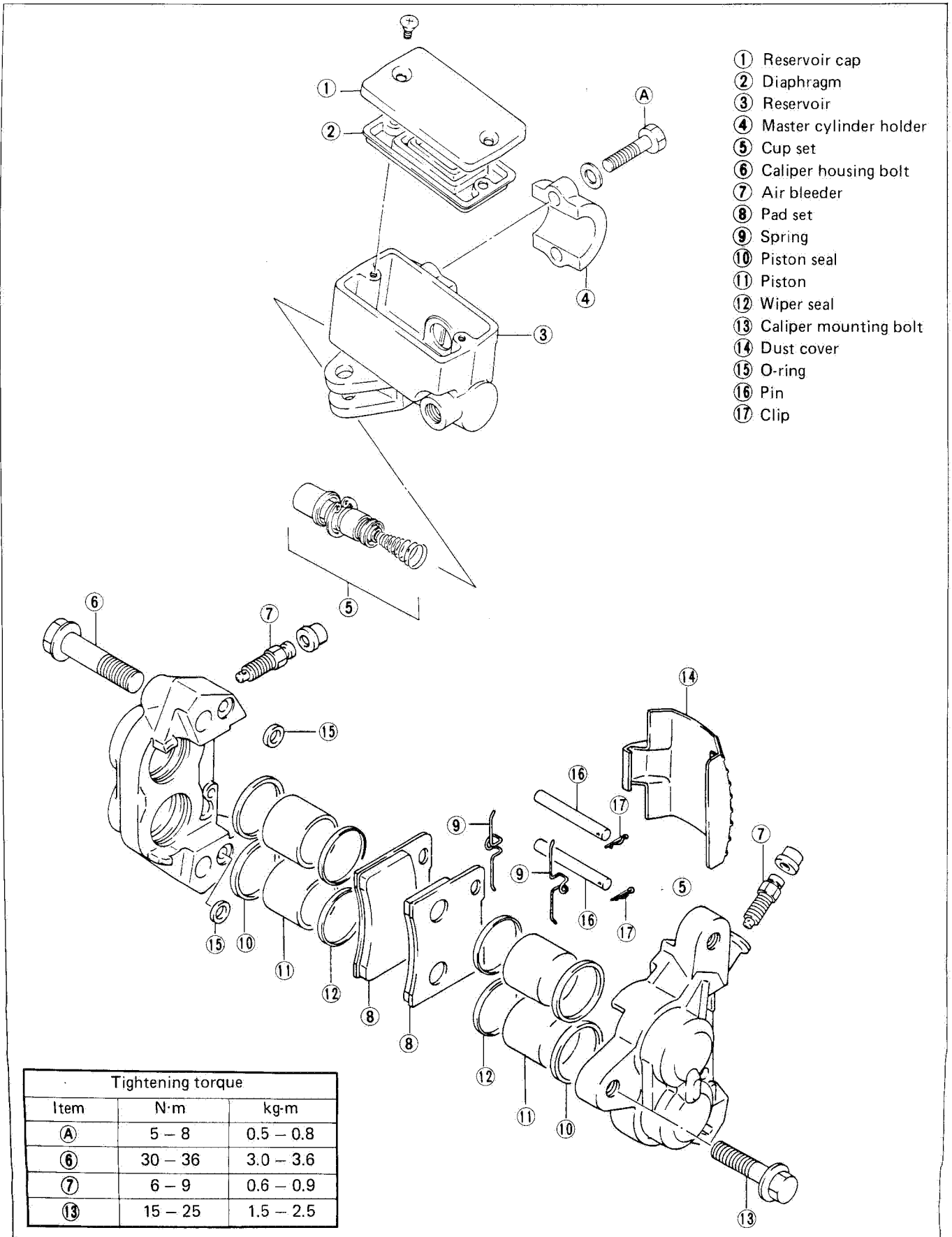

## CALIPER REMOVAL AND DISASSEMBLY

- Loosen the nut ② while holding the lock nut ①.
- Disconnect brake hose and catch the brake fluid in a suitable receptacle.
- Remove the union bolt ③ and disconnect the anti-dive hose from the caliper.

### CAUTION:

Never re-use the brake fluid left over from the last servicing and stored for long periods.

### WARNING:

Brake fluid, if it leaks, will interfere with safe running and discolor painted surfaces. Check the brake hose and hose joint for cracks and oil leakage before riding.

- Remove the dust cover ④.
- Remove the clips ⑤ and spring ⑥, and draw out the pins ⑦.
- Take off the pads.

- Remove the caliper housing bolts and separate the caliper halves.

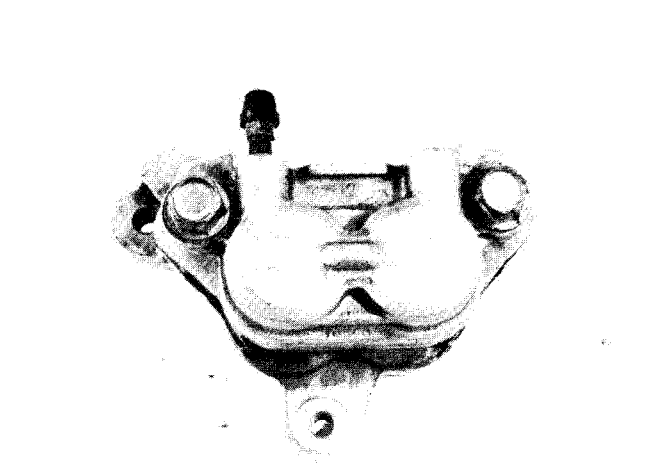
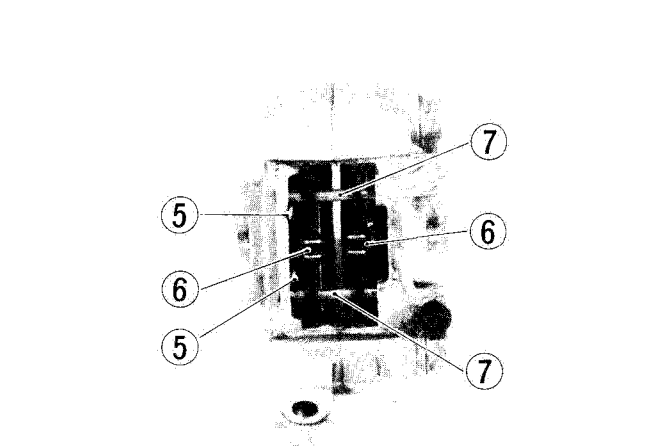
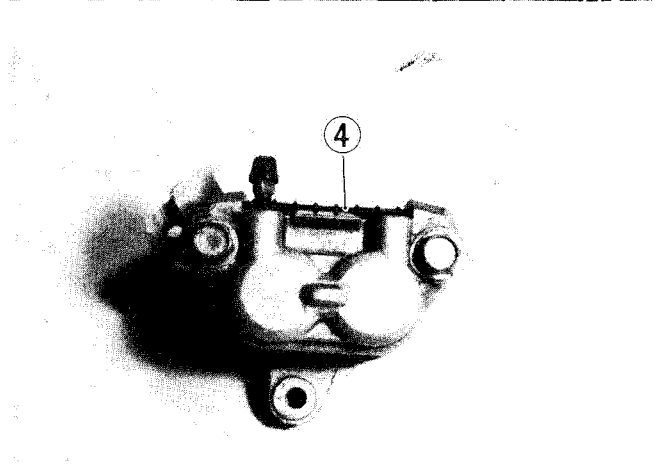
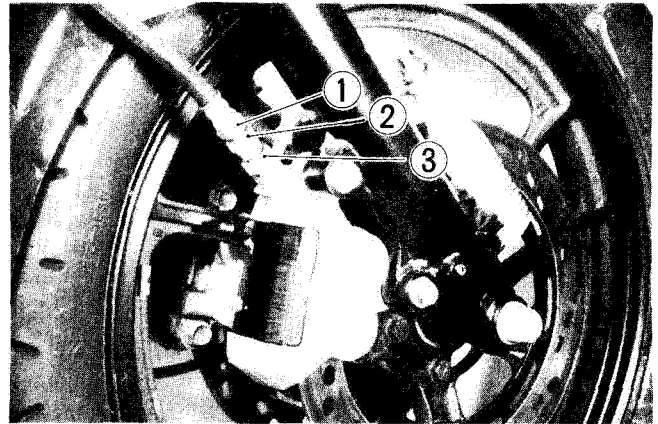

- Remove the O-rings.

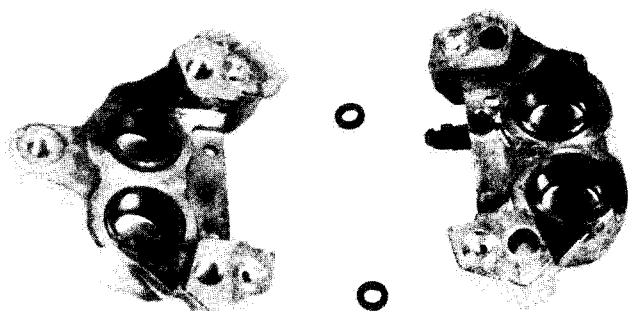

- Push out the pistons by using air gun.

**CAUTION:**

Do not use high pressure air to prevent piston damage.



- Remove the wiper seal, pistons and piston seal from the caliper housing.

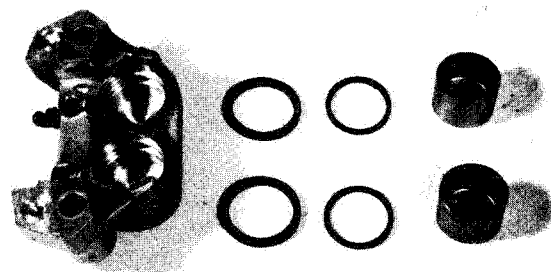

**CALIPER AND DISC INSPECTION**

- Inspect the caliper bore wall for nicks, scratches or other damage.
- Inspect the each rubber part for damage and wear.
- Inspect the piston surface for any scratches or other damage.



- Using a micrometer check the disc for wear. Its thickness can be checked with disc and wheel in place. The service limit for the thickness of the discs are shown below.

09900-20205	Micrometer (0 – 25 mm)
-------------	------------------------

Service Limit	4.0 mm
---------------	--------

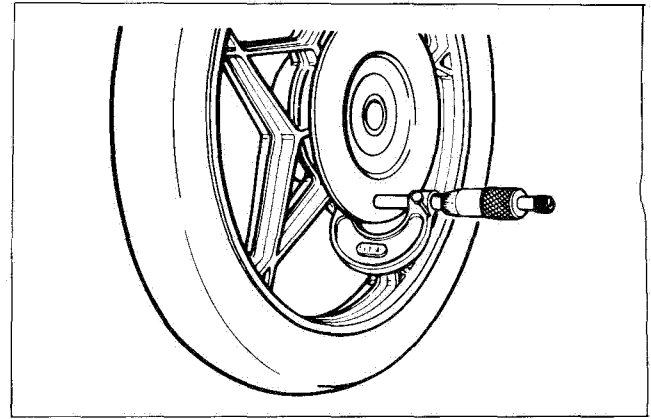

- With the disc mounted on the wheel, check the disc for face runout with a dial gauge, as shown.

09900-20606	Dial gauge (1/100 mm)
09900-20701	Magnetic stand

Service Limit	0.30 mm
---------------	---------

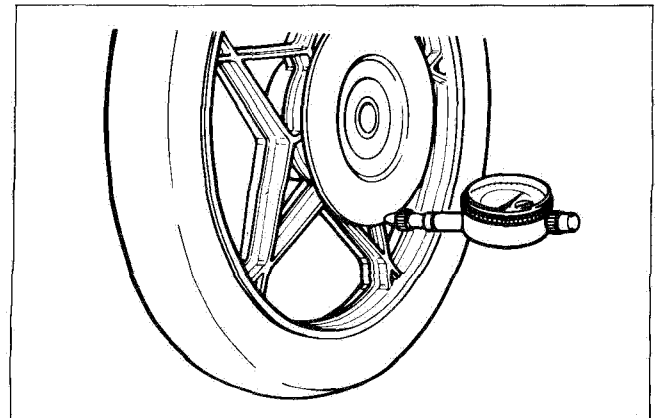

## CALIPER REASSEMBLY

Reassemble the caliper in the reverse orders of disassembly and by taking the following steps:

### CAUTION:

Wash the caliper components with fresh brake fluid before reassembly.

Never use cleaning solvent or gasoline to wash them.

Apply brake fluid to the caliper bore and piston to be inserted into the bore.

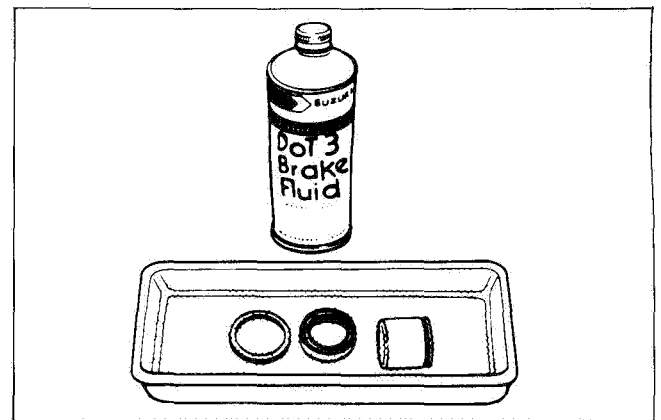

### WARNING:

Bleed the air after reassembling the caliper (See page 2-16)

### Tightening torque

Item	N·m	kg·m
Union bolt	20 – 25	2.0 – 2.5
Caliper mounting bolt	15 – 25	1.5 – 2.5
Caliper housing bolt	30 – 36	3.0 – 3.6

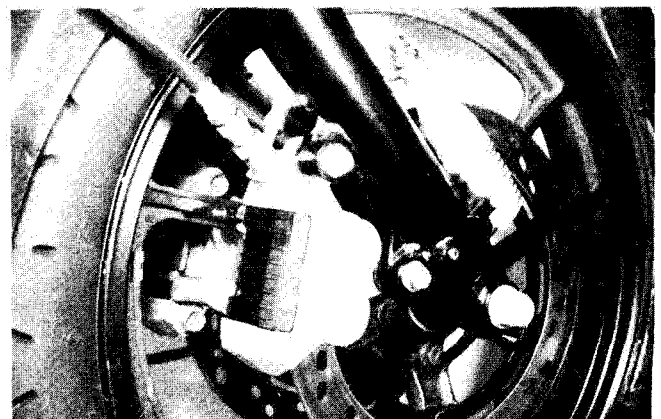

## MASTER CYLINDER REMOVAL AND DISASSEMBLY

- Place a cloth underneath the union bolt on the master cylinder to catch spilled drops of brake fluid. Unscrew the union bolt and disconnect the brake hose/master cylinder joint.

### CAUTION:

Completely wipe off any brake fluid adhering to any part of motorcycle. The fluid reacts chemically with paint, plastics, rubber materials, etc.

- Remove the two clamp bolts and take off the master cylinder assembly.

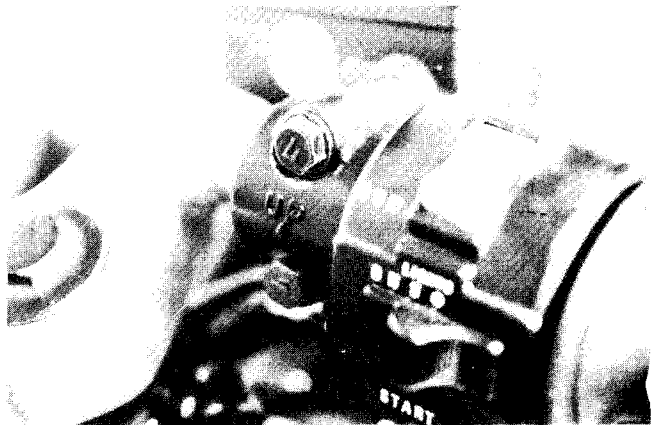
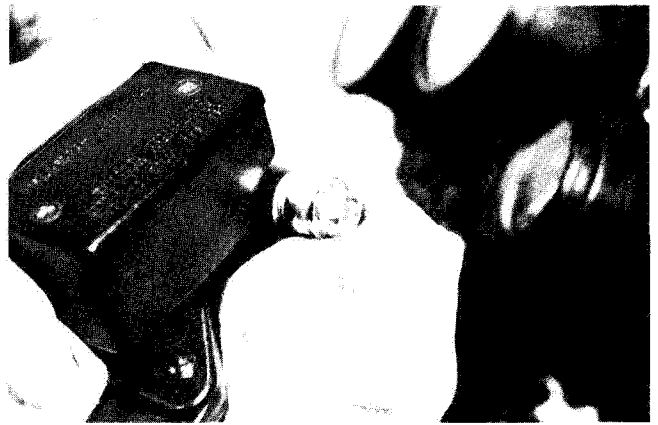

- Remove the front brake lever.
- Take off the front brake light switch.

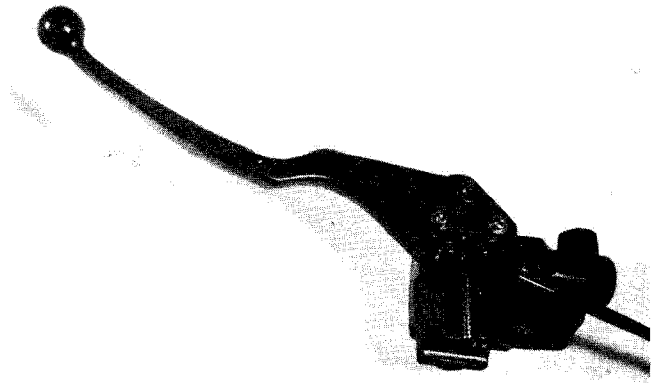

- Remove the reservoir cap and diaphragm.
- Drain brake fluid.



- Pull off the dust boot.
- Remove the circlip by using the special tool.
- Remove the piston, primary cup and spring.

09900-06108	Snap ring pliers
-------------	------------------

- (1) Circlip
- (2) Piston
- (3) Primary cup
- (4) Return spring

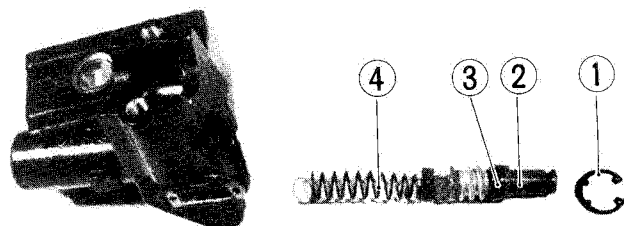
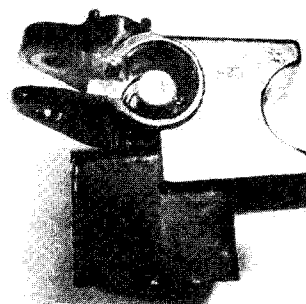

**MASTER CYLINDER INSPECTION**

- Inspect the master cylinder bore for any scratches or other damage.
- Inspect the piston surface for scratches or other damage.
- Inspect the primary cup and dust boot for wear or damage.

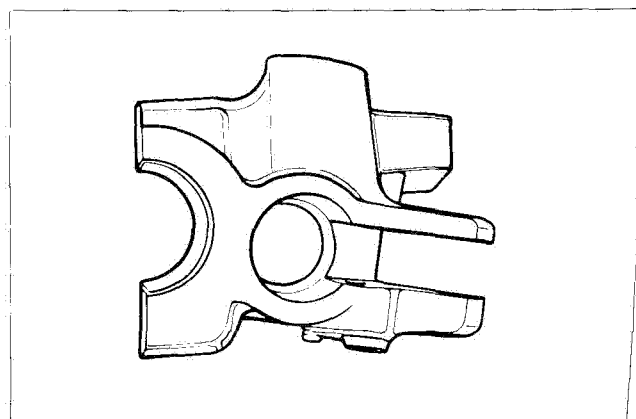

### MASTER CYLINDER REASSEMBLY

Reassemble and remount the master cylinder in the reverse order of disassembly and removal, and also carry out the following steps:

**CAUTION:**

Wash the master cylinder components with fresh brake fluid before reassembly. Never use cleaning solvent or gasoline to wash them. Apply brake fluid to the cylinder bore and all the internals to be inserted into the bore.

When remounting the master cylinder on the handlebars, first tighten the clamp bolt for upside as shown.

**CAUTION:**

Bleed the air after reassembling master cylinder. (See page 2-16).  
Adjust the front brake light switch after installation.

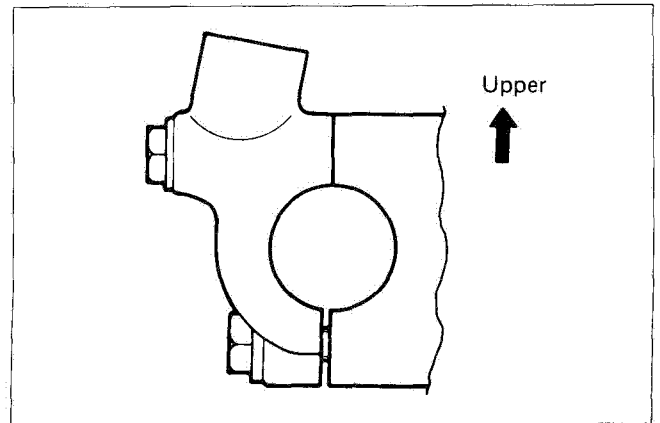

# FRONT FORK

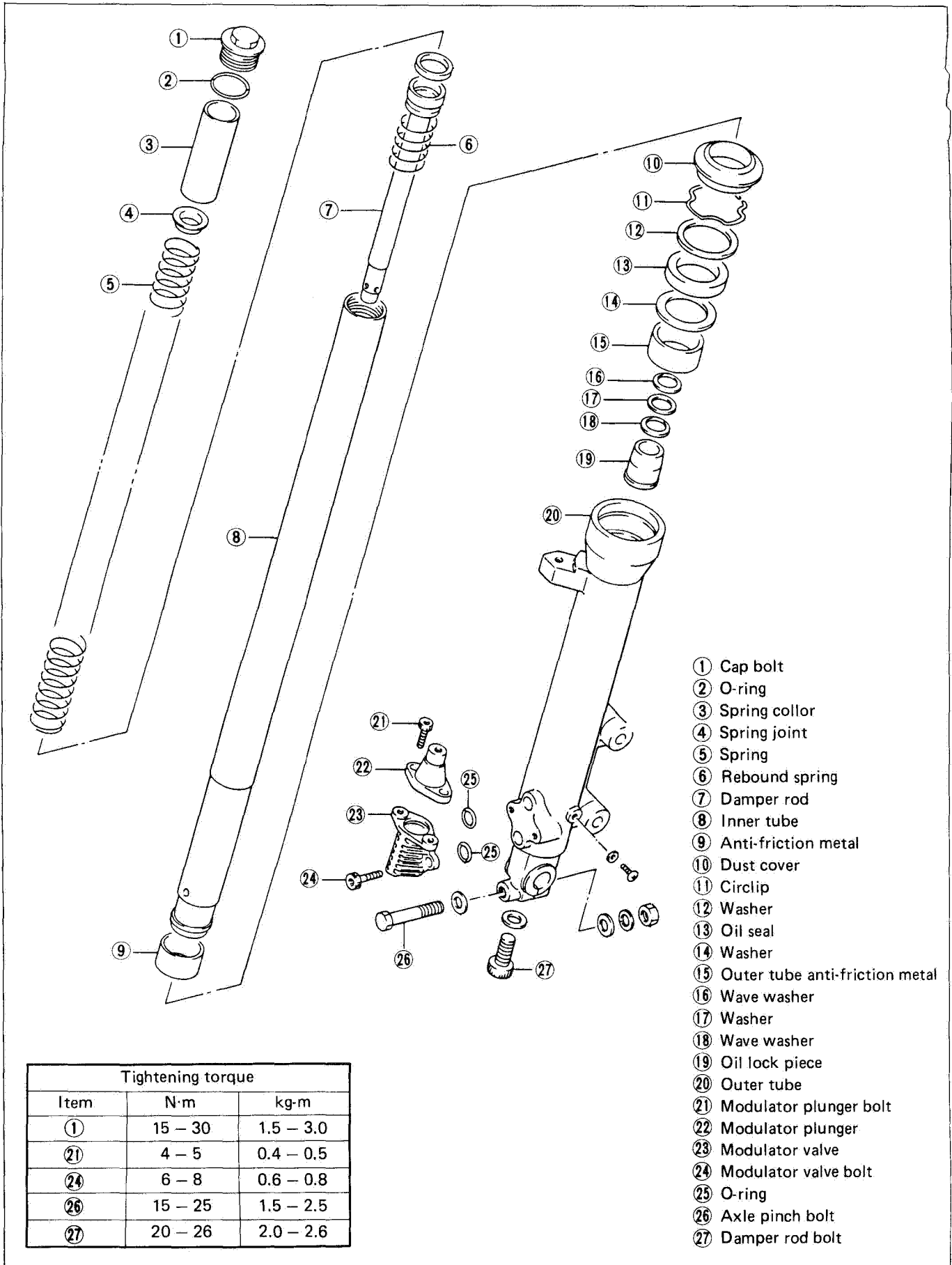

- ① Cap bolt
- ② O-ring
- ③ Spring collar
- ④ Spring joint
- ⑤ Spring
- ⑥ Rebound spring
- ⑦ Damper rod
- ⑧ Inner tube
- ⑨ Anti-friction metal
- ⑩ Dust cover
- ⑪ Circlip
- ⑫ Washer
- ⑬ Oil seal
- ⑭ Washer
- ⑮ Outer tube anti-friction metal
- ⑯ Wave washer
- ⑰ Washer
- ⑱ Wave washer
- ⑲ Oil lock piece
- ⑳ Outer tube
- ㉑ Modulator plunger bolt
- ㉒ Modulator plunger
- ㉓ Modulator valve
- ㉔ Modulator valve bolt
- ㉕ O-ring
- ㉖ Axle pinch bolt
- ㉗ Damper rod bolt

Tightening torque		
Item	N·m	kg·m
①	15 - 30	1.5 - 3.0
㉑	4 - 5	0.4 - 0.5
㉔	6 - 8	0.6 - 0.8
㉖	15 - 25	1.5 - 2.5
㉗	20 - 26	2.0 - 2.6

**REMOVAL**

- Take off the calipers.
- Remove the front wheel (See page 7-3).
- Remove the modulator plunger union bolt.

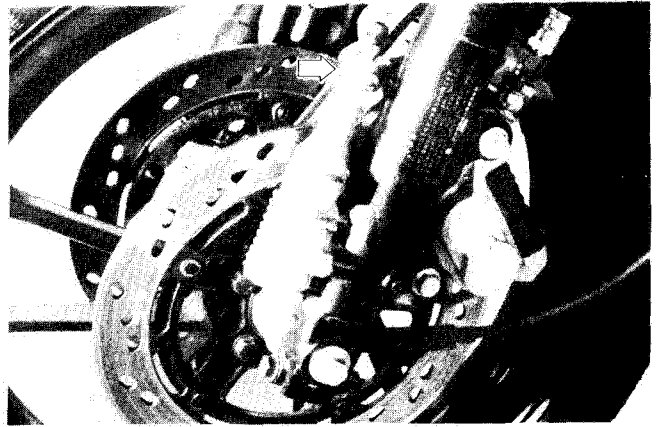

- Remove the fender.

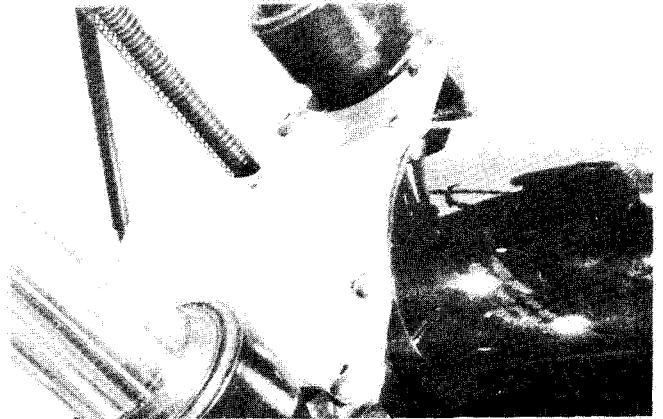

- Remove the handlebar mounting bolts.
- Loosen the upper and lower clamp bolts (right and left).
- Pull off the front fork.

**NOTE:**

When reinstalling the front fork assembly, align the upper surface ① of the inner tube with the upper surface of the handlebar ②.

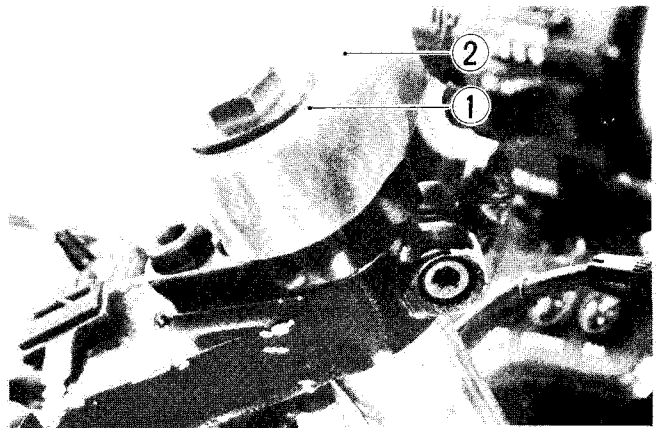
**Tightening torque**

ITEM	N·m	kg-m
Front fork upper clamp bolt	15 – 25	1.5 – 2.5
Front fork lower clamp bolt	15 – 25	1.5 – 2.5
Front fork cap bolt	15 – 30	1.5 – 3.0

**DISASSEMBLY**

- Remove the fork cap and take off the spacer and spring seat.
- Draw out fork spring.



- Invert the fork and stroke it several times to let out fork oil.
- Hold the fork inverted for a few minutes to drain oil.

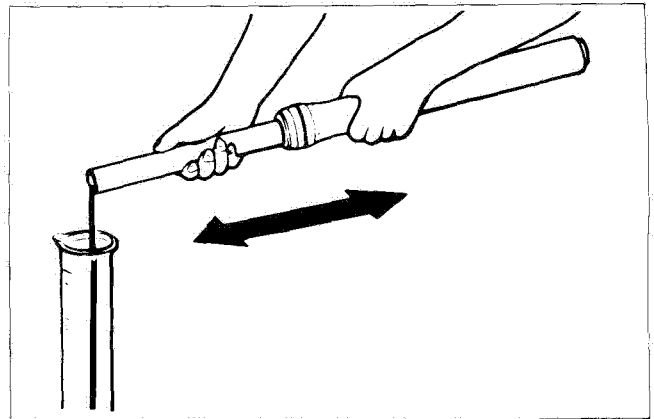

- Remove the damper rod bolt by using the special tools.
- Draw out the damper rod and rebound spring.

09940-34520	"T" handle
09940-34570	Attachment "E"
09914-25811	"T" type hexagon wrench

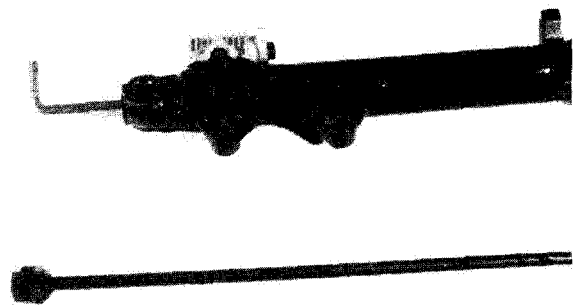

- Draw out the dust seal and circlip.

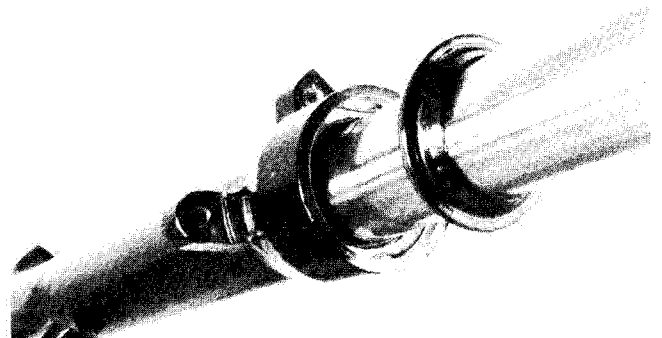

While holding the caliper mounting portion of the outer tube by vise, separate the inner tube from the outer tube as shown.

**CAUTION:**

The outer tube and inner tube anti-friction rings or metal slide rings must be replaced along with the oil seal any time the fork is disassembled.

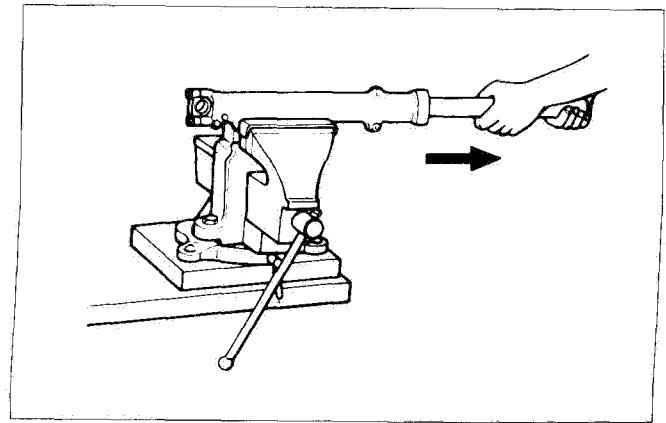

**INSPECTION**

**DAMPER ROD RING**

Inspect the damper rod ring for wear and damage.

**OIL LOCK PIECE**

Inspect the oil lock piece and wave washers for wear and damage.

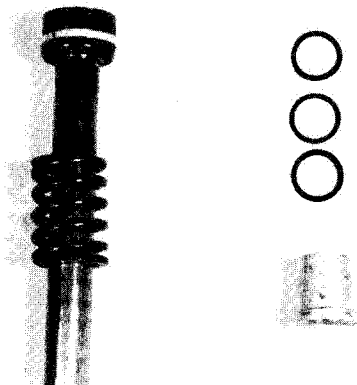

**FORK SPRING**

Measure the fork spring free length. If it is shorter than the service limit, replace it with a new one.

Service Limit	421 mm
---------------	--------

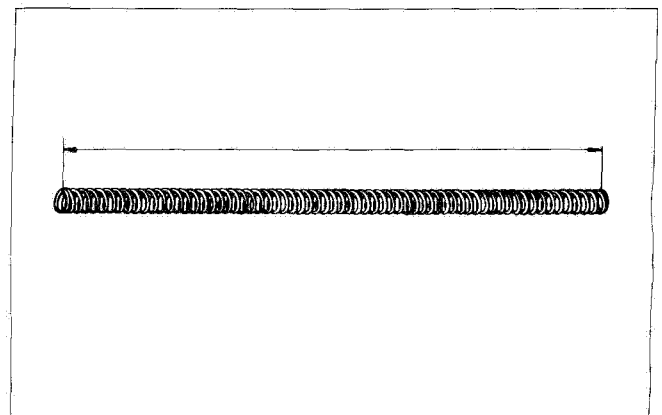

**INNER TUBE**

Inspect the inner tube outer surface for any scuffing.

**OUTER TUBE**

Inspect outer tube and anti-friction metal fitting surface for any scuffing.

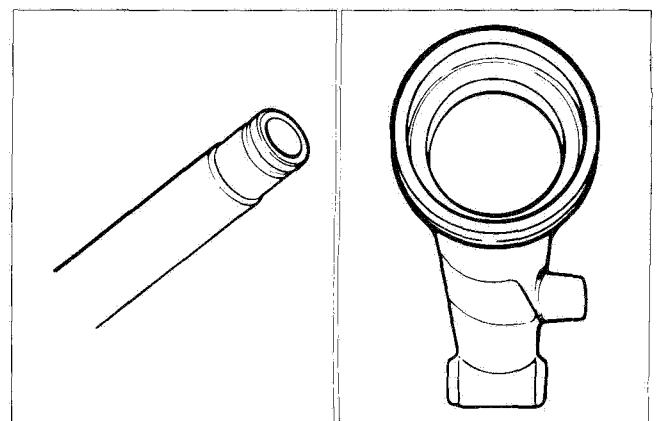



**MODULATOR PLUNGER ASSEMBLY AND VALVE ASSEMBLY**

After separating the modulator plunger from the modulator valve, inspect each sliding part for leakage of brake fluid or fork oil. If any defect is found, replace affected unit with new one.

**NOTE:**  
Modulator plunger or valve is only available as a replacement unit.

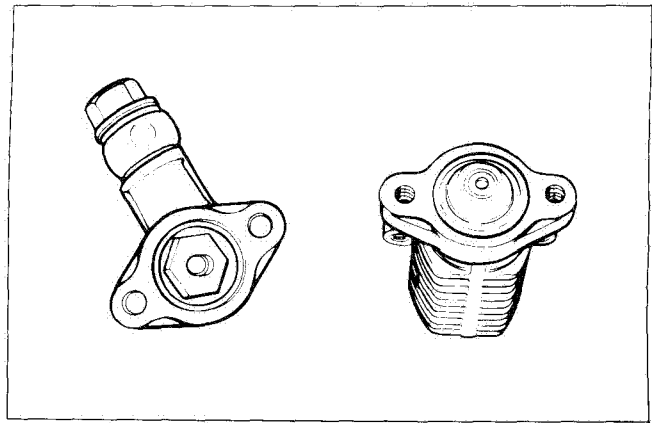

**MODULATOR VALVE O-RINGS**

Inspect the O-rings located between modulator valve and front fork for wear or damage.

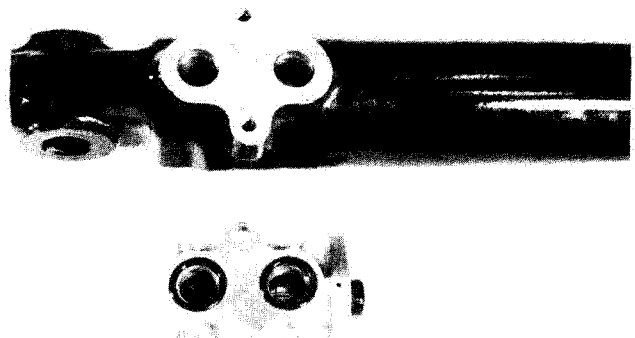

**REASSEMBLY**

Reassemble and remount the front fork in the reverse order of disassembly and removal, and also carry out the following steps:

**DAMPER ROD BOLT**

Apply thread lock "1342" to the damper rod bolt. Tighten the damper rod bolt with specified torque.

99000-32050	Thread Lock "1342"
-------------	--------------------

Tightening torque	20 – 26 N·m (2.0 – 2.6 kg-m)
-------------------	---------------------------------

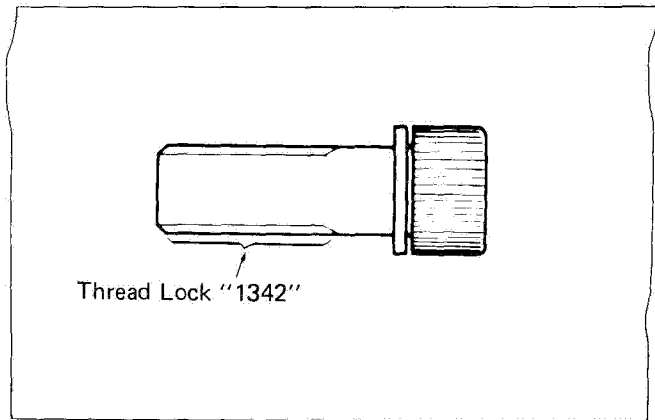

**MODULATOR VALVE**

Apply Thread Lock "1342" to the bolts and tighten them to the specified torque.

99000-32050	Thread Lock "1342"
-------------	--------------------

Tightening torque	6 – 8 N·m (0.6 – 0.8 kg-m)
-------------------	-------------------------------

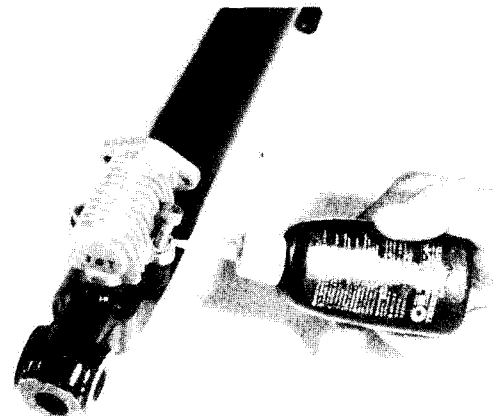

**SPACER AND OIL SEAL**

Clean the metal groove of the outer tube. Oil the anti-friction metal outer surface and clean the spacer and new oil seal surface, and install them to the outer tube as shown.

09940-50112

Front fork oil seal installer

**FORK OIL**

For the fork oil, be sure to use a fork oil whose viscosity rating meets specifications below.

Fork oil type

Fork oil #15

Fork oil capacity

397 ml

Hold the front fork vertical and adjust the fork oil level with the special tool.

**NOTE:**

When adjusting oil level, remove the fork spring and compress the inner tube fully.

09943-74111

Fork oil level gauge

STD oil level

100 mm

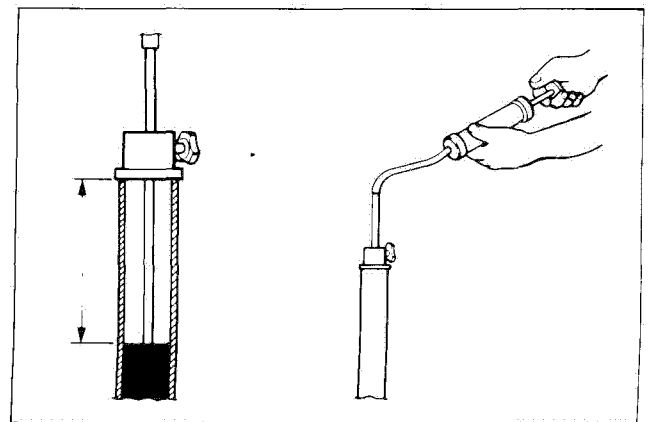
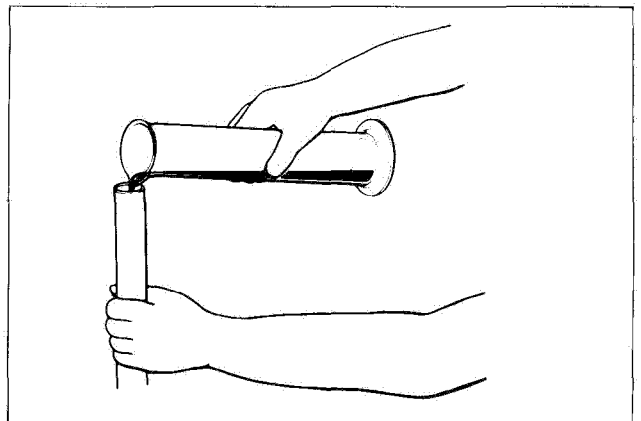
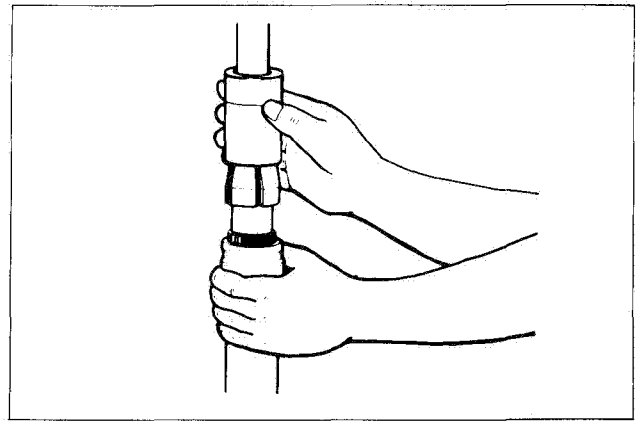
**FORK SPRING**

When installing the fork spring, small pitch end should position in top.

**Tightening torque:**

ITEM	N·m	kg·m
Front fork clamp bolt (Upper)	15 - 25	1.5 - 2.5
Front fork clamp bolt (Lower)	15 - 25	1.5 - 2.5
Damper rod bolt	20 - 26	2.0 - 2.6

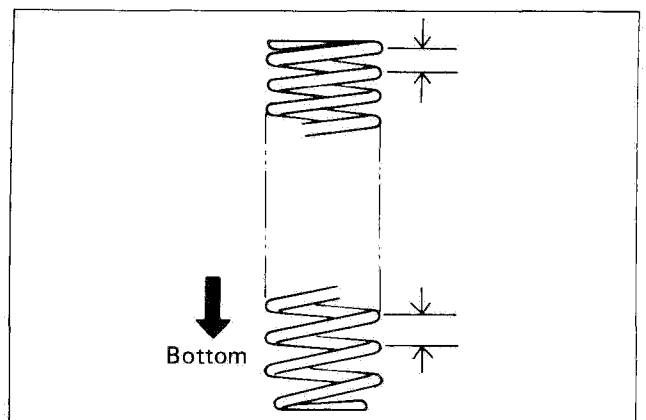

# STEERING STEM

## CONSTRUCTION

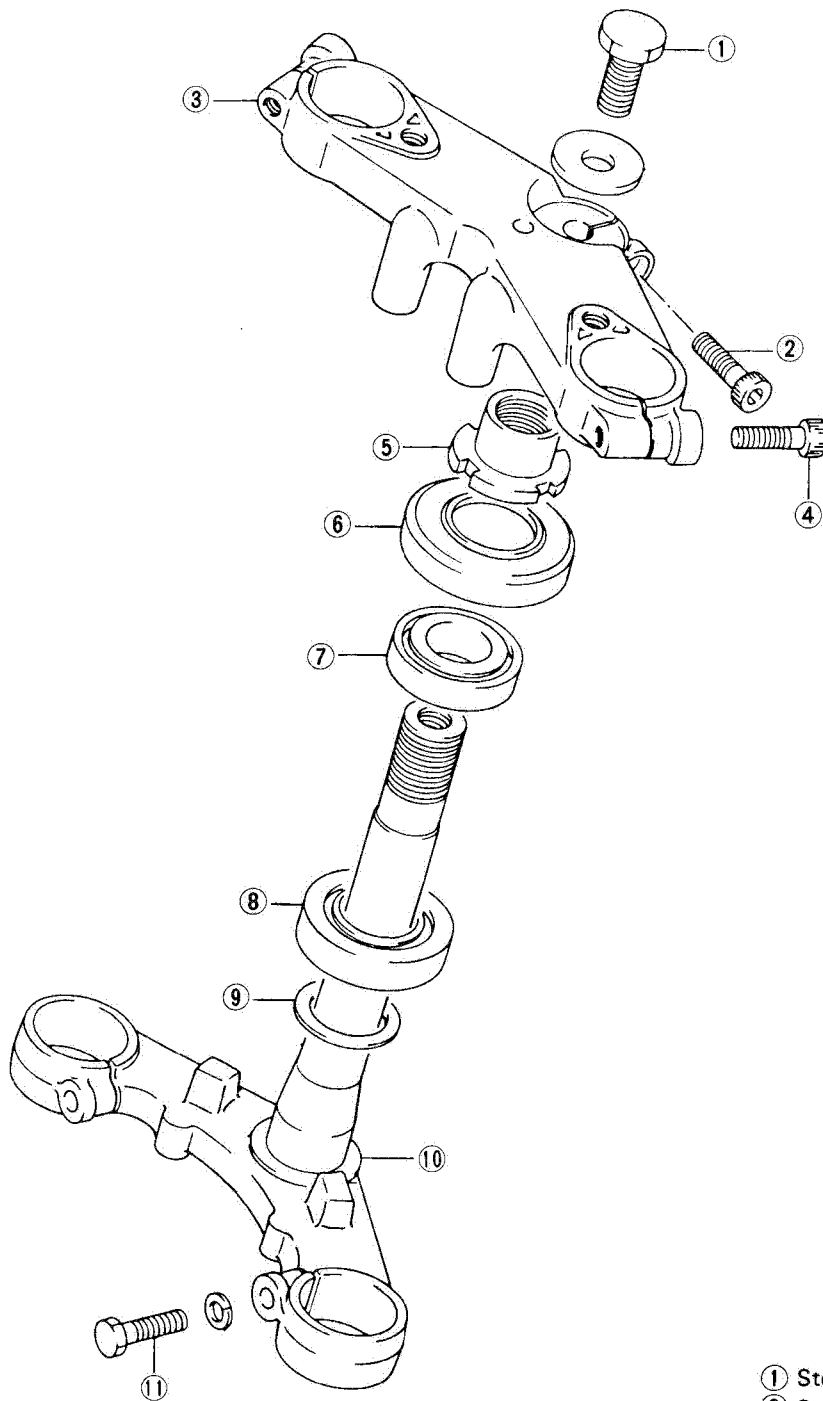

- ① Steering stem head bolt
- ② Steering stem clamp bolt
- ③ Steering stem head
- ④ Front fork upper clamp bolt
- ⑤ Steering stem nut
- ⑥ Dust seal
- ⑦ Steering stem upper bearing
- ⑧ Steering stem lower bearing
- ⑨ Washer
- ⑩ Steering stem
- ⑪ Front fork lower clamp bolt

Tightening torque		
Item	N·m	kg·m
①	20 - 30	2.0 - 3.0
②	15 - 25	1.5 - 2.5
④	15 - 25	1.5 - 2.5
⑪	15 - 25	1.5 - 2.5

## REMOVAL AND DISASSEMBLY

- Remove the fairing (See page 7-1)
- Remove the front wheel (See page 7-3)
- Remove the front fork (See page 7-16)
- Remove the meter assembly mounting screws.

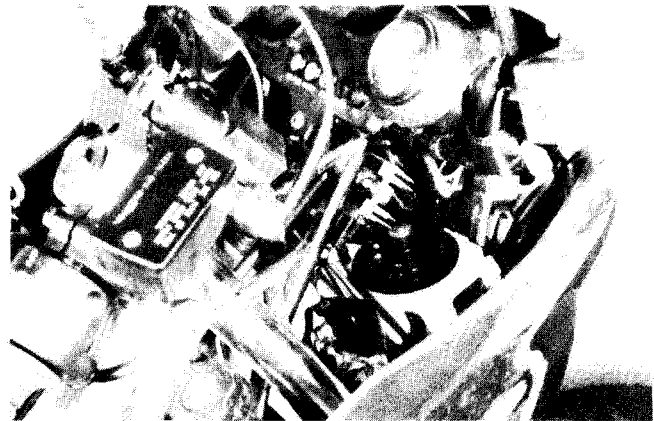

- Disconnect the headlight coupler and unclamp the lead wire.
- Remove the headlight mounting screws and headlight.

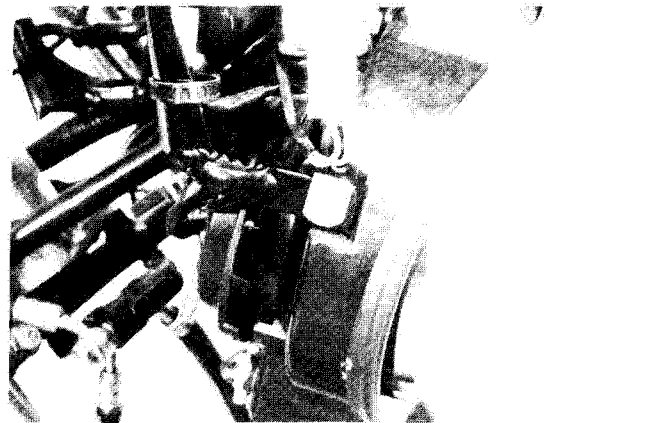

- Disconnect the speedo/tachometer coupler and take off the meter assembly.
- Remove the three bolts and take off the fairing brace.

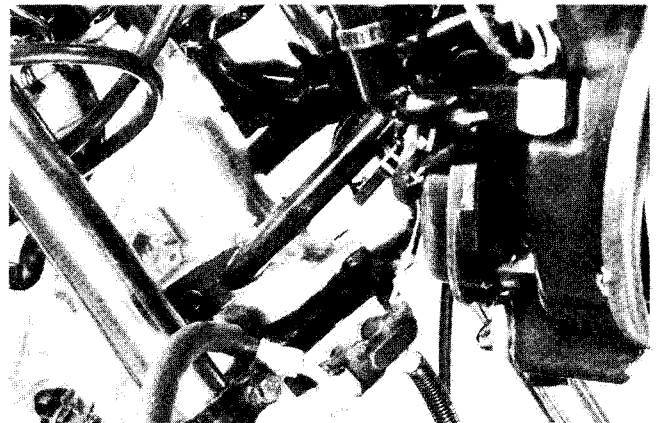

- Remove the steering stem head bolt and loosen the clamp bolt, then take off the steering stem upper bracket.

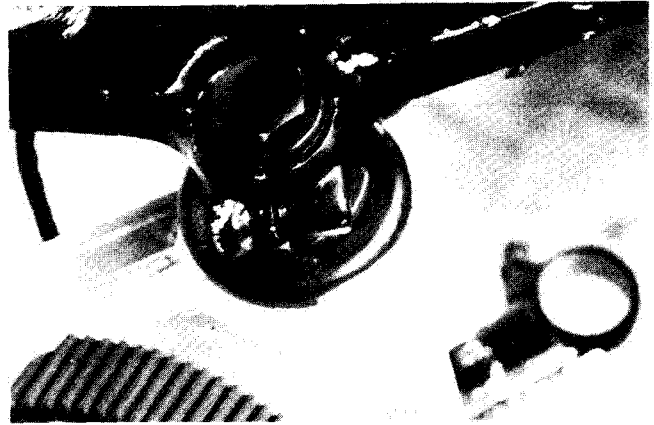

- Disconnect the coupler and remove the ignition switch by using the 5 mm hexagon wrench.

09911-73730

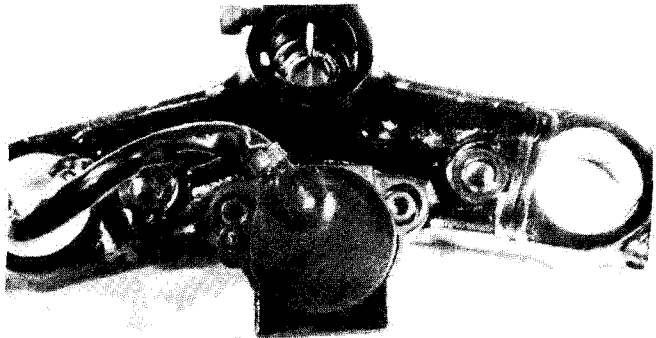
T type hexagon wrench  
(5 mm)

- Remove the steering stem nut by using the special tool, then draw out the steering stem.

09940-14911

Steering stem nut wrench

**NOTE:**

Hold the steering stem lower bracket by hand to prevent it from falling.

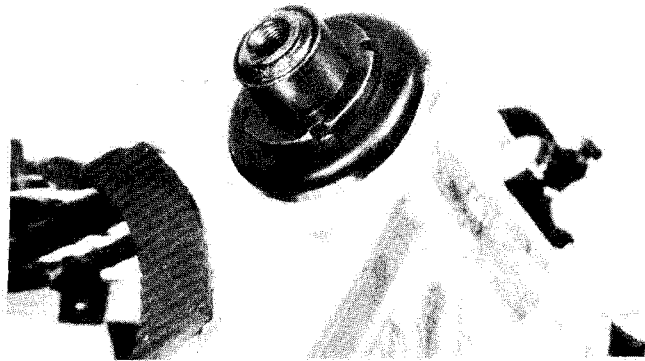

- Draw out the lower steering stem bearing by using the special tool.

**CAUTION:**

The removed bearing should be replaced.

09941-84510

Bearing remover

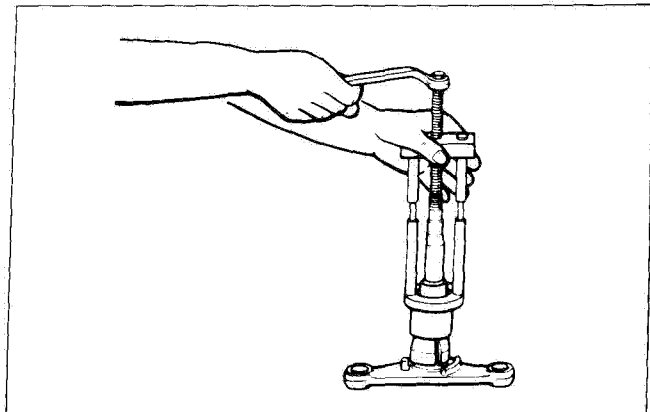

- Push out the steering stem bearing outer races, upper and lower, by using the special tools.

09941-54911	Steering outer race remover
09941-74910	Steering bearing installer

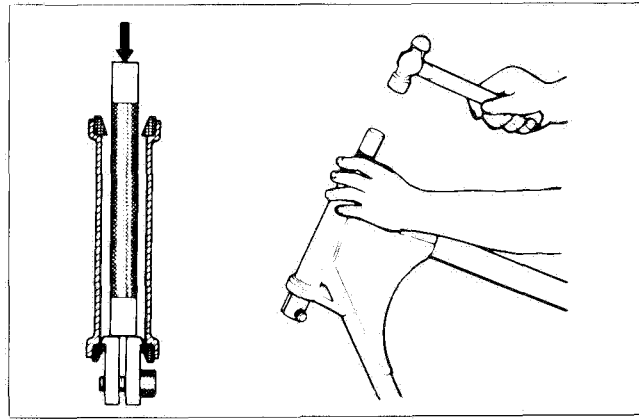

## REASSEMBLY

Reassemble and remount the steering stem in the reverse order of disassembly and removal, and also carry out the following steps:

### OUTER RACES

Press in the upper and lower outer races using the special tool.

09941-34513	Steering outer race installer
-------------	-------------------------------

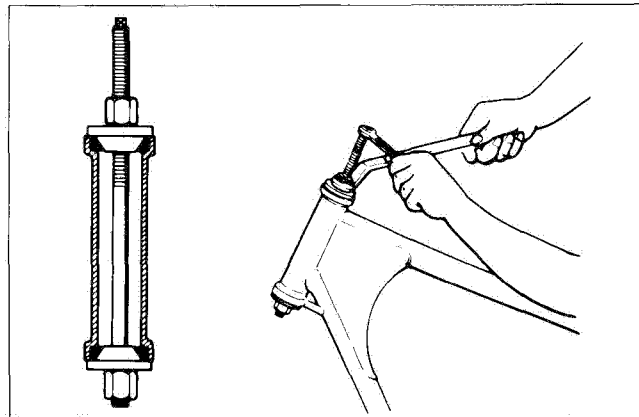

### BEARING

Place a washer and press in the lower bearing by using the special tool.

09941-74910	Steering bearing installer
-------------	----------------------------

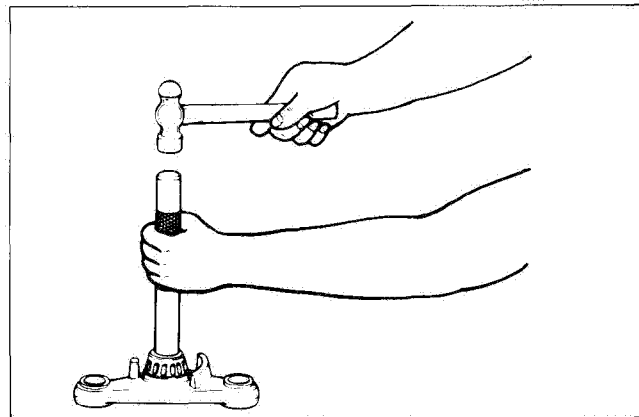

Apply grease to the upper and lower bearing races before remounting the steering stem.

99000-25010	SUZUKI super grease "A"
-------------	-------------------------

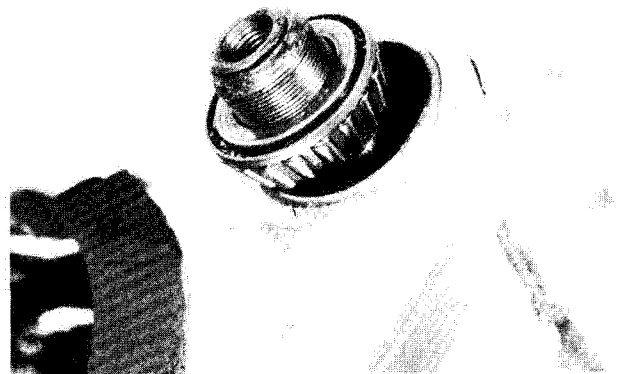

**STEM NUT**

Fit the dust seal to the stem nut.

Tighten the steering stem nut to 40 – 50 N·m (4.0 – 5.0 kg·m).

09940-14911	Steering stem nut wrench
-------------	--------------------------

Turn the steering stem bracket about five or six times to the left and right until it locks in position so that the taper roller bearing will be seated properly.

Turn back the stem nut by  $\frac{1}{4}$  –  $\frac{1}{2}$  turn.

**NOTE:**

This adjustment will vary from motorcycle to motorcycle.

Steering stem head bolt should be tightened to the specified torque.

Tightening torque	20 – 30 N·m (2.0 – 3.0 kg·m)
-------------------	---------------------------------

**CAUTION:**

After performing the adjustment and installing the steering stem upper bracket, "rock" the front wheel assembly forward and back to ensure that there is no play and that the procedure was accomplished correctly. Finally check to be sure that the steering stem moves freely from left to right with own weight. If play or stiffness is noticeable, re-adjust the steering stem nut.

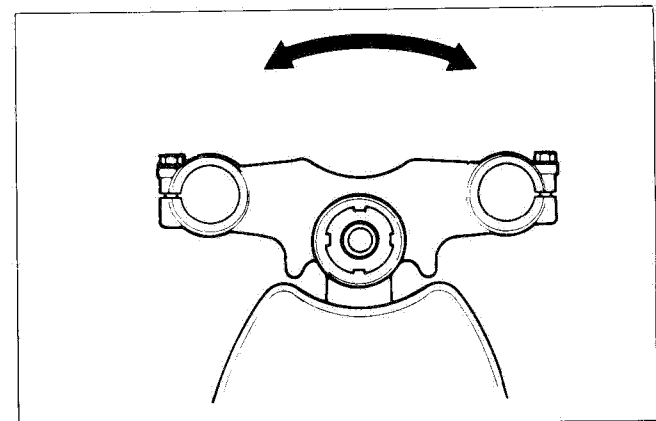
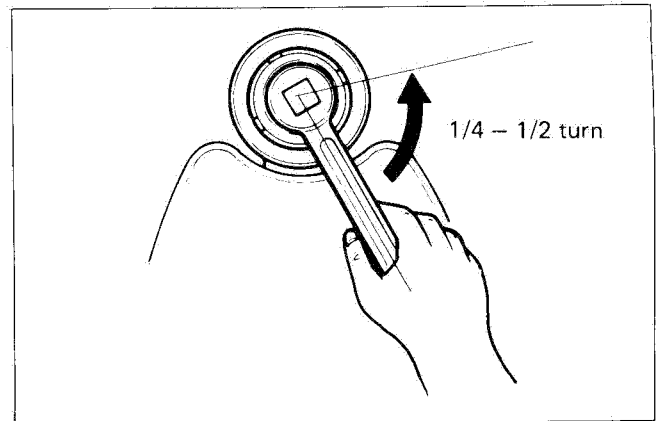
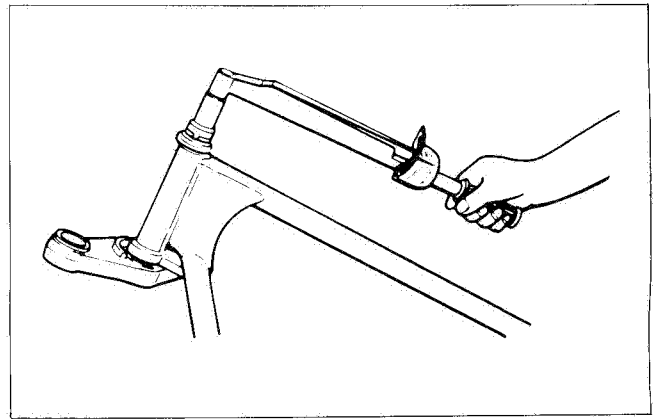

# REAR BRAKE

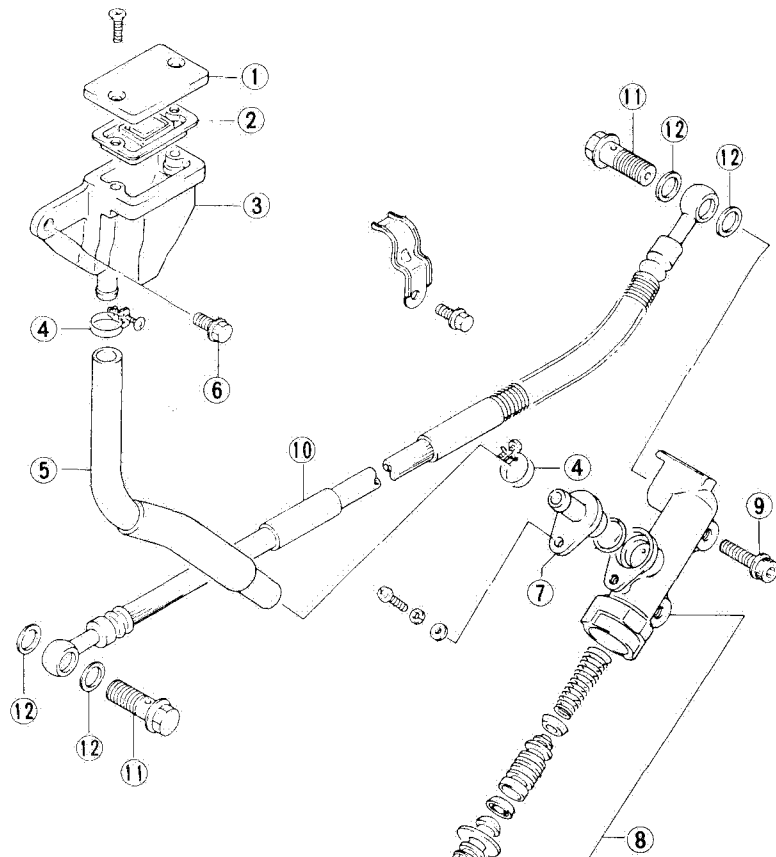

- ① Cap
- ② Diaphragm
- ③ Reservoir tank
- ④ Clip
- ⑤ Reservoir hose
- ⑥ Reservoir tank mounting bolt
- ⑦ Connector
- ⑧ Master cylinder
- ⑨ Mounting bolt
- ⑩ Brake hose
- ⑪ Union bolt
- ⑫ Washer
- ⑬ Cover
- ⑭ Spring
- ⑮ Clip
- ⑯ Pin
- ⑰ Pad
- ⑱ Shim
- ⑲ Dust seal
- ⑳ Piston
- ㉑ Piston seal
- ㉒ O-ring
- ㉓ Housing bolt
- ㉔ Mounting bolt

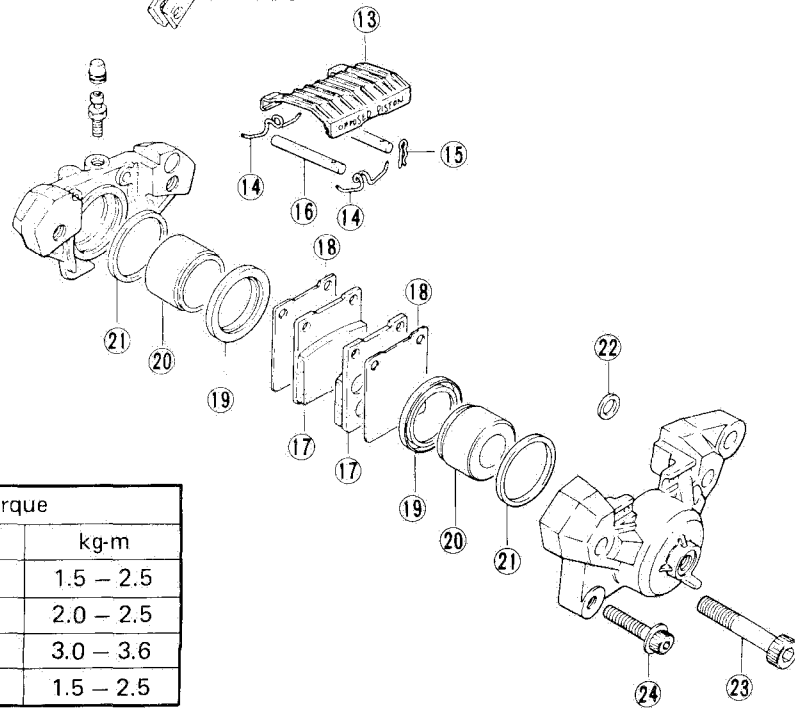

Tightening torque		
Item	N·m	kg·m
⑨	15 - 25	1.5 - 2.5
⑪	20 - 25	2.0 - 2.5
㉓	30 - 36	3.0 - 3.6
㉔	15 - 25	1.5 - 2.5



## BRAKE PAD REPLACEMENT

- Remove the dust cover.
- Pull off the clips.
- Pull off the brake pad hold pins.

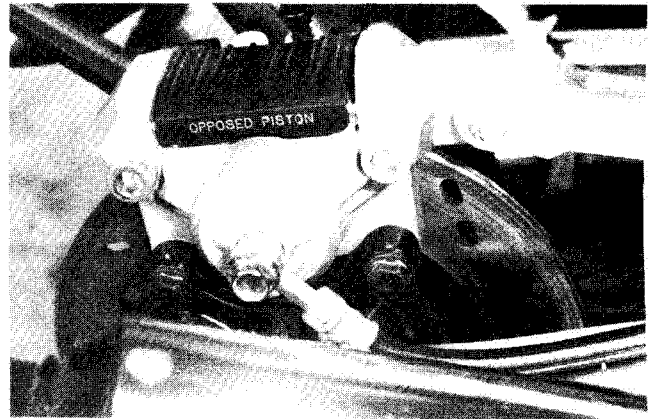

- Take off the brake pads with pad shims.

### NOTE:

Do not operate the brake pedal while taking off the brake pads.

### CAUTION:

Replace the brake pad with a set, otherwise braking performance will be adversely affected.

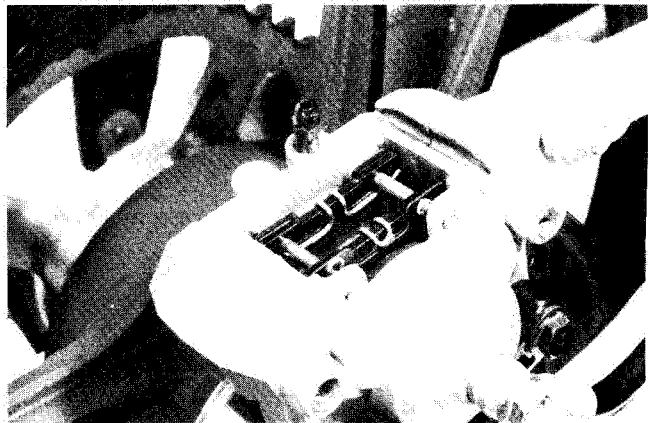

## CALIPER REMOVAL AND DISASSEMBLY

- Remove the union bolt and catch the brake fluid in a suitable receptacle.
- Remove the torque link bolt and nut.
- Remove the caliper mounting bolts and take off the caliper.

### NOTE:

Slightly loosen the caliper housing bolts to facilitate later disassembly before loosening the caliper mounting bolts.

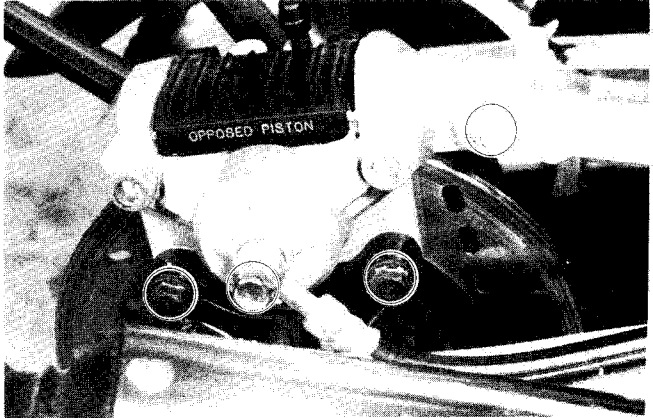

- Remove the caliper housing bolts and separate the caliper halves.

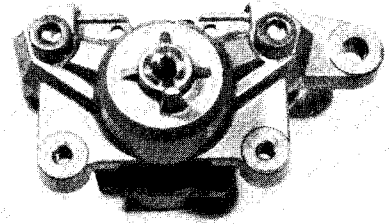

- Place a rag over the piston to prevent it from popping out. Push out the piston by using air gun.

**CAUTION:**

Do not use high pressure air for preventing piston damage.

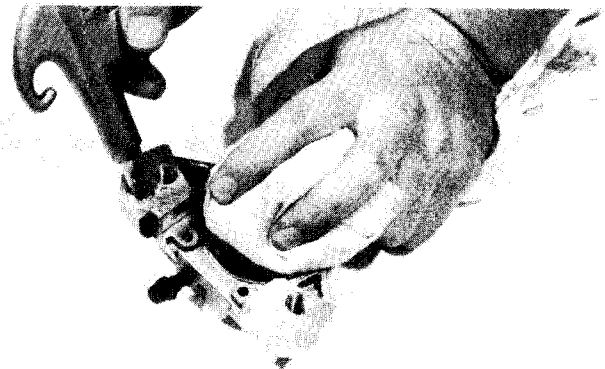

- Remove the piston, O-ring, dust boot and piston seal.

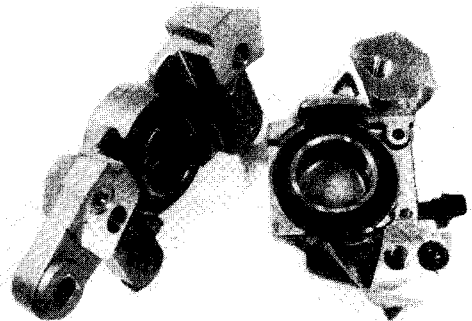

**INSPECTION**

**CYLINDER**

Inspect the cylinder bore wall for nicks, scratches or other damage.

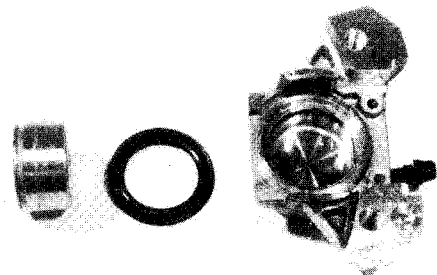

**PISTON**

Inspect the piston surface for any flaws or other damage.

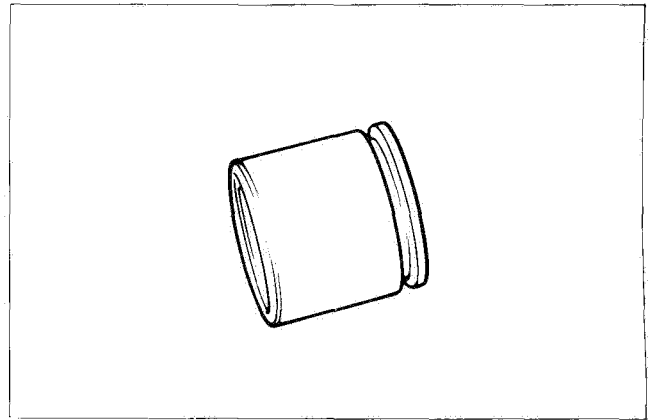

**DUST BOOT AND PISTON SEAL**

Inspect the each rubber part for damage and wear.

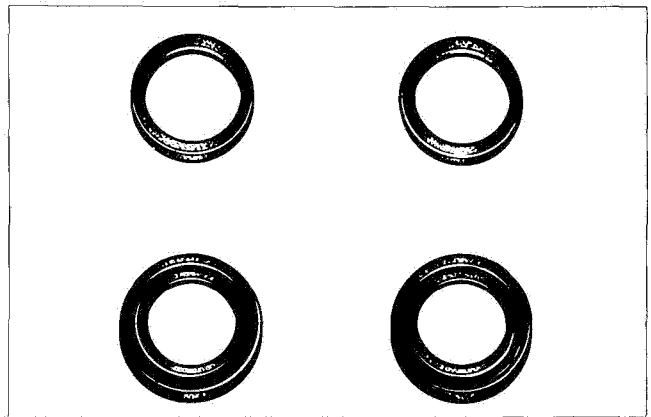

**DISC**

- Measure the disc thickness by using the micrometer.

09900-20205	Micrometer (0 – 25 mm)
-------------	------------------------

Service Limit	6.0 mm
---------------	--------

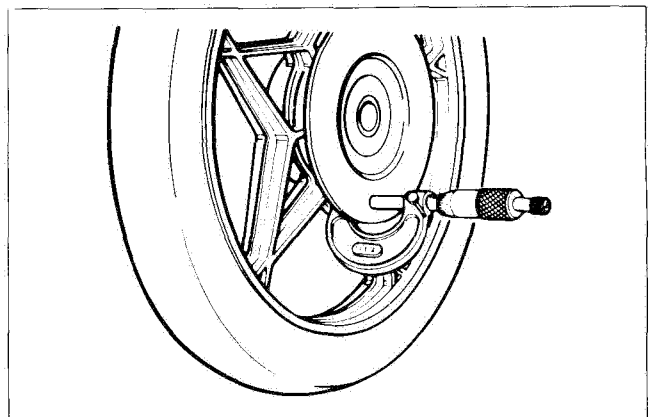

- With the disc mounted on the wheel, check the disc for face runout with a dial gauge, as shown.

09900-20606	Dial guage (1/100)
-------------	--------------------

Service Limit	0.3 mm
---------------	--------

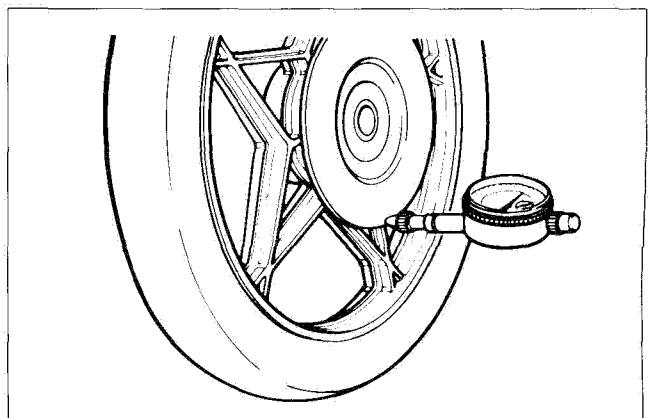

## REASSEMBLY

Reassemble and remount the caliper in the reverse order of disassembly and removal, and also carry out the following steps:

### CAUTION:

- \* Wash the caliper components with fresh brake fluid before reassembly.
- \* Never use cleaning solvent or gasoline to wash them.
- \* Apply brake fluid to the caliper bore and piston to be inserted into the bore.
- \* Bleed the air after reassembling the caliper (See page 2-16).

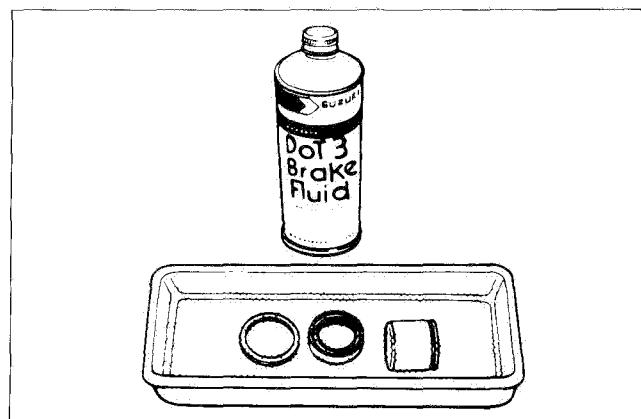

## TIGHTENING TORQUE

Item		N·m	kg·m
Union bolt		20 – 25	2.0 – 2.5
Torque link nut	Front side	10 – 15	1.0 – 1.5
	Rear side	20 – 30	2.0 – 3.0
Caliper housing bolt		30 – 36	3.0 – 3.6
Caliper mounting bolt		15 – 25	1.5 – 2.5

## MASTER CYLINDER REMOVAL

- Remove the brake pedal bolt and take off the brake pedal.

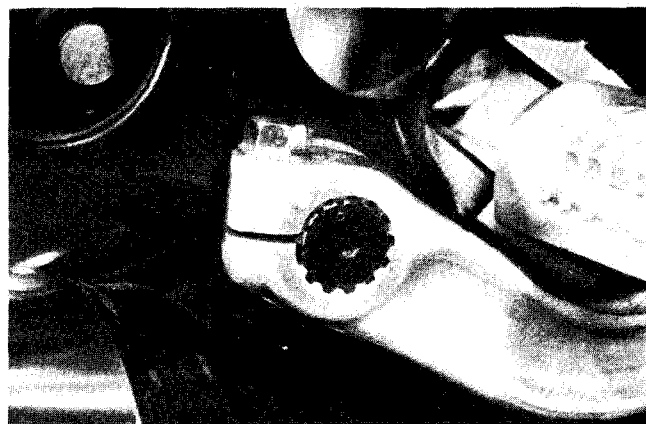

- Remove the bracket.

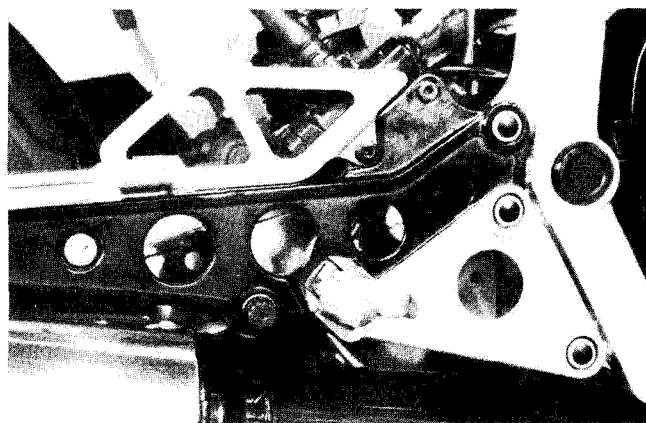

- Remove the union bolt and hose, and catch the brake fluid in a suitable receptacle.

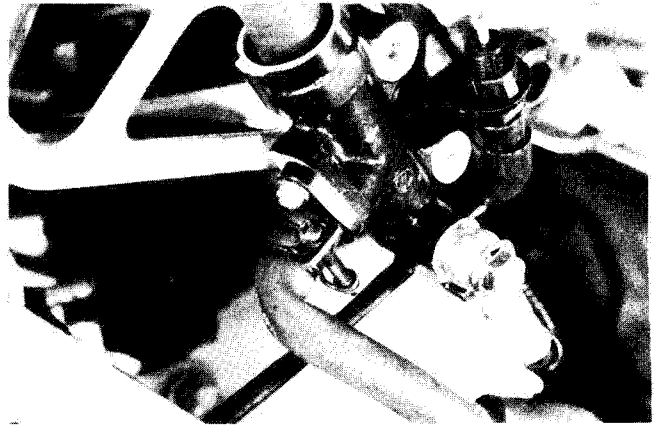

- Pull out the cotter pin ① and take off the pin ②.
- Remove the master cylinder assembly.

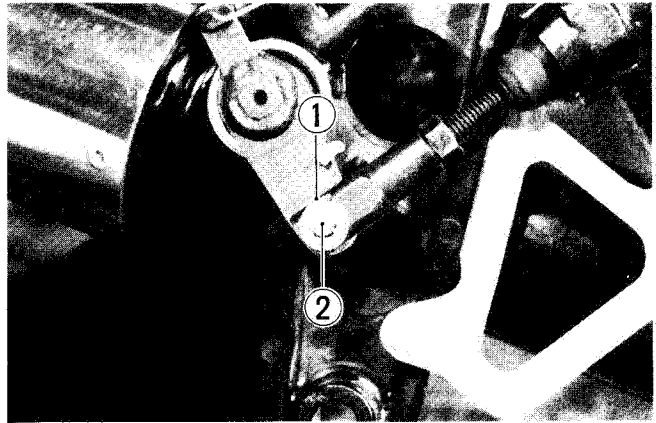

- Remove the circlip by using the special tool.

09900-06105

Snap ring pliers

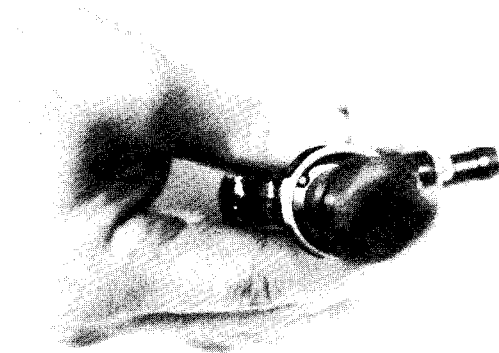

- Remove the rod, piston, primary cup and spring.

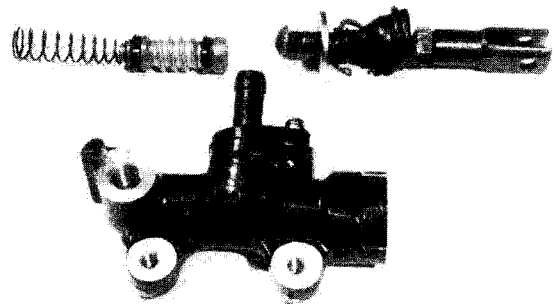

## INSPECTION CYLINDER

Inspect the cylinder bore wall for any scratches or other damage.

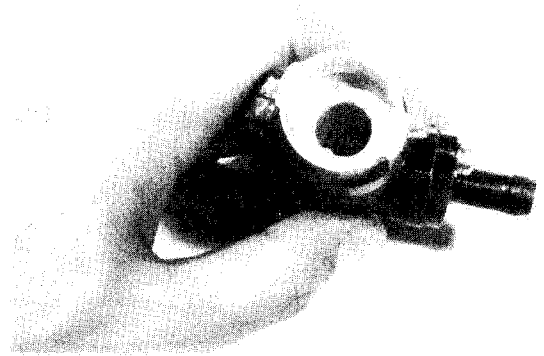

## PISTON AND CUP SET

Inspect the piston surface for scratches or other damage.

Inspect the cup set and each rubber part for damage.

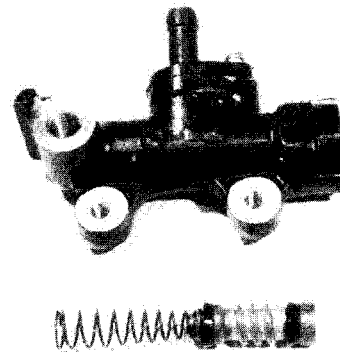

## REASSEMBLY

Reassemble and remount the master cylinder in the reverse order of disassembly and removal, and also carry out the following steps:

### CAUTION:

Wash the master cylinder components with fresh brake fluid before reassembly. Never use cleaning solvent or gasoline to wash them. Apply brake fluid to the cylinder bore and all the internals to be inserted into the bore.

### CAUTION:

Bleed the air after reassembling master cylinder (See page 2-16).  
Adjust the rear brake light switch and brake pedal height after installation.  
(See page 2-15).

## REAR BRAKE PEDAL

When installing the rear brake pedal, align the brake pedal groove with punched mark provided on the end face of the brake pedal rod arm.

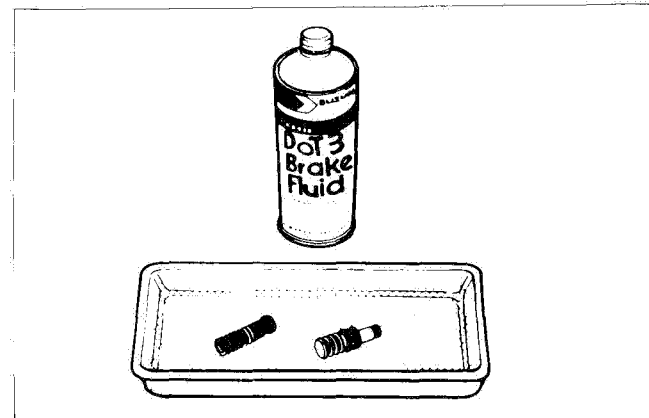

# REAR WHEEL

## CONSTRUCTION

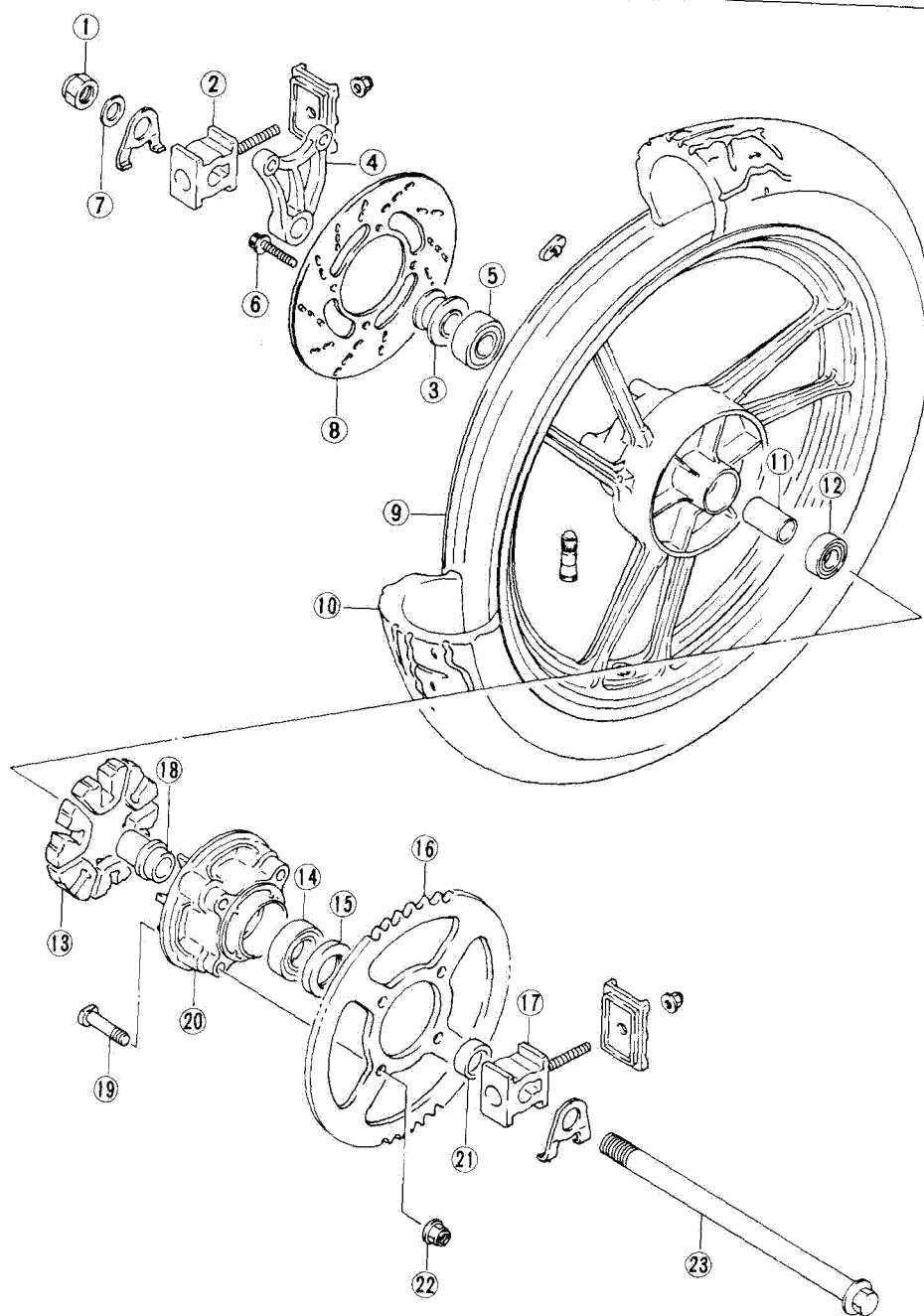

- ① Rear axle nut
- ② Chain adjuster
- ③ Spacer
- ④ Caliper bracket
- ⑤ Bearing
- ⑥ Disc bolt
- ⑦ Washer
- ⑧ Disc plate
- ⑨ Wheel
- ⑩ Tire
- ⑪ Spacer
- ⑫ Bearing
- ⑬ Wheel hub damper
- ⑭ Bearing
- ⑮ Oil seal
- ⑯ Sprocket
- ⑰ Chain adjuster
- ⑱ Spacer
- ⑲ Rear sprocket bolt
- ⑳ Rear sprocket drum
- ㉑ Spacer
- ㉒ Rear sprocket nut
- ㉓ Axle shaft

Tightening torque		
Item	N·m	kg·m
①	50 - 80	5.0 - 8.0
⑥	15 - 25	1.5 - 2.5
㉒	48 - 72	4.8 - 7.2

## REMOVAL AND DISASSEMBLY

- Remove the caliper mounting bolts.



- Remove the axle nut.

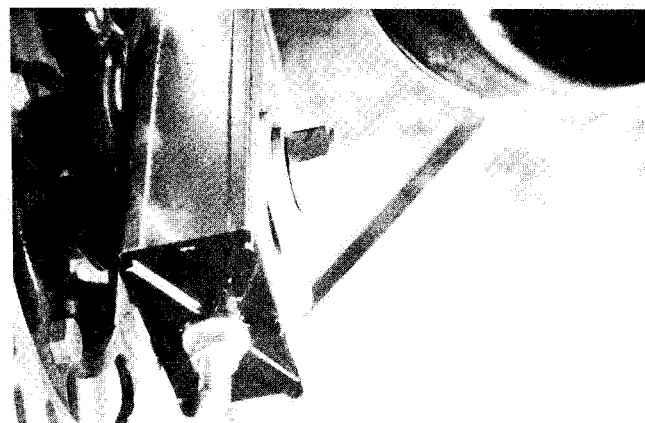

- Draw out the axle shaft and take off the drive chain from the rear sprocket.
- Remove the rear wheel.

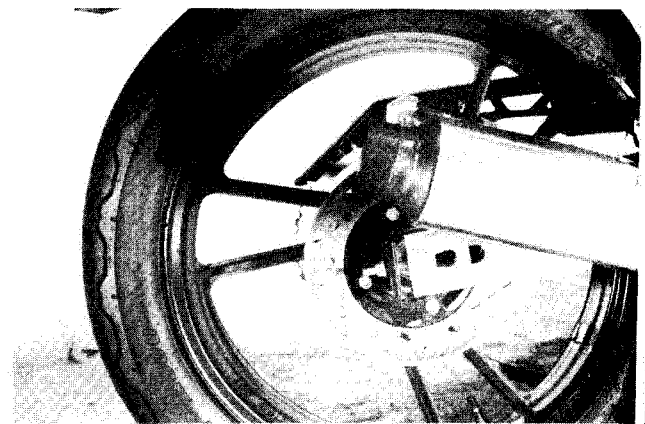

- Draw out the rear sprocket mounting drum from the wheel.

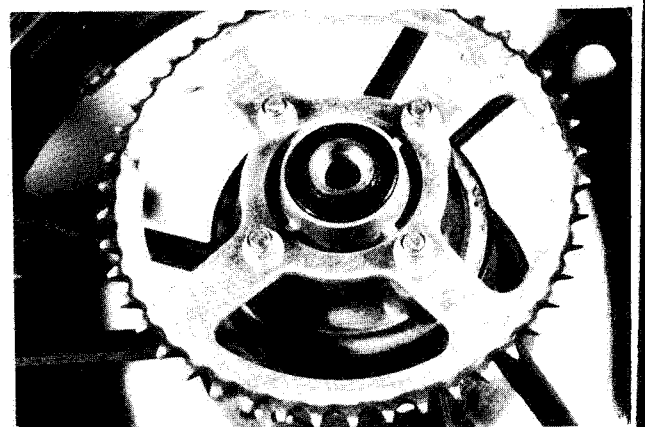



- Remove the six cushions.

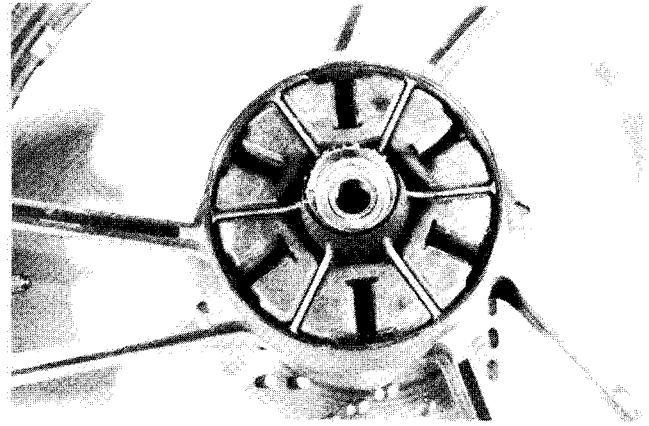

- Remove the bolts and separate the disc from wheel.

**CAUTION:**

Do not reuse the lock washers.

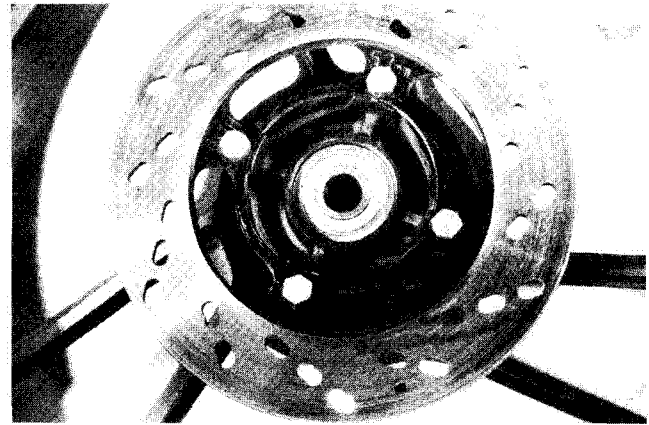

- Drive out wheel bearings, right and left, as well as front wheel bearing. (Refer to page 7-5.)

**CAUTION:**

The removed bearing should be replaced.

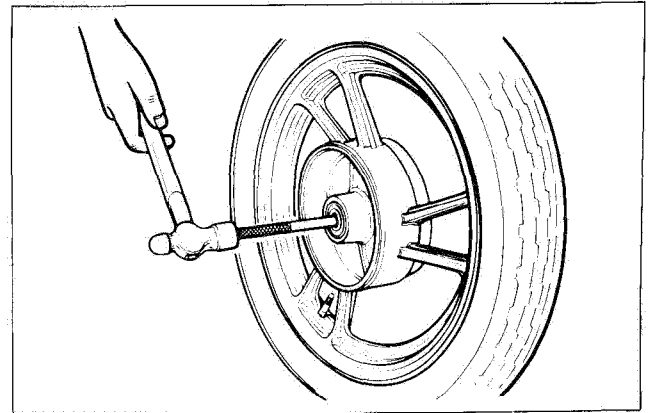

- Remove the four nut.
- Separate the rear sprocket from mounting drum.

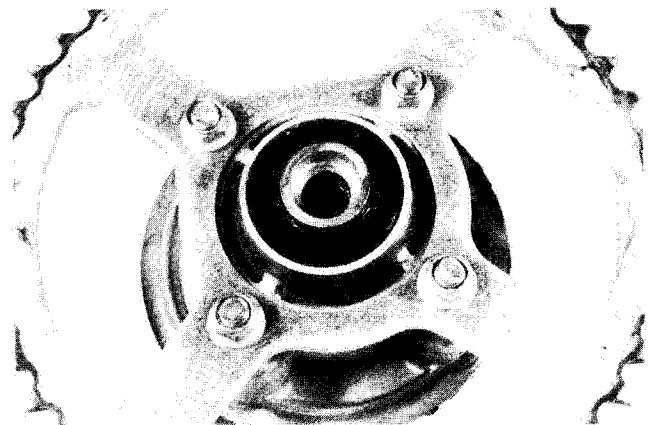

- Remove the oil seal.

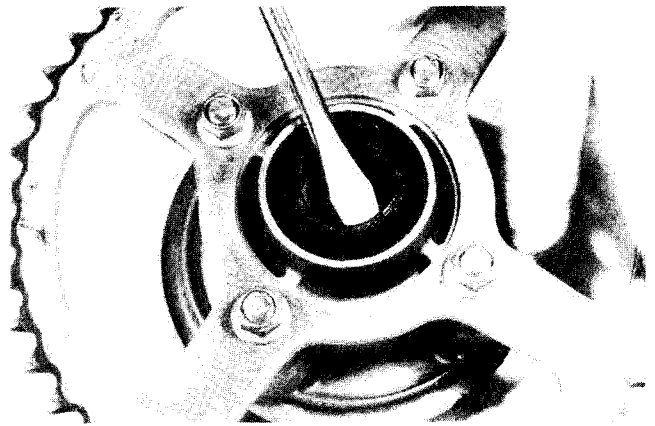

- Drive out the sprocket mounting drum bearings.

**CAUTION:**

The removed bearing should be replaced.

09923-74510	Bearing remover
09930-30102	Sliding shaft

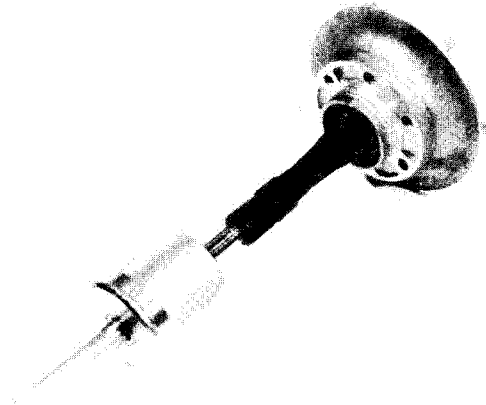
**INSPECTION****REAR WHEEL AND MOUNTING DRUM BEARINGS**

Inspect the play of bearing inner race by hand while it is in the wheel and mounting drum. Rotate the inner race by hand to inspect whether abnormal noise or smooth rotation. Replace the bearing if there is anything unusual.

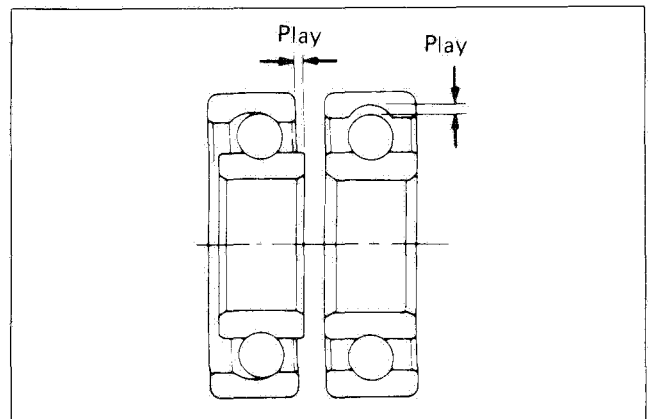
**AXLE SHAFT**

Using a dial gauge, check the axle shaft for runout and replace it if the runout exceeds the limit.

09900-20606	Dial gauge (1/100)
-------------	--------------------

Service Limit	0.25 mm
---------------	---------

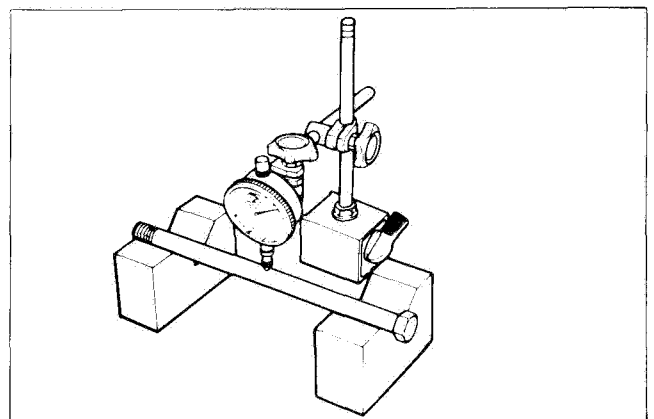

**WHEEL**

Make sure that the wheel runout checked as shown, does not exceed the service limit. An excessive runout is usually due to worn or loose wheel bearings.

If bearing replacement fails to reduce the runout, replace the wheel.

Service Limit (Axial and Radial)	2.0 mm
-------------------------------------	--------

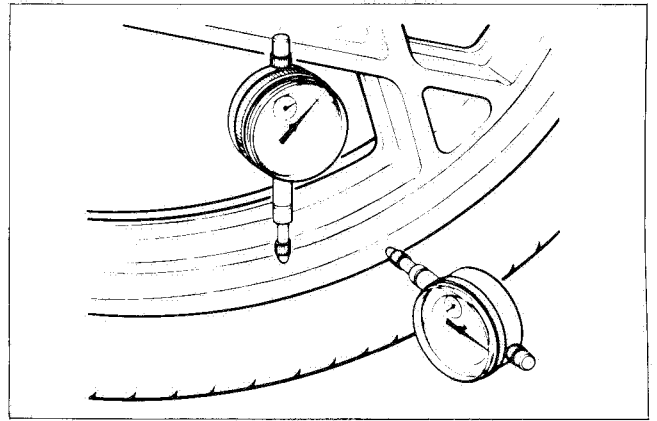
**CUSHION**

Inspect the cushions for wear and damage.

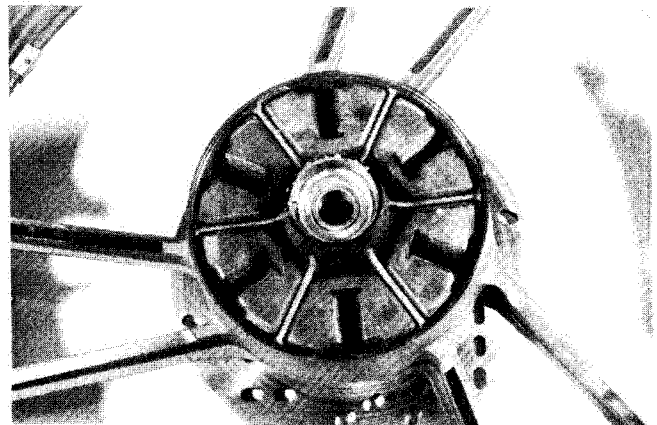
**SPROCKET**

Inspect the sprocket teeth for wear. If they are worn as illustrated, replace the sprocket and drive chain.

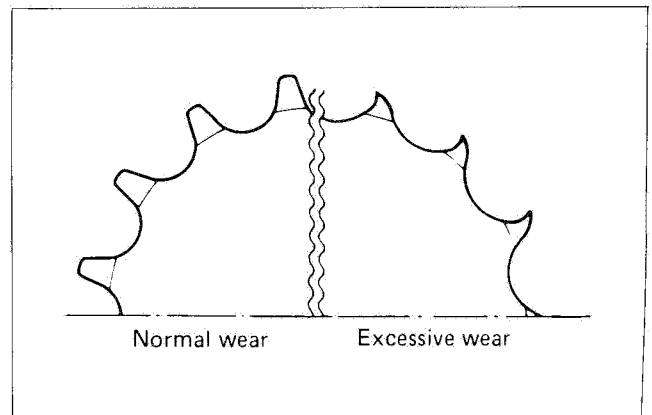

## REASSEMBLY AND REMOUNTING

Reassemble and remount the rear wheel in the reverse order of disassembly and removal, and also carry out the following steps:

### WHEEL BEARINGS

Install the wheel bearings by using the special tools.

09924-84510	Bearing installer set
-------------	-----------------------

**NOTE:**

First install the wheel bearing for right side.

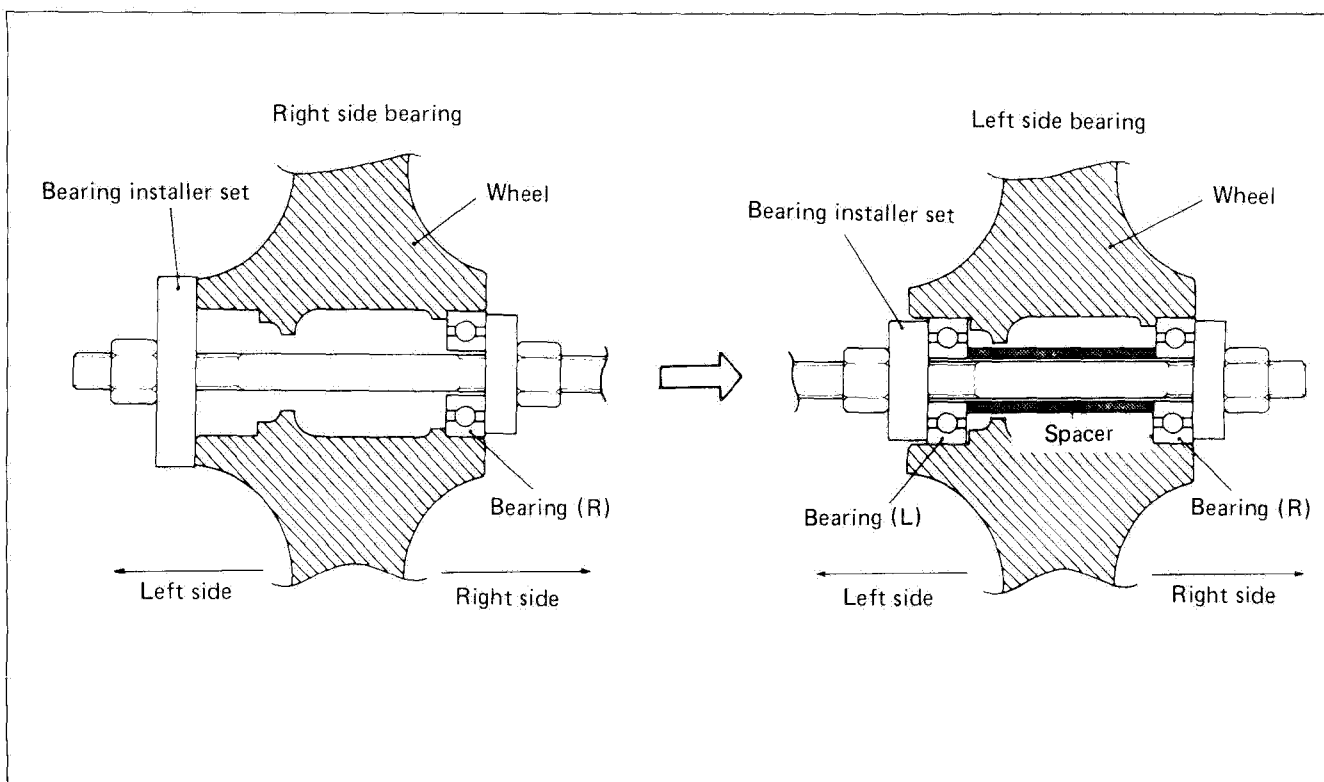
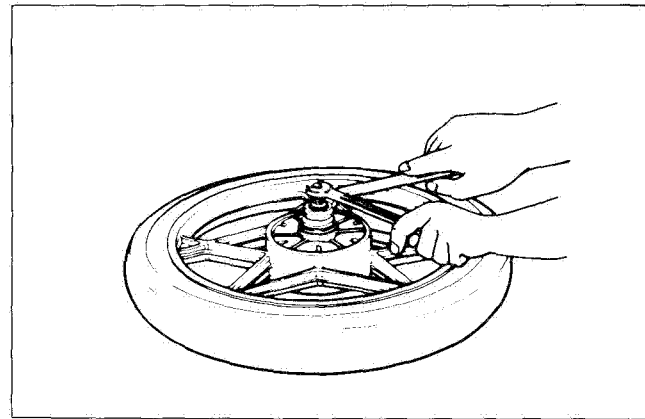

### MOUNTING DRUM BEARING

Install the bearing by using the special tool.

09924-84510	Bearing installer set
-------------	-----------------------

**NOTE:**

Apply grease to the bearing and oil seal lip before assembling rear wheel.

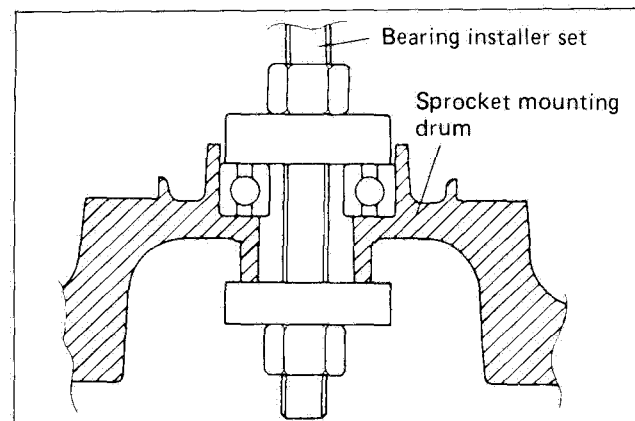

**REAR SPROCKET**

Install the rear sprocket to the mounting drum and tighten the nuts to the specified torque.

Tightening torque	48 – 72 N·m (4.8 – 7.2 kg·m)
-------------------	---------------------------------

**REAR WHEEL ASSEMBLY**

Remount the rear wheel assembly as shown in the illustration.

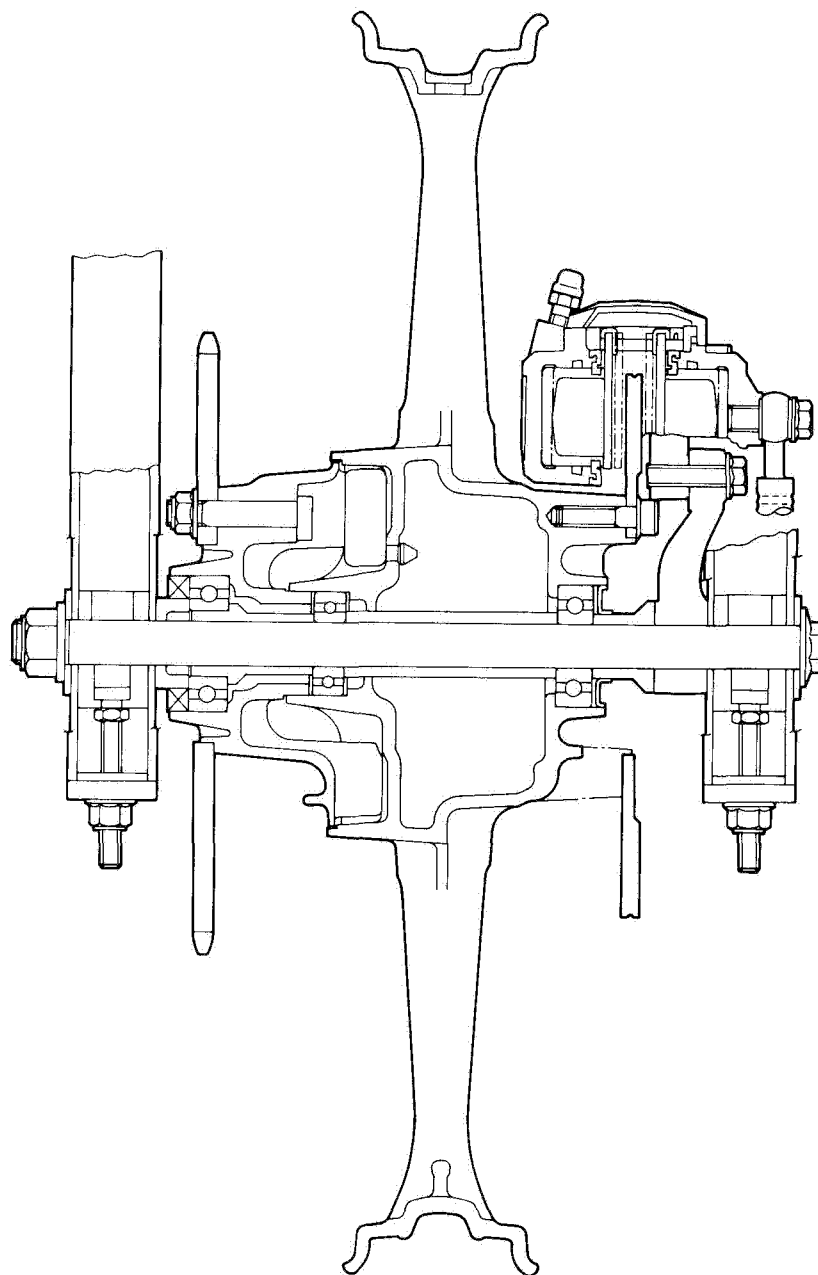

## TIRE AND WHEEL

### REMOVAL

The most critical factor of a tubeless tire is the seal between the wheel rim and the tire bead. Because of this, we recommend using a tire changer which is also more efficient than tire levers.

For tire removal the following tools are required.

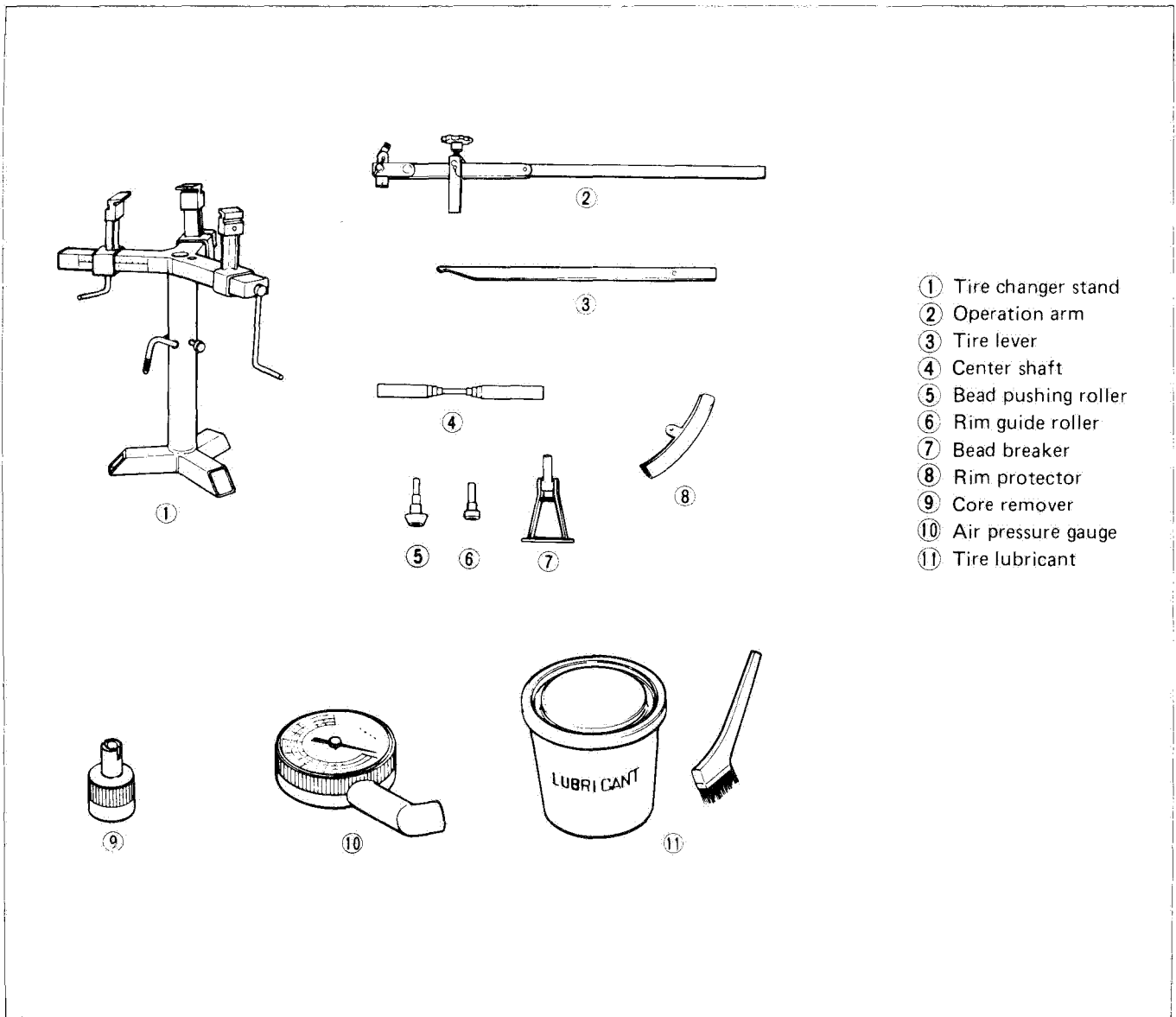

- Remove the valve core from the valve stem, and deflate the tire completely.

#### NOTE:

Mark tire with chalk to note the position ① of the tire on the rim and rotational direction ② of the tire.

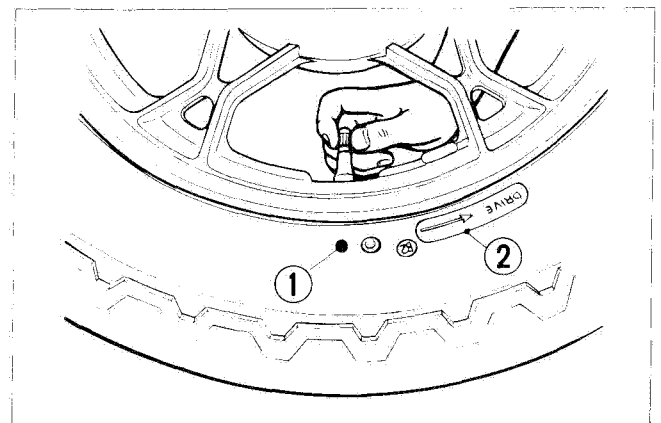

- Place the center shaft ① to the wheel, and fix the wheel firm by the rim holder ②.

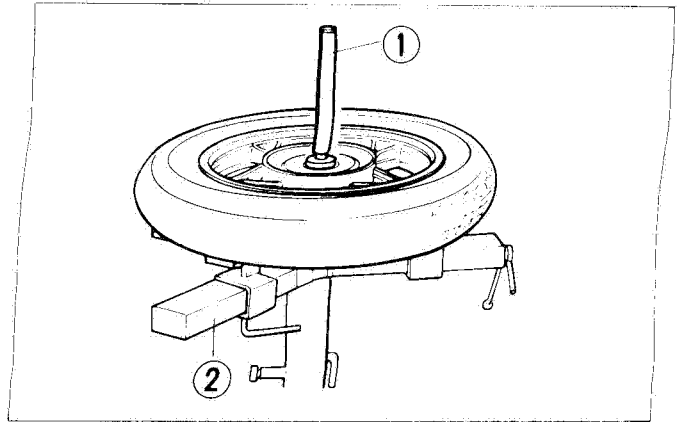

- Attach the operation arm ③ to the center shaft.

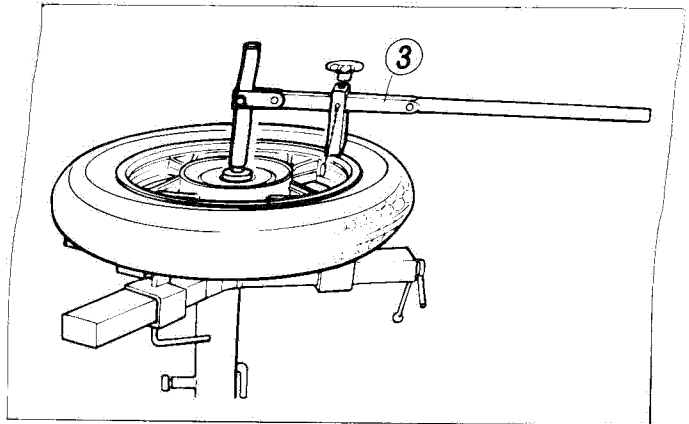

- Attach the bead breaker ④ to the operation arm, and dismount the bead from the rim. Turn the wheel over and dismount the other bead from the rim.

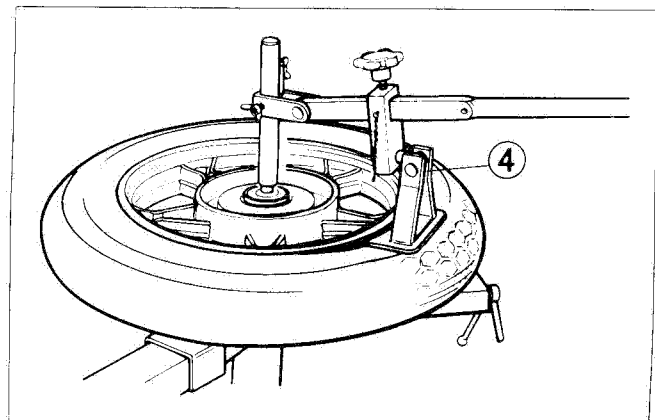

- Install the rim guide roller ⑤.
- Install the rim protector ⑥, and raise the tire bead with the tire lever ⑦.

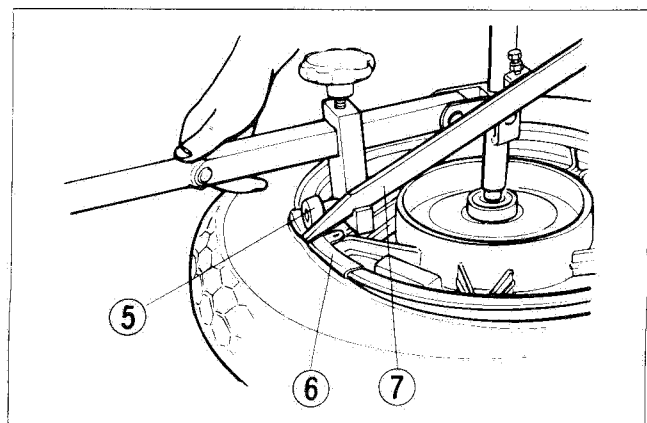

- Set the tire lever against the operation arm, and rotate the lever around the rim. Repeat this procedure to remove the other bead from the rim.

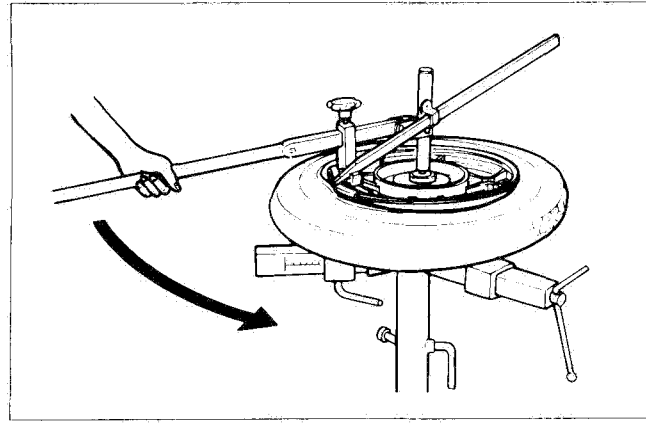

## INSPECTION

### WHEEL

Wipe off any rubber substance or rust from the wheel, and inspect the wheel rim. If any one of the following items is observed, replace it with a new wheel.

- \* A distortion or crack.
- \* Any scratches or flaws in the bead seating area.
- \* Wheel runout (Axial & Radial) of more than 2.0 mm.

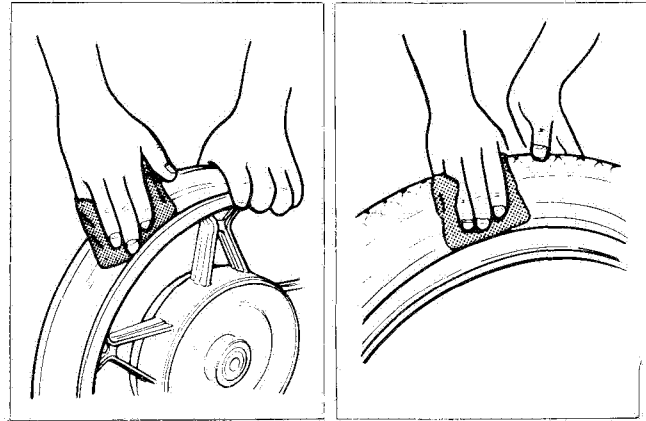

### TIRE

Thoroughly inspect the removed tire, and if any one of the following items is observed, do not repair the tire. Replace with the new one.

- \* A puncture or a split whose total length or diameter exceeds 6 mm.
- \* A scratch or split at the side wall.
- \* Tread depth less than 1.6 mm in the front tire and less than 2.0 mm in the rear tire.
- \* Ply separation.
- \* Tread separation.
- \* Tread wear is extraordinarily deformed or distributed around the tire.
- \* Scratches at the bead.
- \* Cord is cut.
- \* Damage from skidding (flat spots).
- \* Abnormality in the inner liner.

## REPAIR

### NOTE:

When repairing a flat tire, follow the repair instructions and use only recommended repairing materials.



## VALVE

### INSPECTION

Inspect the valve after the tire is removed from the rim, and replace with the new valve if the seal rubber has any split or scratch.

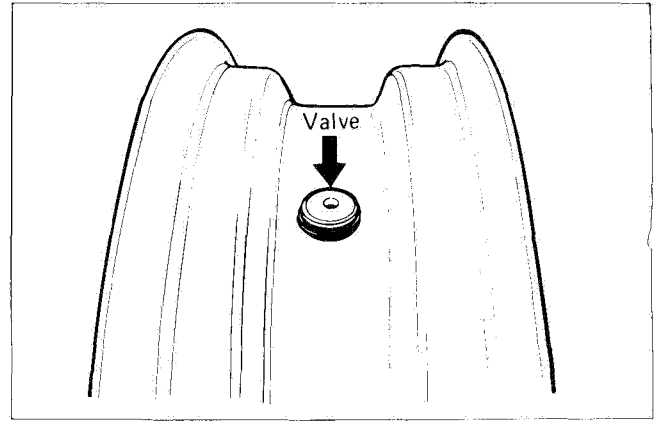

Inspect the removed valve core and replace with the new one if seal rubber is abnormally deformed or worn.

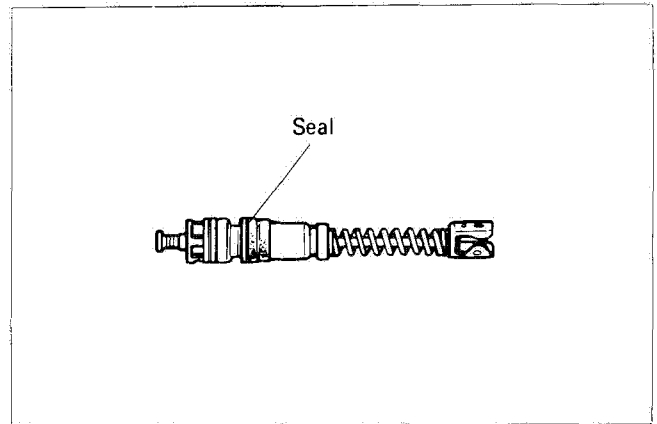

### INSTALLATION

Any dust or rust around the valve hole must be cleaned off. Then install the valve in the rim.

#### CAUTION:

When installing the valve, tighten the nut ① by hand as much as possible. Holding the nut under this condition, tighten the lock nut ②. Do not overtighten nut ① as this may distort the rubber packing and cause an air leak.

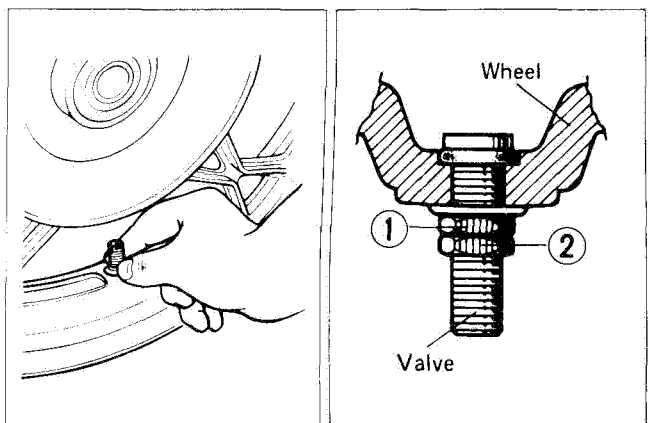
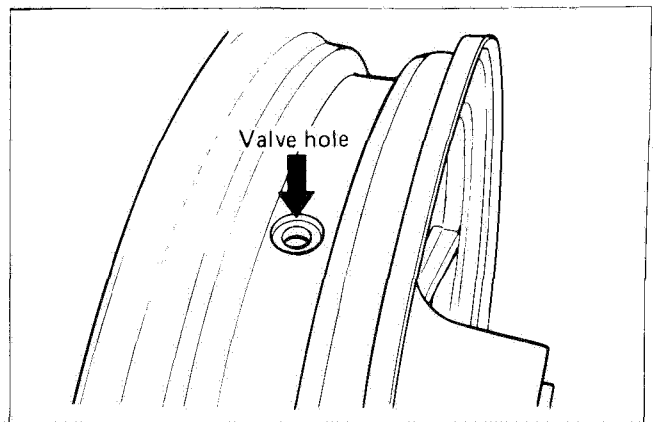

## TIRE MOUNTING

- Apply a special tire lubricant or neutral soapy liquid to the tire bead.

### CAUTION:

Never apply grease, oil or gasoline.

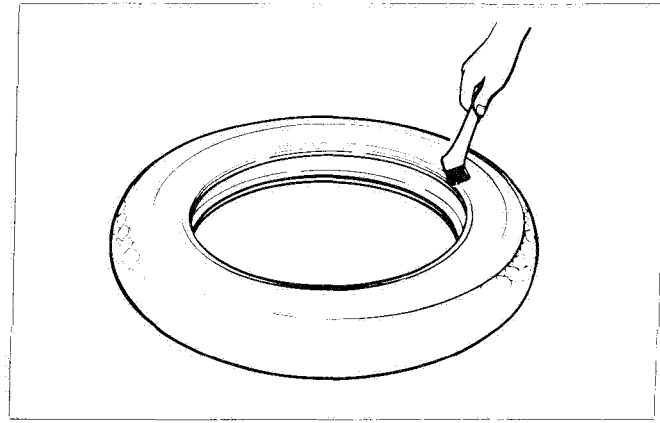

- When installing the tire, make certain that the directional arrow faces the direction of wheel rotation and align the balancing dot of the tire with the valve stem as shown.

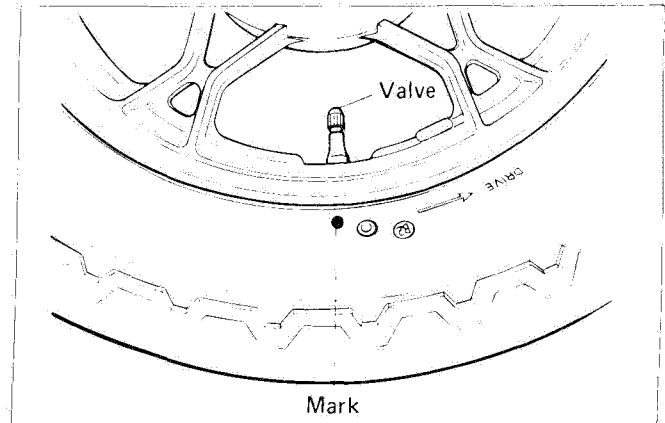

### CAUTION:

There is not directional arrow on the front tire, so mount the tire so that I.D. number faces to the left side when the tire is in the forward running direction.

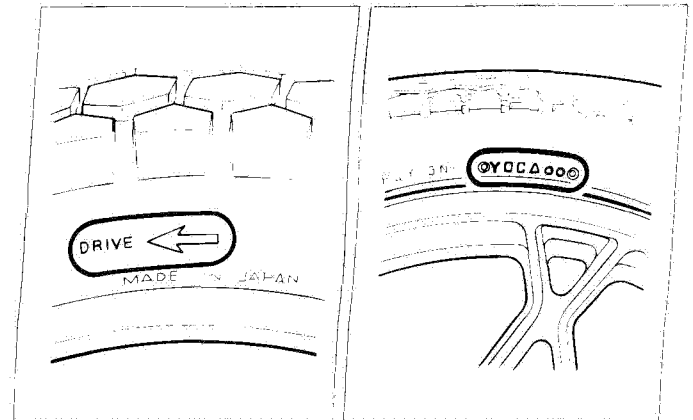

- Set the bead pushing roller ①.
- Rotate operation arm around the rim to mount the bead completely. Do the bottom bead first, then the upper bead.
- Remove the wheel from the tire changer, and install the valve core in the valve stem.

### NOTE:

Before installing the valve core, inspect the core.

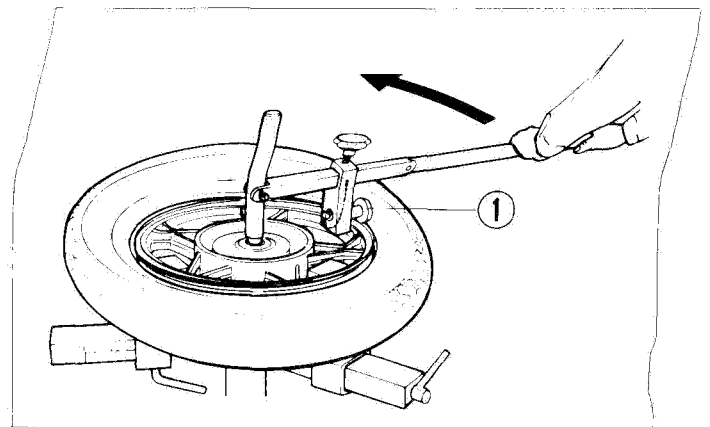

- Bounce the tire several times while rotating. This makes the tire bead expand outwards, and thus makes inflation easier.

**NOTE:**

Before inflating, confirm that the balance mark lines up with the valve stem.

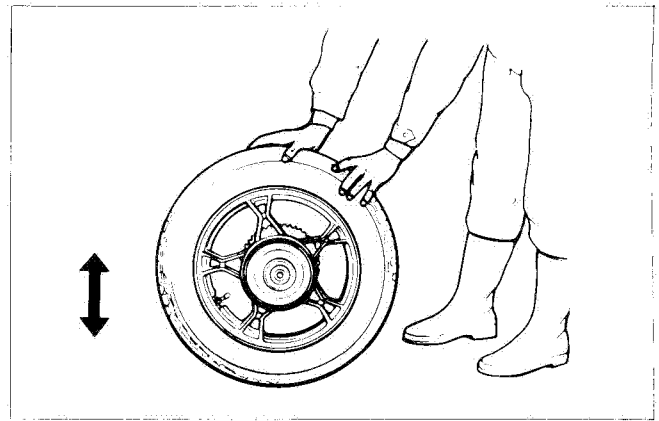

- Pump up the tire with air.

**WARNING:**

Do not inflate the tire to more than 4.0 kg/cm<sup>2</sup> (56 psi). The tire could burst with sufficient force to cause severe injury. Never stand directly over the tire while inflating it.

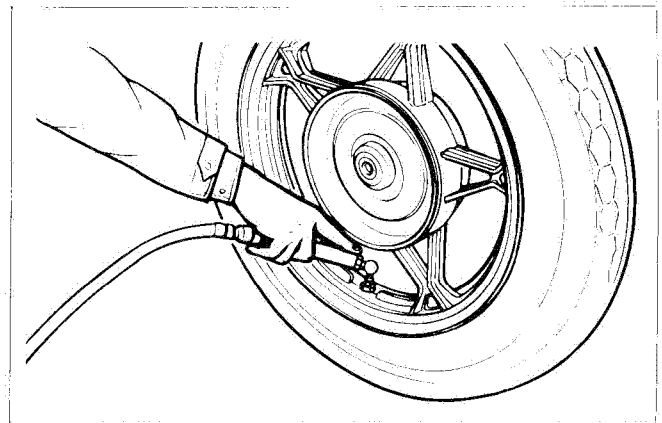
**NOTE:**

Check the "rim line" cast on the tire side walls. It must be equidistant from the wheel rim all the way around. If the distance between the rim line and the wheel rim varies, this indicates that the bead is not properly seated. If this is so, deflate the tire completely, and unseat the bead for the both sides. Coat the bead with lubricant, and try again.

- After tire is properly seated to the wheel rim, adjust the pressure to the recommended pressure. Correct the wheel balance if necessary.

**WARNING:**

Do not run a repaired tire more than 50 km/h (30 mph) within 24 hours after tire repairing, since the patch may not be completely cured. Do not exceed 130 km/h (80 mph) with a repaired tire.

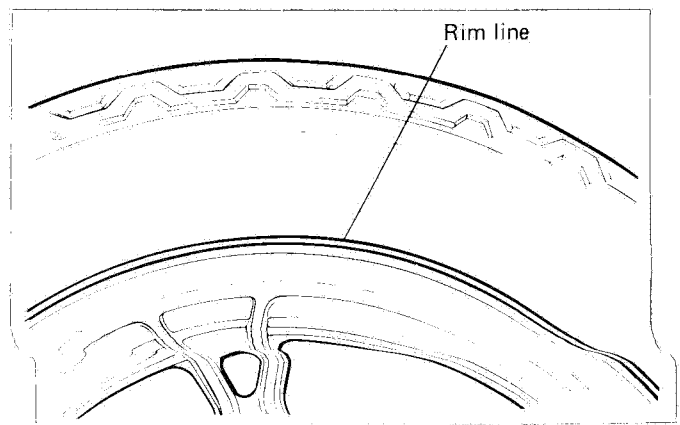

## REAR SWINGARM AND SUSPENSION

## SWINGARM

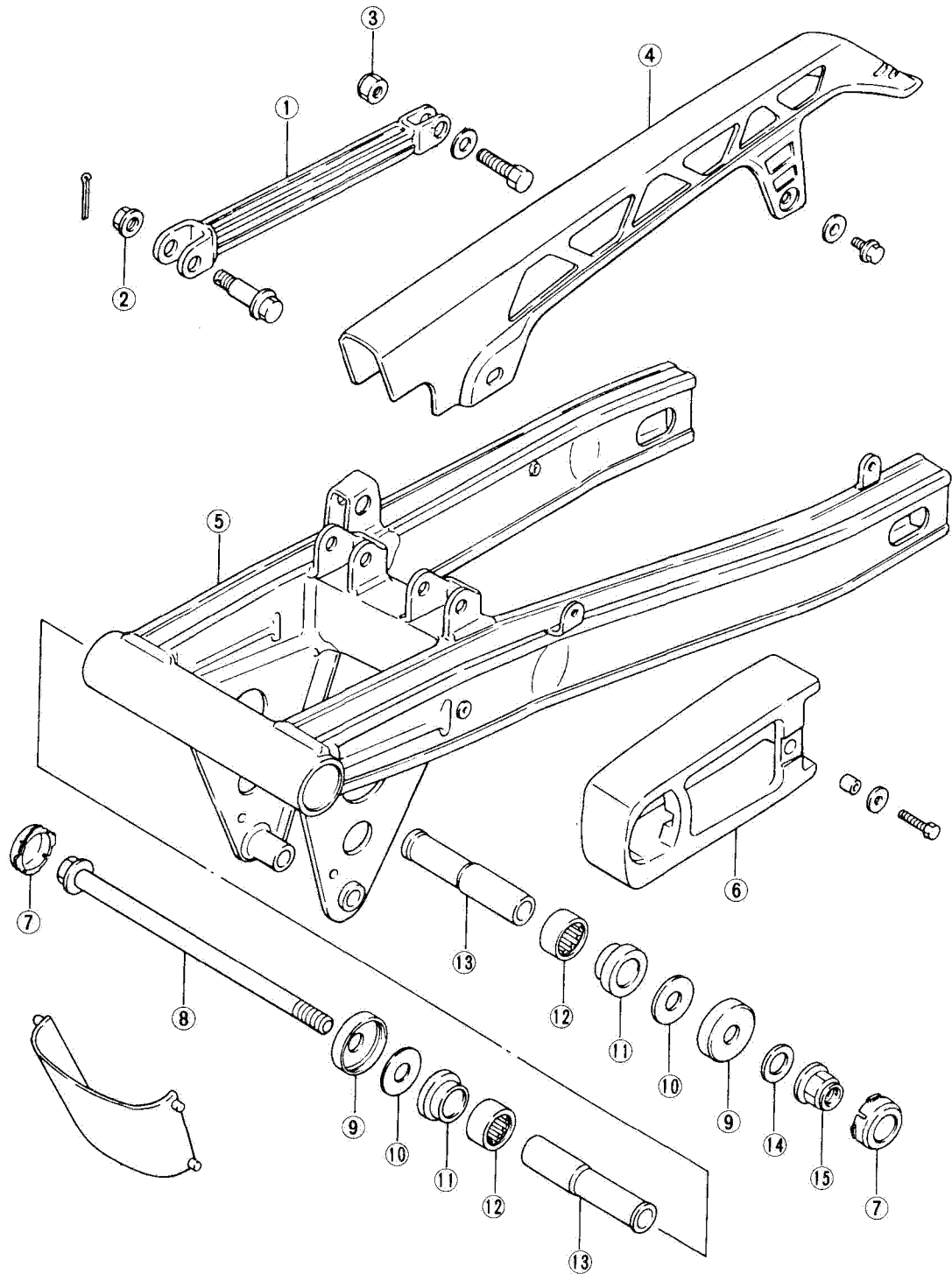

Tightening torque		
Item	N·m	kg-m
②	10 - 15	1.0 - 1.5
③	20 - 30	2.0 - 3.0
⑮	50 - 80	5.0 - 8.0

- ① Torque link
- ② Torque link nut (Front side)
- ③ Torque link nut (Rear side)
- ④ Chain case
- ⑤ Swingarm
- ⑥ Chain buffer
- ⑦ Cap
- ⑧ Pivot shaft
- ⑨ Cover
- ⑩ Washer
- ⑪ Bushing
- ⑫ Bearing
- ⑬ Spacer
- ⑭ Washer
- ⑮ Pivot shaft nut

**REAR SHOCK ABSORBER**

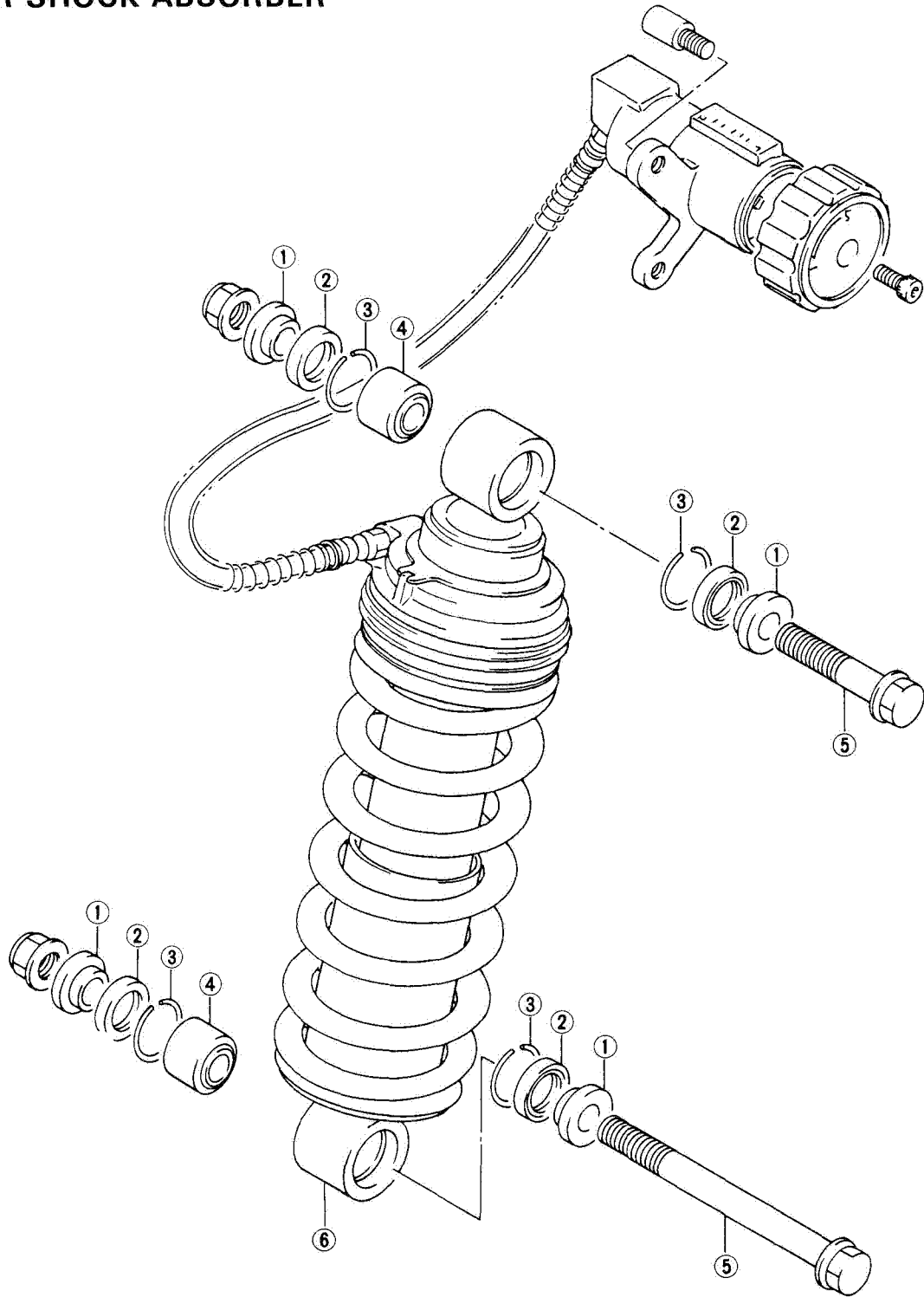

- ① Spacer
- ② Dust seal
- ③ Pin
- ④ Bearing
- ⑤ Shock absorber fitting bolt
- ⑥ Rear shock absorber

Tightening torque		
Item	N·m	kg·m
⑤	40 - 60	4.0 - 6.0

### CUSHION ROD, LEVER AND BRACKET

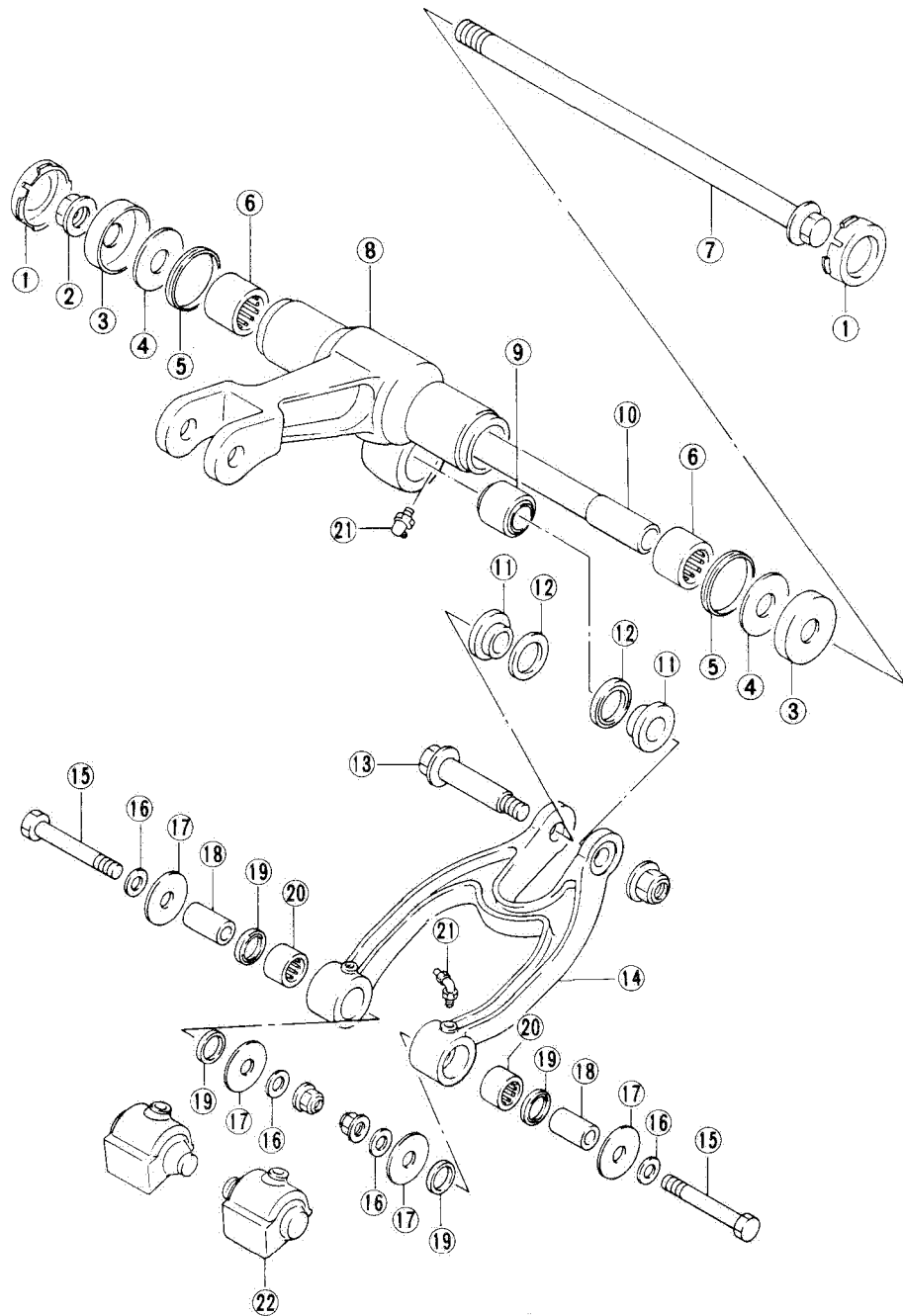

- ① Cap
- ② Cushion lever center shaft nut
- ③ Dust cover
- ④ Washer
- ⑤ Dust seal
- ⑥ Bearing
- ⑦ Cushion lever center shaft
- ⑧ Cushion lever
- ⑨ Bearing
- ⑩ Spacer
- ⑪ Spacer
- ⑫ Dust seal
- ⑬ Cushion lever front shaft
- ⑭ Cushion lever rod
- ⑮ Cushion rod lower bolt
- ⑯ Washer
- ⑰ Washer
- ⑱ Spacer
- ⑲ Dust seal
- ⑳ Bearing
- ㉑ Nipple
- ㉒ Boot

Tightening torque		
Item	N·m	kg·m
②	40 - 60	4.0 - 6.0
⑬	40 - 60	4.0 - 6.0
⑮	18 - 28	1.8 - 2.8

## REMOVAL AND DISASSEMBLY

- Remove the following items to remove the rear swingarm and related parts.
  - \* Seat.
  - \* Both frame covers
  - \* Brake hose union bolt (Master cylinder side)

- Remove the rear wheel. (See page 7-34)
- Remove the spring adjuster mounting bolt ①.



- Remove the swingarm pivot shaft nut ① and cushion lever bolt ②.

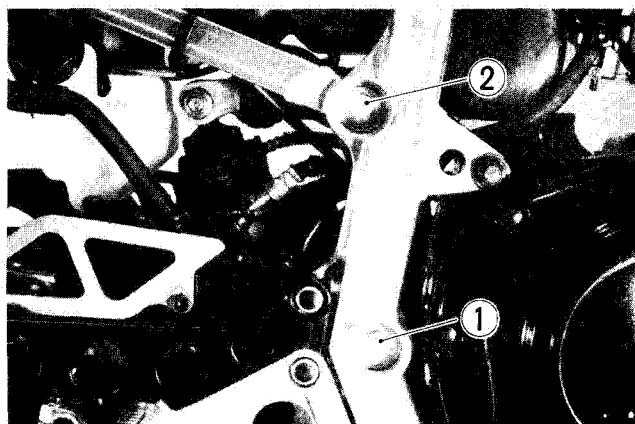

- Take off the rear suspension assembly.

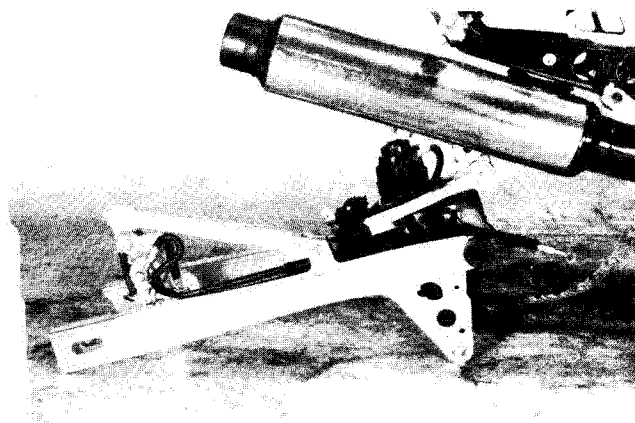

- Pull out the cotter pin and remove the torque link.

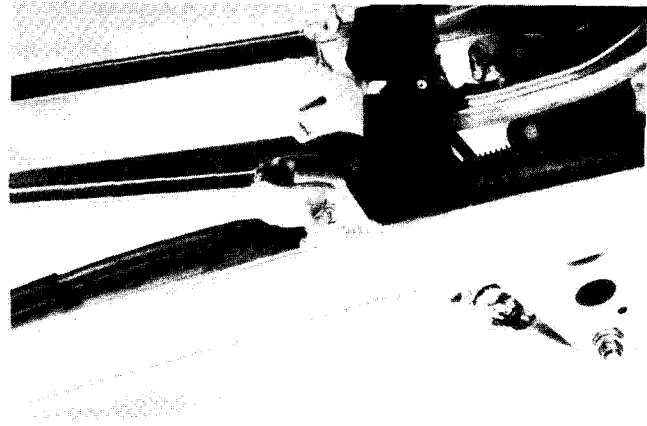

- Remove the rear shock absorber.

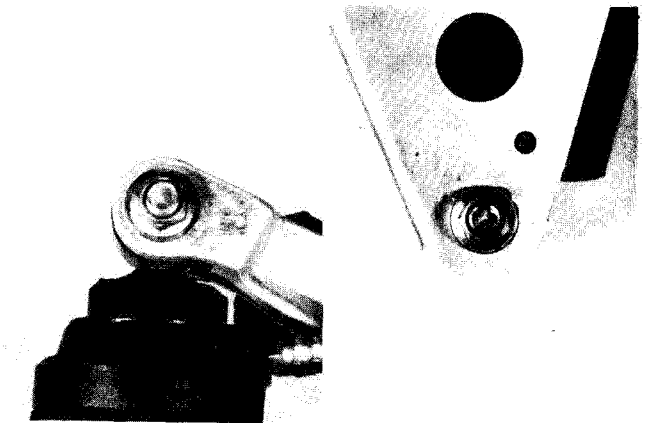

- Remove the cushion lever and cushion rod

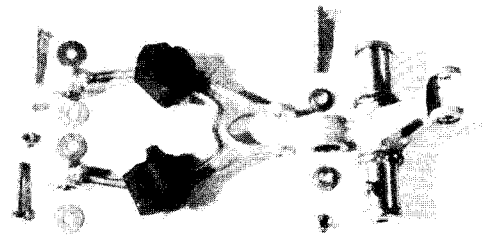
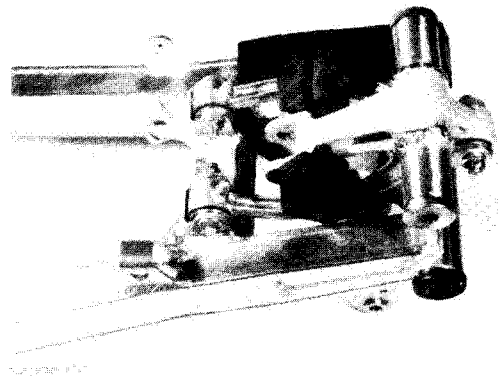



**SWINGARM**

- Remove the dust seal, washer and two spacer.
- Remove the bushing.

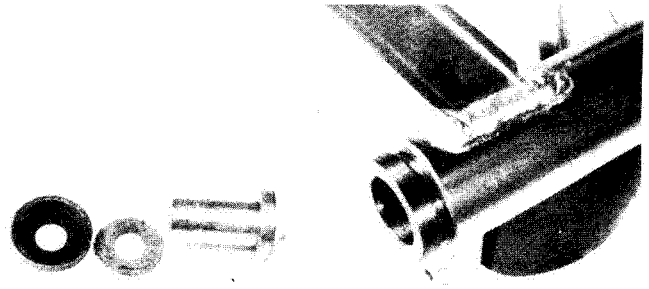

- Remove the bearing by using the special tools.

09923-74510	Bearing puller
09930-30102	Sliding shaft

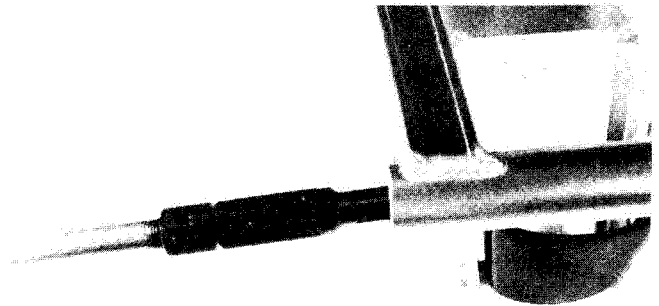

**CUSHION LEVER**

- Remove the dust seal, washer, O-ring and spacer.

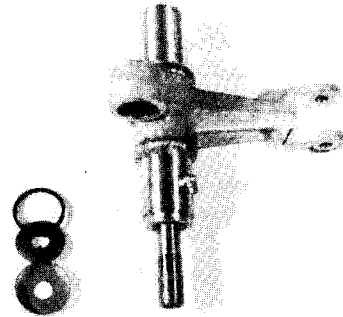

- Remove the bearing by using the special tools.

09923-74510	Bearing puller
09930-30102	Sliding shaft

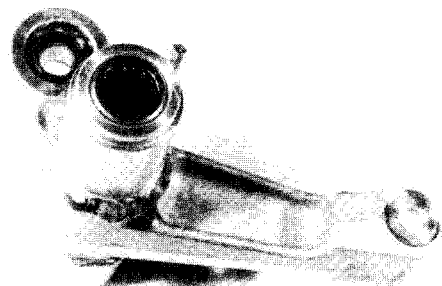

**INSPECTION****SWING ARM PIVOT SHAFT**

Using a dial gauge, check the pivot shaft for runout and replace it if the runout exceeds the limit.

09900-20606	Dial gauge (1/100)
Service Limit	0.3 mm

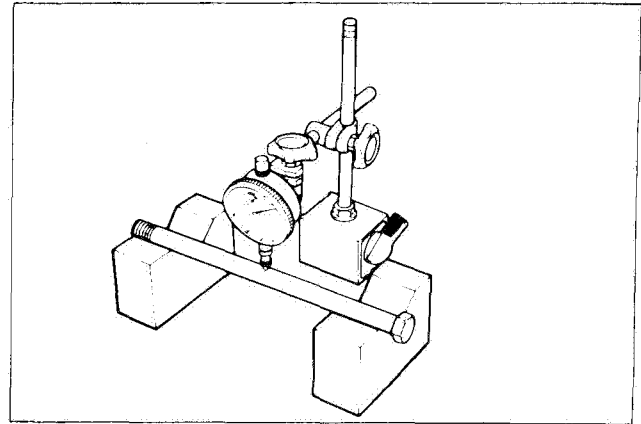
**BEARINGS (NEEDLE ROLLER BEARING AND SPHERICAL BALL BEARINGS).**

- Insert the spacer in the bearing and check the play by moving the spacer up and down. If an excessive play is noted, replace the bearing with a new one.
- Spherical ball bearings are located on upper and lower shock absorber. Insert the mounting bolt to the bearing and check the play by moving the bolt. If an excessive play is noted, replace the bearing with a new one.

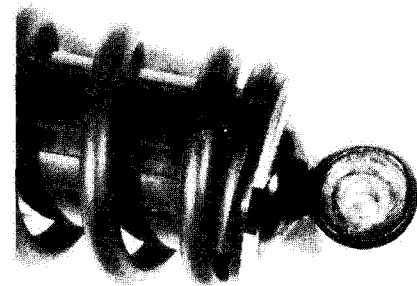
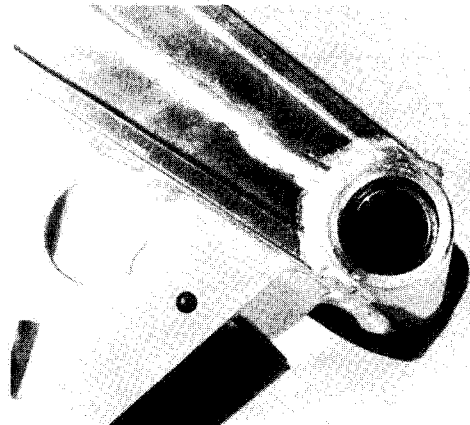

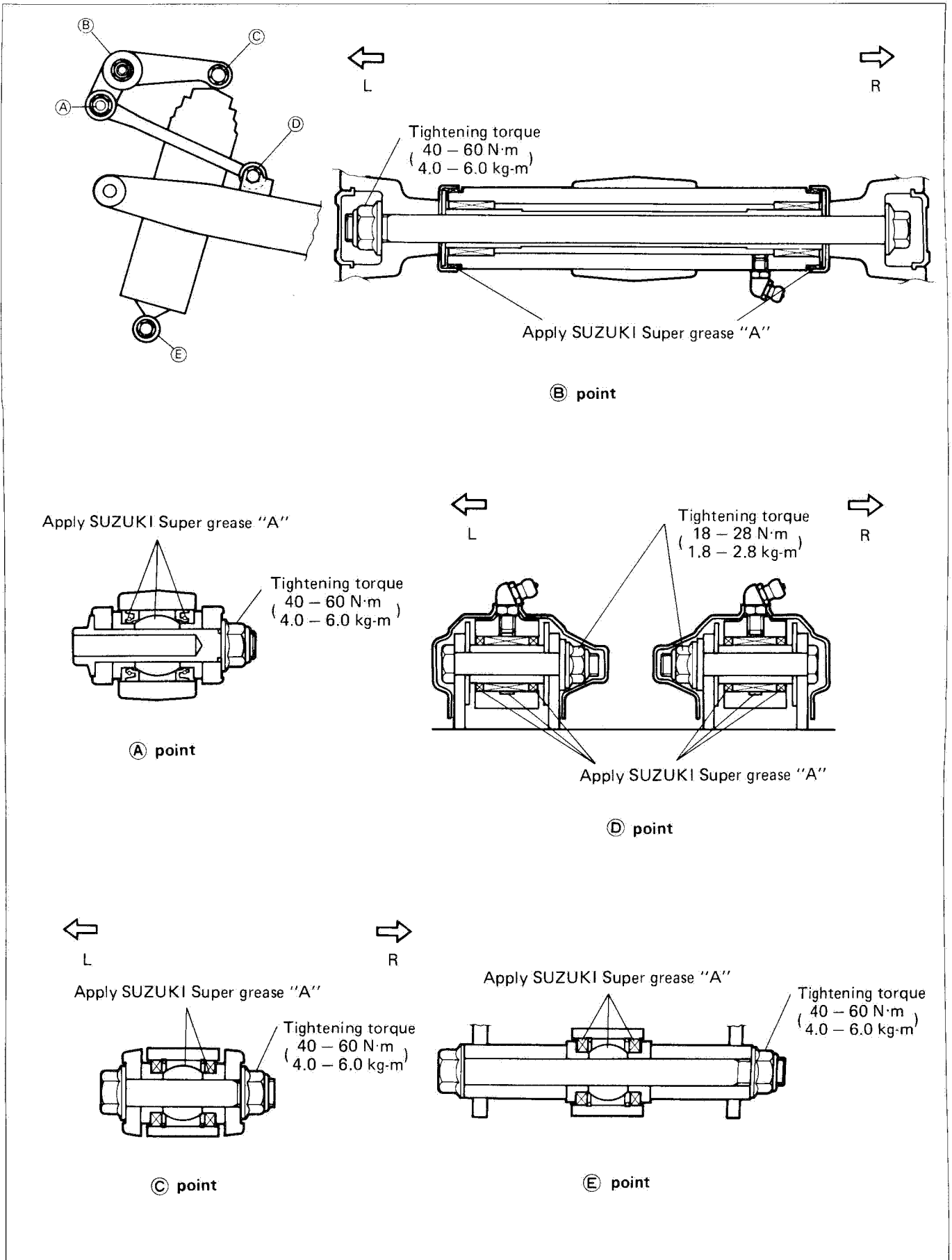

## REAR SHOCK ABSORBER

- Inspect the rear shock absorber for any oil leakage by turning the adjuster knob clockwise or counter-clockwise. When turning the adjuster knob, check the rear shock absorber for smooth operation.

### CAUTION:

Do not attempt to disassemble the rear shock absorber unit. It is not serviceable.

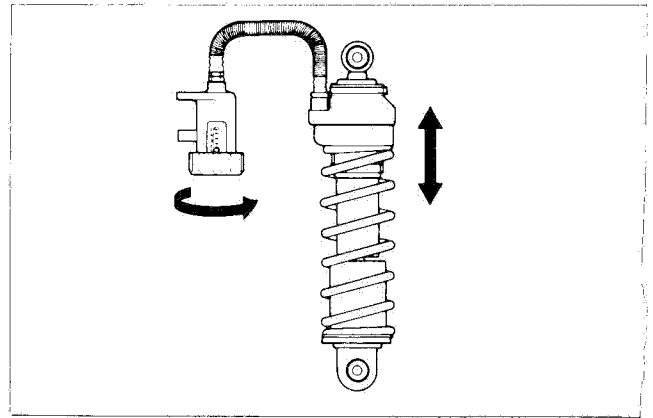

## REASSEMBLY

Reassemble and remount the swingarm in the reverse order of disassembly and removal, and also carry out the following steps:

### SWINGARM BEARINGS

Force-fit the bearings into the swingarm by using the special tool.

09924-84510	Bearing installer set
-------------	-----------------------

### NOTE:

When installing two bearings, punch-marked side of bearing comes outside.

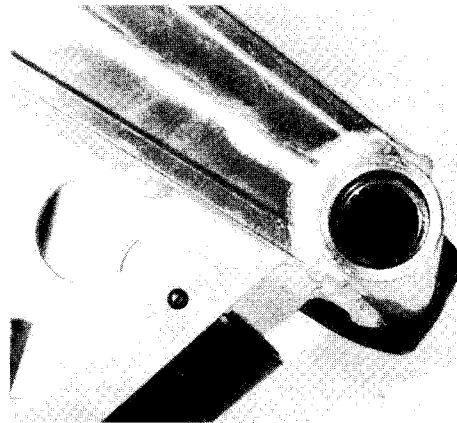

### SPACER AND DUST SEAL COVER

Apply grease to the spacer and dust seal cover when installing them.

99000-25010	SUZUKI Super grease "A"
-------------	-------------------------

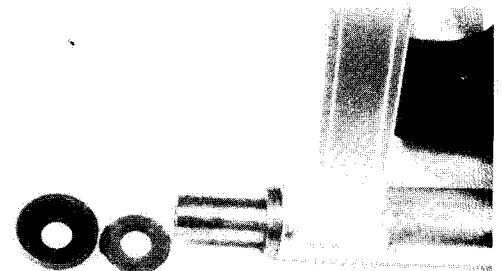

### CUSHION ROD BEARINGS AND LEVER BEARINGS

Install the right and left bearings by using the special tool.

09941-34513	Bearing installer set
-------------	-----------------------

### NOTE:

When installing the two bearings, punch-marked side of bearing faces outwards.

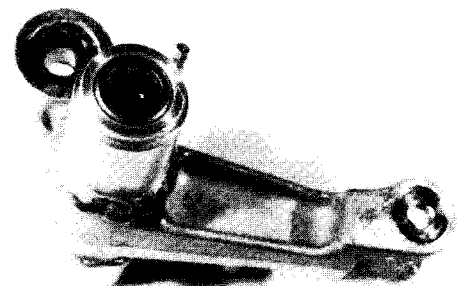

- Apply grease to the spacer and bearings.

99000-25010	SUZUKI Super grease "A"
-------------	-------------------------

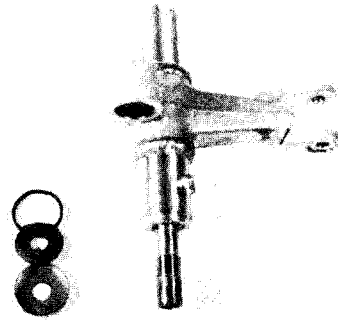

## REAR SUSPENSION

The rear suspension spring pre-load is adjustable to compensate for rider, passenger, load, road conditions and motorcycle speed. The adjustment can be performed by changing the hydraulic spring adjuster position. To change the spring pre-load setting, place the motorcycle on the center stand and turn the hydraulic spring adjuster to the desired position. Position "1" provides the softest spring tension and position "5" provides the stiffest spring tension. This motorcycle is delivered from the factory with its adjuster position set on the "3" position.

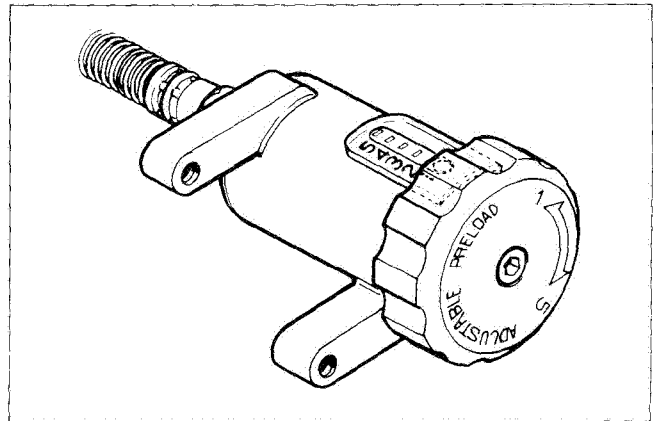

## FINAL INSPECTION AND ADJUSTMENT

After installing rear swingarm, shock absorber, brake and rear wheel, following adjustments are required before driving motorcycle.

- \* Drive chain ..... 2-13
- \* Rear brake ..... 2-14
- \* Tire pressure ..... 2-18
- \* Chassis bolts and nuts ..... 2-19
- \* Shock absorber

# SERVICING INFORMATION

## CONTENTS

<i>TROUBLESHOOTING</i> .....	8- 1
<i>WIRING DIAGRAM</i> .....	8- 9
<i>WIRE, CABLE AND HOSE ROUTING</i> .....	8-10
<i>SPECIAL TOOLS</i> .....	8-15
<i>TIGHTENING TORQUE</i> .....	8-20
<i>SERVICE DATA</i> .....	8-24

## TROUBLESHOOTING

## ENGINE

Complaint	Symptom and possible causes	Remedy
<p><b>Engine will not start, or is hard to start.</b></p>	<p><b>Compression too low</b></p> <ol style="list-style-type: none"> <li>1. Valve clearance out of adjustment.</li> <li>2. Worn valve guides or poor seating of valves.</li> <li>3. Valves mistiming.</li> <li>4. Piston rings excessively worn.</li> <li>5. Worn-down cylinder bores.</li> <li>6. Starter motor cranks but too slowly.</li> </ol> <p><b>Plugs not sparking</b></p> <ol style="list-style-type: none"> <li>1. Fouled spark plugs.</li> <li>2. Wet spark plug.</li> <li>3. Defective ignition coil.</li> <li>4. Open or short in high-tension cords.</li> <li>5. Defective signal generator or transistor unit.</li> </ol> <p><b>No fuel reaching the carburetors</b></p> <ol style="list-style-type: none"> <li>1. Clogged hole in the fuel tank cap.</li> <li>2. Clogged or defective fuel cock.</li> <li>3. Defective carburetor float valve.</li> <li>4. Clogged fuel pipe or suction cock pipe.</li> <li>5. Defective fuel cock diaphragm.</li> </ol>	<p>Adjust. Repair, or replace. Adjust. Replace. Replace, or rebore. Consult "electrical complaints".</p> <p>Clean. Clean and dry. Replace. Replace. Replace.</p> <p>Clean. Clean or replace. Replace. Clean. Replace.</p>
<p><b>Engine stalls easily.</b></p>	<ol style="list-style-type: none"> <li>1. Fouled spark plugs.</li> <li>2. Defective signal generator or transistor unit.</li> <li>3. Clogged fuel pipe.</li> <li>4. Clogged jets in carburetors.</li> <li>5. Valve clearance out of adjustment.</li> </ol>	<p>Clean. Replace Replace. Clean. Clean.</p>
<p><b>Noisy engine.</b></p>	<p><b>Excessive valve chatter</b></p> <ol style="list-style-type: none"> <li>1. Valve clearance too large.</li> <li>2. Weakened or broken valve springs.</li> <li>3. Camshaft journal worn and burnt.</li> </ol> <p><b>Noise appears to come from pistons</b></p> <ol style="list-style-type: none"> <li>1. Pistons or cylinders worn down.</li> <li>2. Combustion chambers fouled with carbon.</li> <li>3. Piston pins or piston pin bore worn.</li> <li>4. Piston rings or ring groove worn.</li> </ol> <p><b>Noise seems to come from timing chain</b></p> <ol style="list-style-type: none"> <li>1. Stretched chain.</li> <li>2. Worn sprockets.</li> <li>3. Tension adjuster not working.</li> </ol> <p><b>Noise seems to come from clutch</b></p> <ol style="list-style-type: none"> <li>1. Worn splines of countershaft or hub.</li> <li>2. Worn teeth of clutch plates.</li> <li>3. Distorted clutch plates, driven and drive.</li> </ol> <p><b>Noise seems to come from crankshaft</b></p> <ol style="list-style-type: none"> <li>1. Rattling bearings due to wear.</li> <li>2. Big-end bearings worn and burnt.</li> <li>3. Journal bearing worn and burnt.</li> </ol>	<p>Adjust. Replace. Replace.</p> <p>Replace. Clean. Replace. Replace.</p> <p>Replace. Replace. Replace.</p> <p>Replace. Replace. Replace.</p> <p>Replace. Replace. Replace.</p>

Complaint	Symptom and possible causes	Remedy
<b>Noisy engine.</b>	<b>Noise seems to come from transmission</b> 1. Gears worn or rubbing. 2. Badly worn splines. 3. Primary gears worn or rubbing.	Replace. Replace. Replace.
<b>Slipping clutch</b>	1. Clutch control out of adjustment or loss of play. 2. Weakened clutch springs. 3. Worn or distorted pressure plate. 4. Distorted clutch plates, driven and drive.	Adjust. Replace. Replace. Replace.
<b>Dragging clutch</b>	1. Clutch control out of adjustment or too much play. 2. Some clutch springs weakened while others are not. 3. Distorted pressure plate or clutch plates.	Adjust. Replace. Replace.
<b>Transmission will not shift</b>	1. Broken gearshift cam. 2. Distorted gearshift forks.	Replace. Replace.
<b>Transmission will not shift back.</b>	1. Broken return spring on shift shaft. 2. Shift shafts are rubbing or sticky.	Replace. Repair or replace.
<b>Transmission jumps out of gear.</b>	1. Worn shifting gears on drive shaft or countershaft. 2. Distorted or worn gearshift forks. 3. Weakened stopper spring on gearshift stopper.	Replace. Replace. Replace.
<b>Engine idles poorly.</b>	1. Valve clearance out of adjustment. 2. Poor seating of valves. 3. Defective valve guides. 4. Spark plug gaps too wide. 5. Defective ignition coil. 6. Defective signal generator or transistor unit. 7. Float-chamber fuel level out of adjustment in carburetors. 8. Clogged jets or imbalance of carburetors.	Adjust. Repair or replace. Replace. Adjust. Replace. Replace. Replace. Clean or adjust.
<b>Engine runs poorly in high-speed range.</b>	1. Valve springs weakened. 2. Valve timing out of adjustment. 3. Spark plug gaps too narrow. 4. Clogged jets or imbalance of carburetors. 5. Defective ignition coil. 6. Defective signal generator or transistor unit. 7. Float-chamber fuel level too low. 8. Clogged air cleaner element. 9. Clogged fuel pipe, resulting in inadequate fuel supply to carburetors. 10. Clogged suction cock pipe.	Replace. Adjust. Adjust. Clean or adjust. Replace. Replace. Adjust. Clean. Clean, and prime. Clean.
<b>Dirty or heavy exhaust smoke</b>	1. Too much engine oil in the engine. 2. Worn piston rings or cylinders. 3. Worn valve guides. 4. Cylinder walls scored or scuffed. 5. Worn valves stems. 6. Defective stem seal.	Check with level inspection window, drain out excess oil. Replace. Replace. Rebore or replace. Replace. Replace.



Complaint	Symptom and possible causes	Remedy
Engine lacks power	<ol style="list-style-type: none"> <li>1. Loss of valve clearance.</li> <li>2. Weakened valve springs.</li> <li>3. Valve timing out of adjustment.</li> <li>4. Worn piston rings or cylinders.</li> <li>5. Poor seating of valves.</li> <li>6. Spark plug gaps incorrect.</li> <li>7. Clogged jets in carburetors.</li> <li>8. Float-chamber fuel level out of adjustment.</li> <li>9. Clogged air cleaner element.</li> <li>10. Carburetor balancing screw loose.</li> <li>11. Sucking air from intake pipe.</li> <li>12. Too much engine oil in the engine.</li> </ol>	<p>Adjust. Replace. Adjust. Replace. Repair. Adjust or replace. Clean. Adjust. Clean. Retighten. Retighten or replace. Drain out excess oil.</p>
Engine overheats.	<ol style="list-style-type: none"> <li>1. Heavy carbon deposit on piston crowns.</li> <li>2. Not enough oil in the engine.</li> <li>3. Defective oil pump or clogged oil circuit.</li> <li>4. Fuel level too low in float chambers.</li> <li>5. Suck air from intake pipes.</li> <li>6. Use incorrect engine oil.</li> <li>7. Defective cooling system.</li> </ol>	<p>Clean. Add oil. Replace or clean. Adjust. Retighten or replace. Change. See radiator section.</p>

## CARBURETOR

Complaint	Symptom and possible causes	Remedy
Trouble with starting	<ol style="list-style-type: none"> <li>1. Starter jet is clogged.</li> <li>2. Starter pipe is clogged.</li> <li>3. Air leaking from a joint between starter body and carburetor.</li> <li>4. Air leaking from carburetor's joint or vacuum gauge joint.</li> <li>5. Starter plunger is not operating properly.</li> </ol>	<p>Clean. Clean. Check starter body and carburetor for tightness, adjust and replace gasket. Check and adjust. Check and adjust.</p>
Idling or low-speed trouble	<ol style="list-style-type: none"> <li>1. Pilot jet, pilot air jet are clogged or loose.</li> <li>2. Air leaking from carburetor's joint, vacuum gauge joint, or starter.</li> <li>3. Pilot outlet or bypass is clogged.</li> <li>4. Starter plunger is not fully closed.</li> </ol>	<p>Check and clean. Check and adjust. Check and clean. Check and adjust.</p>
Medium- or high-speed trouble	<ol style="list-style-type: none"> <li>1. Main jet or main air jet is clogged.</li> <li>2. Needle jet is clogged.</li> <li>3. Throttle valve is not operating properly.</li> <li>4. Filter is clogged.</li> </ol>	<p>Check and clean. Check and clean. Check throttle valve for operation. Check and clean.</p>
Overflow and fuel level fluctuations	<ol style="list-style-type: none"> <li>1. Needle valve is worn or damaged.</li> <li>2. Spring in needle valve is broken.</li> <li>3. Float is not working properly.</li> <li>4. Foreign matter has adhered to needle valve.</li> <li>5. Fuel level is too high or low.</li> <li>6. Clogged carburetor air vent pipe.</li> </ol>	<p>Replace. Replace. Check and adjust. Clean. Adjust float height. Clean.</p>

**RADIATOR**

Symptom	Probable cause	Remedy
Engine overheats.	<ol style="list-style-type: none"> <li>1. Not enough cooling water.</li> <li>2. Radiator core is clogged with dirt or trashes.</li> <li>3. Erratic thermostat, stuck in closed position.</li> <li>4. Faulty cooling fan.</li> <li>5. Defective thermo switch.</li> <li>6. Clogged water passage.</li> <li>7. Air trapped in the cooling circuit.</li> <li>8. Defective water pump.</li> <li>9. Use incorrect cooling water.</li> </ol>	Add. Clean. Replace. Repair or replace. Replace. Clean. Bleed out air. Replace. Replace.
Engine overcools.	<ol style="list-style-type: none"> <li>1. Erratic thermostat, stuck in full-open position.</li> <li>2. Defective thermo switch.</li> <li>3. Extremely cold weather.</li> </ol>	Replace. Replace. Put on the radiator cover.

**ELECTRICAL**

Complaint	Symptom and possible causes	Remedy
No sparking or poor sparking	<ol style="list-style-type: none"> <li>1. Defective ignition coil.</li> <li>2. Defective spark plugs.</li> <li>3. Defective signal generator or transistor unit.</li> </ol>	Replace. Replace. Replace.
Spark plugs soon become fouled with carbon.	<ol style="list-style-type: none"> <li>1. Mixture too rich.</li> <li>2. Idling speed set too high.</li> <li>3. Incorrect gasoline.</li> <li>4. Dirty element in air cleaner.</li> <li>5. Spark plugs too cold.</li> </ol>	Adjust carburetors. Adjust carburetors. Change. Clean. Replace by hot type plugs.
Spark plugs become fouled too soon.	<ol style="list-style-type: none"> <li>1. Worn piston rings.</li> <li>2. Pistons or cylinders worn.</li> <li>3. Excessive clearance of valve stems in valve guides.</li> <li>4. Worn stem oil seal.</li> </ol>	Replace. Replace. Replace. Replace.
Spark plug electrodes overheat or burn.	<ol style="list-style-type: none"> <li>1. Spark plugs too hot.</li> <li>2. The engine overheats.</li> <li>3. Spark plugs loose.</li> <li>4. Mixture too lean.</li> </ol>	Replace by cold type plugs. Tune up. Retighten. Adjust carburetors.
Generator does not charge.	<ol style="list-style-type: none"> <li>1. Open or short in lead wires, or loose lead connections.</li> <li>2. Shorted, grounded or open generator coils.</li> <li>3. Shorted or punctured regulator/rectifier.</li> </ol>	Repair or replace or retighten. Replace. Replace.
Generator does charge, but charging rate is below the specification.	<ol style="list-style-type: none"> <li>1. Lead wires tend to get shorted or open-circuited or loosely connected at terminals.</li> <li>2. Grounded or open-circuited stator coils of generator.</li> <li>3. Defective regulator/rectifier.</li> <li>4. Not enough electrolyte in the battery.</li> <li>5. Defective cell plates in the battery.</li> </ol>	Repair, or retighten. Replace. Replace. Add distilled water to the MAX. level. Replace the battery.

Complaint	Symptom and possible causes	Remedy
<b>Generator overcharges.</b>	<ol style="list-style-type: none"><li>1. Internal short-circuit in the battery.</li><li>2. Resistor element in the regulator/rectifier damaged or defective.</li><li>3. Regulator/rectifier poorly grounded.</li></ol>	Replace the battery. Replace.  Clean and tighten ground connection.
<b>Unstable charging</b>	<ol style="list-style-type: none"><li>1. Lead wire insulation frayed due to vibration, resulting in intermittent shorting.</li><li>2. Generator internally shorted.</li><li>3. Defective regulator/rectifier.</li></ol>	Repair or replace.  Replace. Replace.
<b>Starter button is not effective.</b>	<ol style="list-style-type: none"><li>1. Battery run down.</li><li>2. Defective switch contacts.</li><li>3. Brushes not seating properly on commutator in starter motor.</li><li>4. Defective starter relay.</li></ol>	Recharge or replace. Replace. Repair or replace.  Replace.

## BATTERY

Symptom	Probable causes	Remedy
"Sulfation", acidic white powdery substance or spots on surfaces of cell plates.	<ol style="list-style-type: none"> <li>1. Not enough electrolyte</li> <li>2. Battery case is cracked.</li> <li>3. Battery has been left in a run-down condition for a long time.</li> <li>4. Adulterated electrolyte (Foreign matter has entered the battery and become mixed with the electrolyte.</li> </ol>	<p>Add distilled water, if the battery has not been damaged and "sulfation" has not advanced too far, and recharge. Replace the battery. Replace the battery.</p> <p>If "sulfation" has not advanced too far, try to restore the battery by replacing the electrolyte, recharging it fully with the battery detached from the motor-cycle and then adjusting electrolyte S.G.</p>
Battery runs down quickly.	<ol style="list-style-type: none"> <li>1. The charging method is not correct.</li> <li>2. Cell plates have lost much of their active material as a result of over-charging.</li> <li>3. A short-circuit condition exists within the battery due to excessive accumulation of sediments caused by the high electrolyte S.G.</li> <li>4. Electrolyte S.G. is too low.</li> <li>5. Adulterated electrolyte.</li> <li>6. Battery is too old.</li> </ol>	<p>Check the generator, regulator/rectifier and circuit connections, and make necessary adjustments to obtain specified charging operation. Replace the battery, and correct the charging system. Replace the battery</p> <p>Recharge the battery fully and adjust electrolyte S.G. Replace the electrolyte, recharge the battery and then adjust S.G. Replace the battery.</p>
Reversed battery polarity.	The battery has been connected the wrong way round in the system, so that it is being charged in the reverse direction.	Replace the battery and be sure to connect the battery properly.
Battery "sulfation"	<ol style="list-style-type: none"> <li>1. Charging rate too low or too high. (When not in use batteries should be recharged at least once a month to avoid sulfation.)</li> <li>2. Battery electrolyte excessive or insufficient, or its specific gravity too high or too low.</li> <li>3. The battery left unused for too long in cold climate.</li> </ol>	<p>Replace the battery.</p> <p>Keep the electrolyte up to the prescribed level, or adjust the S.G. by consulting the battery maker's directions. Replace the battery, if badly sulfated.</p>
Battery discharges too rapidly.	<ol style="list-style-type: none"> <li>1. Dirty container top and sides.</li> <li>2. Impurities in the electrolyte or electrolyte S.G. is too high.</li> </ol>	<p>Clean.</p> <p>Change the electrolyte by consulting the battery maker's directions.</p>

## CHASSIS

Complaint	Symptom and possible causes	Remedy
<b>Heavy steering</b>	<ol style="list-style-type: none"> <li>1. Steering stem nut overtightened.</li> <li>2. Broken bearing in steering stem.</li> <li>3. Distorted steering stem.</li> <li>4. Not enough pressure in tires.</li> </ol>	Adjust. Replace. Replace. Adjust.
<b>Wobbly handle</b>	<ol style="list-style-type: none"> <li>1. Loss of balance between right and left suspension</li> <li>2. Distorted front fork.</li> <li>3. Distorted front axle or crooked tire.</li> </ol>	Replace. Repair or replace. Replace.
<b>Wobbly front wheel</b>	<ol style="list-style-type: none"> <li>1. Distorted wheel.</li> <li>2. Worn-down front wheel bearings.</li> <li>3. Defective or incorrect tire.</li> <li>4. Loose nut on axle.</li> <li>5. Loose nuts on the rear shock.</li> <li>6. Worn swing arm related bearings.</li> </ol>	Replace. Replace. Replace. Retighten. Retighten. Replace.
<b>Front suspension too soft.</b>	<ol style="list-style-type: none"> <li>1. Weakened springs.</li> <li>2. Not enough fork oil.</li> </ol>	Replace. Refill
<b>Front suspension too stiff</b>	<ol style="list-style-type: none"> <li>1. Fork oil too viscous.</li> <li>2. Too much fork oil.</li> </ol>	Replace. Drain excess oil.
<b>Noisy front suspension</b>	<ol style="list-style-type: none"> <li>1. Not enough fork oil.</li> <li>2. Loose nuts on suspension.</li> </ol>	Refill. Retighten.
<b>Woobly rear wheel</b>	<ol style="list-style-type: none"> <li>1. Distorted wheel rim.</li> <li>2. Worn-down rear wheel or swing arm bearings.</li> <li>3. Defective or incorrect tire.</li> <li>4. Worn swing arm related bearing/bushing.</li> <li>5. Loose nuts on rear suspension.</li> </ol>	Replace. Replace. Replace. Replace. Retighten.
<b>Rear suspension too soft</b>	<ol style="list-style-type: none"> <li>1. Weakened springs.</li> <li>2. Rear suspension adjusters improperly set.</li> <li>3. Oil leakage of rear shock.</li> </ol>	Replace. Adjust. Replace.
<b>Rear suspension too stiff.</b>	<ol style="list-style-type: none"> <li>1. Rear suspension adjusters improperly set.</li> <li>2. Worn swing arm related bearing/bushing.</li> </ol>	Adjust. Replace.
<b>Noisy rear suspension</b>	<ol style="list-style-type: none"> <li>1. Loose nuts on suspension.</li> <li>2. Worn swing arm related bearing/bushing.</li> </ol>	Retighten. Replace.
<b>Poor braking (FRONT and REAR)</b>	<ol style="list-style-type: none"> <li>1. Not enough brake fluid in the reservoir.</li> <li>2. Air trapped in brake fluid circuit.</li> <li>3. Pads or linings worn down.</li> <li>4. Too much play on brake pedal.</li> </ol>	Refill to level mark. Bleed air out. Replace. Adjust.

## BRAKES

Complaint	Symptom and possible causes	Remedy
<b>Insufficient brake power</b>	<ol style="list-style-type: none"> <li>1. Leakage of brake fluid from hydraulic system.</li> <li>2. Worn pads.</li> <li>3. Oil adhesion on engaging surface of pads.</li> <li>4. Worn disc.</li> <li>5. Air in hydraulic system.</li> <li>6. Too much brake pedal play.</li> </ol>	<p>Repair or replace.            Replace.            Clean disc and pads.            Replace.            Bleed air.            Adjust.</p>
<b>Brake squeaking</b>	<ol style="list-style-type: none"> <li>1. Carbon adhesion on pad surface.</li> <li>2. Tilted pad.</li> <li>3. Damaged wheel bearing.</li> <li>4. Loose front-wheel axle or rear-wheel axle.</li> <li>5. Worn pads.</li> <li>6. Foreign material in brake fluid.</li> <li>7. Clogged return port of master cylinder.</li> </ol>	<p>Repair surface with sand-paper.            Modify pad fitting.            Replace.            Tighten to specified torque.            Replace.            Replace brake fluid.            Disassemble and clean master cylinder.</p>
<b>Excessive brake lever stroke</b>	<ol style="list-style-type: none"> <li>1. Air in hydraulic system.</li> <li>2. Insufficient brake fluid.</li> <li>3. Improper quality of brake fluid.</li> </ol>	<p>Bleed air.            Replenish fluid to specified level; bleed air.            Replace with correct fluid.</p>
<b>Leakage of brake fluid</b>	<ol style="list-style-type: none"> <li>1. Insufficient tightening of connection joints.</li> <li>2. Cracked hose.</li> <li>3. Worn piston and/or cup.</li> </ol>	<p>Tighten to specified torque.            Replace.            Replace piston and/or cup.</p>



# WIRE, CABLE AND HOSE ROUTING

## WIRE ROUTING

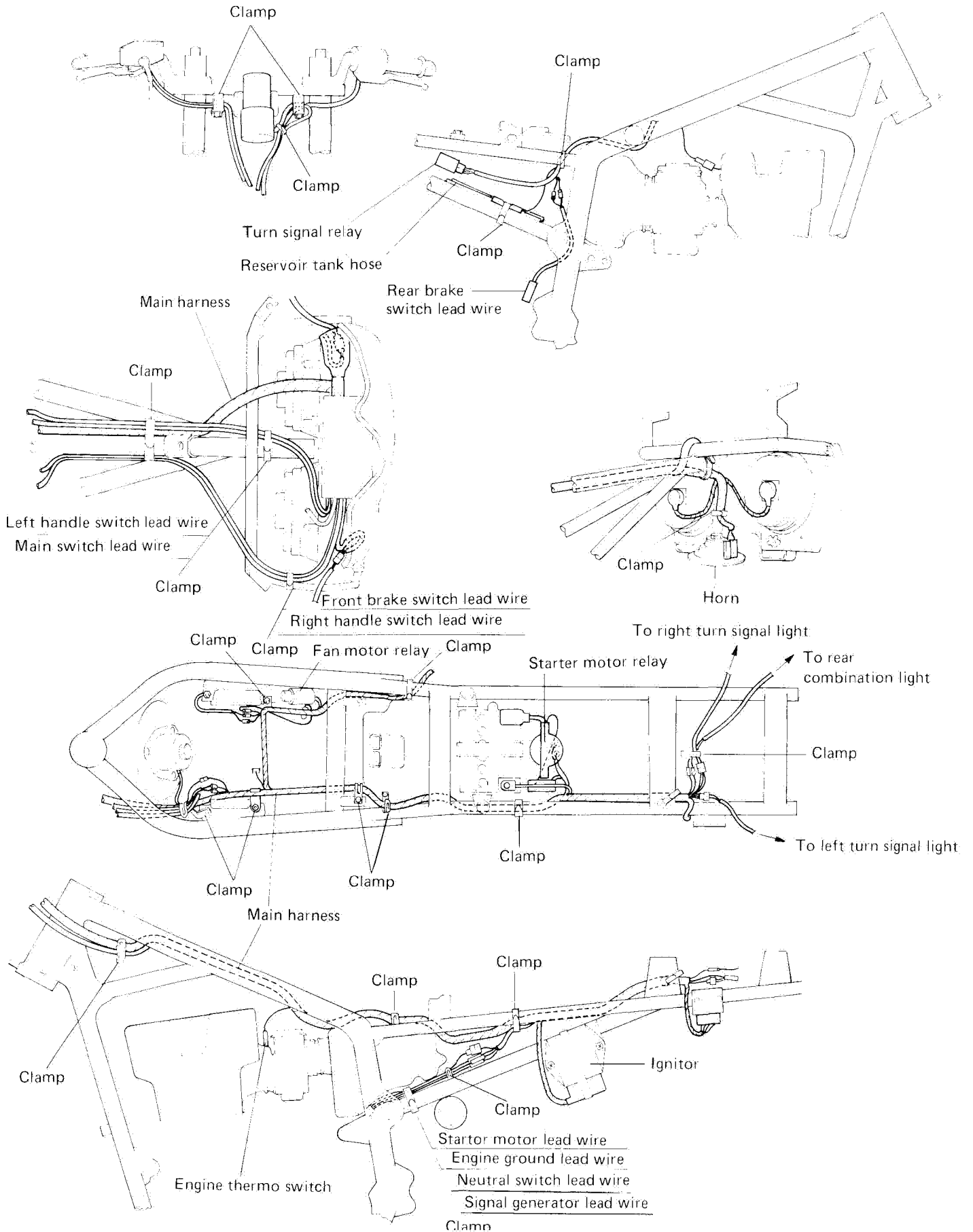



# SIGNAL GENERATOR ROUTING

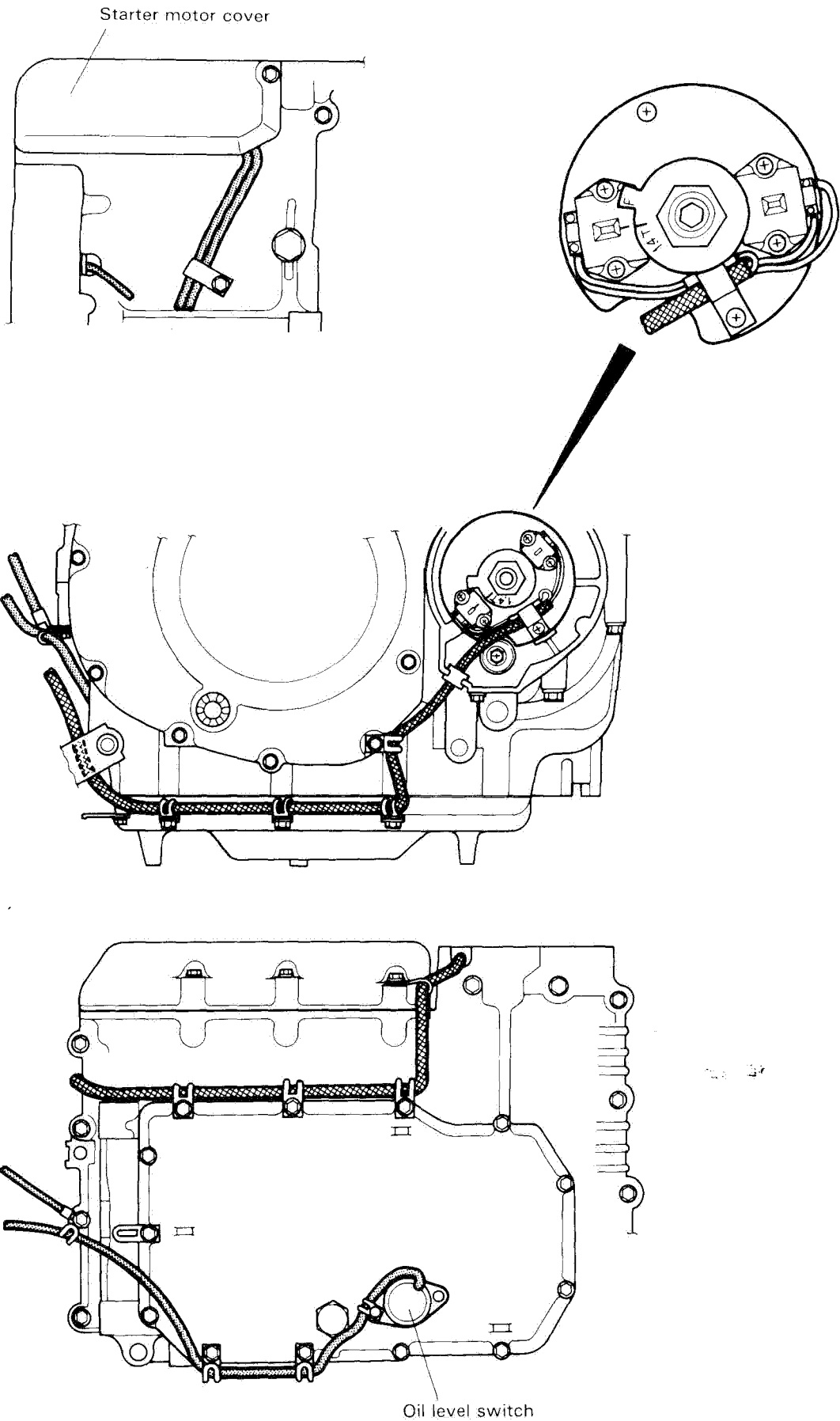

**HIGH TENSION CORD ROUTING**

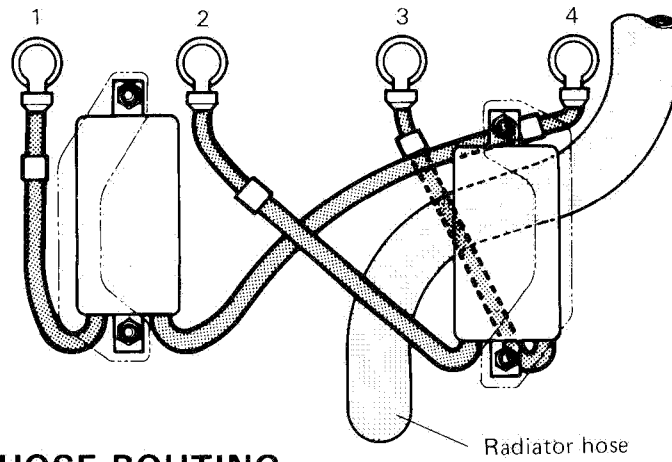
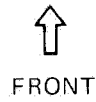

**REAR SUSPENSION HOSE ROUTING**

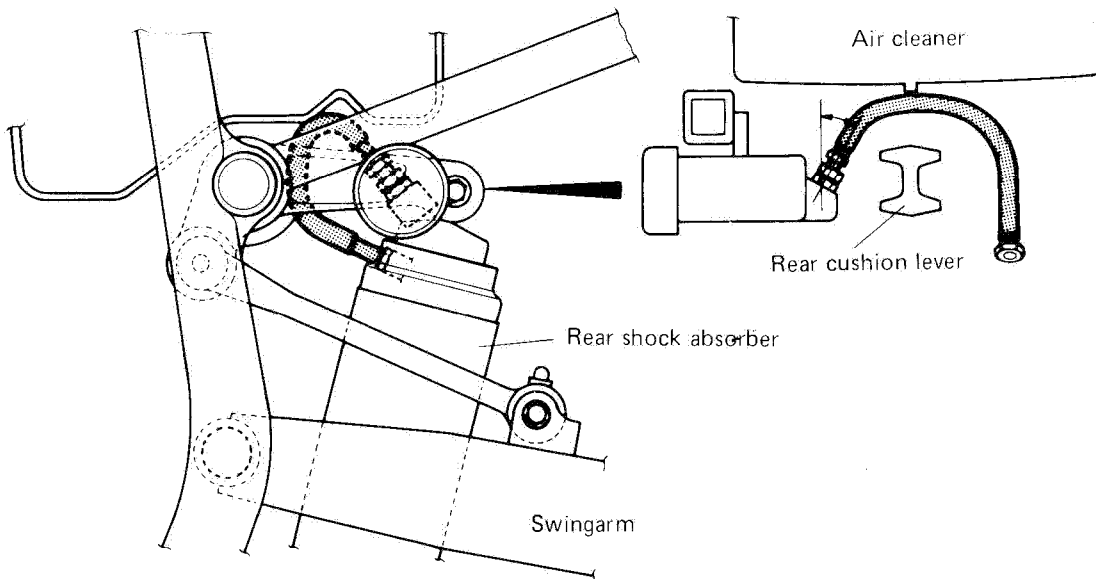
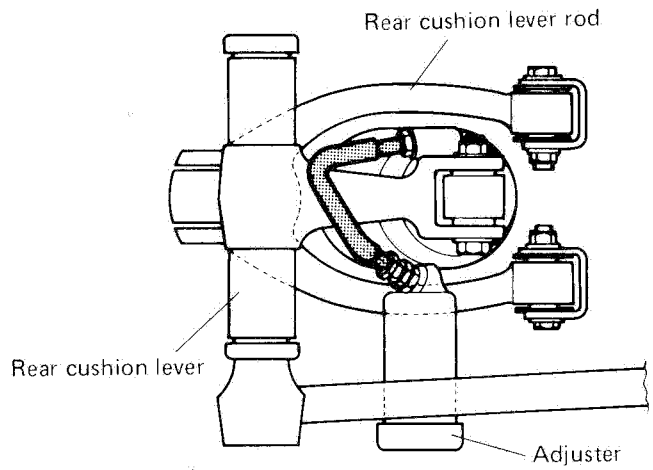

### FUEL HOSE ROUTING

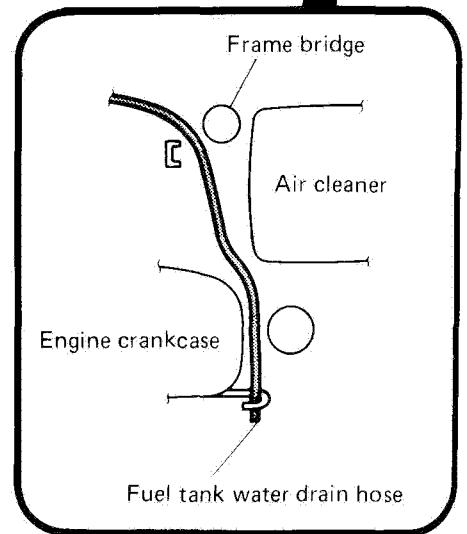
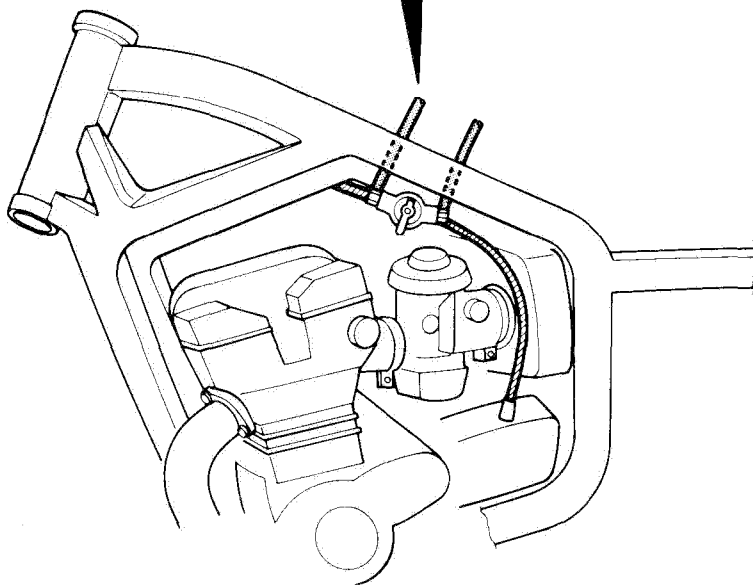
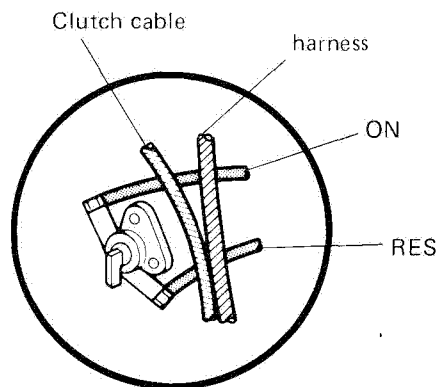
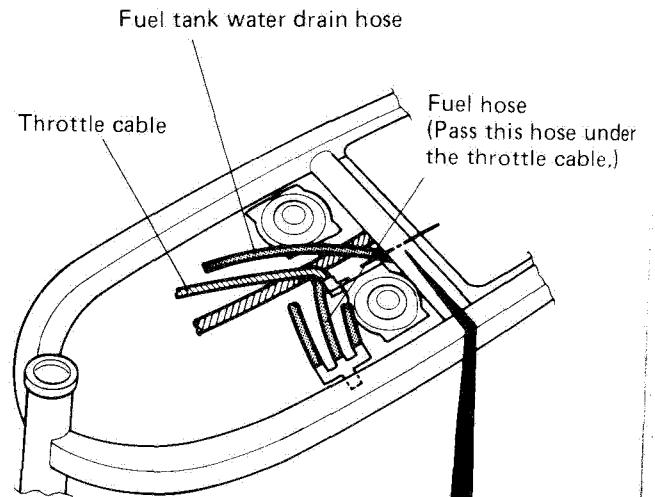
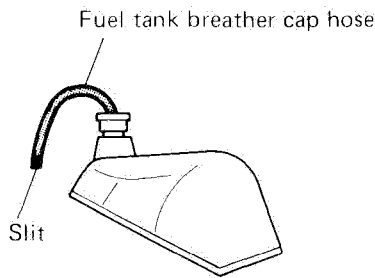
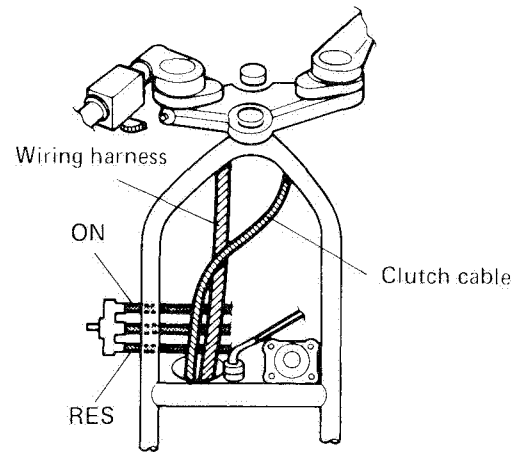
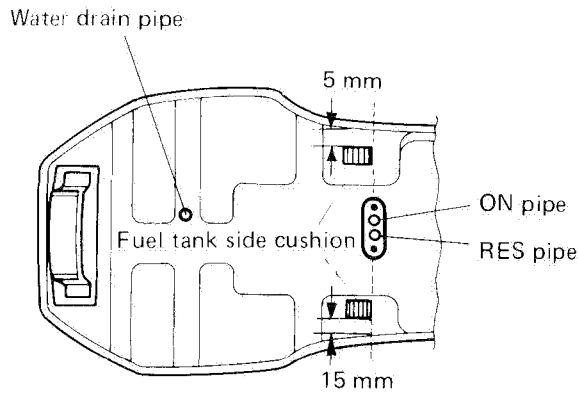

### CARBURETOR HOSE ROUTING

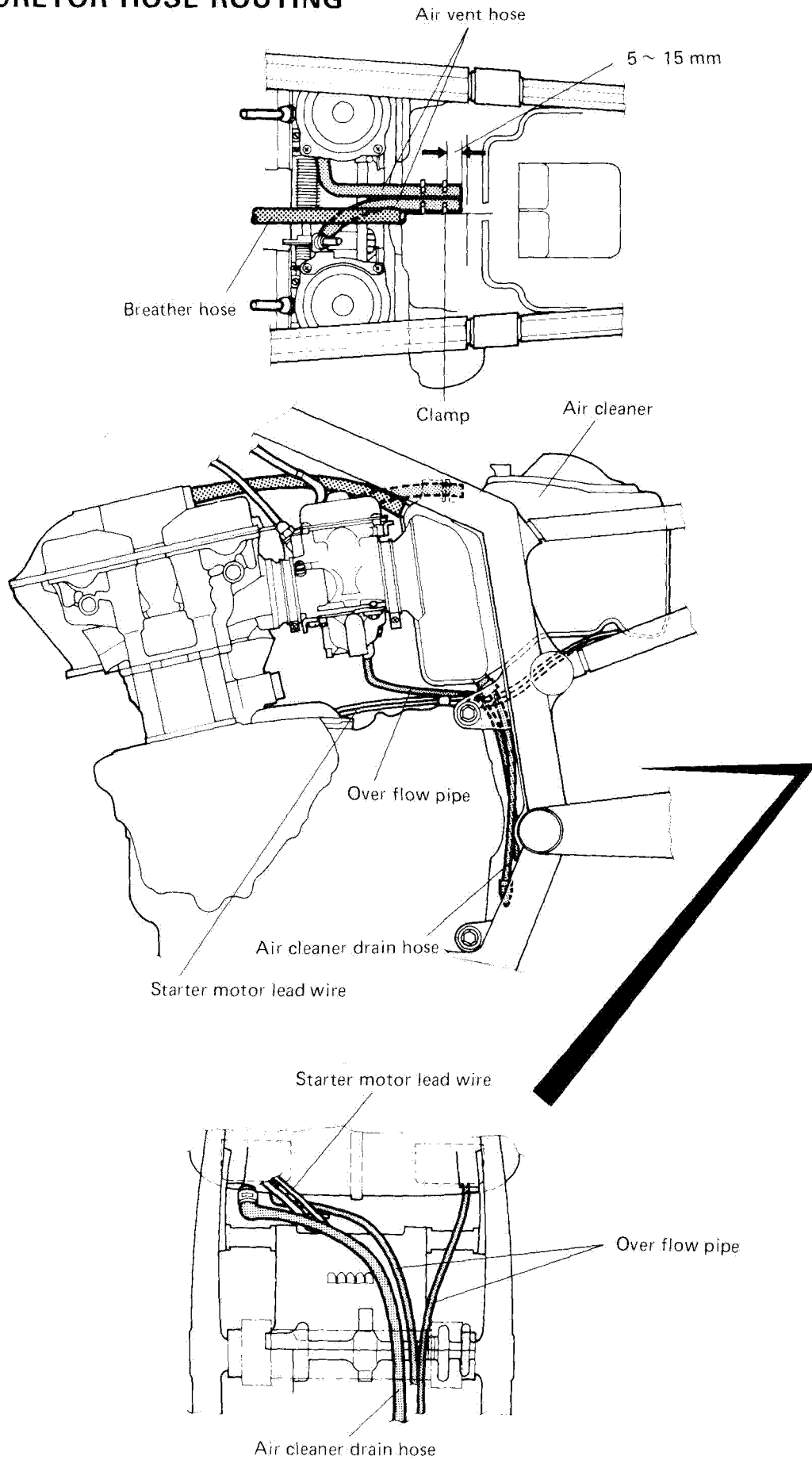

**SPECIAL TOOLS**

Item	Part No.	Part Name
1	09900-00302-015	8 mm T-type box wrench
	09900-06711	7 mm T-type box wrench
2	09900-00401	L-type hexagon wrench set (3, 4, 5, 6, 8, 10 mm)
3	09900-06104	Snap ring pliers (Opening type)
4	09900-06105	Snap ring pliers (Closing type)
5	09900-06107	Snap ring pliers (Opening type)
6	09900-06108	Snap ring pliers (Closing type)
7	09900-09003	Impact driver set
8	09900-20102	Vernier calipers (200 mm)
9	09900-20205	Micrometer (0 – 25 mm)
	-20202	" (25 – 50 mm)
	-20203	" (50 – 75 mm)
10	09900-20508	Cylinder gauge set
11	09900-20605	Dial calipers (10 – 34 mm)
12	09900-20606	Dial gauge (1/100 mm)
13	09900-20701	Magnetic stand
14	09900-20803	Thickness gauge
	-20804	"
	-20806	" (For checking valve clearance)
15	09900-20805	Tire depth gauge
16	09900-21101	Torque wrench (0.5 – 4.5 kg-m)
	-21102	" (0 – 1.2 kg-m)
	-21103	" (1.0 – 9.0 kg-m)
17	09900-21303	V-block set
18	09900-22301	Plastigauge
19	09900-22401	Small bore gauge (10 – 18 mm)
	-22403	" (18 – 35 mm)
20	09900-25002	Pocket tester
21	09900-27311	Timing light
22	09900-28106	Electrotester
23	09900-28403	Hydrometer
24	09910-10710	Stud bolt installer (8 mm)
25	09910-20116	Conrod stopper
26	09910-34510	Piston pin puller
27	09911-60611	Universal clamp wrench
28	09911-73730	"T" type hexagon wrench (5 mm)
	09914-25811	"T" type hexagon wrench (6 mm)
29	09912-34510	Cylinder disassembling tool
30	09913-13121	Carburetor balancer gauge set
	-13140	Adapter
31	09913-14541	Fuel level gauge set
32	09913-14911	Throttle valve adjust wrench
33	09913-50121	Oil seal remover
34	09915-64510	Compression gauge
35	09915-63310	Adapter
36	09915-74510	Oil pressure gauge
	-77330	Meter (0 – 10 kg/cm <sup>2</sup> )

Item	Part No.	Part Name
37	09915-94511	Carburetor balancer adapter
38	09916-14510	Valve lifter
	-14910	Attachment
39	09916-21110	Valve seat cutter set
40	09916-20410	Valve seat cutter head (15°) (N-134)
	-24460	Valve seat cutter head (15°) (N-130)
	-24470	Valve seat cutter head (45°) (N-131)
41	09916-34541	Ⓐ Reamer handle
	-34570	Ⓑ Valve guide reamer (5.0 mm)
	-34580	Valve guide hole reamer (10.8 mm)
42	09916-44310	Valve guide remover
43	09916-44920	Valve guide installer attachment
44	09916-74520	Ⓐ Piston ring holder body
	-74530	Ⓑ Band (Bore: 55 – 65 mm)
45	09916-84510	Tweezers
46	09917-14910	Tappet adjust driver
47	09920-53710	Clutch sleeve hub holder
48	09921-20210	Bearing remover
49	09923-74510	Bearing remover
50	09924-84510	Bearing installer set
51	09930-14511	Cylinder head nut and spark plug wrench set
		Ⓐ 09914-24510 "T" handle
		Ⓑ 09911-74510 Long socket (14 mm)
		Ⓒ 09911-74520 " " (12 mm)
		Ⓓ 09930-14530 Universal joint
		Ⓔ 09930-14520 Spark plug wrench (21 mm)
52	09930-30102	Rotor remover sliding shaft
53	09930-30180	Attachment "E"
54	09930-44911	Rotor holder
55	09940-14911	Steering stem nut wrench
56	09940-34520	Front fork assembling "T" handle
	-34570	Attachment "E"
57	09940-50112	Front fork oil seal installer
58	09941-50110	Bearing remover
59	09941-34513	Steering outer race installer
60	09941-44910	Swing arm bearing installer
61	09941-54911	Bearing outer race remover
62	09941-74910	Steering bearing installer
63	09941-84510	Bearing inner race remover
64	09941-94510	Rim protector
65	09943-74111	Front fork oil level gauge
66	09950-64510	Tire changer
67	96200-41330	Tire pressure gauge

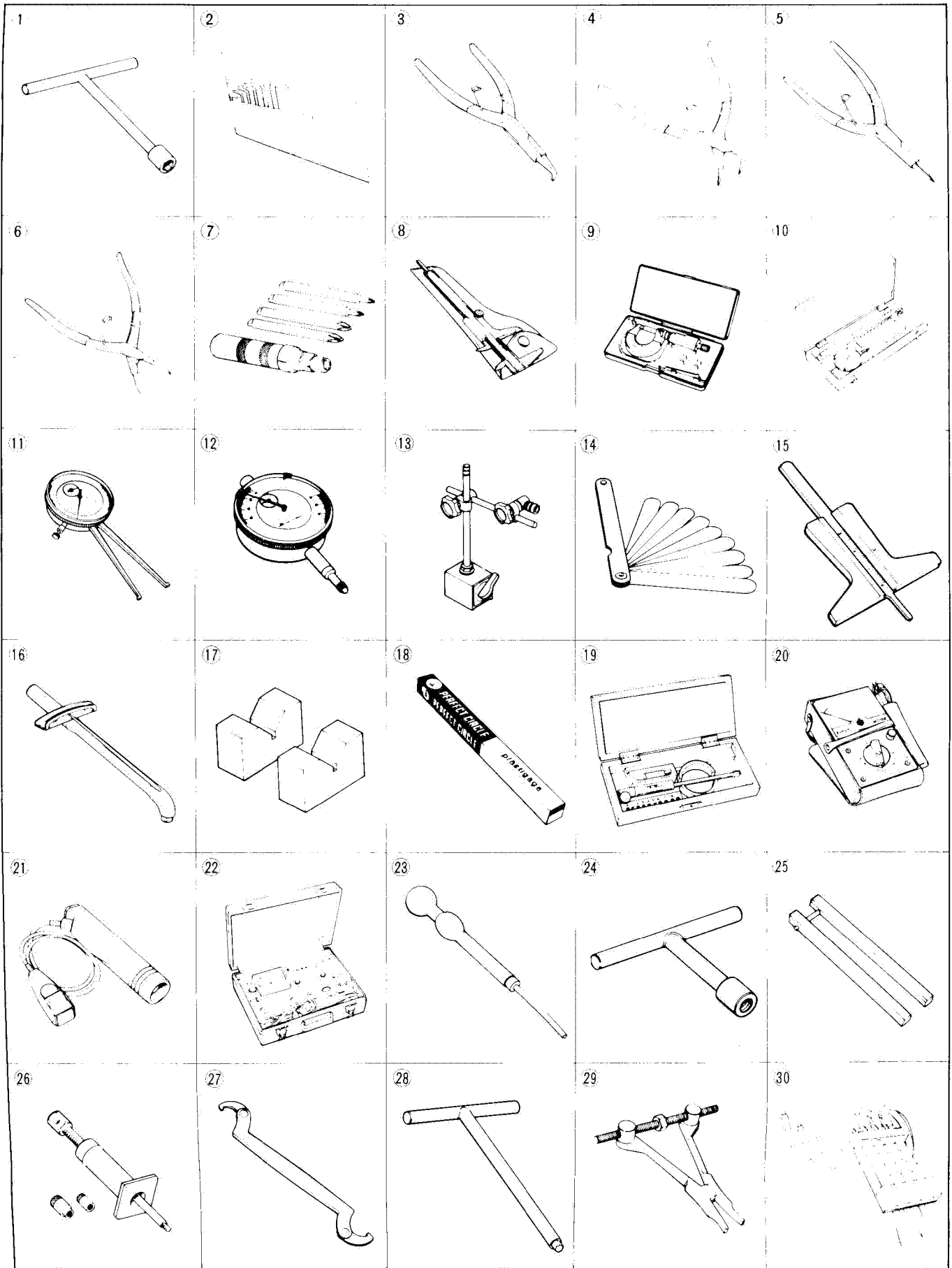

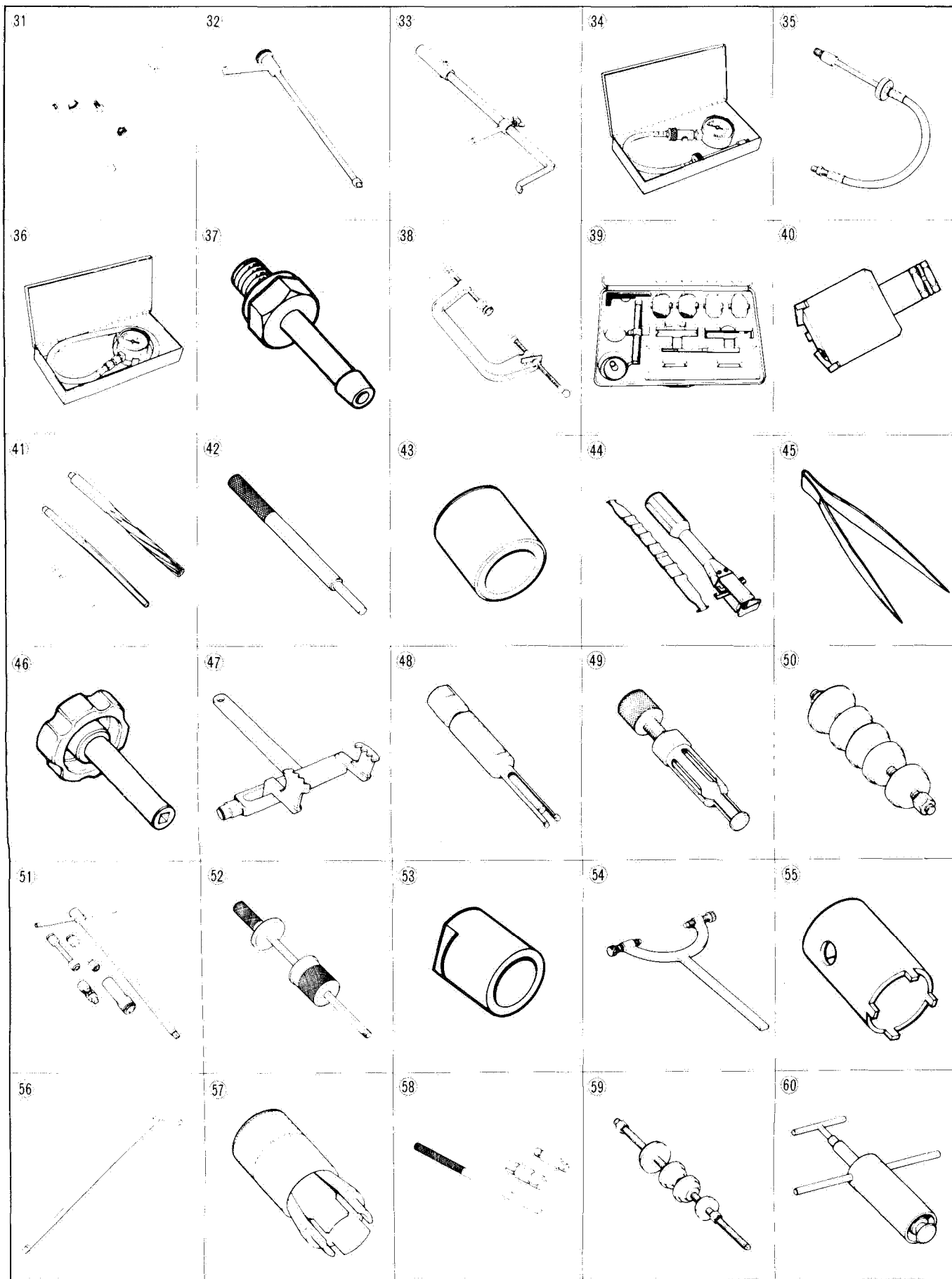



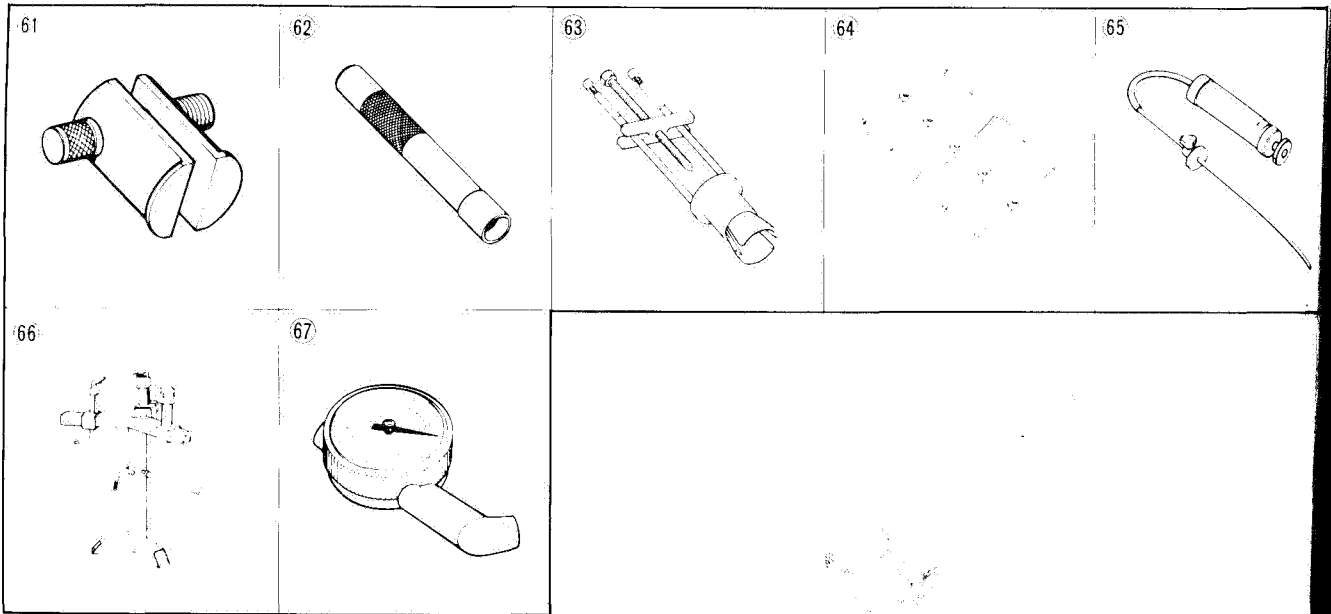

**TIGHTENING TORQUE****ENGINE**

ITEM	N·m	kg·m
Cylinder head cover bolt	11 – 13	1.1 – 1.3
Cylinder head bolt	8 – 12	0.8 – 1.2
Cylinder head nut	25 – 29	2.5 – 2.9
Cam shaft holder bolt	10 – 14	1.0 – 1.4
Cam shaft sprocket bolt	24 – 26	2.4 – 2.6
Cam chain tensioner adjuster bolt	6 – 8	0.6 – 0.8
Cam shaft oil pipe bolt	4 – 7	0.4 – 0.7
Oil pan bolt	8 – 13	0.8 – 1.3
Oil level switch bolt	8 – 12	0.8 – 1.2
Oil pressure regulator	25 – 30	2.5 – 3.0
Oil pump bolt	8 – 12	0.8 – 1.2
Oil drain plug	20 – 25	2.0 – 2.5
Oil filter cap nut	5 – 7	0.5 – 0.7
Oil strainer bolt	4 – 7	0.4 – 0.7
Oil strainer protector bolt	5 – 8	0.5 – 0.8
Clutch sleeve hub nut	50 – 70	5.0 – 7.0
Clutch spring bolt	11 – 13	1.1 – 1.3
Push rod oil seal retainer bolt	8 – 12	0.8 – 1.2
Valve rocker arm shaft bolt	25 – 30	2.5 – 3.0
Water pump drain plug	10	1.0
Water pump impeller bolt	7 – 9	0.7 – 0.9
Water pipe flange nut	4 – 7	0.4 – 0.7
Water pump case screw	5	0.5
Water pipe connection bolt	4 – 7	0.4 – 0.7
Generator rotor bolt	140 – 160	14.0 – 16.0
Conrod nut	23 – 27	2.3 – 2.7
Single generator bolt	25 – 35	2.5 – 3.5
Starter clutch bolt	23 – 28	2.3 – 2.8
Starter motor bolt	8 – 13	0.8 – 1.3
Thermo switch	12 – 15	1.2 – 1.5
Thermostat housing bolt	10 – 15	1.0 – 1.5
Radiator outlet drain bolt	12 – 16	1.2 – 1.6
Radiator mounting nut	7 – 9	0.7 – 0.9
Radiator cushion bolt	10 – 13	1.0 – 1.3
Radiator air bleeder plug	3	0.3
Reserver tank cap	4	0.4

ITEM		N·m	kg·m
Pressure inspection plug		25 – 30	2.5 – 3.0
Engine mounting bolt	L: 270	60 – 72	6.0 – 7.2
	L: 170	60 – 72	6.0 – 7.2
	L: 165	60 – 72	6.0 – 7.2
Exhaust pipe bolt		9 – 12	0.9 – 1.2
Muffler mounting bolt		40 – 60	4.0 – 6.0
Crankcase bolt	6 mm	8 – 12	0.8 – 1.2
	8 mm	20 – 24	2.0 – 2.4
Cylinder head cover cap bolt		8 – 13	0.8 – 1.3
Spark plug		10 – 15	1.0 – 1.5
Oil hose union bolt	8 mm	8 – 12	0.8 – 1.2
	10 mm	20 – 24	2.0 – 2.4

**CHASSIS**

ITEM	N·m	kg·m
Front axle nut	36 – 52	3.6 – 5.2
Front axle pinch bolt	15 – 25	1.5 – 2.5
Front fork cap bolt	15 – 30	1.5 – 3.0
Front fork upper clamp bolt	15 – 25	1.5 – 2.5
Front fork lower clamp bolt	15 – 25	1.5 – 2.5
Front fork damper rod bolt	20 – 26	2.0 – 2.6
Steering stem head bolt	20 – 30	2.0 – 3.0
Steering stem clamp bolt	15 – 25	1.5 – 2.5
Steering stem nut	40 – 50	4.0 – 5.0
Handlebar holder bolt	50 – 60	5.0 – 6.0
Handlebar holder nut	20 – 30	2.0 – 3.0
Front brake master cylinder bolt	5 – 8	0.5 – 0.8
Front brake hose joint bolt	20 – 25	2.0 – 2.5
Caliper air bleeder (Front & Rear)	6 – 9	0.6 – 0.9
Brake hose union bolt (cylinder, caliper side)	20 – 25	2.0 – 2.5
Front brake caliper mounting bolt	15 – 25	1.5 – 2.5
Front brake caliper housing bolt	30 – 36	3.0 – 3.6
Modulator plunger bolt	4 – 5	0.4 – 0.5
Modulator valve bolt	6 – 8	0.6 – 0.8
Modulator air bleeder	6 – 9	0.6 – 0.9
Front brake lever nut	8 – 12	0.8 – 1.2
Brake pedal bolt	6 – 10	0.6 – 1.0
Rear torque link nut (Front)	10 – 15	1.0 – 1.5
Rear torque link nut (Rear)	20 – 30	2.0 – 3.0
Rear swing arm pivot nut	50 – 80	5.0 – 8.0
Rear brake caliper mounting bolt	15 – 25	1.5 – 2.5
Rear shock absorber fitting bolt (Upper & Lower)	40 – 60	4.0 – 6.0
Rear sprocket nut	48 – 72	4.8 – 7.2
Disc plate bolt (Front and Rear)	15 – 25	1.5 – 2.5
Rear brake caliper housing bolt	30 – 36	3.0 – 3.6
Rear cushion lever nut (Center)	40 – 60	4.0 – 6.0
Rear cushion lever nut (Front)	40 – 60	4.0 – 6.0
Rear cushion rod nut	18 – 28	1.8 – 2.8
Rear footrest bolt	8 – 12	0.8 – 1.2
Rear axle nut	50 – 80	5.0 – 8.0
Rear brake master cylinder mounting bolt	15 – 25	1.5 – 2.5

## TIGHTENING TORQUE CHART

For other bolts and nuts not listed above, refer to this chart:

Tightening torque

Bolt Diameter (mm)	Conventional or "4" marked bolt		"7" marked bolt	
	N·m	kg·m	N·m	kg·m
4	1 – 2	0.1 – 0.2	1.5 – 3	0.15 – 0.3
5	2 – 4	0.2 – 0.4	3 – 6	0.3 – 0.6
6	4 – 7	0.4 – 0.7	8 – 12	0.8 – 1.2
8	10 – 16	1.0 – 1.6	18 – 28	1.8 – 2.8
10	22 – 35	2.2 – 3.5	40 – 60	4.0 – 6.0
12	35 – 55	3.5 – 5.5	70 – 100	7.0 – 10.0
14	50 – 80	5.0 – 8.0	110 – 160	11.0 – 16.0
16	80 – 130	8.0 – 13.0	170 – 250	17.0 – 25.0
18	130 – 190	13.0 – 19.0	200 – 280	20.0 – 28.0

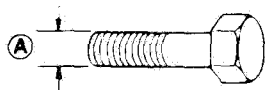

Conventional Bolt

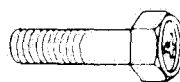

"4" Marked Bolt



"7" Marked Bolt

**SERVICE DATA****VALVE + GUIDE**

Unit: mm

ITEM	STANDARD		LIMIT
Valve diam.	IN.	21	—
	EX.	18	—
Valve lift	IN.	7.5	—
	EX.	6.2	—
Valve clearance (when cold)	IN. & EX.	4 THCV 0.13–0.18 6 THCV	—
Valve guide to valve stem clearance	IN.	0.025–0.052	0.35
	EX.	0.040–0.067	0.35
Valve guide I.D.	IN. & EX.	5.000–5.012	—
Valve stem O.D.	IN.	4.960–4.975	—
	EX.	4.945–4.960	—
Valve stem runout	IN. & EX.	—	0.05
Valve head thickness	IN. & EX.	—	0.5
Valve stem end length	IN. & EX.	—	2.9
Valve seat width	IN. & EX.	0.9–1.1	—
Valve head radial runout	IN. & EX.	—	0.03
Valve spring free length (INTAKE)	INNER	—	31.6
	OUTER	—	35.2
Valve spring free length (EXHAUST)	INNER	—	31.1
	OUTER	—	35.2
Valve spring tension (IN. & EX.)	INNER	5.0–5.9 kg at length 28 mm	—
	OUTER	8.4–9.8 kg at length 31.5 mm	—

**CAMSHAFT + CYLINDER HEAD**

Unit: mm

ITEM	STANDARD		LIMIT
Cam height	IN.	34.910–34.950	34.61
	EX.	34.140–34.180	33.84
Camshaft journal oil clearance	IN. & EX.	0.032–0.066	0.150
Camshaft journal holder I.D.	IN. & EX.	22.012–22.025	—
Camshaft journal O.D.	IN. & EX.	21.959–21.980	—
Camshaft thrust clearance	IN. & EX.	0.05–0.25	—
Camshaft runout	IN. & EX.	—	0.10
Cam chain 20-pitch length	—		157.8
Cam chain pin (at arrow "3")	19th pin		—
Rocker arm I.D.	IN. & EX.	12.000–12.018	—
Rocker arm shaft O.D.	IN. & EX.	11.973–11.984	—
Cylinder head distortion	—		0.20

**CYLINDER + PISTON + PISTON RING**

Unit: mm

ITEM	STANDARD		LIMIT
Compression pressure	1 100—1 500 kPa,(11—15 kg/cm <sup>2</sup> )		900 kPa, ( 9 kg/cm <sup>2</sup> )
Compression pressure difference	—		200 kPa, ( 2 kg/cm <sup>2</sup> )
Piston to cylinder clearance	0.035—0.045		0.120
Cylinder bore	53.005—53.020		53.100
Piston diam.	52.965—52.980 Measure at 14 from the skirt end.		52.885
Cylinder distortion	—		0.20
Piston ring free end gap	1st	Approx. 6.5	5.2
	2nd	Approx. 6.0	4.8
Piston ring end gap	1st	0.15—0.30	0.70
	2nd	0.15—0.30	0.70
Piston ring to groove clearance	1st	—	0.180
	2nd	—	0.150
Piston ring groove width	1st	0.805—0.830	—
	2nd	1.010—1.030	—
	Oil	2.010—2.030	—
Piston ring thickness	1st	0.770—0.795	—
	2nd	0.970—0.990	—
Piston pin bore	14.002—14.008		14.030
Piston pin O.D.	13.995—14.000		13.980

**CONROD + CRANKSHAFT**

Unit: mm

ITEM	STANDARD		LIMIT
Conrod small end I.D	14.010—14.018		14.040
Conrod big end side clearance	0.10—0.20		0.30
Conrod big end width	16.95—17.00		—
Crank pin width	17.10—17.15		—
Conrod big end oil clearance	0.024—0.048		0.080
Crank pin O.D.	29.976—30.000		—
Crankshaft journal oil clearance	0.020—0.044		0.080
Crankshaft journal O.D.	31.976—32.000		—
Crankshaft thrust bearing thickness	R	2.425—2.450	—
	L	2.350—2.500	—
Crankshaft thrust clearance	0.045—0.100		—
Crankshaft runout	—		0.05

**OIL PUMP**

ITEM	STANDARD	LIMIT
Oil pump reduction ratio	1.921 ( 104/47 × 33/38 )	—
Oil pressure (at 60°C, 140°F)	Above 250 kPa, 2.5 kg/cm <sup>2</sup> Below 550 kPa, 5.5 kg/cm <sup>2</sup> at 3 000 r/min.	—

**CLUTCH**

Unit: mm

ITEM	STANDARD	LIMIT
Clutch cable play	4	—
Clutch release screw	1/4-1/2 turn back	—
Drive plate thickness	2.9—3.1	2.6
Drive plate claw width	11.8—12.0	11.0
Driven plate distortion	—	0.10
Clutch spring free length	—	31.0

**THERMOSTAT + RADIATOR + FAN**

ITEM	STANDARD	LIMIT
Thermostat valve opening temperature	75.0 ± 1.5°C	—
Thermostat valve lift	5.9—6.1 mm at 90°C	—
Radiator cap valve release pressure	1.1 ± 0.15 kg/cm <sup>2</sup> (110 ± 15 kPa)	—
Electric fan thermo-switch	ON	Approx. 110°C
	OFF	Approx. 103°C
Electric fan relay resistance	Approx. 70 Ω	—
Thermo-gauge resistance	28.3 Ω at 100°C	—

**TRANSMISSION + DRIVE CHAIN**

Unit: mm Except ratio

ITEM	STANDARD	LIMIT
Primary reduction ratio	2.212 ( 104/47 )	—
Final reduction ratio	3.066 ( 46/15 )	—
Gear ratios	Low	3.166 ( 38/12 )
	2nd	2.125 ( 34/16 )
	3rd	1.631 ( 31/19 )
	4th	1.333 ( 28/21 )
	5th	1.173 ( 27/23 )
	Top	1.083 ( 26/24 )
Shift fork to groove clearance	0.10—0.30	0.50
Shift fork groove width	5.50—5.60	—
Shift fork thickness	5.30—5.40	—
Drive chain	Type	DAIDO: DID 525V TAKASAGO: RK525SM
	Links	114 links
	20-pitch length	—
Drive chain slack	20—30	319.4

**CARBURETOR**

ITEM	SPECIFICATION
Carburetor type	AISAN AS27VW
Bore size	27 mm
I.D. No.	04A10



ITEM	SPECIFICATION
Idle r/min.	1 300 ± 100 r/min.
Fuel level	9.0 ± 0.5 mm
Float height	20.5 ± 1.0 mm
Main jet (M.J.)	#94
Main air jet (M.A.J.)	1.2 mm
Jet needle (J.N.)	5B10-3rd
Needle jet (N.J.)	2.60 mm
Throttle valve (Th.V.)	11.0
Pilot jet (P.J.)	#34
By-pass (B.P.)	0.8, 0.8, 0.8 mm
Pilot outlet (P.O.)	0.8 mm
Valve seat (V.S.)	2.5 mm
Starter jet (G.S.)	GS <sub>1</sub> #60, GS <sub>2</sub> #54
Pilot screw (P.S.)	PRE-SET (2 turns back )
Pilot air jet (P.A.J.)	1.35 mm
Throttle cable play	0.5–1.0 mm
Choke cable play	0.5–1.0 mm

**ELECTRICAL**

Unit: mm

ITEM	SPECIFICATION	NOTE	
Ignition timing	15° B.T.D.C. Below 1 650 ± 100 r/min. and 35° B.T.D.C. Above 3 500 ± 100 r/min.		
Firing order	1 · 2 · 4 · 3		
Spark plug	Type	N.D.: U24FS-U NGK: C8HA	
	Gap	0.6–0.7	
Spark performance	Over 8 at 1 atm.		
Signal coil resistance	250–500 Ω		
Ignition coil resistance	Primary	3–7 Ω	⊕ tap – ⊖ tap
	Secondary	30–60 kΩ	Plug cap – Plug cap
Generator no-load voltage	More than 80 V (AC) at 5 000 r/min.		
Regulated voltage	13.5–15.5 V at 5 000 r/min.		
Starter motor brush length	Limit: 9	N.D.	
Commutator under-cut	Limit: 0.2		
Starter relay resistance	3–7 Ω		
Thermostat resistance	104 Ω at 60 ± 10°C		
	27.4 Ω at 100 ± 2°C		
Battery	Type designation	YB10L-B2	
	Capacity	12V39.6kC(11Ah)/10HR	
	Standard electrolyte S.G.	1.28 at 20°C (68°F)	
Fuse size	20 A		

**WATTAGE**

Unit: W

ITEM		SPECIFICATION
Headlight	HI	35 × 2
	LO	35 × 2
Tail/Brake light		8/23
Turn signal light		23
Speedometer light		3.4 × 2
Tachometer light		3 × 2
Water temperature light		1.7
Oil level indicator light		3.4
Turn signal indicator light		3.4
High beam indicator light		1.7
Neutral indicator light		3.4
Licence light		8

**BRAKE + WHEEL**

Unit: mm

ITEM	STANDARD		LIMIT
Rear brake pedal height	50		—
Brake disc thickness	Front	4.5 ± 0.2	4.0
	Rear	6.0 ± 0.2	5.3
Brake disc runout	—		0.30
Master cylinder bore	Front	14.000–14.043	—
	Rear	12.700–12.743	—
Master cylinder piston diam.	Front	13.957–13.984	—
	Rear	12.657–12.684	—
Brake caliper cylinder bore	Front	27.000–27.076	—
	Rear	38.180–38.256	—
Brake caliper piston diam.	Front	26.920–26.970	—
	Rear	38.098–38.148	—
Wheel rim runout	Axial	—	2.0
	Radial	—	2.0
Wheel axle runout	Front	—	0.25
	Rear	—	0.25
Tire size	Front	100/90-16 54H	—
	Rear	110/90-18 61H	—
Tire tread depth	Front	—	1.6
	Rear	—	2.0

**SUSPENSION**

Unit: mm

ITEM	STANDARD	LIMIT	NOTE
Front fork stroke	130	—	
Front fork spring free length	—	421	
Front fork oil level	100	—	
Rear wheel travel	124	—	
Swingarm pivot shaft runout	—	0.3	

**TIRE PRESSURE**

COLD INFLATION TIRE PRESSURE	NORMAL RIDING			
	SOLO RIDING		DUAL RIDING	
	kPa	kg/cm <sup>2</sup>	kPa	kg/cm <sup>2</sup>
FRONT	200	2.00	200	2.00
REAR	225	2.25	250	2.50

**FUEL + OIL + COOLANT**

ITEM	SPECIFICATION	NOTE
Fuel type	Gasoline used should be graded 85-95 octane or higher. An unleaded or low-lead type gasoline is recommended.	
Fuel tank including reserve	18.0 L	
reserve	3.5 L	
Engine oil type	SAE 10W/40, API SE or SF	
Engine oil capacity	Change	2 600 ml
	Filter change	3 000 ml
	Overhaul	3 300 ml
Front fork oil type	Fork oil #15	
Front fork oil capacity (each leg)	397 ml	
Coolant	2 185 ml	
Brake fluid type	DOT3, DOT4 or SAEJ1703	

Prepared by

**SUZUKI MOTOR CORPORATION**

Motorcycle Technical Service Department  
Motorcycle Service Division

May, 1985

Manual No.: 99500-33000-01E (英)

Printed in Japan

**SUZUKI MOTOR CORPORATION**

Printed in Japan

SUZUKI

**SUZUKI**  
**パワーストロン**

GSX400RSH

**SUZUKI**

**GSX400RSH**

(GK71F)

SUPER ENDURANCE

**GSXR400**

1987-5